

COMMERCIAL
MODEL: B50 BOOSTER

CATALOG NO. 9400.29
Effective: 08-03-12
Replaces: NEW

RAYPAK ILLUSTRATED PARTS LIST

MODEL SIZE: B50A

MODEL TYPE: B (BOOSTER)

DATES OF MANUFACTURE: 1998 THROUGH 2000

THE PARTS LISTED ARE FOR STANDARD EQUIPMENT FOR THIS MODEL TYPE. RAYPAK RESERVES THE RIGHT TO SUBSTITUTE, DELETE OR CHANGE ANY PART WITHOUT NOTIFICATION. THE ADDITION OF OPTIONS MAY ALSO CHANGE SOME OF THE PARTS. ORDER REPLACEMENT PARTS FROM ACTUAL HEATER COMPONENTS.



FOR DETAILED INSTRUCTIONS, SEE "HOW TO USE YOUR RAYPAK ILLUSTRATED PARTS LIST",
CATALOG NO. 9001.10



Raypak, Inc., 2151 Eastman Avenue, Oxnard, CA 93030
(805) 278-5300 Fax (800) 872-9725
Litho In U.S.A.

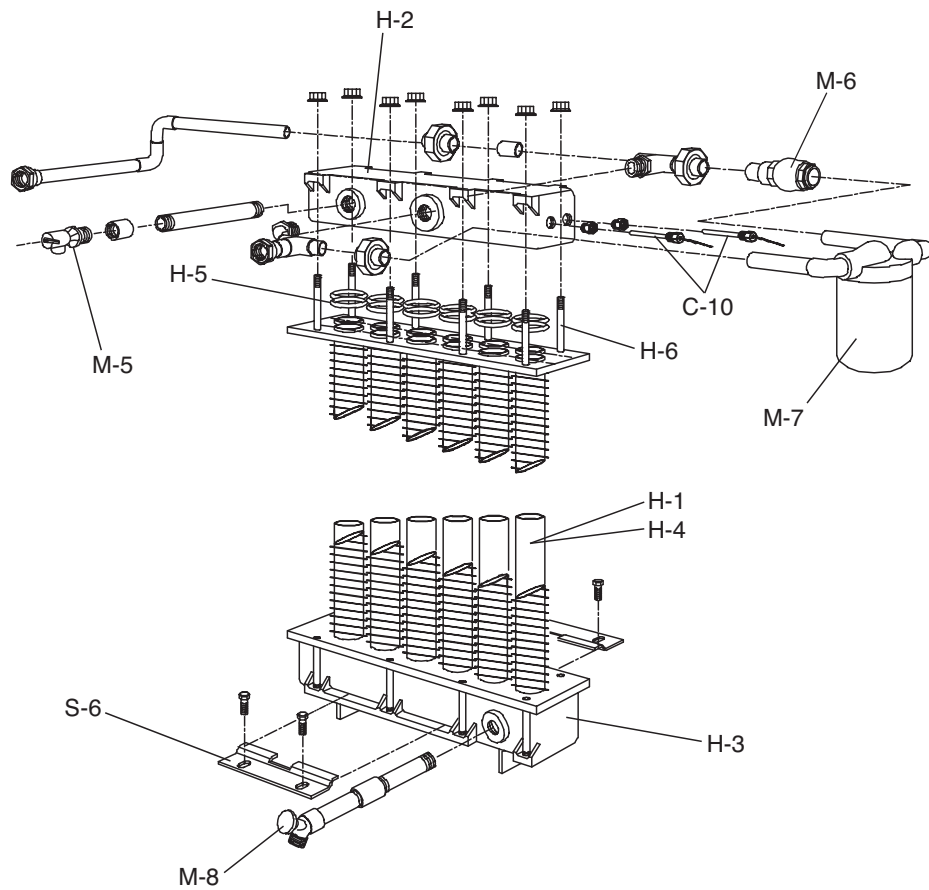
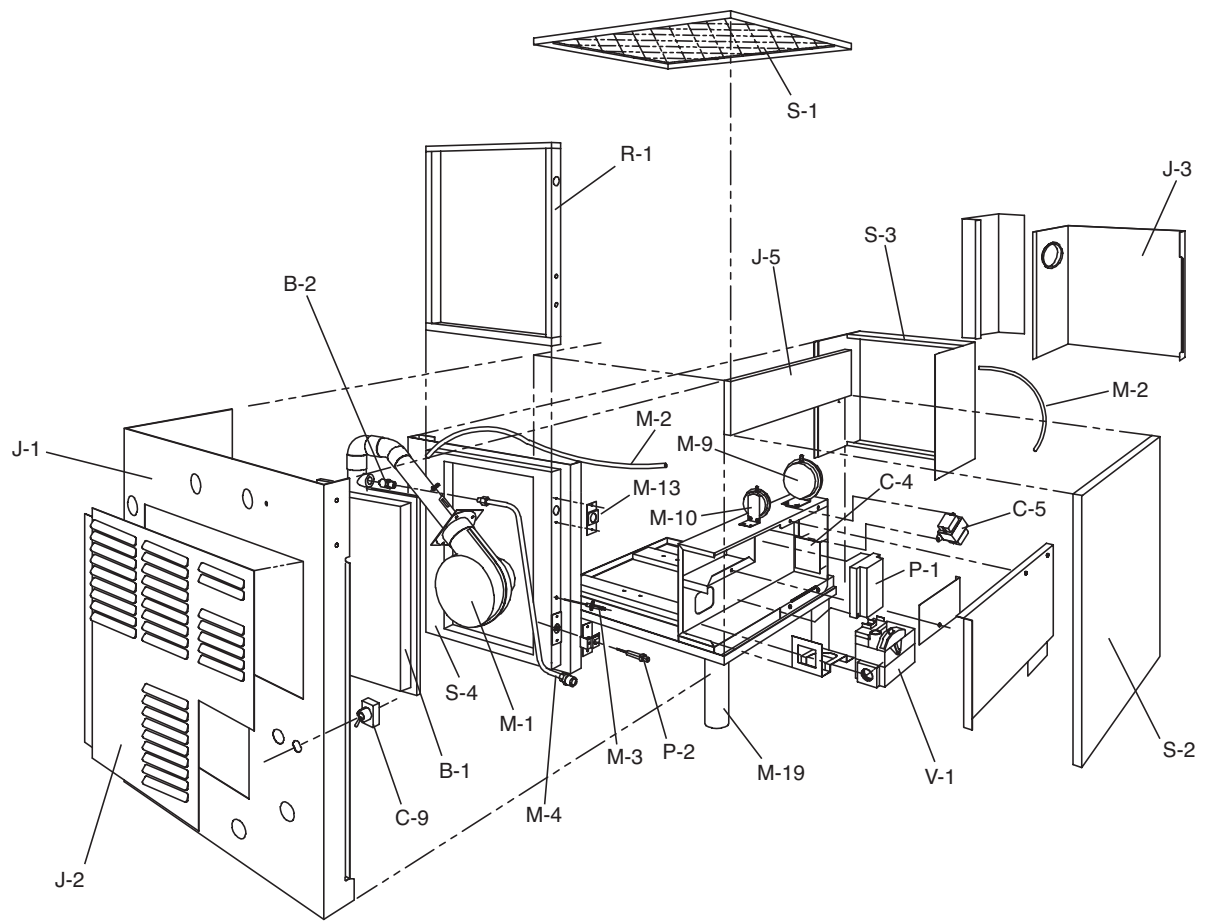

CALL OUT	DESCRIPTION	PART NO.
B	BURNER TRAY	
B 1	BURNER	006206F
B 2	**ORIFICE NAT. SEA LEVEL	351202
	**ORIFICE PRO. SEA LEVEL	351203
C	CONTROLS	
C 2	CONTROL BOX	N/A
C 4	OPERATING LIMIT CONTROL	006530F
C 5	TRANSFORMER 24/120,50 VA	006533F
C 9	SWITCH ON/OFF	006531F
C 10	WATER TEMPERATURE SENSOR PROBE	006532F
H	HEAT EXCHANGER	
H 1	HEAT EXCHANGER COMPLETE (INCLUDES M6, M7)	006233F
H 2	INLET/OUTLET HEADER	006234F
H 3	RETURN HEADER	006235F
H 4	TUBE BUNDLE	006236F
H 5	O'RING GASKET	006237F
H 6	STUD KIT	006238F
J	JACKET	
J 1	JACKET PANEL LEFT	006212F
J 2	ACCESS PANEL	006213F
J 3	JACKET PANEL RIGHT	006214F
J 5	JACKET PANEL UPPER FRONT (STAINLESS STEEL)	006216F
M	MISCELLANEOUS	
M 1	BLOWER - COMBUSTION AIR	006218F
M 2	AIR PRESSURE SWITCH TUBING	006231F
M 3	FLAME SENSOR	006535F
M 4	GAS TUBE	006219F
M 5	PRESSURE RELIEF VALVE	006534F
M 6	BALL CHECK VALVE	006240F
M 7	PUMP	006241F
M 18	PUMP CARTRIDGE	951284F
M 8	DRAIN VALVE	006536F
M 9	VENT PRESSURE SWITCH (N. C.)	006538F
M 10	COMBUSTION AIR PRESSURE SWITCH (N. O.)	006537F
M 13	INSPECTION WINDOW	005193F
M 14	WIRE HARNESS 120V	N/A
M 15	WIRE HARNESS 24V	N/A
M 16	SILICONE RUBBER SEALANT (10 oz)	005755F
M 17	WATER PRESSURE REGULATOR	006539F
M 19	LEG	006217F
P	PILOT	
P 1	IGNITION CONTROL MODULE	006540F
P 2	HOT SURFACE IGNITOR	005329F
R	REFRACTORY	
R 1	REFRACTORY KIT	006220F
S	SHEET METAL	
S 1	JACKET TOP (STAINLESS STEEL)	006224F
S 2	DOOR (STAINLESS STEEL)	006225F
S 3	FLUE COLLECTOR ASSEMBLY	006226F
S 4	COMBUSTION BOX	006227F
S 6	RETAINER HEAT EXCHANGER	006242F
V	GAS VALVE	
V 1	GAS VALVE, NAT.	006541F
	GAS VALVE, PRO.	N/A
V 3	GAS VALVE MANUAL SHUT OFF (NOT SHOWN)	006543F

** FOR ALTITUDE ABOVE 4500 FEET ABOVE SEA LEVEL, CONSULT FACTORY.



Registered Quality Management System

www.raypak.com