

# Table Top Water Heaters



The Ruud Table Top water heater is a good choice for kitchen installations or other work areas that require additional counter space

### Table Top Features

- Baked enamel counter top is acid and heat resistant
- Four inch high backsplash protects interior wall from spills and stains
- Recessed base provides comfortable standing area while working
- Channel at rear accommodates piping and permits water heater to fit snugly against back wall
- More hot water at a low operating cost

### Efficiency

- .81 UEF
- Well insulated for reduced standby heat loss

### Performance

- FHR: 50 gallons
- Recovery: 21 GPH at a 90° F rise

### Capacity & Dimensions

- 40 Gallon model: 24 inch diameter, 25 inch depth and 36 inches high

### Easy Installation & Service

- Table top surface is easily removed for access to cold and hot water outlets at top of tank, electrical connections and anode rod replacement

### Longer Life

- Patented magnesium anode rod with resistor protects the tank from rust

### Plus...

- Durable direct immersion resistored heating element
- Full-flow, brass drain valve
- Temperature and pressure relief valve
- Standard replacement parts

### Warranty

- 6-Year limited tank and parts warranty\*

\*See Residential Warranty Certificate for complete information

Units meet or exceed ANSI requirements and have been tested according to D.O.E. procedures. Units meet or exceed the energy efficiency requirements of NAECA, ASHRAE standard 90, ICC Code and all state energy efficiency performance criteria.



**Table Top Water Heater**  
Large Counter Surface  
40-Gallon Capacity  
240 Volt AC/Single Phase  
Electric

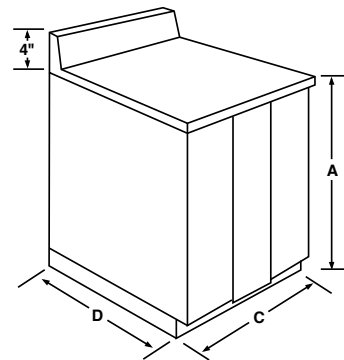
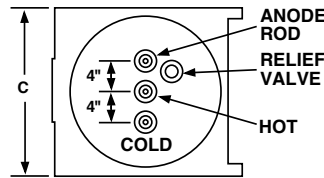

DESCRIPTION			FEATURES		ROUGHING IN DIMENSIONS (SHOWN IN INCHES)					ENERGY INFO.
NOMINAL GALLON CAPACITY	RATED GALLON CAPACITY	MODEL NUMBER	UEF FIRST HOUR RATING G.P.H.	RECOVERY IN G.P.H 90° F RISE	HEIGHT A	HEIGHT TO WATER CONN. B	DIAMETER C	DEPTH D	APPROX. SHIP WT. (LBS.)	UNIFORM ENERGY FACTOR (UEF)
40	36	PET40-2	50	21	36	33	24	25	156	0.81

- Uniform Energy Factor and rated gallon capacity based on Department of Energy (DOE) requirements.
- Heaters furnished with standard 240 volt AC, single phase non-simultaneous wiring, and 4500 watt upper and lower heating elements.
- If heating elements of different wattages than those shown are demanded by zone requirements, they must be specifically requested.**
- Special Wiring Options – A limited number of special wiring options are available. Consult factory for price and availability.
- Sold in U.S. only.

In keeping with its policy of continuous progress and product improvement, Ruud reserves the right to make changes without notice.