

INSTALLATION & OPERATING INSTRUCTIONS

Raytherm[®] Commercial Swimming Pool Heater



Models 514-824



WARNING: If these instructions are not followed exactly, a fire or explosion may result causing property damage, personal injury or death.

FOR YOUR SAFETY: Do not store or use gasoline or other flammable vapors and liquids or other combustible materials in the vicinity of this or any other appliance. To do so may result in an explosion or fire.

WHAT TO DO IF YOU SMELL GAS:

- Do not try to light any appliance.
- Do not touch any electrical switch; do not use any phone in your building.
- Immediately call your gas supplier from a neighbor's phone. Follow the gas supplier's instructions.
- If you cannot reach your gas supplier, call the fire department.

Installation and service must be performed by a qualified installer, service agency or the gas supplier.

This manual should be maintained in legible condition and kept adjacent to the heater or in another safe place for future reference.

Raypak[®]
A Rheem[®] Company

Revision 21 reflects the following:

Removed California Proposition 65 warning on page 4.

CONTENTS

WARNINGS	4
Pay Attention to These Terms	4
WATER CHEMISTRY	5
OWNER'S OPERATING INSTRUCTIONS	6
Start-Up Procedures	6
Operating Instructions and Shut-Off Procedures	6
Automatically Lighted Pilots	6
Electronic Ignitions Systems	6
Caution	8
Maintenance and Care Procedures	9
Pool & Spa Water Chemistry	9
INSTALLATION & SERVICE INSTRUCTIONS	10
Receiving Equipment	10
General Specifications	10
Installation Instructions	10
Clearances	11
Combustion Air	12
Vent Piping	13
Gas Supply Connections	14
Plumbing for Water Connections	15
Piping Diagrams	16
Electrical Wiring	18
Wiring Diagram—Models 514–724	20
Wiring Diagram—Model 824	21
Wiring Diagram—Models 514–724—Spa	22
Wiring Diagram—Model 824—Spa	23
Servicing	24
Troubleshooting	29
Replacement Parts	32

WARNINGS

Pay Attention to These Terms

DANGER:	Indicates the presence of immediate hazards which will cause severe personal injury, death or substantial property damage if ignored.
WARNING:	Indicates the presence of hazards or unsafe practices which could cause severe personal injury, death or substantial property damage if ignored.
CAUTION:	Indicates the presence of hazards or unsafe practices which could cause minor personal injury or product or property damage if ignored.
NOTE:	Indicates special instructions on installation, operation, or maintenance which are important but not related to personal injury hazards.

DANGER: Failure to install the draft hood on indoor installations and properly vent the heater to the outdoors as outlined in the Venting section of this manual can result in unsafe operation of the heater. To avoid the risk of fire, explosion, or asphyxiation from carbon monoxide, never operate this heater unless it is properly vented and has an adequate air supply for proper operation. Be sure to inspect the vent system for proper installation at initial start-up; and at least annually thereafter. Refer to the Maintenance section of this manual for more information regarding vent system inspections.

DANGER: Make sure the gas on which the heater will operate is the same type as that specified on the heater rating plate.

DANGER: There is a Hot Water SCALD Potential if the poolstat is set too high.

DANGER: When servicing or replacing components that are in direct contact with the water, be certain that:

- There is no pressure in the heater. (Pull the release on the relief valve. Do not depend on the pressure gauge reading).
- The heater water is not hot.
- The electrical power is off.

WARNING: This product must be installed by a licensed plumber or gas fitter when installed within the Commonwealth of Massachusetts.

WARNING: Should overheating occur or the gas supply valve fail to shut, do not turn off or disconnect the electrical supply to the heater. Instead, shut off the gas supply at a location external to the heater.

WARNING: Both natural gas and propane have an odorant added to aid in detecting a gas leak. Some people may not physically be able to smell or recognize this odorant. If you are unsure or unfamiliar with the smell of natural gas or propane, ask your local gas supplier. Other conditions, such as "odorant fade," which causes the odorant to diminish in intensity, can also hide, camouflage, or otherwise make detecting a gas leak by smell more difficult.

WARNING: UL recognized fuel gas detectors are recommended in all enclosed propane and natural gas applications wherein there is a potential for an explosive mixture of fuel gas to accumulate and their installation should be in accordance with the detector manufacturer's recommendations and/or local laws, rules, regulations, or customs.

WARNING: To minimize the possibility of improper operation, serious personal injury, fire, or damage to the heater:

- Always keep the area around the heater free of combustible materials, gasoline, and other flammable liquids and vapors.
- Heater should never be covered or have any blockage to the flow of fresh air to the heater.

WATER CHEMISTRY

NOTE: Heat exchanger damage resulting from chemical imbalance is not covered under the warranty.

For your health and the protection of your pool equipment, it is essential that your water be chemically balanced. The following levels must be used as a guide for balanced water.

- Occasional chemical shock dosing of the pool or spa water should not damage the heater providing the water is balanced.

- Automatic chemical dosing devices and salt chlorinators are usually more efficient in heated water; unless controlled, they can lead to excessive chlorine level which can damage your heater.
- Further advice should be obtained from your pool or spa builder, accredited pool shop, or chemical supplier for the correct levels for your water.

Recommended Level(s)	Fiberglass Pools	Fiberglass Spas	Other Pool and Spa Types
Water Temperature	68-88°F (20-31°C)	89-104°F (31-40°C)	68-104°F (20-40°C)
pH	7.3-7.4	7.3-7.4	7.6-7.8
Total Alkalinity (ppm)	120-150	120-150	80-120
Calcium Hardness (ppm)	200-300	150-200	200-400
Salt (ppm)	6000 Maximum	6000 Maximum	6000 Maximum
Free Chlorine (ppm)*	2-3	2-3	2-3
Total Dissolved Solids (ppm)	3000 Maximum	3000 Maximum	3000 Maximum

*Free Chlorine **MUST NOT EXCEED 5 ppm!**

Table A: Water Chemistry

OWNER'S OPERATING INSTRUCTIONS

FOR YOUR SAFETY - READ BEFORE OPERATING: WARNING: If you do not follow these instructions exactly, a fire or explosion may result, causing property damage, personal injury or death.

Start-Up Procedures

Before Start-Up

Burners

Clean main burners and air louvers of dust, lint and debris. Keep heater area clear and free from combustibles, flammable liquids and chemicals. Do not obstruct the flow of combustion and ventilating air.

Water

First thing, ensure that system is filled with water and have pump operating. Water must be flowing through the heater during operation.

CAUTION: Propane gas is heavier than air and will settle on the ground. Since propane can accumulate in confined areas, extra care should be exercised when lighting propane heaters.

Operating Instructions and Shut-Off Procedures

Automatically Lighted Pilots Electronic Ignitions Systems

- A. This appliance is equipped with an ignition device which automatically lights the pilot. Do not try to light the pilot by hand.
- B. **BEFORE OPERATING**, smell all around the appliance area for gas. Be sure to smell next to the floor because some gas is heavier than air and will settle on the floor.

WHAT TO DO IF YOU SMELL GAS:

- Do not try to light any appliance.
 - Do not touch any electric switch; do not use any telephone in your building.
 - Immediately call your gas supplier from a neighbor's telephone. Follow the gas supplier's instructions.
 - If you cannot reach your gas supplier, call the fire department.
- C. Use only your hand to push in or turn the gas control knob. Never use tools. If the knob will not push in or turn by hand, do not try to repair it; call a qualified service technician. Force or attempted repair may result in fire or explosion.
 - D. Do not use this appliance if any part has been under water. Immediately call a qualified service technician to inspect the appliance and to replace any part of the control system and any gas control which has been under water.

OPERATING INSTRUCTIONS

1. **STOP!** Read the safety information on the preceding page.
2. Set the poolstat on the lowest setting.
3. Turn off all electric power to the appliance.
4. Remove heater door panel.
5. This appliance is equipped with an ignition device which automatically lights the pilot. Do not try to light the pilot by hand.
6. **For Models 514-724 with Honeywell Gas Valve.** Push in gas control knob slightly and turn clockwise  to "OFF". Knob cannot be turned to "OFF" unless knob is pushed in slightly. Do not Force.

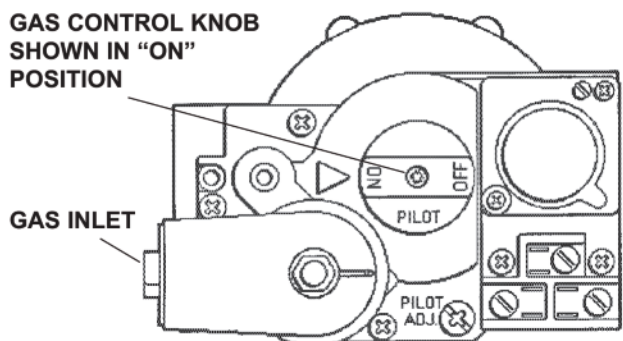

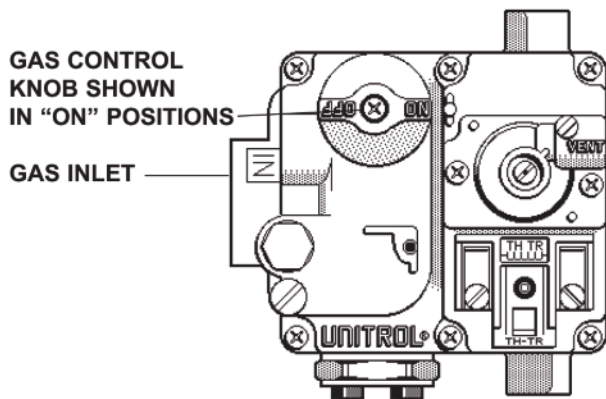

For Models 514-724 with Robertshaw/Invensys Gas Valve. Turn Gas control knob clockwise  to "OFF".

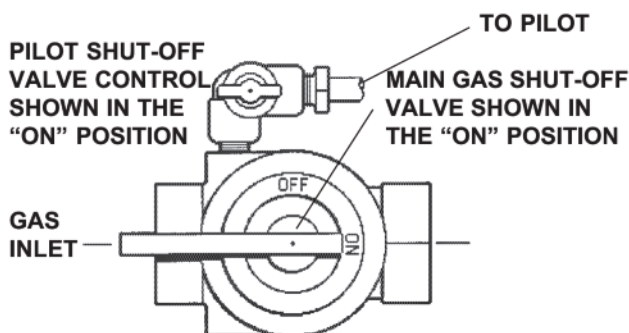

For Model 824

Turn main gas shut-off and pilot shut-off valves counter clockwise  to "OFF".



7. Wait five (5) minutes to clear out any gas. Then smell for gas, including near the floor. If you smell gas, STOP! Follow "B" in the safety information located on page 6. If you don't smell gas, go to the next step.
8. **For Models 514-724**
Turn gas control knob counter clockwise  to "ON"

For Model 824

Turn main gas shut-off and pilot shut-off valves clockwise  to "ON".

9. Replace heater door panel.
10. Turn on all electric power to the appliance.
11. Set poolstat to desired setting.
12. If the appliance will not operate, follow the instructions "To Turn Off Gas to Appliance" and call your service technician or gas supplier.

TO TURN OFF GAS TO APPLIANCE

1. Set the poolstat to the lowest setting.
2. Turn off all the electric power to the appliance if service is to be performed.
3. Remove heater door panel.
4. **For Models 514-724**

Push in gas control knob slightly and turn clockwise  to "OFF".

For Models 824

Turn main gas shut-off and pilot shut-off valves counter clockwise  to "OFF".

5. Replace heater door panel.

After Start-Up

Feel the inlet and outlet pipes. Outlet pipe should be only slightly warmer than the inlet. It should not be hot.

WARNING: Should overheating occur or the gas supply fail to shut off, turn off the manual gas control to the appliance.

Visual Inspection

With the heater on, remove the door and make a visual check of the pilot and burner. The flame should be blue with a well-defined pattern.

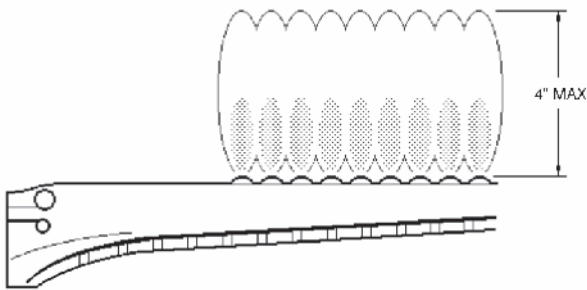

Fig. 1: Main Burner Flame



Fig. 2: Pilot Burner Flame

A yellow or "floating" flame indicates restricted air openings or incorrect orifice size. Should this occur, shut the heater off and contact your installer or gas supplier.

Water Pressure Switch

A water pressure switch is provided in the heater to shut off the burners in the event that water supply to the heater is interrupted. It is very important to verify that the switch electrically opens and shuts off the gas valve when water flow to the heater is interrupted. Otherwise, rapid and severe damage will likely occur to the heater. (The water pressure switch should be

checked and adjusted for proper operation by a qualified service person at the time of installation and periodically checked thereafter. Refer to pressure switch servicing instruction in this manual).

WARNING: Operation of the heater without water circulation will cause rapid and severe damage to the heater. Such damage is not covered under warranty.

Caution

Elevated water temperature can be hazardous, and the U.S. Consumer Product Safety Commission recommends the following guidelines:

1. Spa or hot tub water temperatures should never exceed 104°F (40°C). A temperature of 100°F (38°C) is considered safe for a healthy adult. Special caution is suggested for young children.
2. Drinking of alcoholic beverages before or during spa or hot tub use can cause drowsiness which could lead to unconsciousness and subsequently result in drowning.
3. Pregnant Women Beware! Soaking in water over 102°F (39°C) can cause fetal damage during the first three months of pregnancy, resulting in the birth of a brain damaged or deformed child. Pregnant women should stick to the 100°F (38°C) maximum rule.
4. Before entering the spa or hot tub, users should check the water temperature with an accurate thermometer; spa or hot tub thermostats may err in regulating water temperatures by as much as 4°F (2.2°C).
5. Persons with a medical history of heat disease, circulatory problems, diabetes, or blood pressure problems should obtain a physician's advice before using pools or hot tubs.
6. Persons taking medications which induce drowsiness, such as tranquilizers, antihistamines, or anticoagulants, should not use spas or hot tubs.

Maintenance and Care Procedures

To be followed one month after start-up and then semi-annually.

1. Inspect top of heater and drafthood for soot, (a sticky black substance around finned tubes and "V" baffles), and open flue gas passageways.

CAUTION: Soot may be combustible. Wet sooted surfaces completely prior to cleaning. Do not use steel wire brush.

2. Clean main burners and pilot burner of dust and lint.
3. Inspect and operate all controls, gas valve and pressure relief valve.
4. Make visual check of the burner and pilot flame. Flame pattern on the main burner and pilot is indicated in the previous illustration. Yellow flame means restriction of the air openings. Lifting or blowing flame indicates high gas pressure. Low flame means low gas pressure. Should this occur, shut the heater off and contact your gas supplier or qualified service agency.
5. On indoor heater, clean room air intake openings to ensure adequate flow of combustion and ventilation air.

CAUTION: Combustion air must not be contaminated by corrosive chemical fumes which can damage the heater and void the warranty.

6. Keep air around heater clear and free from combustible materials, gasoline and other flammable and corrosive vapors and liquids.

Basic Tips If Heater Will Not Fire

1. If you have no electrical power, it may be that your circuit breakers" have tripped. Try re-setting them.
2. If you have electrical power but the heater will not fire, check the following:
3. The time clock must be moved to the "ON" position.

4. Your pump strainer basket may be full. If so remove debris.
5. Your filter may be dirty. If so, backwash or clean filter. (To tell if your filter is dirty, the gauge pressure will be higher than usual).
6. The pump may have lost its prime. It may be running dry, check the pressure gauge on the filter. If there is no pressure; then you are not moving water (or your gauge is broken). Try to get the pump to run at it's normal flow rate.

Pool & Spa Water Chemistry

Chemical imbalance can cause severe damage to your heater and associated equipment. Maintain your water chemistry according to the chart on page 5. If the mineral content and dissolved solids in the water become too high, scale forms inside the heat exchanger tubes, reducing heater efficiency and also damaging the heater, If the pH drops below 7.2, the heater will be severely damaged. This will result in corrosion of the heat exchanger. **Heat exchanger damage resulting from chemical imbalance is not covered by the warranty.**

When heaters installed outdoors in freezing climate areas are to be shut down for the winter, observe the following step-by-step procedure:

1. Turn off gas valve, manual gas valve, and electrical supply to the heater.
2. Open drain cock located on the inlet/outlet header, (under water pipes).
3. Disconnect compression fittings from the pressure switch and return header that connect to the 1/4" copper tube and allow the tube to drain.

INSTALLATION & SERVICE INSTRUCTIONS

Receiving Equipment

On receipt of your equipment it is suggested that you visually check for external damage to the carton. If the carton is damaged, a note should be made on the Bill of Lading when signing for equipment. Remove the heater from the carton and if it is damaged, report the damage to the carrier immediately.

On occasion, we ship some items loose. Be sure that you receive the number of packages indicated on the Bill of Lading.

When ordering parts, you must specify model and serial number of heater. When ordering under warranty conditions, you must also specify date of installation.

Raypak recommends that this manual be reviewed thoroughly before installing your Raypak pool/spa heater. If there are any questions that this manual does not answer, please contact the factory or your local Raypak representative.

General Specifications

These heaters are design-certified and tested under the requirements of ANSI Z21.56/CSA 4.7 American National Standard for Gas-Fired Pool Heaters.

All heaters are interchangeable and can be used either indoor or outdoors. The appropriate top designated for that type of use is required. If desired, the top can be changed at a later date from outdoor to indoor or vice versa.

Rated inputs suitable for natural gas at elevations up to 2000 feet. For propane inputs, multiply the natural gas rating by 0.94.

For elevations above 2000 feet, reduce input 4% for each 1000 feet above sea level, as height elevation reduces combustion performance.

Installation Instructions

NOTE: These instructions are intended for the use of qualified personnel only, specifically trained and experienced in the installation of this type of heating equipment and related system components. Installation and service personnel may be required by some states to be licensed. If your state is such, be sure your contractor bears the appropriate license. Persons not qualified shall not attempt to fix this equipment nor attempt repair according to these instructions.

WARNING: Improper installation, adjustment, alteration, service or maintenance may damage the equipment, create a hazard resulting in asphyxiation, explosion or fire, and will void the warranty.

Code Requirements

NOTE: The heater should not be located in an area where possible water leakage will result in damage to the area adjacent to the appliance or to the structure. When such locations cannot be avoided, it is recommended that a suitable drain pan, adequately drained, be installed under the appliance. The pan must not restrict combustion air flow.

Installation must be in accordance with local codes, or, in the absence of local codes, with the latest edition of the National Fuel Gas Code (NFPA), ANSI Z223.1/NFPA 54 and National Electrical Code (NEC), ANSI/NFPA 70.

Base Installation

Heater must be mounted on a level base, such as cement slab, cement blocks or other non-combustible surface. An optional non-combustible base is available for all models. An alternative method for providing a base for combustible floors is illustrated in Fig. 3. Heater must not be installed on carpeting.

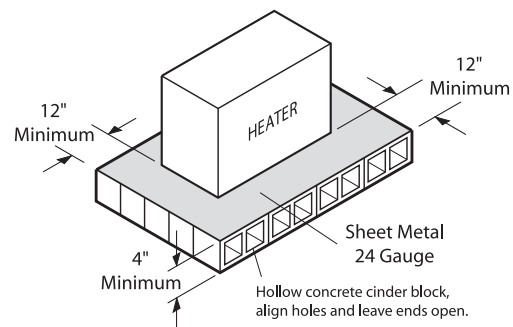

Fig. 3: Alternate Mounting Base

Clearances

All Heaters

For clearances from combustible surfaces, see Table B.

Heater Side	Min. Clearance from Combustible Surfaces	
	Indoor	Outdoor
Top (Indoor)	See note 1	
Top (Outdoor)		Unobstructed
Front	Alcove	
Back	10"	10"
Water Side	6"	6"
Other Side	6"	6"
Vent	6"	
Floor	See note 2	See note 3

NOTE 1 - 36" minimum from top of vent terminal.

NOTE 2 - Must not be installed on carpeting. Combustible floor base required for installation on a combustible surface

NOTE 3 - Combustible floor shield optional for outdoor installation.

NOTE 4 - For servicing, provide at least 24" in front of the heater for burner tray removal, and at least 18" on water connection side of the heater to inspect and delime the heat exchanger.

Table B: Minimum Clearances from Combustible Construction

Outdoor Heaters

These heaters are design-certified for outdoor installation, when equipped with the approved tops designated for outdoor use.

Heaters must not be installed under an overhang of less than three (3) feet from the top of the heater. Three (3) sides must be open in the area under the overhang. Roof water drainage must be diverted away from the heaters installed under overhangs with the use of gutters.

WARNING: The heater shall not be located in an area where water sprinklers, or other devices, may cause water to spray through the cabinet louvers and into the heater. This could cause heavy internal rusting or damage some electrical components, and this would void the warranty.

The point from where the flue products exit the heater must be a minimum of four (4) feet below, four (4) feet horizontally from or one (1) foot above any door, window or gravity inlet to a building. The top surface of the heater shall be at least three (3) feet above any forced air inlet, or intake ducts located within ten (10) feet horizontally.

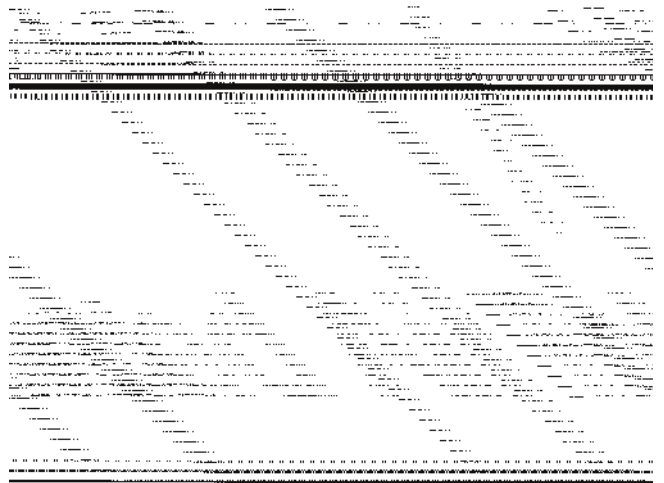

Fig. 4: Minimum Distance from Openings

High Wind Conditions (Outdoor Units Only)

In areas where high winds are frequent, it may be necessary to locate the heater a minimum of 3' from high vertical walls, or install a wind break so the heater is not in direct wind current.

Indoor Heaters

The design is also certified for indoor installation when equipped with the approved draft hood and (if necessary) combustible floor shield. Locate heater as close as practical to a chimney or gas vent. Heater must always be vented to the outside. See Vent Piping Section on page 13 for venting details. Minimum allowable space is shown on the nameplate.

Combustion Air (Indoor Units Only)

Air For Combustion and Ventilation (Indoor Units Only)

The heater must have both combustion and ventilation air. Minimum requirements for net free air supply openings, one 12 inches from ceiling for ventilation and one 12 inches from the floor for combustion air as outlined in the latest edition of ANSI Z 223.1/NFPA 54 and any local codes that may have jurisdiction.

CAUTION: Combustion air must not be contaminated by corrosive chemical fumes which can damage the heater and void the warranty.

- a. All air from inside the building:
Each opening shall have a minimum net free square inches as noted in Table C.

Model	Square Inches
514	512
624	627
724	726
824	825

Table C: Air from Inside the Building

- b. All air from outdoors:
 When air is supplied directly from outside of building, **each opening** shall have a minimum net free square inches as noted in Table D.

Model	Square Inches
514	128
624	157
724	182
824	207

Table D: Air from Outside the Building

Venting Connections

Vent Terminal (Outdoor)

1. Lower outdoor "Stackless" top on to unit. Position top so it is centered on unit from side to side and front to rear.

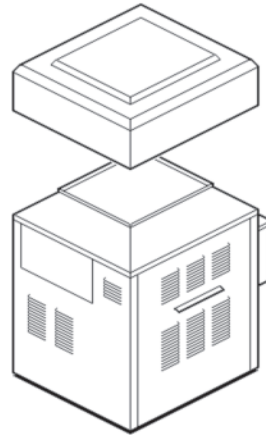

Fig. 5: Lower Outdoor "Stackless" Top Onto Unit

2. Tighten the (4) screws (See Fig. 6) until they come in contact with the unit jacket top, then evenly tighten all (4) screws to secure to unit.

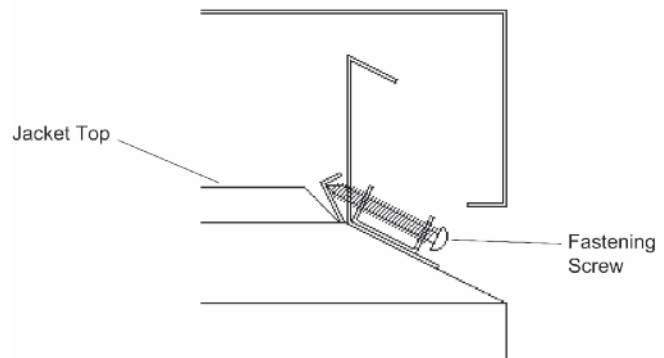

Fig. 6: Tighten the (4) Screws (TYP.)

Vent Terminal (Indoor)

Locate and assemble as shown below. Secure with screws supplied in envelope in carton.

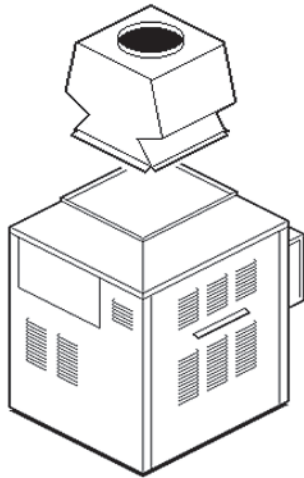

Fig. 7: Vent Terminal (Indoor)

Vent Piping

WARNING: Indoor heaters require a draft hood that must be connected to a vent pipe and properly vented to the outside. Failure to follow this procedure can cause fire or fatal carbon monoxide poisoning.

Vent piping the same size or larger than the draft hood outlet is recommended (but not to exceed listing in chapter 13 of ANSI Z 223.1/NFPA 54), however, when the total vent height is at least ten (10) feet (draft hood relief opening to vent terminal), the vent pipe size may be reduced as specified in Chapter 13 of the latest edition of the National Fuel Gas Code, ANSI Z 223.1/NFPA 54.

As much as possible avoid long horizontal runs of vent pipe and too many elbows. If installation requires horizontal non-vertical runs, the vent pipe must have a minimum of 1/4 inch per foot rise and should be supported at not less than five-foot intervals. Plumber's tape, crisscrossed, will serve to space both horizontal and vertical piping. Gas vents supported only by the flashing and extending above the roof more than five feet should be securely guyed or braced to withstand snow and wind loads. We recommend use of insulated vent pipe spacer through the roofs and walls.

For protection against rain or blockage by snow, the vent pipe must terminate with a vent cap which complies with the local codes or, in the absence of such

codes, to the latest edition of the National Fuel Gas Code, ANSI Z 223.1/NFPA 54.

The discharge opening must be a minimum of two feet vertically from the roof surface and at least two feet higher than any part of the building within ten feet. Vent stack shall be at least five feet in vertical height above the draft hood outlet.

The vent cap location shall have a minimum clearance of 4 feet horizontally from, and in no case above or below, unless a 4-foot horizontal distance is maintained, from electric meters, gas meters, regulators and relief equipment.

The weight of the vent stack or chimney must not rest on heater draft hood. Support must be provided in compliance with applicable codes. The heater top and draft hood must be readily removable for maintenance and inspection. Vent pipe should be adequately supported to maintain proper clearances from combustible constructions.

Type "B" double-wall or equivalent vent pipe, certified for Category I vent conditions, is recommended. However, single-wall metal vent pipe may be used as specified in the latest edition of the National Fuel Gas Code ANSI Z 223.1/NFPA 54.

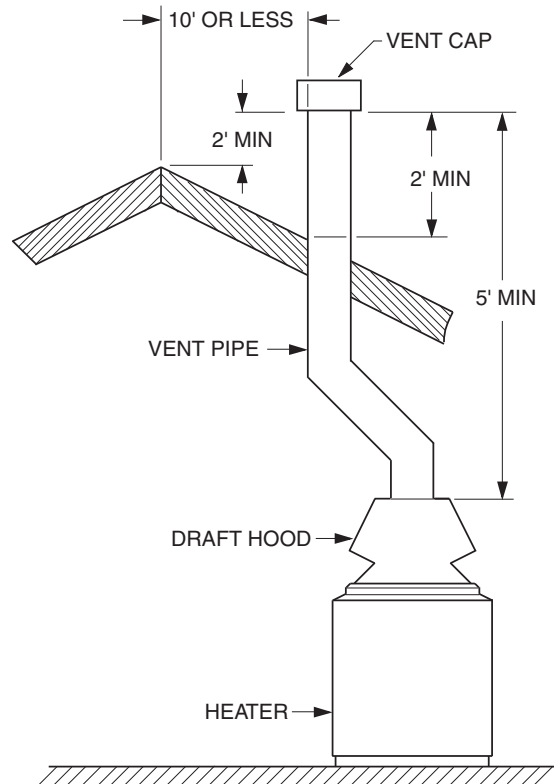

Fig. 8: Venting Clearances

At the time of removal of an existing heater, the following steps shall be followed with each appliance remaining connected to the common venting system placed in operation, while the other appliances remaining connected to the common venting system are not in operation.

- (a) Seal any unused openings in the common venting system.
- (b) Visually inspect the venting system for proper size and horizontal pitch and determine there is no blockage or restriction, leakage, corrosion and other deficiencies which could cause an unsafe condition.
- (c) Insofar as is practical, close all building doors and windows and all doors between the space in which the appliance remaining connected to the common venting system are located and other spaces of the building. Turn on clothes dryers and any appliance not connected to the common venting system. Turn on any exhaust fans, such as range hoods and bathroom exhausts, so they will operate at maximum speed. Do not operate a summer exhaust fan. Close fire place dampers.
- (d) Place in operation the appliance being inspected. Follow the lighting instructions. Adjust thermostat so appliance will operate continuously.
- (e) Test for spillage at the draft hood relief opening after 5 minutes of main burner operation. Use the flame of a match or candle, or smoke from a cigarette, cigar or pipe.
- (f) After it has been determined that each appliance remaining connected to the common venting system properly vents when tested as outlined above, return doors, windows, exhaust fans, fireplace dampers and any other gas burning appliance to their previous conditions of use.
- (g) Any improper operation of the common venting system should be corrected so the installation conforms with the latest edition of the National Fuel Gas Code, ANSI Z 223.1/ NFPA 54. When re-sizing any portion of the common venting system, the common venting system should be re-sized to match the minimum size as determined using the appropriate tables in part 11 of national Fuel Gas Code, ANSI Z 223.1/NFPA 54.

For special venting applications that require reduced vent sizes and through the wall venting, the Type D Induced Draft Assembly can be used. Consult the factory or your local Raypak representative.

Gas Supply Connections

Gas piping must have a sediment trap ahead of the heater gas controls, and a manual shut off valve located outside the heater jacket. All gas piping should be tested after installation in accordance with local codes.

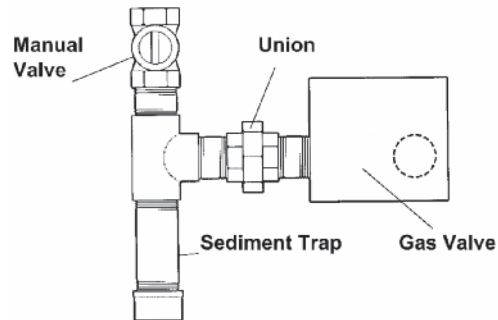

Fig. 9: Gas Connections

CAUTION: The heater and its manual shut off valve must be disconnected from the gas supply during any pressure testing of that system at test pressures in excess of 1/2 Psig (3.45 KPA). Dissipate test pressure in the gas supply line before reconnecting the heater and its manual shut off valve to gas supply line. FAILURE TO FOLLOW THIS PROCEDURE MAY DAMAGE THE GAS VALVE. OVER-PRESSURIZED GAS VALVES ARE NOT COVERED BY WARRANTY. The heater and its gas connections shall be leak tested before placing the appliance in operation. Use soapy water for leak test. Do NOT use open flame.

NOTE: Do not use teflon tape on gas line pipe thread. A flexible sealant approved for the fuel being used is recommended.

A minimum of 7 in. WC and a maximum of 10.5 in. WC upstream pressure under load, and no-load conditions must be provided for natural gas or a minimum of 12 in. WC and a maximum of 13 in. WC for propane gas.

Gas Pressure Regulator

The gas pressure regulator is preset and sealed at 4 in. WC for natural gas, and 11 in. WC for propane gas. Between the gas valve and the burners is a 1/8" pipe plug. The pressure at this point, taken with a manometer, should be about 3.7 in. WC natural gas and 10.5 in. WC propane gas. If an adjustment is needed, remove seal and turn adjustment screw clockwise to increase pressure or counter clockwise to decrease pressure.

Model	1/2"		1"		1-1/4"		1-1/2"		2"		2-1/2"	
	N	P	N	P	N	P	N	P	N	P	N	P
514		10	15	35	65	150	130	360	500			
624			10	25	45	100	95	250	340			
724				20	35	80	75	180	260	600		
824				15	25	60	55	130	185	480	500	

Natural gas, 1000 BTU/Ft .60 Specific Gravity @ 0.5 in. WC Pressure Drop
 Propane Gas, 2500 BTU/Ft 1.53 Specific Gravity @ 0.6 in. WC Pressure Drop

Table E: Pipe Sizing for Gas Connections

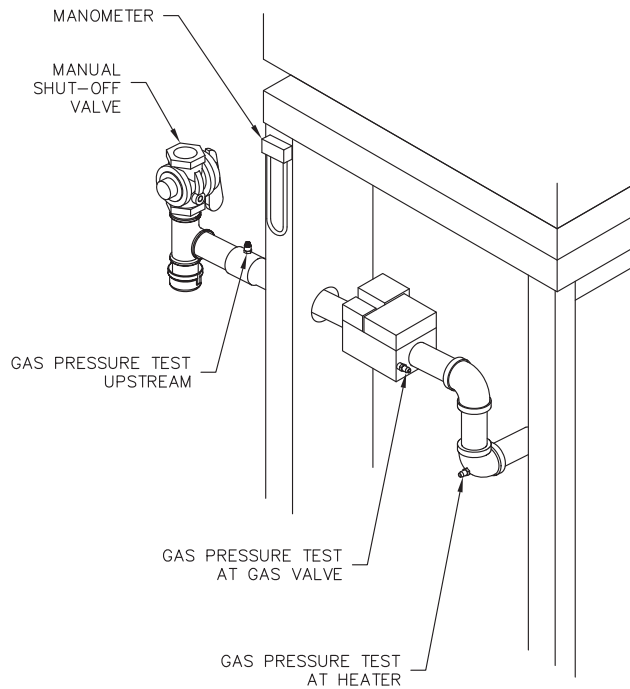

Fig. 10: Gas Pressure Test Points

The heater must be located so that any water leaks will not damage the structure of adjacent area. High-temperature plastic pipe (CPVC) may be connected directly into the heater if local codes permit and if controls operate the pump for at least fifteen minutes after the heater is turned off.

CAUTION: NEVER install PVC directly into heater. Four feet of copper or high-temperature pipe and two elbows are required between the heater and the PVC connections

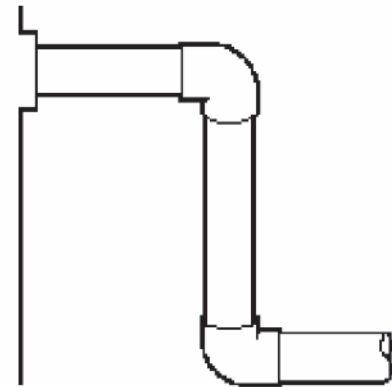

Fig. 11: Water Piping Connections

Plumbing For Water Connections

Location

The heater requires water flow and positive pressure to fire and operate properly. It must therefore be installed downstream of the discharge side of the filter pump. A typical installation is plumbed as follows:

1. The inlet side of the filter is plumbed directly to the discharge side of the filter pump;
2. The outlet side of the filter is then plumbed to the inlet of the heater; and
3. The outlet of the heater is plumbed to the return line to the pool or spa. The pump, filter and heater are thus plumbed in series.

When local codes permit the use of less than four feet high-temperature piping or two elbows, provisions should be made to always shut the heater off a minimum of 15 minutes prior to pump shut down in order to carry away residual heat and prevent damage to the low temperature piping.

A fireman switch included in the time clock may be used for this purpose with instruction not to override this sequence manually. See wiring diagram section for electrical hookup location of the fireman switch in the electrical circuit.

Piping Diagram—Single Heater

MINIMUM PIPE SIZES		
	BRANCH	MAIN
514-824	2"	2-1/2"

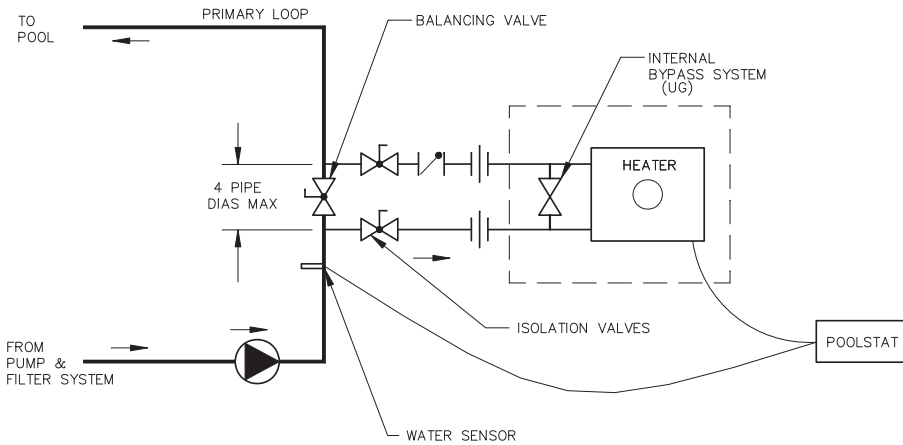

NOTES:

1. PLUMB SWING CHECK VALVE IN GRAVITY-CLOSED POSITION.
2. PIPE ALL RELIEF VALVES TO DRAIN, OR AS LOCAL CODES REQUIRE.
3. MINIMUM PIPE SIZE MUST BE EQUAL TO THE BOILER INLET/ OUTLET SIZE. SEE "MINIMUM PIPE SIZES" CHART ABOVE.

KEY	
	PRESSURE RELIEF VALVE
	PUMP
	UNION
	CHECK VALVE
	BALL VALVE
	THERMOMETER

Piping Diagram—Two Heaters

PIPE SIZES		
	BRANCH	MAIN
514-824	2"	3"

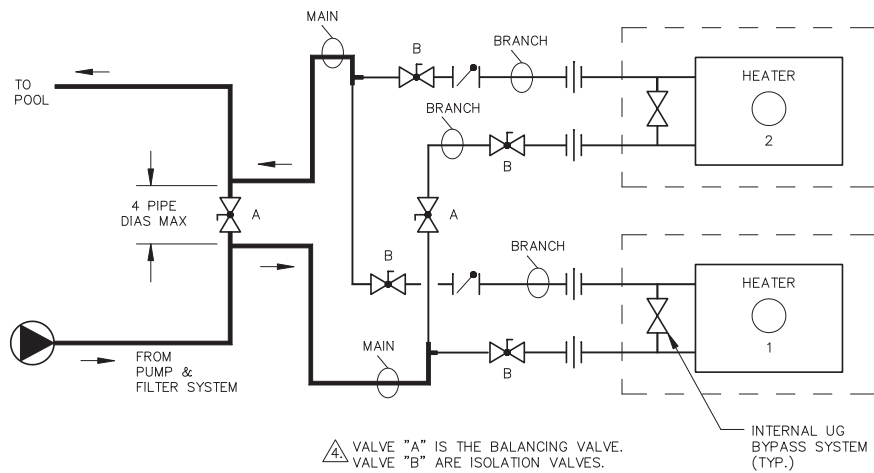

⚠ VALVE "A" IS THE BALANCING VALVE. VALVE "B" ARE ISOLATION VALVES.

NOTES:

1. PLUMB SWING CHECK VALVE IN GRAVITY-CLOSED POSITION.
2. PIPE ALL RELIEF VALVES TO DRAIN, OR AS LOCAL CODES REQUIRE.
3. MINIMUM PIPE SIZE MUST BE EQUAL TO THE HEATER INLET / OUTLET SIZE. SEE "PIPE SIZES" CHART ABOVE.

⚠ SET BALANCING VALVE ON STARTUP AND LOCK THE SETTING.

KEY	
	PRESSURE RELIEF VALVE
	PUMP
	UNION
	CHECK VALVE
	BALL VALVE
	THERMOMETER

NOTE: When 2" piping is used into the heater, this piping must be anchored (copper) or screwed into the flange (metal) if operating pressures above 30 PSI are encountered.

NOTE: Any restrictions between heater outlet and pool will void the warranty.

Model	Pipe Size	Min. gpm	Max. gpm
514 - 824	2"	60	120

Table F: Flow Rates

Companion Flange Connections

DO NOT use petroleum base assembly fluids (such as Petroleum Jelly or lubricating oil). If assembly tube is required use a silicone base such as Armoral etc. The inlet/outlet header flange accepts a 2" copper tube as a slip connection directly into the header. The flange is also threaded for a 2" copper male threaded adapter.

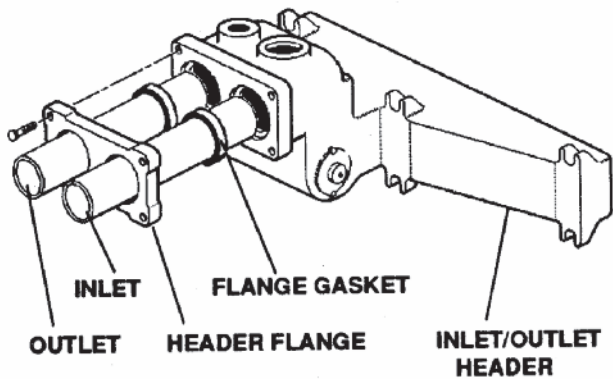

Fig. 12: Flange Connections

Automatic Chlorinators and Chemical Feeders

All chemicals must be introduced and completely diluted into the pool or spa water before being circulated through the heater. Do not place chlorine tablets or bromine sticks in the skimmer. High chemical concentrations will result when the pump is not running (i.e. overnight).

Chlorinators must feed downstream of the heater and have an anti-siphoning device to prevent chemical backup into the heater when the pump is shut off.

NOTE: High chemical concentrates from feeders and chlorinators that are out of adjustment will cause very rapid corrosion to the heat exchanger and unwarrantable damage to the heater.

Unitherm Governor Operation

The patented Unitherm Governor is a thermostatic mixing valve specifically designed to maintain constant heater internal temperature between 105°F to 115°F despite continually changing flow rates from the filter and changing pool temperatures. This narrow range is needed to prevent damaging condensation on the burners which will occur if the heater runs for any length of time below 100°F. It is also needed to inhibit scale formation in the tubes by maintaining temperatures well below accelerated scaling temperatures.

External Auxiliary Bypass Valve (Where Required)

An auxiliary bypass valve should be used when flow rates exceed 115 gpm (usually a high-performance pump size larger than two HP will exceed this flow rate). This valve is required to complement the function of the automatic bypass valve, particularly when starting the heater in winter or early spring when the spa or pool temperature is below 55°F. It also serves to eliminate needless pressure drop through the heater and accompanying reduction in the flow rate to the spa jets, etc.

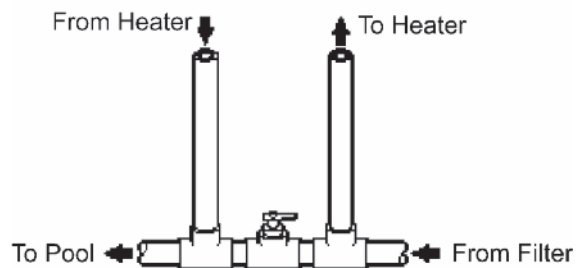

Fig. 13: Auxiliary Bypass Valve

Auxiliary Bypass Valve Adjustment

To set bypass: with clean filter, adjustment is made by feeling the inlet and outlet pipes at the heater. Outlet pipes should be slightly warmer than inlet and comfortable to the touch. If pipe is hot, close bypass; if cold, open bypass.

The heater is also equipped with a manual bypass built into the header. This is in addition to the automatic bypass valve. This may be used with flow rates up to 120 gpm and adjusted as below.

NOTE: Sooting or liming caused by improper bypass adjustment voids the warranty

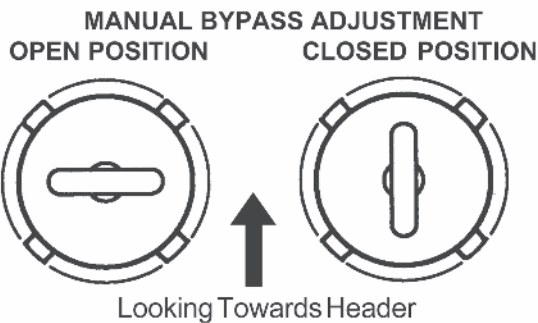
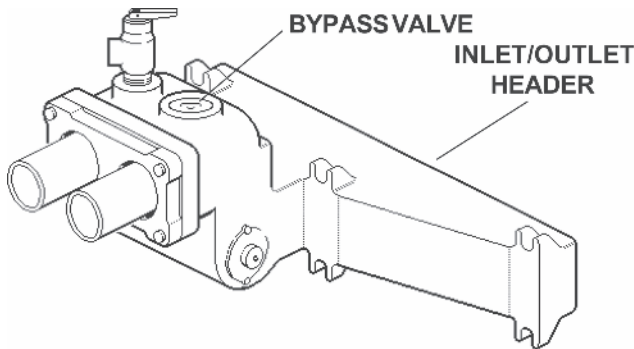

Fig. 14: Manual Bypass Adjustment

Pressure Relief Valve Installation

A 3/4 NPT, 125 psi pressure relief valve (PRV) is standard with this heater. Local building codes may require a PRV with a different pressure setting. The maximum allowable PRV rating is 150 psi. ASME Code requirements mandate that any PRV used must have a relief capacity equal to or larger than the BTU/hr input of the heater.

The standard PRV is mounted in a 3/4 NPT connection on the inlet/outlet header, as shown in Fig. 15. If the required PRV calls for a larger connection, mount it in a tee in the outlet piping and plug the 3/4 NPT port. The PRV must be installed in the vertical position.

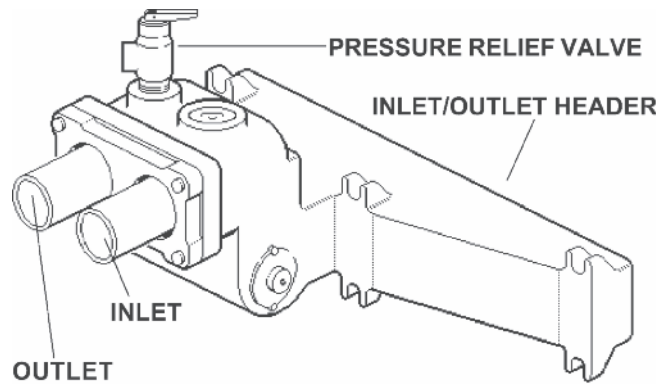

Fig. 15: Pressure Relief Valve Location

To avoid water damage or scalding due to valve operation, drain pipe must be connected to the PRV outlet and run to a safe place of discharge per local code requirements. Drain pipe must be the same size as the PRV discharge connection throughout its entire length and must pitch downward from the PRV. No shutoff valve shall be installed between the PRV and the drain line. Valve lever should be tripped at least once a year to ensure that waterways are clear.

Electrical Wiring

NOTE: If it is necessary to replace any of the original wiring, it must be replaced with 105°C wire or its equivalent, except all black wires must be replaced with 150°C wire or its equivalent.

NOTE: Heaters are factory wired for 240V power supply, except Cal Code units wired for 120V Power Supply.

The heater draws less than 1 amp when operated on either 120VAC or 240VAC power.

The Electronic Intermittent Ignition Device automatically lights the pilot and main burners upon a call for heat. The heater is supplied with a dual voltage transformer for 120V or 240V input power hookup.

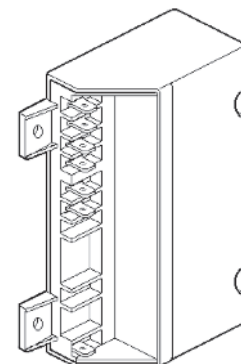

Fig. 16: Ignition Control

For 120 V input power to the unit, connect the black wire to the "L1" or hot leg of the power supply. Connect the white wire to the "L2" or neutral leg of the power supply. Attach the wire nut to the red wire. There should be no connection to the red wire for 120V operation.

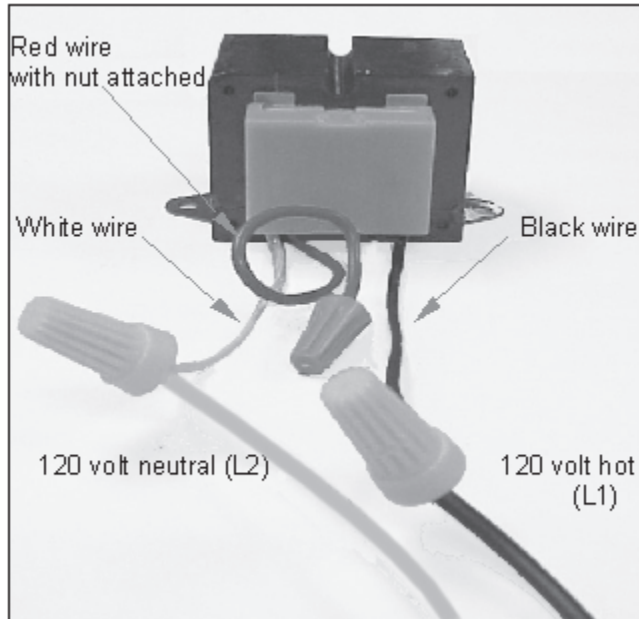

Fig. 17: 120V Connections

For 240 V input power to the unit, connect the black wire to the "L1" or hot leg of the power supply. Connect the red wire to the "L2" or second hot leg of the power supply. Attach the wire nut to the white wire. There should be no connection to the white wire for 240V operation.

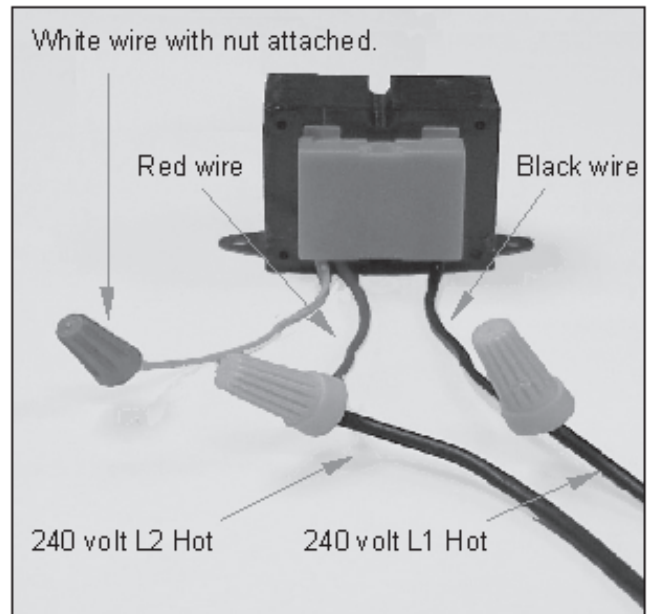

Fig. 18: 240V Connections

Heater must be electrically grounded and bonded in accordance with local codes, or, in the absence of local codes, with the latest edition of the National Electrical code, NFPA 70.

NOTE: Input power to the heater (120/240V) should be supplied from the load (Pump) side of time clock or switch. Connecting heater to continuous power source will allow "Fail" indications (service and pressure switch) when pump is not operating.

NOTE: The wiring diagrams in this manual show all standard options. Refer to the large wiring diagram provided with your heater for options installed on your specific unit(s).

Wiring Diagram—Models 514-724

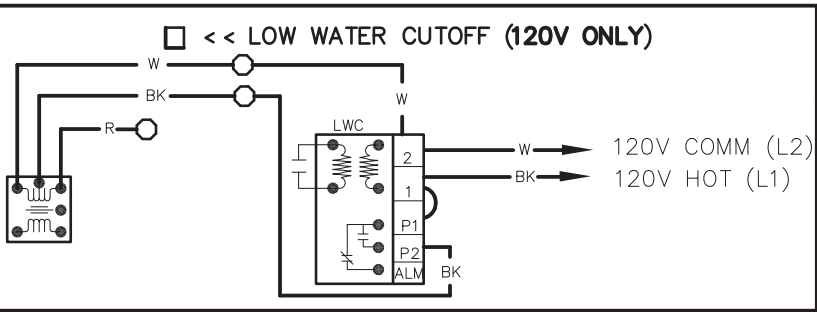
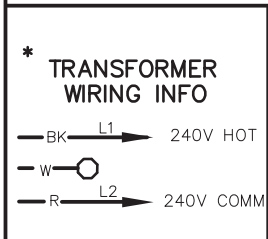
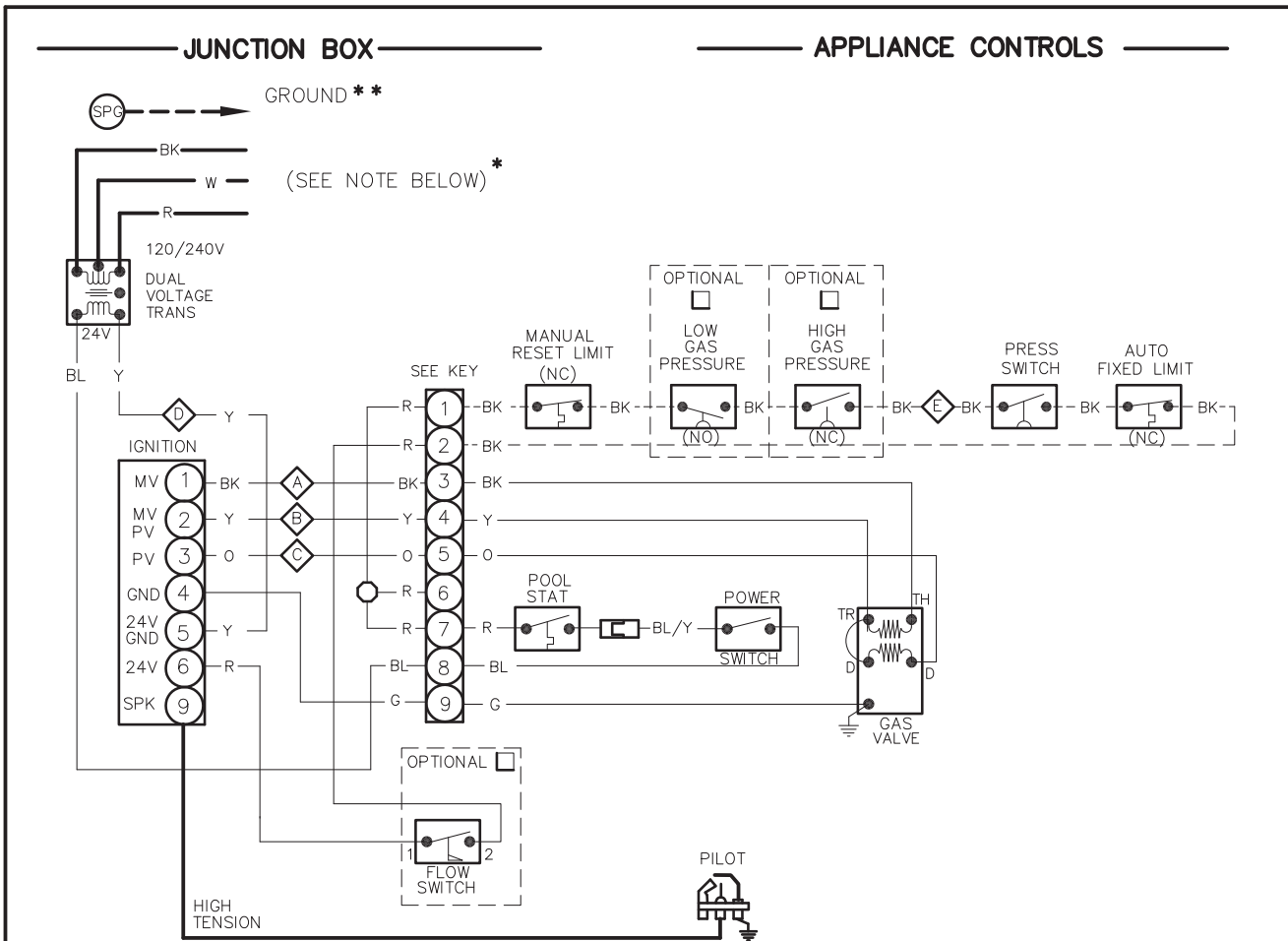

KEY	
	24V 105°C
	24V 150°C
	120V 105°C
	120V 150°C
	GROUND
	WIRE NUT
BK	BLACK
BL	BLUE
BR	BROWN
G	GREEN
O	ORANGE
R	RED
V	VIOLET
W	WHITE
Y	YELLOW
PLUG (ACTUAL)	
FRONT VIEW	

NOTES:
 ALSO USED ON MODEL 824 PROPANE.
****** USE GROUND CONNECTION PROVIDED. FAILURE TO PROVIDE PROPER GROUND MAY RESULT IN LOCK-OUT. ALL GROUND \perp TERMINATE AT .
 CONNECTIONS FOR OPTIONAL E-4 ALARM PANEL.
 CHECK CONTROLS PROVIDED (WIRED AS SHOWN)
 REPLACE WIRING WITH 105°C WIRE ONLY

APPROVED BY:
 CHECKED BY:
 ORIG E.O. **1908**
04/16/84
 CHG E.O. **4000**
03/20/07

WIRING DIAGRAM IID
FIRING MODE - ON/OFF

INPUTS: 512,000 THRU 726,000 BTUH

SIZE: **514-724** TYPE: **P**

151964 13

Wiring Diagram—Model 824

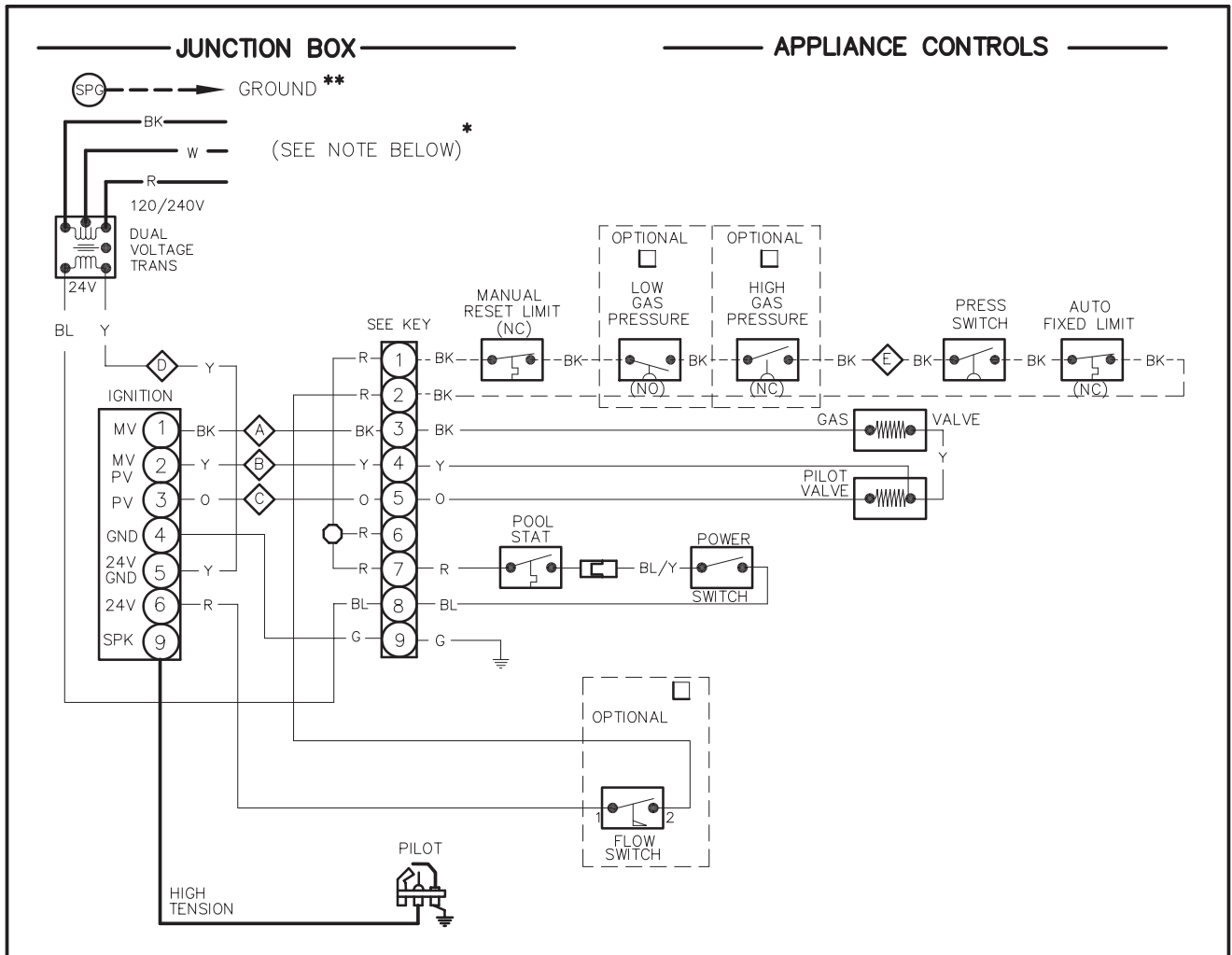

* TRANSFORMER WIRING INFO

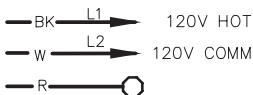
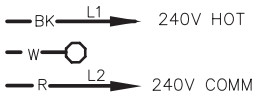

APPROVED BY:

CHECKED BY:

ORIG E.O. 1908

04/16/84

CHG E.O. 3528

12/16/03



□ << LOW WATER CUTOFF (120V ONLY)

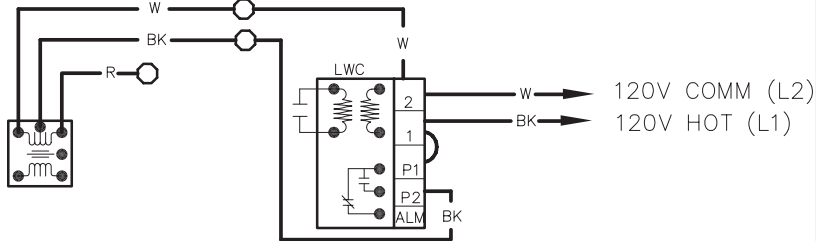

NOTES:

** USE GROUND CONNECTION PROVIDED. FAILURE TO PROVIDE PROPER GROUND MAY RESULT IN LOCK-OUT. ALL GROUND \perp TERMINATE AT SPG .

△ — △ CONNECTIONS FOR OPTIONAL E-4 ALARM PANEL.

☑ CHECK CONTROLS PROVIDED (WIRED AS SHOWN)

REPLACE WIRING WITH 105°C WIRE ONLY

WIRING DIAGRAM IID FIRING MODE — ON/OFF

INPUTS: 825,000 BTUH

SIZE: **824**

TYPE: **P**

KEY

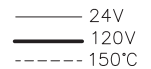

- SPG GROUND
- WIRE NUT
- BK — BLACK
- BL — BLUE
- BR — BROWN
- G — GREEN
- O — ORANGE
- R — RED
- V — VIOLET
- W — WHITE
- Y — YELLOW

PLUG (ACTUAL)

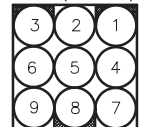

FRONT VIEW

151965 12

Wiring Diagram—Models 514–724—Spa

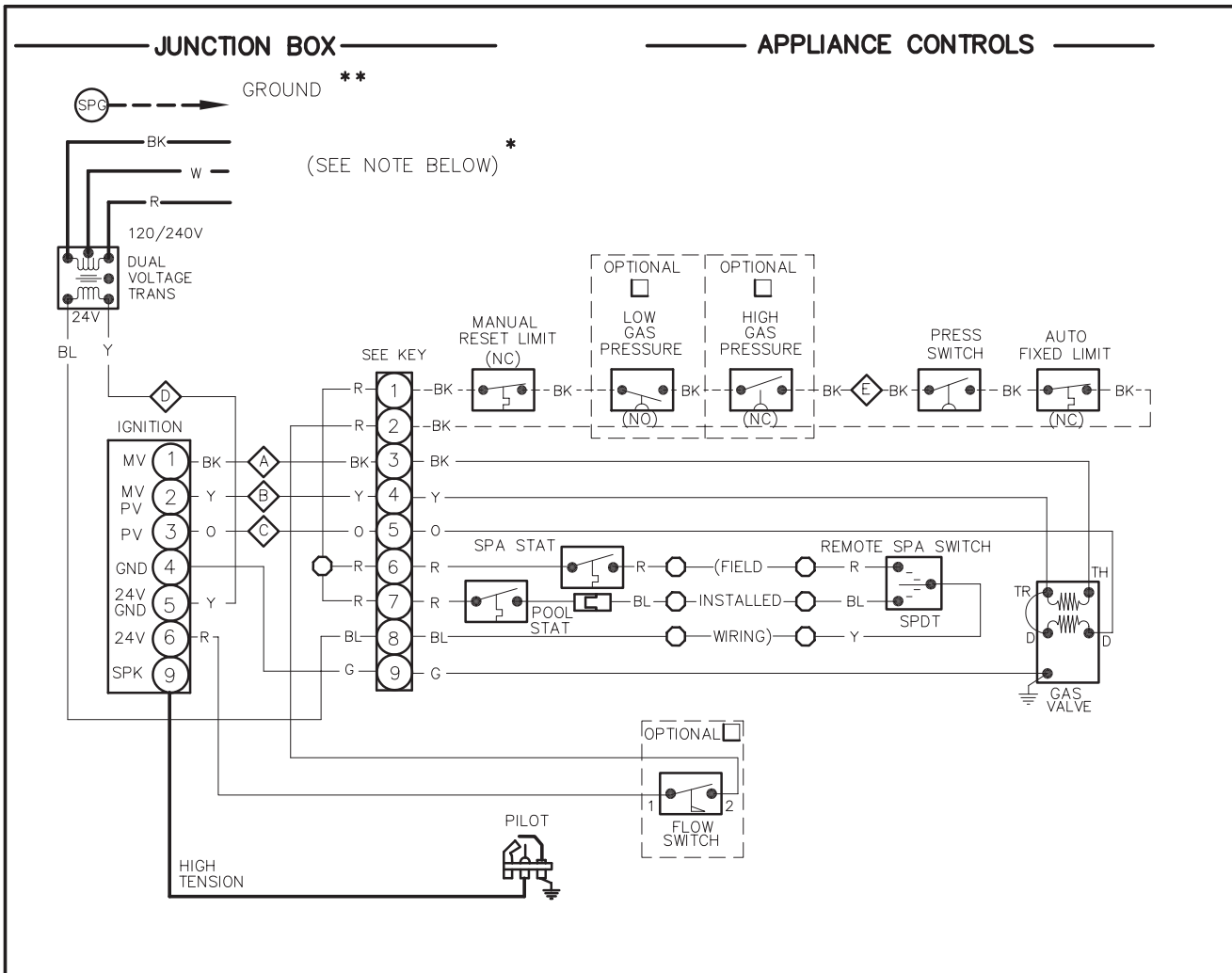

*** TRANSFORMER WIRING INFO**

—BK— L1 → 240V HOT
 —W— L2 → 240V COMM

 —BK— L1 → 120V HOT
 —W— L2 → 120V COMM
 —R—

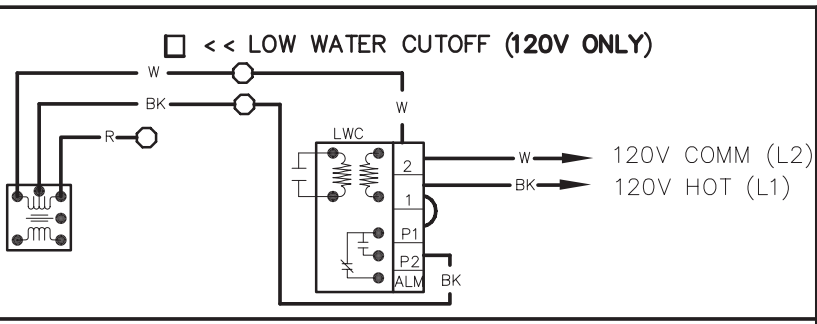

NOTES:

****** USE GROUND CONNECTION PROVIDED. FAILURE TO PROVIDE PROPER GROUND MAY RESULT IN LOCK-OUT. ALL GROUND \perp TERMINATE AT SPG .

\triangle — \diamond CONNECTIONS FOR OPTIONAL E-4 ALARM PANEL.

CHECK CONTROLS PROVIDED (WIRED AS SHOWN)

REPLACE WIRING WITH 105°C WIRE ONLY

KEY

——— 24V
 ——— 120V
 - - - - 150°C

SPG GROUND
 \circ WIRE NUT
 BK — BLACK
 BL — BLUE
 BR — BROWN
 G — GREEN
 O — ORANGE
 R — RED
 V — VIOLET
 W — WHITE
 Y — YELLOW

PLUG (ACTUAL)

3	2	1
6	5	4
9	8	7

FRONT VIEW

APPROVED BY:

CHECKED BY:

ORIG E.O. **2096**

01/03/86

CHG E.O. **3528**

12/16/03

Raypak

WIRING DIAGRAM IID REMOTE SPA FIRING MODE — ON/OFF

INPUTS: 512,000 THRU 726,000 BTUH

SIZE: **514-724** TYPE: **P**

152141 **9**

Wiring Diagram—Model 824—Spa

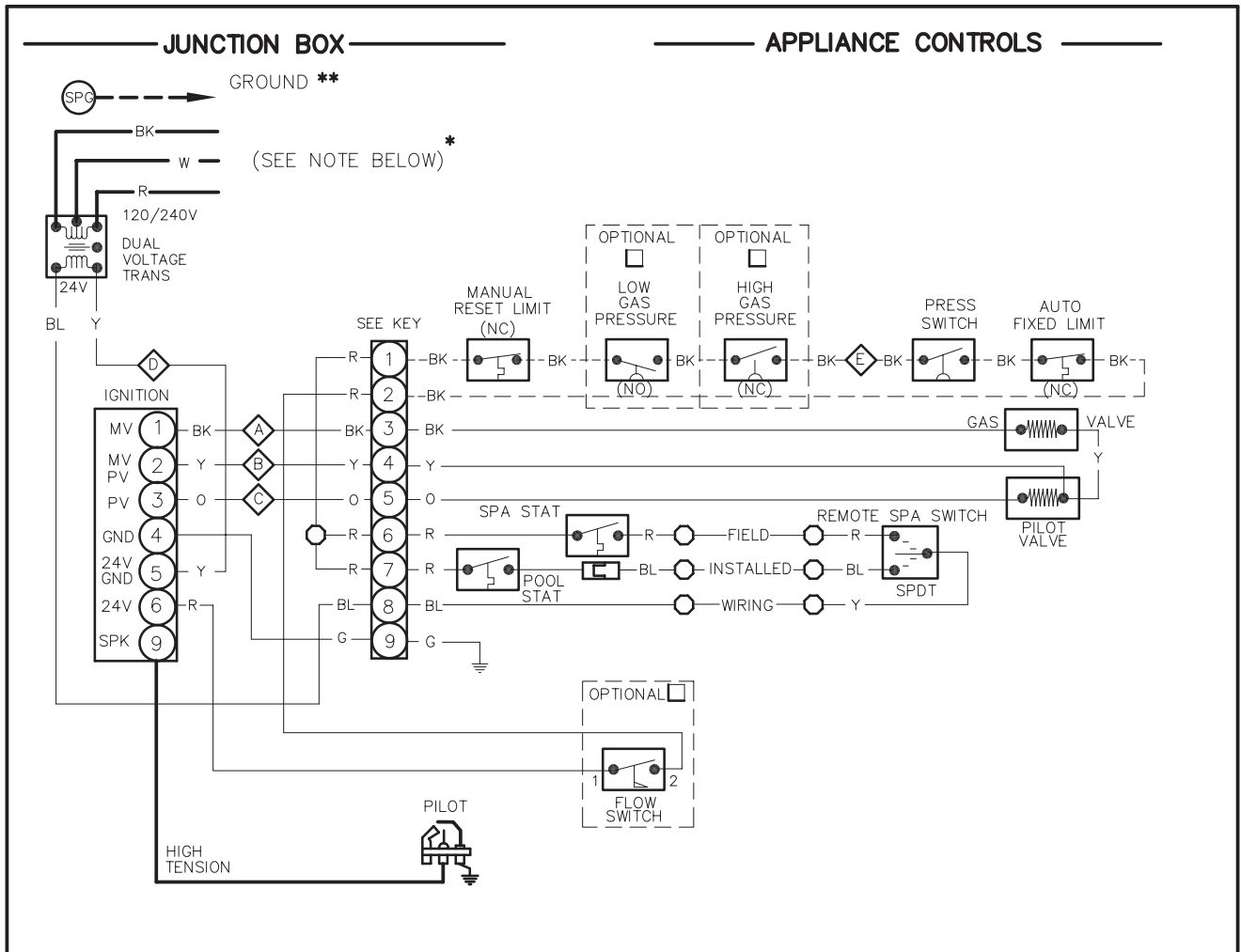

*** TRANSFORMER WIRING INFO**

—BK— L1 → 240V HOT
 —W— L2 → 240V COMM
 —R— L2

—BK— L1 → 120V HOT
 —W— L2 → 120V COMM
 —R— L2

APPROVED BY:
 CHECKED BY:
 ORIG E.O. **2096**
01/03/86
 CHG E.O. **3528**
12/17/03

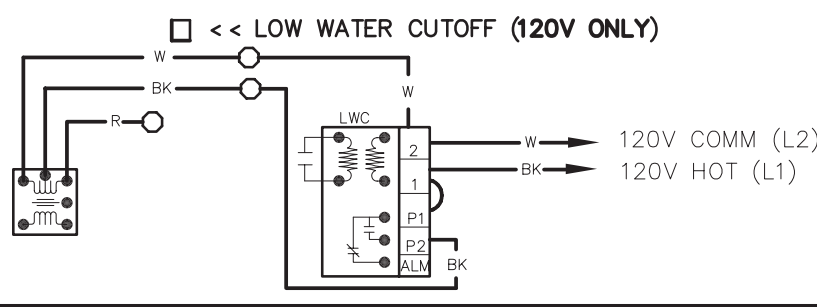

NOTES:

****** USE GROUND CONNECTION PROVIDED. FAILURE TO PROVIDE PROPER GROUND MAY RESULT IN LOCK-OUT. ALL GROUND \perp TERMINATE AT SPG .

A — **E** CONNECTIONS FOR OPTIONAL E-4 ALARM PANEL.

CHECK CONTROLS PROVIDED (WIRED AS SHOWN)
 REPLACE WIRING WITH 105°C WIRE ONLY

WIRING DIAGRAM IID REMOTE SPA FIRING MODE — ON/OFF

INPUTS: 825,000 BTUH
 SIZE: **824** TYPE: **P**

KEY

— 24V
 — 120V
 - - - 150°C

SPG GROUND
 ○ WIRE NUT

BK — BLACK
 BL — BLUE
 BR — BROWN
 G — GREEN
 O — ORANGE
 R — RED
 V — VIOLET
 W — WHITE
 Y — YELLOW

PLUG (ACTUAL)

3	2	1
6	5	4
9	8	7

FRONT VIEW

152142 **10**

Servicing

General Location of Controls

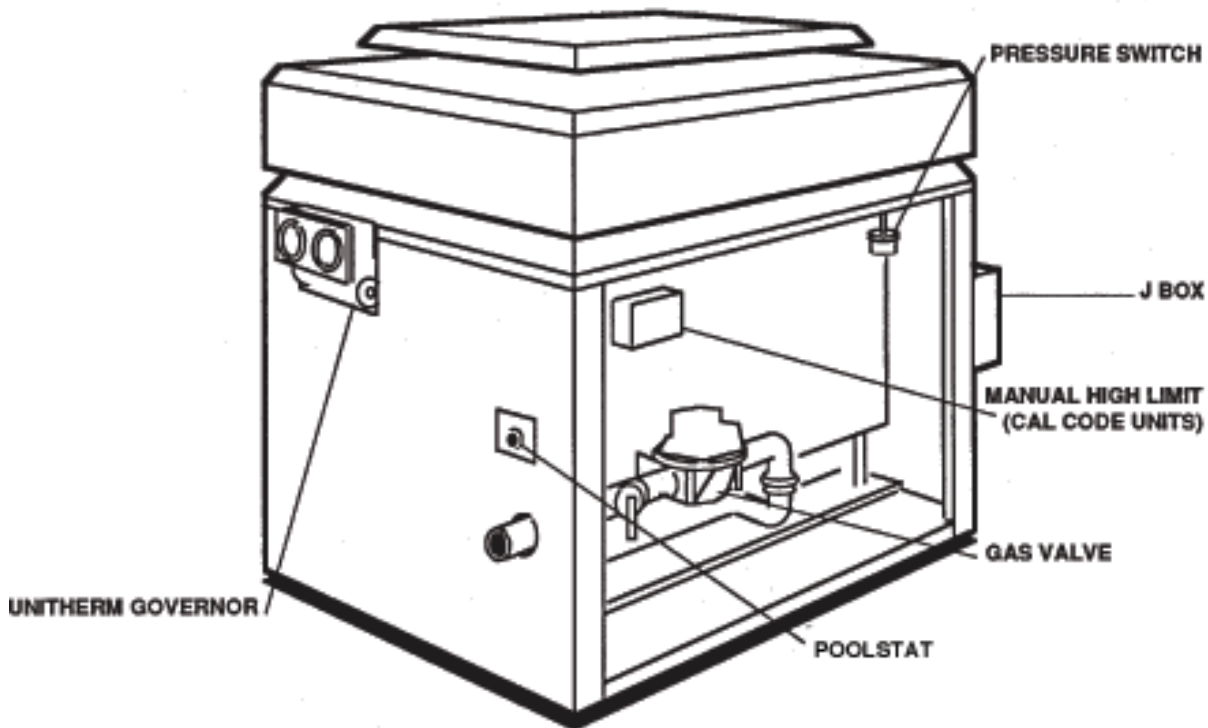

Fig. 19: General Location of Controls

Controls/Adjustments/Replacements

Poolstat

The heater is built with a single mechanical poolstat, located in the front panel above the door. The poolstat may be set for any desired pool or spa temperature from 66-104°F.

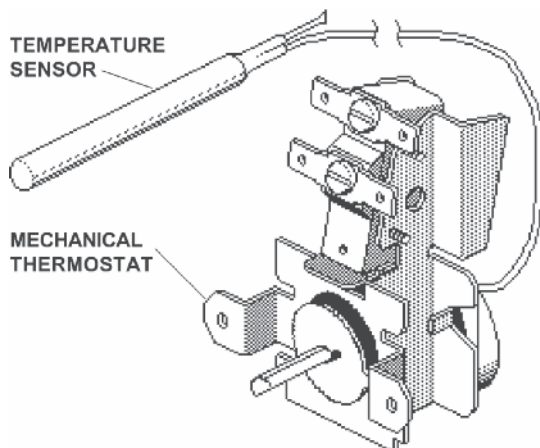

Fig. 20: Poolstat

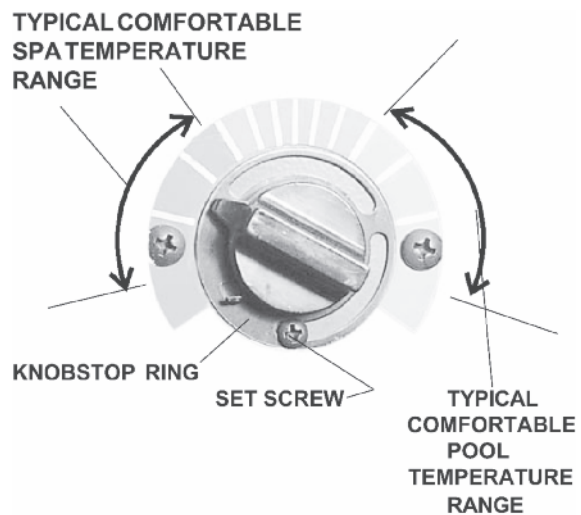

Fig. 21: Knobstop

Knobstop Adjustment

If desired, a higher setting of the poolstat can be obtained by adjusting the knobstop ring on the dial plate. Loosen the set screw, adjust the knobstop for the higher desired temperature setting and retighten the set screw.

Pressure Switch

The pressure switch, or heater actuator, ensures that the heater operates only when the filter pump is in operation. It is factory set at 1.75 PSI for deck level installations. When the heater is located below the level of the spa or pool it may be necessary to reset the pressure switch to compensate for the no-flow static head. If it is necessary to reset the pressure switch, we recommend the following procedure.

Pressure Switch Adjustment

1. Make sure the pool filter is clean before adjusting the switch.
2. Set the heater control to the OFF mode.
3. Turn the filter pump on and confirm that the pressure switch is closed (use a multimeter to check). If the pressure switch fails to close, either the switch setting is too high or the filter pump is not supplying enough pressure.
4. Turn the heater ON.
5. Manually turn the pressure adjustment knob clockwise until the heater shuts off. (A flat screw driver may be necessary if knob is too tight).
6. Slowly turn the adjustment knob counter-clockwise until the heater calls for heat again.
7. Turn an additional 1/2 turn counter-clockwise.
8. While the heater is running, check the adjustment by turning the pump off and on several times. The burners should shut off immediately when the pump is turned off. If it does not, repeat the above steps until proper operation is observed.

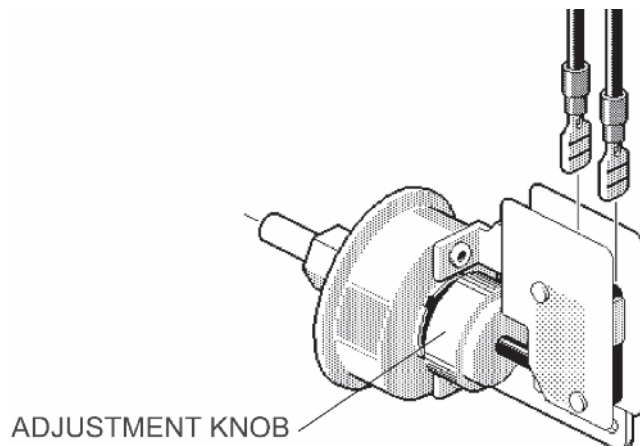

Fig. 22: Pressure Switch Adjustment Range

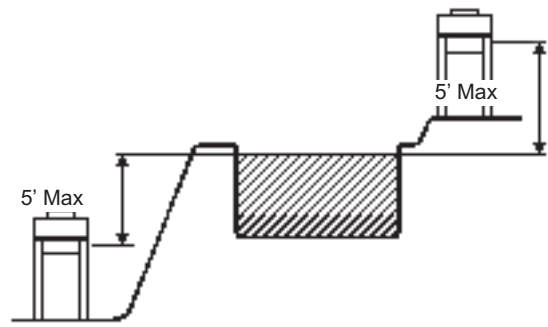

Fig. 23: Heat Exchanger Height Above/Below Pool

NOTE: If heater is installed outside of the limits shown in Fig. 23, a flow switch must be used in place of the pressure switch when mounted and wired adjacent to the heater.

Two-Speed Pumps

In some cases, the flow on the low speed is insufficient to operate the heater. This is apparent when the pressure switch cannot be further adjusted or if the heater makes banging noises. In these cases, the pump must be run at high speed when heating the water.

CAUTION: Do not operate the heater without a functioning and properly adjusted pressure switch.

High Limits

The heater is equipped with two automatic high limits. Set to operate at 135°F and 140°F.

NOTE: An erratic high limit is often characteristic of an internal heat exchanger problem, i.e. scale build-up, U.G. operation. Refer to troubleshooting sections.



Fig. 24: High Limit

High Limit Removal

1. Shut off main electrical power switch to heater.
2. Remove inspection panels.
3. Drain heater.
4. Remove defective high limit and replace with a new high limit.
5. Reverse above procedure to re-install.

Pilot Safety

The heater employs a pilot safety which closes the main gas valve within 8/10ths of a second whenever the pilot flame is interrupted. Pilot flame is automatically lit when the device is powered. Unit performs its own safety check and opens the main valve only after the pilot is proven to be lit.

Burner Drawer Removal

1. Shut off main electrical power switch to heater.
2. Shut off gas upstream of heater.
3. Remove front door.
4. Disconnect gas line from gas valve.
5. Remove (2) screws that mount burner tray to unit, and (2) screws that secure gas valve to jacket.
6. Disconnect wires that terminate at gas valve.
7. Slide out burner tray.
8. Reverse above procedure to reinstall.

Gas Valve Removal

1. Shut off gas supply to the heater. Remove gas piping to gas valve inlet.
2. Disconnect wires, pilot tubing and bleed line, if required.
3. Turn vertical gas pipe from manifold slightly and unscrew gas valve.
4. Reverse above procedure to re-install.

Main Burner and Orifice Removal

1. Remove burner drawer. See burner drawer removal procedure.
2. Remove screws and burner hold down bracket.

NOTE: If the heat exchanger is sooted badly, the burner hold-down bracket and spacer can become distorted from direct flame impingement; this usually necessitates replacement of these parts.

3. Lift burners from slotted spacers and slide from orifices. Clean with a non-sparking wire brush.
4. Orifices usually do not need to be replaced. To clean, run either copper wire or wood toothpick through orifice. Do not enlarge hole. To remove orifice, use a socket wrench and remove from manifold. DO NOT over tighten when reinstalling.

Pilot Removal and Cleaning

1. Remove burner drawer. (See burner drawer removal procedure).
2. Disconnect pilot tubing, disconnect wires from gas valve.
3. Disconnect pilot bracket from burner shield.
4. Remove pilot from bracket.
5. Remove pilot orifice and air opening, and clean with wire or small brush. CAUTION! DO NOT enlarge hole in pilot orifice.
6. Reverse above procedure to re-install.

Heat Exchanger Removal

1. Shut water, gas and electricity off, close valves and relieve pressure, remove relief valve. Remove side inspections panels.
2. Remove top holding screws.
3. Remove draft diverter, lift and remove top and flue collector. Remove inspection panels.
4. Loosen bolts and disconnect flange nuts on inlet-outlet header, loosen union(s) at gas pipe and slide heater away from piping until stud clear the header.

RAYPAKTUBE CLEANING KIT

Extension Pieces (5)

Auger with Carbide Tip

Wire Brush

Fig. 34: Tube Cleaning Kit

5. Remove heat exchanger corner brackets.
6. Remove combustion chamber clips at the four corners of the heat exchanger.
7. Lift heat exchanger straight up using caution not to damage refractory.
8. Reverse above procedure to reinstall.

Tube Cleaning Procedure

Establish a regular inspection schedule frequency, depending on local water condition and severity of service. Do not let the tubes clog up solidly. Clean out deposits over 1/16" in thickness.

The heater may be cleaned from the right side, without breaking pipe connections. It is preferable, however, to remove both headers for better visibility through the tubes and to be sure the ground-up lime dust does not get into the system.

Note that you do not remove the top panel or the heat exchanger, generally. After reaming, mount the wire brush in place of the auger and clean out debris remaining in the tubes.

Another method is to remove the heat exchanger, ream tubes and immerse heat exchanger in non-inhibited de-scale solvent for severe scale buildup.

Tube Replacement Procedure

On Raypak units, tube replacement may be effected without rolling as a temporary means or repair, providing there are two or more tubes rolled in to act as stays on the left and right side. The "O" rings should provide a seal up to 120 PSI working pressure.

Use 3/8" heavy-duty reversible drill motor or larger to power the tube roller. If a reversible drill is not available, after rolling the tube in, remove the drill motor and wrench out the roller. A tube roller is available from the factory.

Shut gas and power off to the unit, close the system off and drain the heater. Remove the draft diverter. Remove the access panel and jacket top. Lift flue collector off. Remove "V" baffles over tube(s) to be replaced. If no pipe unions have been provided, use the header as a union, remove the flange nuts off the inlet/outlet header, break gas connection and slide heater away from piping to allow room to work. Pull wedge clips out of control wells and remove sensing bulbs. Remove flange nuts of the return header and remove header. Lift heat exchanger straight up and out.

Heat exchanger header o-rings must be replaced with new ones. The tube may be cut out with a hacksaw or hammer and chisel adjacent to both tube sheets, leaving studs in the tube sheets. Then proceed to collapse studs in the tube sheets with a chisel or screwdriver. Use caution not to cut into the tube sheet. Replacement tubes will have the fins stripped off longer on one end. The long end is inserted into the opening of the tube sheet first; then the short end is fitted through the opposite tube sheet. If the tube ends become dented or bent, straighten at least (4) inches back from the tube and by means of a tapered punch.

Insert tube roller into tube opening up to stop against tube, then push center rod in until roller is tight. Be careful to keep replacement tube squared up 1/8" outside each tube sheet. A loose tube will sometimes pull toward the roller. Attach drill motor to tube roller, holding it straight and level. Proceed to expand tube until the tool begins to grab. At this point, 1/2" to 1" should be expose on the tool shank. Reverse drill motor or wrench out by hand. Care should be exercised to avoid applying excessive torque during rolling operation and to avoid thinning out any part of the tube wall excessively over .015". Use same procedure at the opposite end of the tube.

Apply line pressure test, and re-roll, if necessary, before reassembly of the heater.

De-sooting Procedure

CAUTION: Soot is combustible. exercise extreme care.

Soot will clog areas between fins and cause eventual tube failure. Any sign of soot at the base of the burners or around the outer jacket indicates a need for cleaning.

1. Remove top and flue collector from cabinet.
2. Remove "V" baffles from heat exchanger.
3. Remove burner drawer. (See burner tray removal).
4. Take garden hose and wash heat exchanger, making sure soot is removed from between fins. (Avoid excessive water against refractory).
5. Reassemble. When heater is fired, some steam will form from wet refractory. This is normal.

NOTE: In extreme cases it may be necessary to remove the heat exchanger completely for cleaning. The simplest method is steam cleaning at the local car wash. DO NOT WIRE BRUSH.

Combustion Chamber Removal

To remove the combustion chamber, you must first have removed the heat exchanger. Unbolt metal combination chamber retainer from top and remove combustion chamber panels individually.

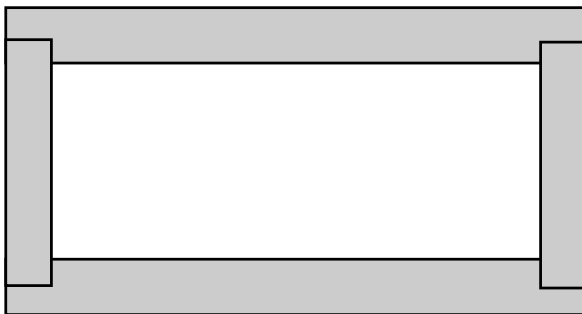

Fig. 35: Refractory Panels—Top View

Control Immersion Well Replacement

Remove top, sensing bulb and clip. Collapse well tube at the open end with a chisel, push through into header and remove the header. Insert a new well and roll into place. If a roller is not available, solder or braze.

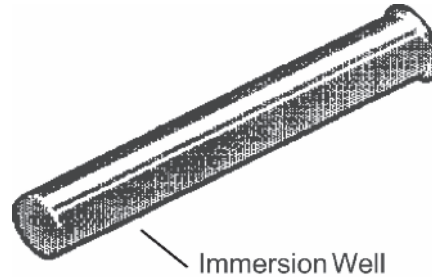

Fig. 36: Immersion Well

Unitherm Governor (U.G.) Replacement

1. Shut water, gas and electricity off, close valves and relieve pressure.
2. Drain heat exchanger.
3. Loosen and remove (2) bolts that secure U.G. Assembly to header.
4. Remove U.G. Assembly with gasket.
5. Reverse above procedure to re-install.



Fig. 37: Location of U.G.

To test the operation of the Unitherm Governor, place in hot water (over 100°F) and watch for movement against spring. If there is not movement, replace unit.

Troubleshooting

IMPORTANT NOTICE

These instructions are primarily intended for the use of qualified personnel specifically trained and experienced in the installation of this type of heating equipment and related system components. Installation and service personnel may be required by some states to be licensed. Persons not qualified shall not attempt to install this equipment nor attempt repairs according to these instructions.

MECHANICAL (FOR QUALIFIED SERVICE PERSONNEL ONLY)

PROBLEM	CAUSE	SOLUTION
Harmonics, or whining noise.	U.G. inoperative.....	Check movement by putting in hot water (110°F or higher). If no movement, replace.
	* Debris or restriction in system.....	Locate the restriction and remove. Flush system and clean.
	* Debris in gas line.....	Remove debris or blow out gas line.
	Low flow.....	Scale forming in heat exchanger-clean heat exchanger and check pool pH and total alkalinity.
Heater going on and off continuously.	Dirty filter.....	Backwash filter.
	Low water level in pool.....	Raise water level.
	External bypass setting out of adjustment.....	Adjust bypass
	* Pressure switch out of adjustment.....	Adjust pressure switch
Liming or scale forming on heat exchanger.	Pool water.....	See Water Chemistry page 2.
Sooting	High flow rates.....	Reduce by adding manual bypass valve and adjust by putting thermometer in header (1/4" NPT) drain opening. Set bypass so thermometer reads between 105° and 110°F.
	U.G. Inoperative.....	Check movement by putting in hot water (110° or higher). If no movement, replace.
	* Air starvation.....	Refer to installation instructions.
	* Improper venting.....	Follow recommended installation instructions.
	* Insects or debris clogging burner intake ports.....	Clean burners.
Pilot outage.	Low gas pressure.....	Adjust gas pressure.
	Restricted pilot.....	Clean pilot.
	Weak pilot generator.....	Replace pilot.
Yellow lazy flame	Low gas pressure.....	Adjust gas pressure.
	* Insects or debris clogging burner intake ports.....	Clean burners.
Outer jacket very hot (paint blistered)	* Broken refractory caused by shipping damage or improper combustion.....	Replace refractory panels.
Takes long time to heat pool or spa.	Excessive sooting of heat exchanger.....	Determine cause of sooting & correct.
	Calculate temperature in °/hr.....	Heat rise (°/hr.) = Heater output ÷ (Pool gallonage x 8.33) or refer to heater sizing chart.
		This does not take into account heat loss due to weather.
		Reset time clock.
	Filter not running long enough.....	Clean filter.
	Dirty filter.....	Refer to installation instructions.
	Gas line or meter undersized.....	

(*Usually occurs on initial start-up)

Liming	Bypassing too much water.....	Inspect bypass for movement, if no movement, replace.
	U. G. not functioning.....	Replace if no movement when heated.
Leaking at well. Leaking at heat exchanger.	Overacid.....	Replace well and maintain water chemistry properly.
Gasket brittle and leaking (overheated).	Overacid.....	Replace heat exchanger and maintain chemistry properly.
	Heater running after pump shuts off.....	See pressure switch adjustment.
	Refractory damage.....	Replace refractory.
	Sooted heater.....	Determine cause of sooting and correct.

ELECTRICAL

WARNING: HIGH VOLTAGE. For qualified technicians **ONLY**.

NOTE: Some heaters may be equipped with an ignition module that shuts off pilot gas if the pilot fails to light. To reset, interrupt power to the heater.

**Intermittent Pilot System
TROUBLESHOOTING HONEYWELL S8600 IGNITION MODULE**

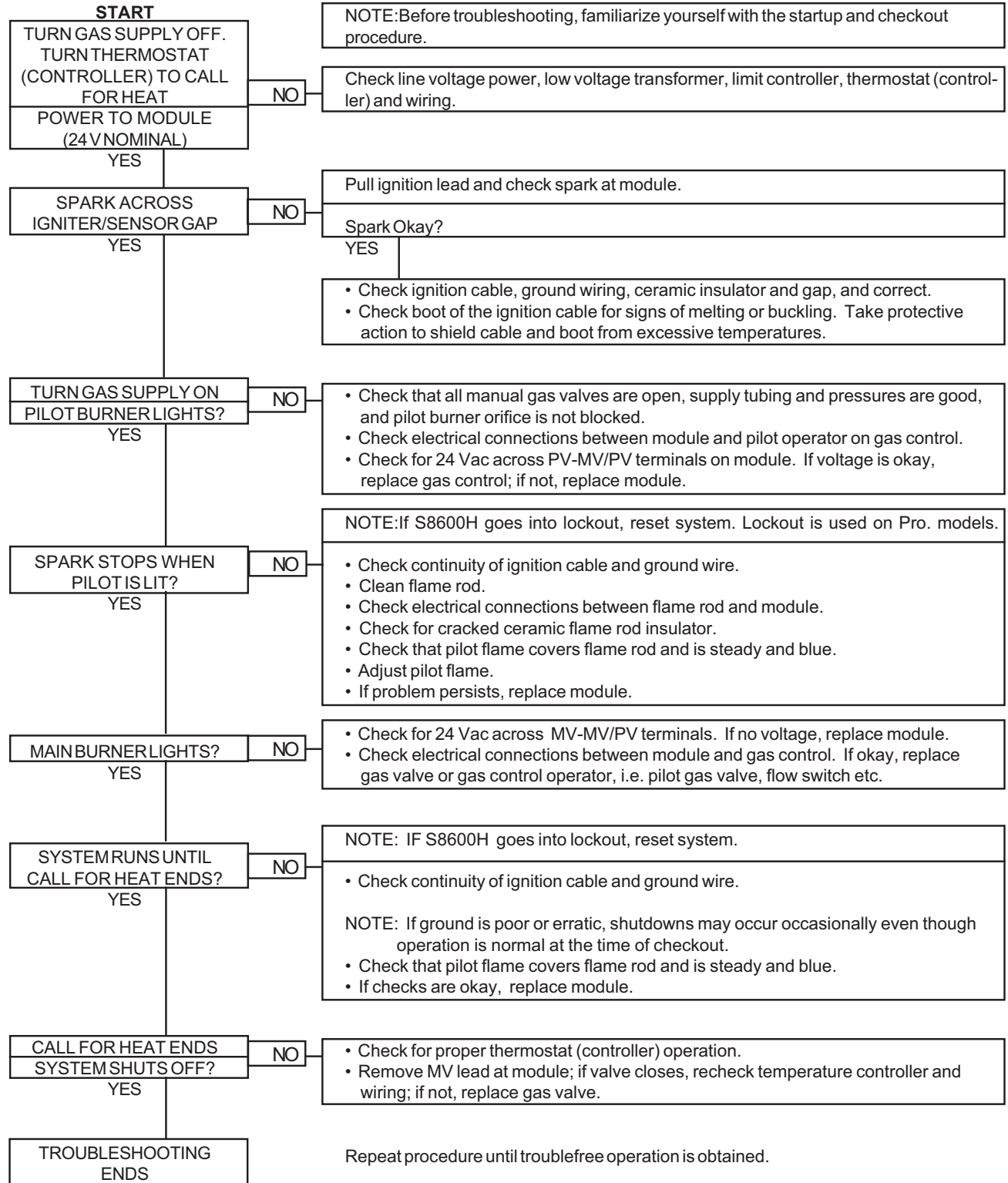

Replacement Parts

NOTE: To supply the correct part it is important that you state the model number, serial number and type of gas when applicable.

Any part returned for replacement under standard company warranties must be properly tagged with RAYPAK return parts tag, completely filled in with the heater serial number, model number, etc., and shipped to the Company freight prepaid.

If determined defective by the Company and within warranty, the part will be returned in kind or equal substitution, freight collect. Credit will not be issued.

Raypak, Inc.
2151 Eastman Avenue
Oxnard, CA 93030

Replacement parts for the 514-824 Raytherm Swimming Pool Heaters may be found in Raypak's Illustrated Parts List, Catalog No. **9100.60**, which is available at the Raypak website:

<http://www.raypak.com/>



www.raypak.com

Raypak, Inc., 2151 Eastman Avenue, Oxnard, CA 93030 (805) 278-5300 Fax (805) 278-5468
Litho in U.S.A.