

INSTALLATION AND OPERATION MANUAL

VERSA IC[®] INTEGRATED BOILER CONTROL

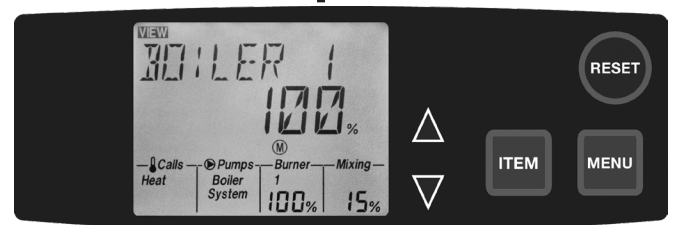

THIS INSTALLATION MANUAL CAN BE VIEWED ELECTRONICALLY USING YOUR SMART DEVICE. SEE PAGE 84 FOR QR CODE.

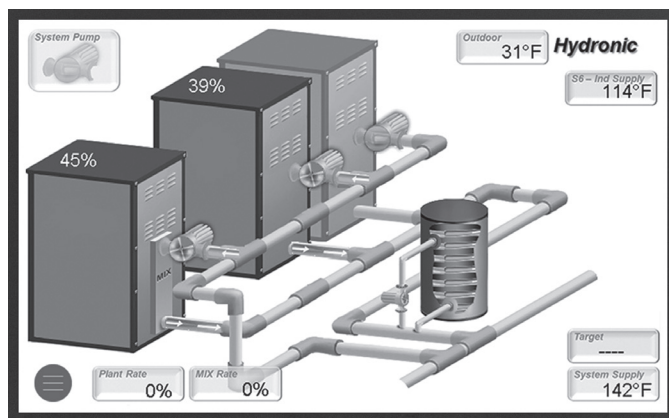

TABLE OF CONTENTS

1. WARNINGS	4	Exchanger (IND SUPPLY)	44
1.1. Pay Attention to These Terms	4	6.17. Selection of Indirect Priority (IND PRIORITY)	44
2. VERSA IC BOILER CONTROL	5	6.18. Priority Override Time (PRI OVR)	44
2.1. Introduction	5	6.19. Cold Water Protection (CWP)	44
2.2. VERSA Control Board	5	6.20. MIX Type	44
2.3. VERSA Display Board (If equipped)	6	6.21. MIX Target	44
2.4. Touchscreen Display (If equipped)	7	6.22. MIX Lock	44
2.5. VERSA PIM Module	10	6.23. MIX Speed	44
3. QUICK START SET-UP	11	6.24. MIX Inv	44
3.1. System Sensor Installation	11	6.25. MIX Trim	45
4. APPLICATIONS AND MODES	12	6.26. H Models & MIX Type = PUMP	45
4.1. Boiler Applications	12	6.27. Temperature Units of Measure (°F or °C)	45
4.2. Mode 1 - Hydronic Systems without Indirect DHW - Primary/Secondary	12	6.28. Glycol Selection	45
4.3. Mode 2 - Hydronic Systems with Indirect DHW - Primary/Secondary	18	6.29. Modbus Operating Mode Selection (MODBUS)	45
4.4. Mode 3 - Hydronic Systems with Indirect ..	23	6.30. Modbus Component Address	45
4.5. Mode 3 Single	24	6.31. Vent Protection	45
4.6. Primary Piping Configuration - XVers	29	6.32. Modbus Data Type (DATA TYPE)	46
4.7. WH Direct DHW Applications	29	6.33. Modbus Communication Baud Rate (BAUD RATE)	46
4.8. WH - Cascade	30	6.34. Modbus Parity (PARITY)	46
4.9. Pool – Heater Applications	34	6.35. Heater Mass (BOIL MASS)	46
5. VERSA IC MENUS	38	6.36. Boiler Pump Purge (BOIL PURGE)	46
5.1. User Interface Menus	38	7. ADDITIONAL OPERATIONAL FEATURES	46
5.2. VIEW Menu	38	7.1. Outdoor Reset Operation	46
6. CONTROL SETTINGS	42	7.2. Reset Ratio/Outdoor Reset	47
6.1. Boiler System (BOILER 1, 2, 3, 4)	42	7.3. Warm Weather Shut Down (WWSD)	47
6.2. Outlet Max	42	7.4. Reset Ratio	47
6.3. Minimum Modulation Setting	42	7.5. Pump and CWP Exercise	48
6.4. Target Configuration (TARGET)	42	7.6. Freeze Protection	48
6.5. Mode Selection (MODE)	42	7.7. Heater Rotation	48
6.6. Setpoint Temperature (SETPOINT)	42	7.8. Target Differential – Auto/Manual	48
6.7. Tank Setpoint (TANK SETP)	42	7.9. Minimum Run Time	48
6.8. Pool Setpoint (POOL SETP)	42	7.10. Outdoor Sensor Fault Operation	48
6.9. Pool Maximum Supply (SUPPLY MAX)	43	7.11. System Sensor Fault Operation	48
6.10. Differential Settings	43	7.12. Field Test	49
6.11. System Pump Purge (SYS PURGE)	43	7.13. LED: User Test	49
6.12. Maximum Target Boiler Temperature (TARGET MAX)	43	7.14. Touchscreen: User Test	49
6.13. Minimum Target Boiler Temperature (TARGET MIN)	43	7.15. Commission Test Mode (Hi-Limit Test)	50
6.14. Indirect Sensor Selection (IND SENSOR) ..	43	7.16. Max Heat Function	50
6.15. Target Indirect DHW Temperature (IND SETP)	43	7.17. Max Delta-T Protection	50
6.16. Target Boiler Temperature for DHW Heat		8. SEQUENCE OF OPERATION	50
		9. WIRING CONNECTIONS - PIM	52

9.1. PIM Low-Voltage Connections.....	53	13. TROUBLESHOOTING	66
9.2. PIM Factory Low-Voltage Wiring Connections.....	54	14. TECHNICAL DATA	71
9.3. Wiring Connections – VERSA IC System..	55	15. ADDITIONAL TROUBLESHOOTING	72
9.4. Wiring the Thermostat	55	15.1. 10K Sensor Resistance Values	72
9.5. Wiring the Outdoor Sensor (S4)	55	15.2. Restoring VERSA IC to Factory Defaults	72
9.6. Wiring the Indirect Sensor (S5)	55	15.3. Resetting PIM	72
9.7. Parallel Pump Wiring Description	56	15.4. Flow Sensor Calibration	72
9.8. External Interlock.....	57	15.5. Touchscreen Reboot.....	73
10. ENERGY MANAGEMENT SYSTEM SETUP	57	16. MODBUS PROTOCOL.....	73
10.1. Control Signal	57	16.1. Modbus Messaging	74
11. CASCADE SET-UP AND OPERATION.....	58	17. QR CODES	84
11.1. Cascade Features	59		
11.2. Cascade Staging Selection	59		
11.3. Wiring the Cascade System Communication Bus	60		
11.4. Cascade Topology	61		
12. “LIMP-ALONG” OPERATION OF PIM	66		
12.1. Limitations During PIM “Limp-Along” Operation.....	66		

Revision 15 reflects the following changes: Added "XVers with KOR" reference throughout all sections that mention supported models; Updated Figure 52. Table AH: Updated description callouts for more clarity; Table AE: Added "X 10" to Note. Table AH: Added new error 69 (Flame Loss Warning); Added QR Code section.

1. WARNINGS

1.1. Pay Attention to These Terms

▲ DANGER	Indicates the presence of immediate hazards which will cause severe personal injury, death or substantial property damage if ignored.
▲ WARNING	Indicates the presence of hazards or unsafe practices which could cause severe personal injury, death or substantial property damage if ignored.
▲ CAUTION	Indicates the presence of hazards or unsafe practices which could cause minor personal injury or product or property damage if ignored.
CAUTION	CAUTION used without the warning alert symbol indicates a potentially hazardous condition which could cause minor personal injury or product or property damage if ignored.
NOTE	Indicates special instructions on installation, operation, or maintenance which are important but not related to personal injury hazards.

▲ DANGER: Make sure the gas on which the boiler/heater will operate is the same type as that specified on the boiler/heater rating plate.

▲ WARNING: Boilers/Heaters using propane gas are different from natural gas models. A natural gas boiler will not function safely on propane and vice versa. Conversions of boiler/heater gas type should only be made by qualified installers using factory-supplied components. The boiler/heater should only use the fuel type in accordance with listing on rating plate. Any other fuel usage will result in death or serious personal injury from fire and/or explosion.

▲ WARNING: Should overheating occur or the gas supply valve fail to shut, do not turn off or disconnect the electrical supply to the boiler/heater. Instead, shut-off the gas supply at a location external to the boiler/heater.

▲ WARNING: Do not use this boiler if any part has been under water. Immediately call a qualified service technician to inspect the boiler/heater and to replace any part of the control system and any gas control which has been under water.

▲ WARNING: To minimize the possibility of improper operation, serious personal injury, fire, or damage to the boiler/heater:

- Always keep the area around the boiler/heater free of combustible materials, gasoline, and other flammable liquids and vapors.
- Boiler/heater should never be covered or have any blockage to the flow of fresh air to the boiler/heater.

▲ WARNING: Risk of electrical shock. More than one disconnect switch may be required to de-energize the equipment before servicing.

▲ WARNING: When servicing or replacing any components of the control system within this unit, be certain that:

- The gas is off.
- All electrical power is disconnected.

▲ WARNING: Improper installation, adjustment, alteration, service, or maintenance can cause property damage, personal injury or loss of life. Refer to the user's information manual provided with the boiler/heater. Installation and service must be performed by a qualified installer, service agency, or the gas supplier.

▲ WARNING: Both natural gas and propane have an odorant added to aid in detecting a gas leak. Some people may not physically be able to smell or recognize this odorant. If you are unsure or unfamiliar with the smell of natural gas or propane, ask your local gas supplier. Other conditions, such as "odorant fade," which causes the odorant to diminish in intensity, can also hide, camouflage, or otherwise make detecting a gas leak by smell more difficult.

2. VERSA IC BOILER CONTROL

2.1. Introduction

The VERSA IC is an appliance-integrated control system consisting of the following components:

- VERSA Control Board
- VERSA Display Board or Touchscreen
- VERSA Platform Ignition Module (PIM) in HSI, DSI or Supervised Pilot Ignition
- ID Card
- Water Sensors (up to 5)
- Vent Sensor
- Outdoor Air Sensor

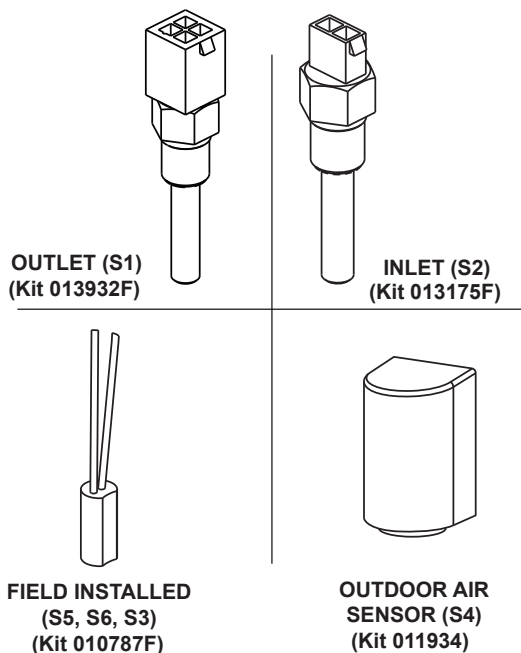

Figure 1. Water Sensors

The VERSA IC system provides integrated functions of automatic ignition control, thermostat control, high temperature limit control, diagnostic enumeration, safety interlock, domestic hot water (DHW) override, cold water protection (CWP), and several options for external heater control for commercial boilers, water heaters, and pool heaters.

The VERSA IC system controls the heater pump, system pump, and indirect DHW pump simultaneously, as needed. In addition, the VERSA IC system allows cascading control of multiple units, up to 8 units total, without the need for an external sequencer. The VERSA IC system is Modbus ready for easy external communication and control.

2.2. VERSA Control Board

The VERSA Control Board provides high-level functionality for the VERSA IC system. See **Figure 2**. It has field interlock connections, cascading heater connections, and VERSA Display Board connections.

The VERSA IC system allows “limp-along” operation via the PIM if the VERSA Control Board becomes inactive or if the communications between the VERSA Control Board and the PIM are terminated for any reason. See **“LIMP-ALONG” OPERATION OF PIM** on page 66. The VERSA Control Board is ANSI Z21.23 certified as a boiler/water heater controller and as a pool controller.

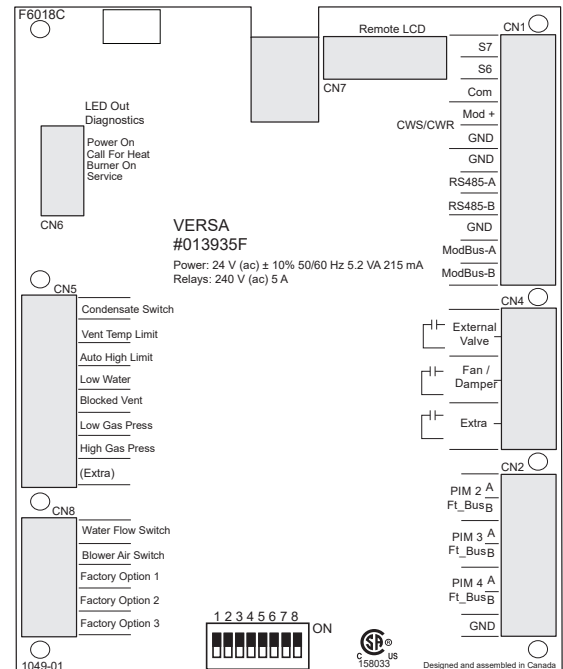

Figure 2. Versa Control Board

The VERSA Control Board includes connections for:

LED Indicator Lights (model specific):

CN6

- Green – POWER ON
- Amber – CALL-FOR-HEAT
- Blue – BURNER ON
- Red – SERVICE REQUIRED

Diagnostic Inputs:

CN5

- Condensate Switch
- Vent Temperature Limit
- Auto High Limit
- Low Water Cutoff
- Blocked Vent
- Low Gas Pressure
- High Gas Pressure
- Extra – (future usage)

CN8

- Water Flow Switch
- Blower Air Switch (model specific)
- Factory Option 1 – Factory Defined (10-second delay)
- Factory Option 2 – Factory Defined (30-second delay)
- Factory Option 3 – Factory Defined (90-second delay)

Cascade Communication Connections:

(Ft_bus Communication)

NOTE: For PIM 5 through PIM 8 see Section 11.0.

CN2

- PIM 2 – A & B
- PIM 3 – A & B
- PIM 4 – A & B

External Device Triggers (Dry Contact):

CN4

- External Valve
- Fan/Damper
- Extra - status (burner)

Auxiliary Sensor Inputs:

CN1

- S6 – IND Supply Sensor/Pool Return Sensor
- S7 – N/A

0-10 VDC Output (Cold Water Protection)

- Mod+/-

Communication Connections

- RS485 (Touchscreen)
- Modbus RS485 (RTU/ASCII)

VERSA Display Connection (Ribbon Cable)

VERSA PIM Connection (RJ45 Connection)

DIP Switches. See Figure 3.

- #1 – Access Level
 - **OFF – Installer**
 - ON - Advanced
- #2 – Cascading
 - **OFF – Follower/Slave**
 - ON – Master
- #3 – Cold Water Protection (CWP)
 - **OFF – None**
 - ON – CWS/CWR
- #4 – Proportional Output Selection
 - **OFF – 0-10 VDC**
 - ON – 0-20mA (requires 500 ohm resistor)

- #5 – N/A
- #6 – Heater Rotation (see page 48)
 - **OFF – No Rotation**
 - ON – Enable Rotation
- #7 – Indirect Pool Products Only
- #8 – N/A



Figure 3. VERSA Control Board DIP Switches for Master Defaults

2.3. VERSA Display Board (If equipped)

The VERSA Display Board is the board with the LCD display viewable from outside of the heater. See Figure 4. All operation and settings of the VERSA IC are accomplished through the use of the 5 buttons of the user interface. These buttons are labeled as follows:

- **MENU – Scroll through available menus**
- **ITEM – Scroll items within the selected menu**
- **UP – Increase values in the Adjust menu**
- **DOWN – Decrease values in the Adjust menu**
- **RESET – Clear lockout**

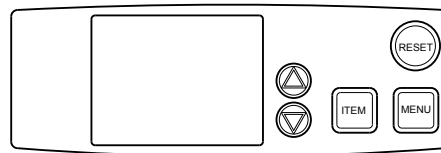

Figure 4. VERSA Display Board

The display uses a Liquid Crystal Display (LCD) as the method for supplying information. Use the LCD to setup and monitor the operation of your heater. See Figure 5.

When powering up the unit for the first time or recovering from a power cycle, the LCD will show a LOADING banner for approximately 10-seconds. During this period of time the board performs a self-check routine to ensure the control boards have proper parameters. If the membrane switch remains inactive for 180-seconds (3-minutes), the screen will revert to the VIEW menu – Boil INLET unless some error/fault exists – then the fault will be displayed. Touching any button resets this timer (the timer can be seen in the bottom right corner of the display) to keep the current view.

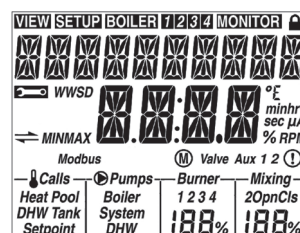

Figure 5. Liquid Crystal Display (LCD)

The VERSA Control Board has two access levels: Installer and Advanced. Most settings are hidden in the Installer mode. The Advanced mode can be accessed by changing the VERSA DIP switch #1 from the OFF position (Installer) to the ON position (Advanced).

⚠ WARNING: Return the VERSA Control Board DIP switch #1 to the OFF (Installer) position after heaters are fully set up and commissioned, to prevent inadvertent changes to program settings by unauthorized personnel.

The default menu displayed is the VIEW menu. If there is an unresolved (active) error, then the default menu is the TOOLBOX menu. The default item will be the active error message. After 180-seconds of keypad inactivity, the VERSA Display will return to the default menu and display the default item.

2.4. Touchscreen Display (If equipped)

The touchscreen user interface uses a high-definition capacitive screen. See **Figure 6**. It includes an extensive graphical library used to represent different pipe configurations, error locations, and operation of the unit. The touchscreen has the same basic menu distribution as the original LCD Display. When pressing the menu button the menu bar becomes visible at the bottom of the screen allowing navigation through six additional submenus (VIEW, ADJUST, BOILER, DOCUMENT VIEWER, TOOLS, and Wi-Fi).

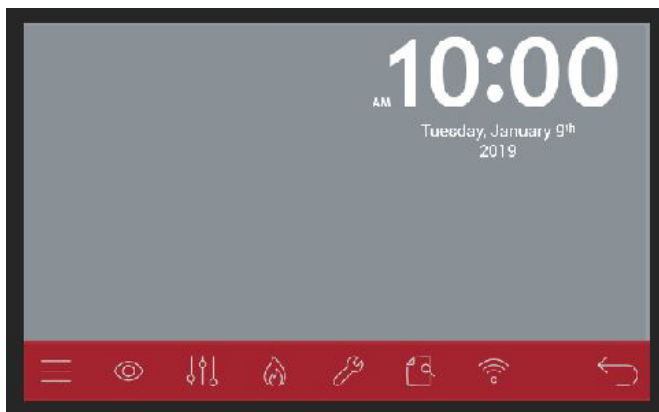

Figure 6. User Interface

In addition to the traditional LCD display, the touchscreen offers a few extra features, such as:

- Date/Time stamp
- Diagnostics file
- Editable contact information
- Touchscreen adjustable parameters such as time-out, dim-out, and brightness

To have a better understanding of the menu items and screen distribution, see **Figure 8** and **Table A**.

2.4.1. DATE/TIME STAMP

A real-time clock is built into the touchscreen to provide and hold a date and time stamp.

In normal operation the battery is only used during the off time periods. This is to prevent the time stamp from being formatted. The expected lifetime of the battery is between 1 to 1.5 years with a constant current draw of 0.03mA. Although time is configured during the factory verification process, it is recommended for the final user to confirm the right time setting.

2.4.2. DIAGNOSTICS FILE

Within the TOOL menu under system category, there is a button labeled as FACTORY DIAGNOSTIC. See **Figure 7**. This function will enable a recording process (5-second sampling rate) that will result in a set of files stored in the SD card provided with the touchscreen.

When an evaluation of the overall performance of the unit is required, these files can be sent to the factory for verification.

The file creation process can be aborted manually by disabling the process, or it can expire automatically after the time period defined by the user (adjustable in the same screen).

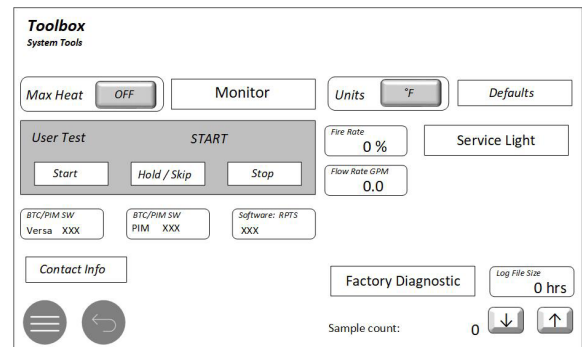

Figure 7. Touchscreen Toolbox Menu

2.4.3. CONTACT INFO

When commissioning the equipment, it may be desirable to include contact information for the equipment supplier or service company. The contact information can be changed by pressing the CONTACT button in the toolbox menu followed by the EDIT button. The PASSWORD screen will appear, which allows for the contact info to be entered or modified. The default password for Raypak product is "REPPASS". The default password for IBC product is "IBCREP". For a complete graphic description of the various screens, pages flow, and basic instructions, consult the Raypak Touchscreen Quick Start User Guide (P/N 241630); or IBC Touchscreen Quick Start User Guide (P/N 241949).

NOTE: For units equipped with a touchscreen, factory recommends performing a "Screen Reboot" to ensure all changes display properly.

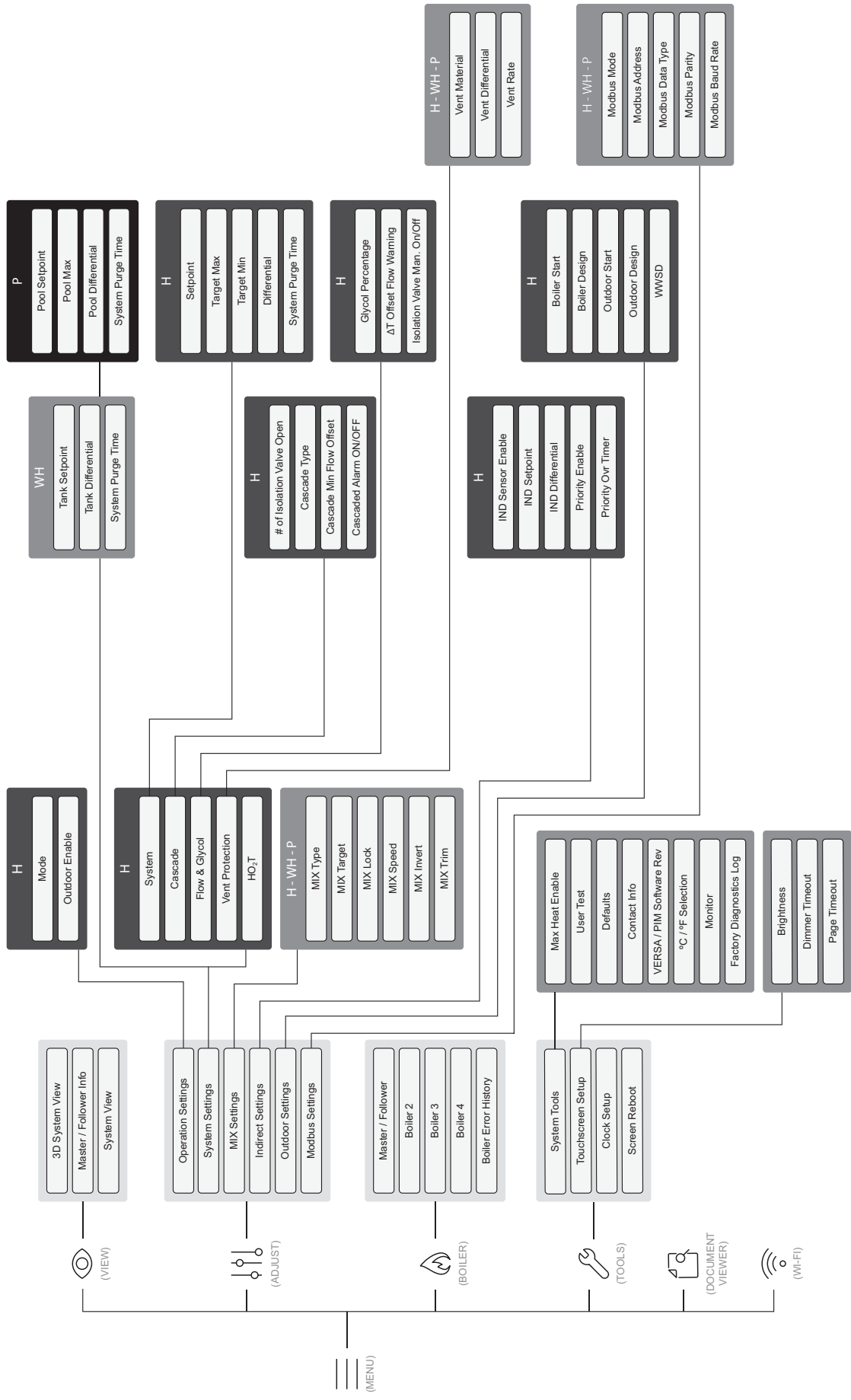





Figure 8. Flow Chart

Icon	When Displayed
VIEW	Menu = View
SETUP	Menu = Setup
BOILER	Menu = Boiler View Menu of Boiler 1, 2, 3 or 4 on FT_BUs
BOILER 1	Menu = Boiler View Menu of Boiler 1 on FT_BUs
BOILER 2	Menu = Boiler View Menu of Boiler 2 connected on FT_Bus
BOILER 3	Menu = Boiler View Menu of Boiler 3 on FT_BUs
BOILER 4	Menu = Boiler View Menu of Boiler 4 on FT_BUs
MONITOR	Menu = Monitor
	Single-boiler or Master Boiler in Cascade
	Menu = View, Solid if Installer Access Level Flashes at 1Hz if OEM Access Level
	Menu = Toolbox
WWSD	Warm Weather Shutdown is active
	Menu = View, Flashes at 1 Hz if one of the connected PIMs is in Lockout Menu = View, Solid if there is a known active error on one of the connected PIMs
Calls	Menu = View/Test
Heat	Menu = View/Test and Heat Call present
DHW	Menu = View/Test and DHW Call present
Pool	Menu = View/Test and Pool Call present
Tank	Menu = View/Test and Tank Call present
Mixing	Shown whenever Cold Water Protection is enabled (VERSA DIP 3).
Setpoint	Menu = View/Test and Setpoint Call present

Icon	When Displayed
Pumps	Menu = View/Test
Boiler Pump	Menu = View/Test and Boiler Pump is on
System Pump	Menu = View/Test and System Pump is on
DHW Pump	Menu = View/Test and DHW Pump is on
Burner	Menu = View/Test
1	Menu = View/Test and PIM 1 is on
2	Menu = View/Test and PIM 2 is on
3	Menu = View/Test and PIM 3 is on
4	Menu = View/Test and PIM 4 is on
(Burner Rate) %	Menu = View/Test and PIM is modulating. Displays current plant firing rate
ModBus	Menu = View and ModBus communication is present
°C	Whenever the item displayed in the number field is a temperature and UNITS = degC
°F	Whenever the item displayed in the number field is a temperature and UNITS = degF
min	Whenever the item displayed in the number field is in minutes
hr	Whenever the item displayed in the number field is in hours
sec	Whenever the item displayed in the number field is in seconds
µA	Whenever the item displayed in the number field is in micro-amps
%	Whenever the item displayed in the number field is in percent
RPM	Whenever the item displayed in the number field is in RPM

Table A. VERSA LCD Display Symbol Descriptions

2.5. VERSA PIM Module

The PIM (Platform Ignition Module) is available in DSI (Direct Spark Ignition), or HSI (Proven Hot Surface Ignition) versions depending on model type. See **Figure 9**.

The PIM integrates the functions of Automatic Ignition Control with temperature regulating and control functions. The PIM is designed for a range of boilers, water heaters, and pool heaters including ON/OFF, staged, and modulating types. The PIM is intended to provide safe lighting and supervision of the burners in a heater.

The PIM is also designed to connect to and receive commands from the VERSA Control Board for higher-level functionality to include indirect DHW, outdoor reset, diagnostic messaging, and other system capabilities. Communication is accomplished using a proprietary protocol on the Ft_Bus and through tN4 bus. The PIM is CSA certified to the ANSI Z21.20 Standard for Thermostats and Automatic Gas Ignition Systems and Components and CAN/CSA C22.2 No. 199-M99. The VERSA PIM also complies with the UL372 Primary Safety Controls for Gas and Oil Fire Appliances (Harmonized version); UL 1998 Software in Programmable Components, 2nd edition and UL 353 Limit Controls.

The PIM provides standard support for 10k ohm @ 77°F (25°C) NTC Curve J Thermistor probes. The Inlet and Outlet/Hi-Limit sensors are directly processed by the PIM. The System, Outdoor, and DHW tank sensors are also connected to the PIM, but are passed through to the VERSA Control Board which is required to provide those additional functions.

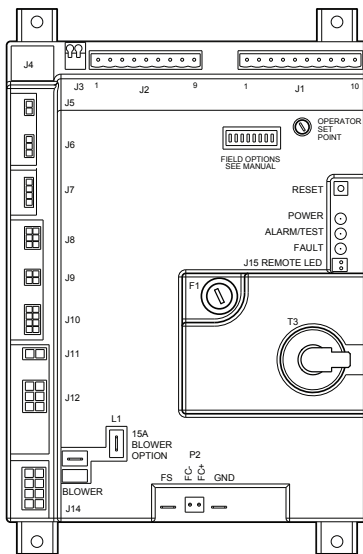

Figure 9. VERSA DSI PIM Module

Auxiliary sensors, such as the indirect supply / pool return sensor, connect directly to the VERSA Control Board for other enhanced functions depending on the mode selected. For detailed wiring information, refer to the product-specific Installation and Operation Manual being installed.

There is an 8-position DIP switch on the PIM that can be field configurable during commissioning. The UP position is “ON” and the DOWN position of each DIP switch is “OFF”. The items in **BOLD** below represent factory defaults settings.

DIP Switch #1 – Operator Differential

ON = Manual Differential

OFF = Auto Differential

DIP Switch #2 – Analog Input Type

ON = Direct Drive

OFF = Target Temperature

DIP Switch #3 – Pipe Configuration

ON = Primary/Secondary (XVers, XVersL and XVers with KOR only) Post Purge ON (all others)

OFF = Primary Only (XVers, XVersL and XVers with KOR only) Post Purge OFF (all others)

DIP Switch #4 – Pump/Valve Exercise Enable

ON = Exercise Active

OFF = Exercise Inactive

DIP Switch #5 – EMS/Demands

ON = EMS Analog Input Only

OFF = VERSA IC Demands Only

DIP Switch #6 – EMS Signal Type

ON = 4-20mA*

OFF = 0-10 VDC

DIP Switch #7 – Freeze Protection

ON = Freeze Protection Active

OFF = Freeze Protection Inactive

DIP Switch #8 – Commission Test

ON = Commission Test Active

OFF = Commission Test Inactive

*NOTE: 4-20mA operation requires the use of an external 500Ω, 1/2W resistor.

2.5.1. PIM Operator Setpoint Dial

The PIM has a setpoint dial that is used to determine the operator setpoint applied to the boiler outlet sensor during “limp-along” operation of the VERSA IC system. The default position of the operator setpoint applied to the boiler outlet sensor dial is the maximum setpoint, which is defined by the PIM parameters defined by the ID card.

The dial can be adjusted down to a user-defined level between the minimum setting of 70°F (21°C) or the maximum allowed by the ID card. **This function is only active during “limp-along” operation (see page 66).**

2.5.2. VERSA IC Unit Type ID Card

The VERSA IC Identification Card (ID Card) is a small circuit card that determines the operating parameters for each individual model by unlocking the correct program within the VERSA PIM. It is permanently affixed to the chassis of the heater and **MUST** be present for the heater to operate. See **Figure 10**.

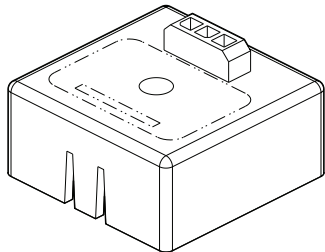

Figure 10. VERSA PIM ID Card

⚠ DANGER: In the event of ID Card failure, field replacement can only be performed by a factory Employee or contracted Representative and must be replaced with an ID Card of the same number. Serious risk of severe personal injury, death or substantial property damage if not correctly serviced.

3. QUICK START SET-UP

1. Determine the piping arrangement for your particular application by referencing the application drawings and descriptions. See **"APPLICATIONS AND MODES"** on page 12.
2. Install the System Sensor (S3), Outdoor Air Sensor (S4), Indirect DHW Sensor (S5) as necessary as depicted in the above referenced Application drawing.
3. Wire the sensors to the VERSA IC system as described on the wiring diagram of the respective model (see model wiring diagrams). Sensor wires should be routed to the heater in dedicated low voltage conduit.

⚠ CAUTION: Sensor and control wiring must **NOT** be run in conduit or chases with line voltage.

4. Ensure that the entire system is ready for operation.
 - a. Water piping properly filled and purged of air?
 - b. Gas pipe properly installed and purged?
 - c. Electrical connections properly installed?
 - d. For cascading systems:
 - i. Are communication wires properly installed between Follower PIM's and the Master VERSA IC?
 - ii. Are the DIP switches properly set for Master/Follower operation?

- e. Vent properly installed and terminated?
 - f. Sensor wires properly routed in dedicated low voltage conduit?
 - g. External interlocks properly installed and wired to VERSA IC, if needed (louver interlock, extractor, external gas valve, site-specific needs, etc.). Refer to Section 9.1 **on page 53** and the wire diagram for your unit for additional information.
5. For CWP (Cold Water Protection) Systems:
 - i. Are the actuators properly installed?. See **"Cold Water Protection (CWP)"** on page 44.
 - ii. Is VERSA DIP #3 turned on?
 6. Turn on system electricity to allow the VERSA IC to be programmed.
 7. For H models go to the ADJUST menu and set the heater MODE as indicated on the Application drawing – 1, 2 or 3. (Mode 1 is for "Stand-Alone" or cascade heaters with no Indirect DHW needs; Mode 2 includes Indirect DHW in the system loop; and Mode 3 includes Indirect DHW in the boiler loop). WH and P models do not require a mode selection as they are configured only for direct DHW or pool heating operation.
 8. Use the Application drawings and descriptions as a guide to set up the control.
 9. A change to a value will be made as soon as you push the ITEM button, change the MENU screen, or wait until the 180-second timer expires.
 10. Should any error be displayed, check the Troubleshooting Section to identify the source of the error and recommended troubleshooting ideas.

3.1. System Sensor Installation

The System Sensor (S3) is required for all cascade or primary/secondary piping configurations unless the unit's firing rate will be controlled by an external source such as our Temp Tracker MOD+ Hybrid sequencer.

Proper placement and method of installation are critical for proper operation of the system. The sensor must be installed in a drywell in conjunction with heat conductive compound. See **Figure 11 on page 12**.

Wire the sensor to the S3 connections. For Hi Delta, MVB, XTherm, XVers, XFiire and IFire units, use pins 6 and 7 on TB1. For XPakFT units, connect the sensor to pins 3 and 4 on PIM J2. Use 18 AWG stranded wire, for a run of up to 500' (152 m). Run in the most direct route possible.

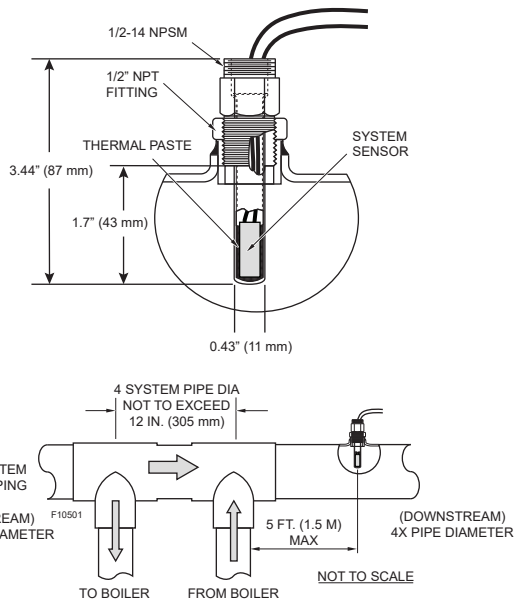

Figure 11. System Sensor Installation (Primary/Secondary)

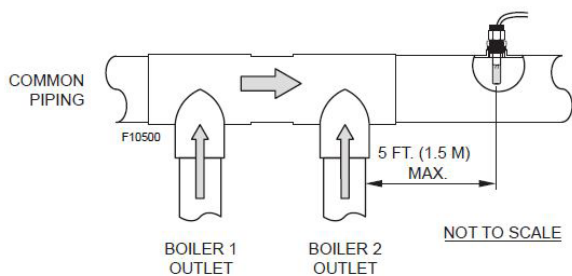

Figure 12. System Sensor Installation on Cascade Primary Systems (XVers, XVersL and XVers with KOR only)

The drywell must be installed no more than 5 equivalent feet (1.52 m) of pipe/ tubing downstream of the de-coupler and installed in such a way that ensures the sensor bulb is in the flow path on primary/secondary configurations. Boilers installed using a primary piping configuration when in multi-boiler cascade requires addition of a system sensor in the common pipe no more than 5 equivalent feet (1.52 m) downstream of the last boiler.

⚠ CAUTION: Be careful when installing the drywell not to over-tighten the well as this can damage the well and may prevent the sensor from fitting properly.

4. APPLICATIONS AND MODES

The VERSA IC system is designed for a wide range of applications. The installer/design engineer should refer to the following drawings for configurations currently supported by the VERSA IC system to determine which

most closely resembles the intended/installed system configuration.

Refer to the section(s) of this manual for instructions outlining the piping logic, sensor locations and settings for best operation of the specific configuration shown.

4.1. Boiler Applications

Hot water heating systems all have unique levels of operating diversity that must be accounted for in the system design. Primary/Secondary systems must always include adequate system flow in excess of the connected boiler flow for proper operation. Where the system flow may drop below the connected boiler flow, a buffer/decoupler may be needed.

Primary loop hydraulic systems require the system flow to be not less than the minimum flow required for all units open to the system. The maximum flow must not exceed the maximum flow allowed for the connected units at any time.

Failure to design for adequate flow (i.e. bypasses, 3-way control valves, flow-limiting balance devices, buffer tanks, etc.) will result in boiler short-cycling and may reduce boiler life. Always contact your local factory representative for system design assistance to avoid these issues.

4.2. Mode 1 - Hydronic Systems without Indirect DHW - Primary/Secondary

This section covers single- or multiple-boiler installations used for individual hydronic heating systems without indirect DHW. **Figure 13** and **Figure 14** show single-boiler systems with and without CWP. The CWP diagrams will show an individual 3-way valve at the boiler (MIX Type = VALVE). The following configurations can be used as fixed setpoint or set up to work in conjunction with an Outdoor Air Reset Sensor (S4) to adjust the target water temperature as the outdoor air temperature changes. See **Table B on page 18**.

4.2.1. Mode 1 Single

⚠ CAUTION: Continuous pumping through the unit is not supported and may cause a non-warrantable failure.

The boiler firing rate will be controlled by the System Sensor (S3). The VERSA IC will provide Max Delta-T (Differential Temperature) control and will cycle the burner if the Max Delta-T is exceeded. Delta-T is measured between Boiler Outlet Sensor (S1) and Boiler Inlet Sensor (S2). See "**System Sensor Installation**" on page 11.

In order to enable Cold Water Protection, VERSA DIP #3 must be set to the ON position. The Cold Water Protection system utilizes a proportional 3-way valve to bypass water from the boiler outlet to the inlet during operation, when the system return water temperature is below the minimum acceptable level as defined in the Installation

and Operation Manual for the product being installed. See "Cold Water Protection (CWP)" on page 44.

The Boiler Pump (P1) runs during any call for burner operation and is delayed "off" as user-defined in the BOILER menu after the burner has shut down. The System Pump (P2) runs whenever the system is enabled for heating and the outdoor air temperature is lower than the WWSD temperature setting (if utilized).

The System Pump is delayed "off" as user-defined in the SETUP menu. MODE 1 is used for this configuration. See SETUP menu items in Table B on page 18. This configuration supports BMS 0-10 VDC input for either temperature or rate control and can be configured for connectivity to BMS via the on-board Modbus port covered later in this manual.

DIP switches #1 and #2 on the VERSA Control Board must be in the ON position to make programming changes. Prior to setting any DIP switches, the heater must be turned off.

NOTE: 0-10VDC firing rate control ignores all sensors except S2 and all functions except Max Delta-T, CWP, Limit and Safety Switches.

NOTE: Factory recommends performing a "Screen Reboot" of the touchscreen to ensure all changes display properly. See Section 15.3 on page 72.

4.2.2. Mode 1 Cascade

Figure 17 through Figure 19 shows the 4 boiler cascade systems for reference, but these configurations can be expanded up to 8 boilers with or without CWP. The CWP diagrams show either an individual 3-way valve at the boiler (MIX Type = VALVE) or a single 3-way valve providing CWP to all connected boilers within the cascade (MIX Type = PLNT).

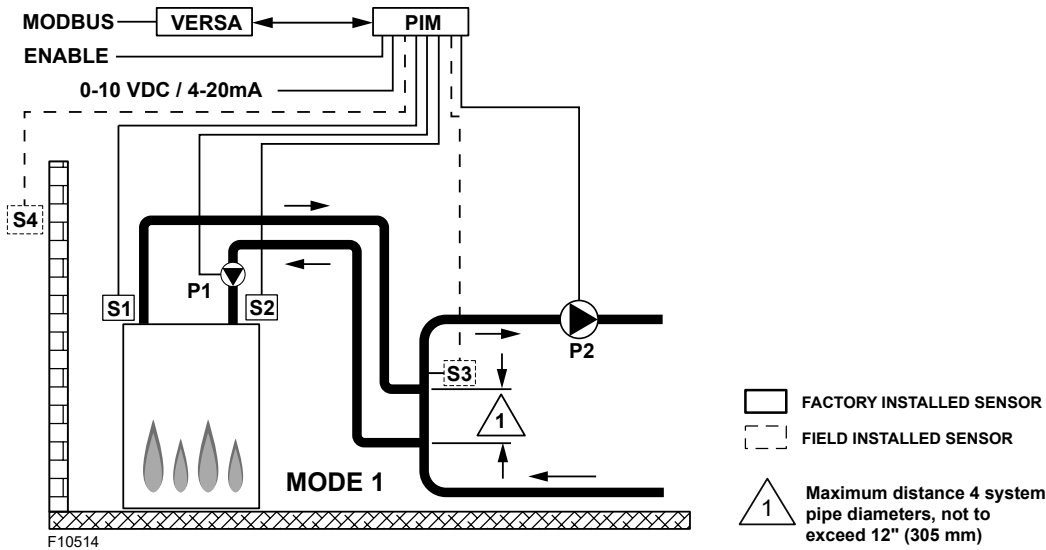

Figure 13. Mode 1 - Hydronic Single-Boiler - Primary/Secondary

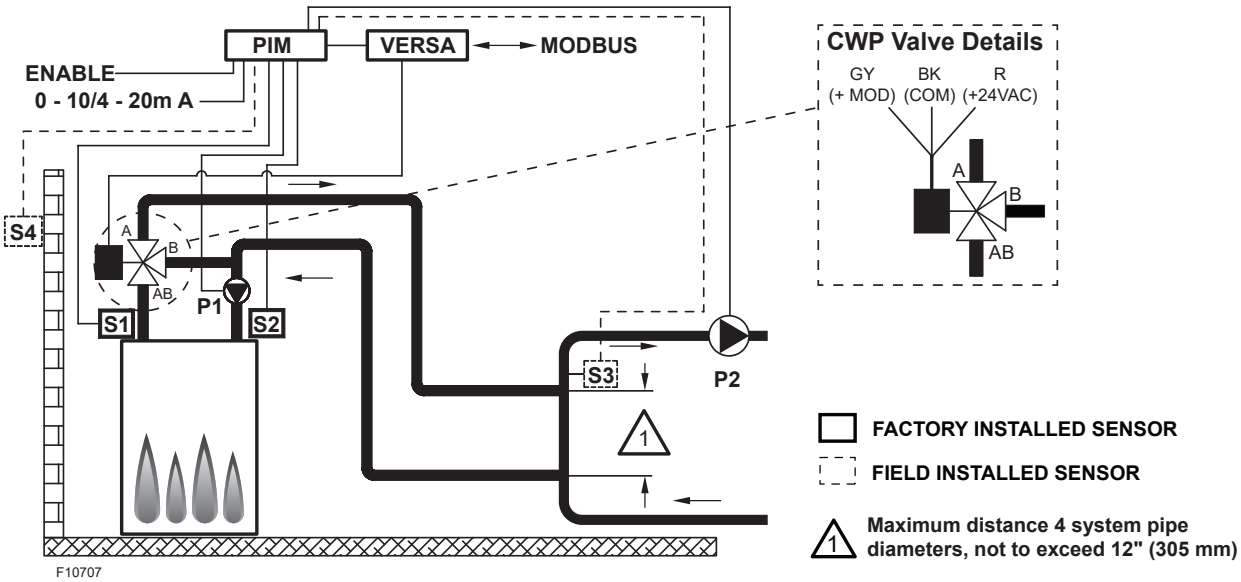

Figure 14. Mode 1 - Hydronic Single-Boiler - Primary/Secondary, CWP (MIX TYPE = VALVE, 3-Way)

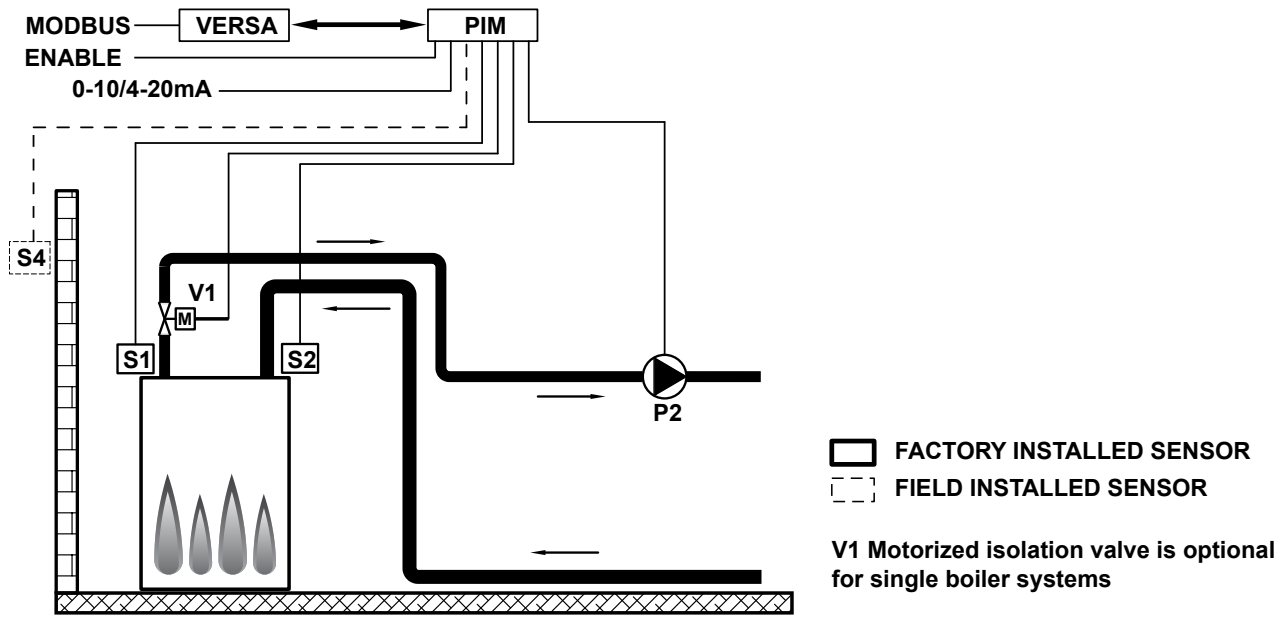

Figure 15. Mode 1 - Single-Boiler with Primary Piping

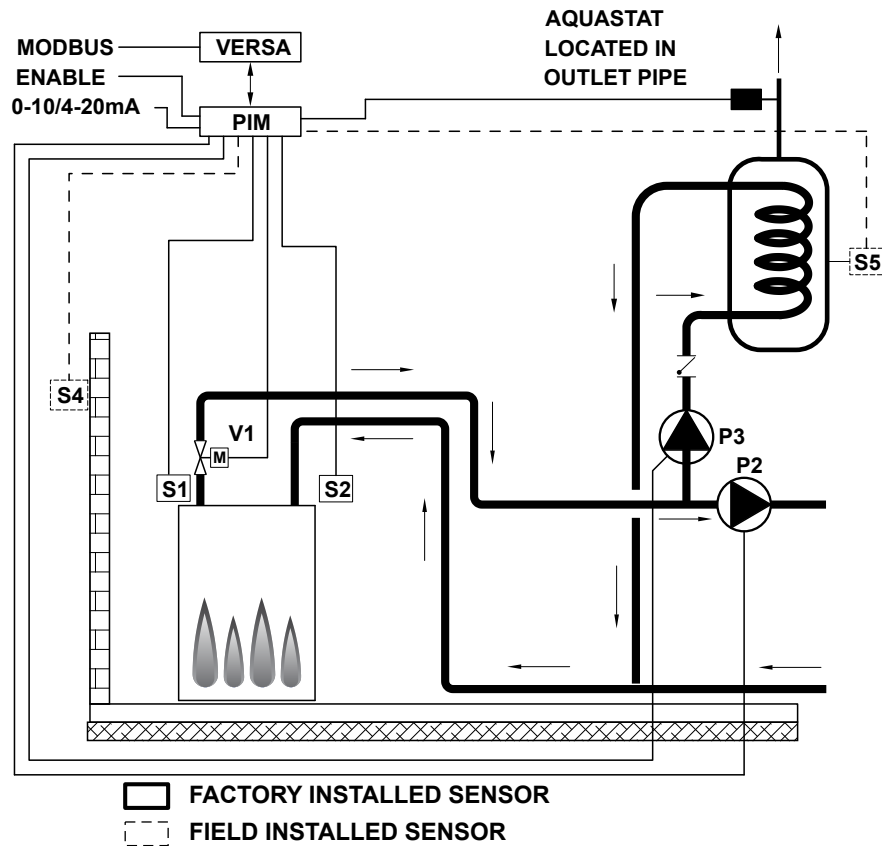

Figure 16. Mode 2 - Single-Boiler with Indirect - Primary Piping

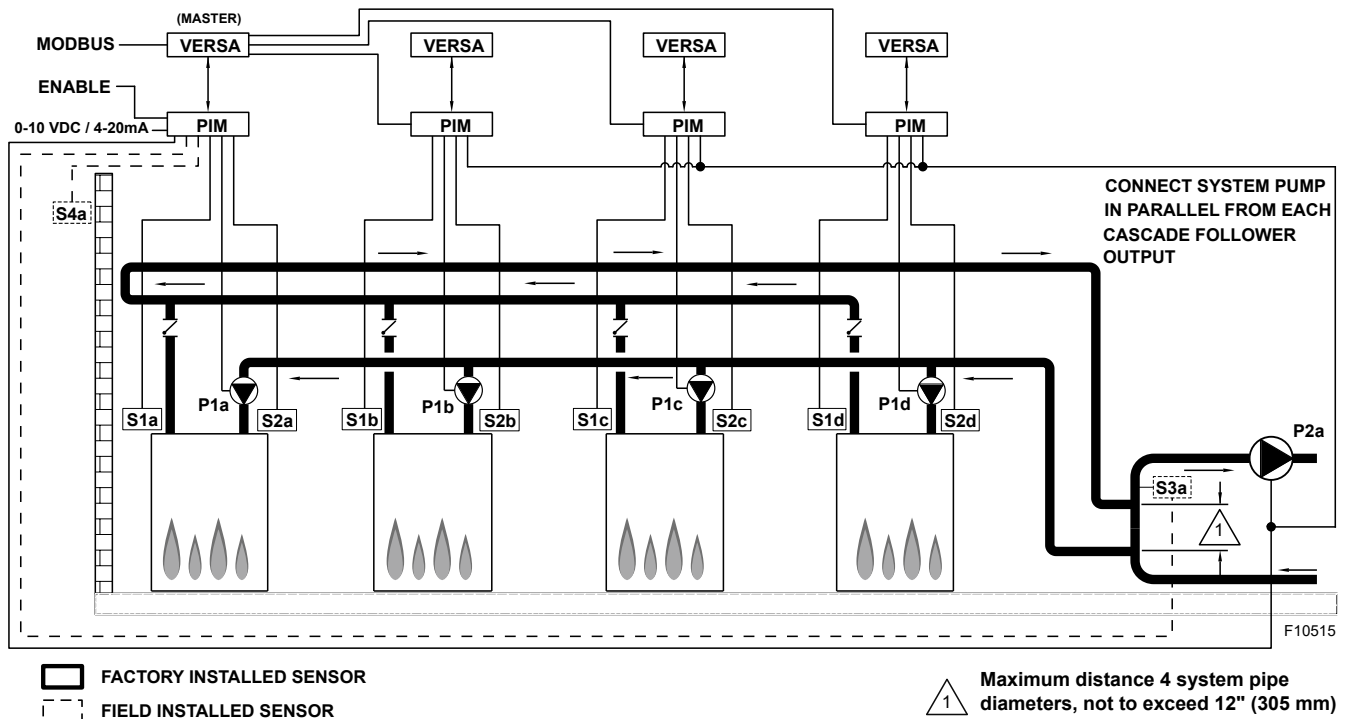

Figure 17. Mode 1 - Hydronic Multi-Boiler - Primary/Secondary

The following configurations can be used as fixed setpoint or set up to work in conjunction with an Outdoor Air Reset Sensor connected to the Master unit (S4a) to adjust the target water temperature as the outdoor air temperature changes.

Reverse/return logic is shown and is recommended to ensure balanced flow through each of the connected boilers.

NOTE: "a" designation represents connection is at Master boiler "A", etc.

The cascade will be controlled by the System Sensor connected to the Master boiler (S3a). See **"System Sensor Installation" on page 11**.

The VERSA IC of each boiler will provide Max Delta-T control to cycle the burner to ensure that the Delta-T is not exceeded (between Boiler Outlet Sensors (S1a-b-c-d) and Boiler Inlet Sensors (S2a-b-c-d)).

In order to enable CWP, VERSA DIP #3 must be set to the ON position. The CWP system utilizes a proportional 3-way valve to bypass water from the boiler outlets to the inlets (S2 a-b-c-d) during operation, when the system return water temperature is below the minimum acceptable level, among all active units, as defined in the Installation and Operation Manual for the product being installed. See **"Cold Water Protection (CWP)" on page 44**.

The Boiler Pumps (P1a-b-c-d) run during any call for the burner on the boiler associated with that pump and are delayed "off" as user-defined in the BOILER menu. The System Pump (P2a) runs whenever the system is enabled for heating and the outdoor air temperature is lower than the WWSD temperature setting (if utilized).

The System Pump is delayed "off" as user-defined in the SETUP menu. It is recommended the system pump be connected in parallel from each cascade follower output, to allow the system pump to be functional during limp-along operation.

Each Follower boiler connects back to the Master boiler via a 2-wire connection for communication within the cascade. All sensors (System (S3a) and Outdoor Air (S4a)) connect to the Master boiler at either the field wiring strip (when equipped), or the PIM J2 or J3 terminal block. Each boiler in the cascade connects to and controls its own respective Boiler Pump (P1a-b-c-d).

The System Pump (P2a) gets its enable signal from the Master boiler. It is important to remember to enable a boiler to be a follower in the cascade by turning DIP switch #2 on the VERSA Control Board to the OFF position for each of the followers. Once the followers have been configured correctly, you must then enable the followers within the SETUP menu of the Master boiler by turning them from OFF to ON. DIP switch #2 on the master boiler must remain ON. See SETUP menu items in **Table B on page 18**.

This configuration supports EMS 0-10 VDC input for temperature control (rate control is not supported in cascade) and can be configured for connectivity to BMS via the on-board Modbus port covered later in this manual.

DIP switches #1 and 2 on the Master VERSA Control Board must be in the ON position to make programming changes. Prior to setting any DIP switches, the heater must be turned off. Prior to enabling the Master boiler, apply power to all units for initial programming of cascade settings.

This is accomplished from the Master boiler user interface.

The next menu items are not necessarily in the order in which they will appear.

NOTE: For units equipped with a touchscreen, factory recommends performing a "Screen Reboot" to ensure all changes display properly.

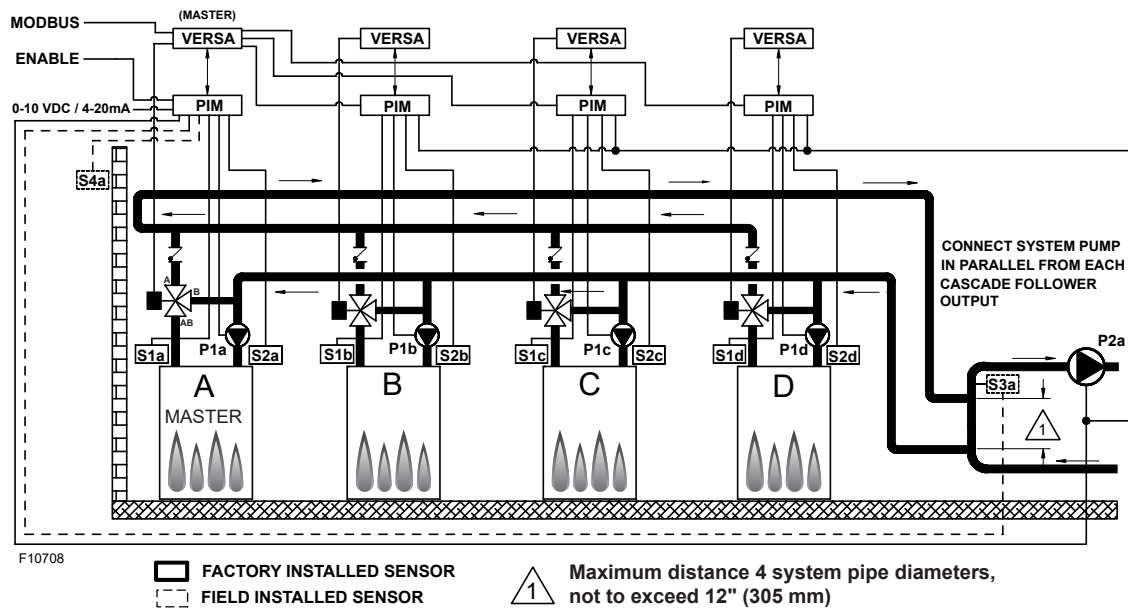

Figure 18. Mode 1 - Hydronic Multi-Boiler - Primary/Secondary (MIX TYPE = VALVE)

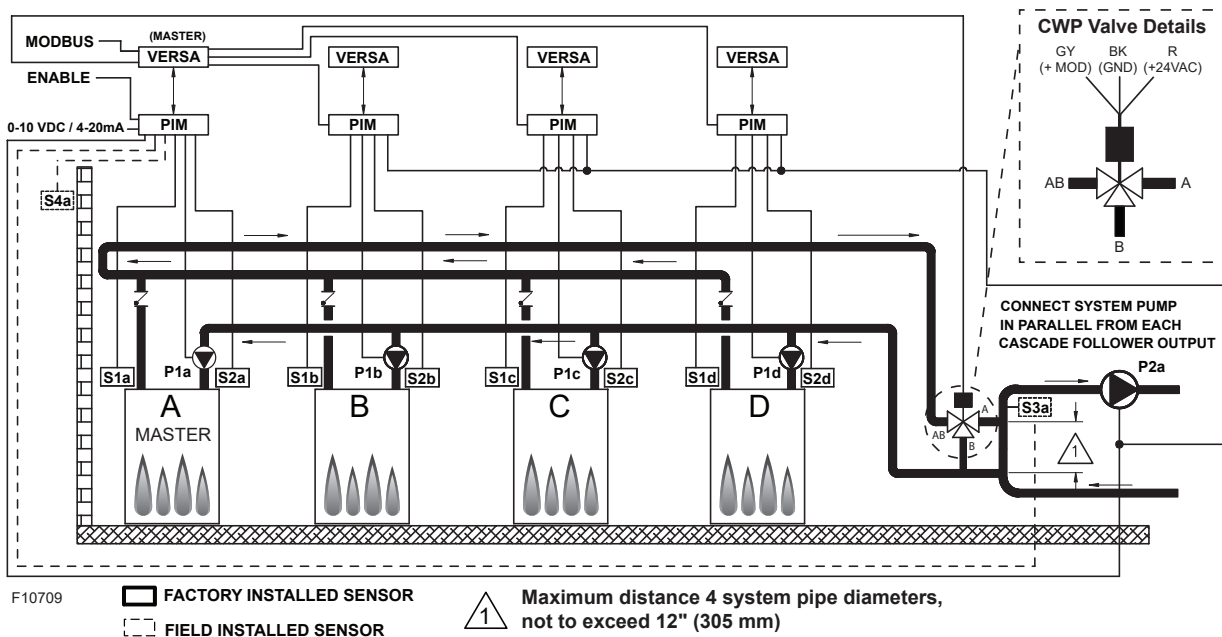

Figure 19. Mode 1 - Hydronic Multi-Boiler - Primary/Secondary (MIX TYPE = PLNT)

Enable followers from appropriate BOILER menu at the master:					
Item	Range	Default	User Settings	When is it Displayed	Description
BOILER 1, 2, 3, 4	ON <> OFF	OFF		FT_Bus Cascade Followers present	FT_Bus 1, 2, 3,4 are connected
The following settings are available in the SETUP/ADJUST Menu:					
TARGET	Setpoint Reset EMS Modbus	SETP		PIM Identity is H EMS = Temp/Rate Modbus = Temp/Rate	RSET = Outdoor Reset SETP = Setpoint EMS = Energy Management System (Analog Target Temp) MODB = Modbus
MODE	1, 2, 3	1		PIM Identity is H TARGET = Rset or Setp	Piping and application configuration
SETPOINT (S3)	XVERS/XVERS L/XVERS KOR: 50 to 180°F (10 to 82°C) XPAKFT/XFIIRE/IFIRE Boiler (H): 50 to 192°F (10 to 89°C) Hi DELTA/MVB/XTHERM 50 TO 220°F (10 to 104°C)	180°F (82°C)		PIM Identity is H	Desired temperature to which the unit will regulate the supply temperature (S3)
TARGET MAX.	XVERS/XVERS L/ XVERS KOR: 180°F (82°C) XPAKFT/XFIIRE/IFIRE Boiler (H): 192°F (89°C) Hi DELTA/MVB/XTHERM 220°F (105°C)	192°F (89°C) 210°F (99°C)		Modbus Rate EMS Rate PIM Identity is H	Maximum Target Boiler Temperature
TARGET MIN.	50 to 180°F (10 to 82°C)	50°F (10°C)		Modbus Rate EMS Rate PIM Identity is H	Minimum Target Boiler Temperature
SYS. PURGE	0:20 sec to 20:00 min	0:20 sec		Modbus Temp/Rate PIM DIP = Purge On	Sets the length of the System Pump Purge
GLYCOL	0 - 50%	50% XVERS 0% All others		Always	To adjust operation based on fluid being heated
UNITS	°F or °C	°F		Always	Show Units Using Icons in Display
When RESET from target screen is selected, the following items will be available for adjustment:					
OUT START	35 to 85°F (1.5 to 30°C)	70°F (21°C)		PIM Identity is H Target = Rset	Outdoor Reset Starting Temp
OUT DESIGN	-60 to 45°F (-51 to 7°C)	10°F (-12°C)		PIM Identity is H Target = Rset	Outdoor Reset Design Temp
BOIL START	35 to 150°F (11 to 66°C)	70°F (21°C)		PIM Identity is H Target = Rset	Starting Boiler Target Temp when Outdoor Temperature is at Outdoor Start
BOIL DESIGN	70 to 200°F (21 to 94°C)	180°F (82°C)		PIM Identity is H Target = Rset	Design Boiler Target Temp when the Outdoor Temp is at Outdoor Design (Hottest Water on Coldest Day)
WWSD	40 to 100°F (5 to 38°C)	70°F (21°C)		Target = Rset PIM Identity is H	The System Warm Weather Shut Down Temperature
When manual differential is selected via PIM DIP switch #1, the following item will appear:					
TARGET DIFF	2 to 42°F (1 to 24°C)	10°F (6°C)		PIM Identity is H PIM DIP = Manual Diff	Differential for Target Boiler Temperature

Item	Range	Default	User Settings	When is it Displayed	Description
The items below correspond to CWP operation. Ensure VERSA DIP #3 is ON to enable CWP.					
MIX TYPE	VALVE, PUMP, PLNT	VALVE		H model & CWP DIP = ON	MIX Type assumes that each individual unit will have the proper wiring and pipe configuration to control its own inlet temperature. For H models using a variable-speed Pump as a CWP method See " Cold Water Protection (CWP) " on page 44
MIX TARGET	50 TO 140°F (10 to 60°C)	120°F (49°C)		CWP DIP = ON	Inlet Target Temperature
MIX LOCK	ON / OFF	OFF		CWP DIP = ON	The equipment will trigger a warning when "MIX Target" is not reached within 7-minutes. MIX LOCK = ON Alarm and lockout, MIX LOCK = OFF Alarm only
MIX TRIM	-5 TO 5	0		CWP DIP = ON	This adjustment is for various types and sizes of units as well as various actuator motor speeds and types supplied by factory
MIX SPEED	SLOW, MED, FAST	MED		CWP DIP = ON	This setting defines speed of response
MIX INV	ON / OFF	OFF		CWP DIP = ON	This option is related to the use of spring-return actuators with a proportional 2- or 3-way valve
When communication with BMS is required user must enable Modbus port using the settings below by selecting other than "OFF" at Mode-Modbus screen the following settings will become available.					
MODE MODBUS	Off, Monitor, Temp, Rate	Monitor		Always	Modbus Operating Mode: Off, Monitor, Temp Control, Rate Control
ADDRESS	1 to 247	1		Modbus On	Modbus Slave Address (= Node ID). When using Protonode, do not use values over 127 (see Installation Manual P/N 241515)
DATA TYPE	RTU or ASCI	RTU		Modbus On	Modbus Data Type
BAUD RATE	2400, 9600, 19K2, 57K6, 115K	19K2		Modbus On	Communication Speed of Network
PARITY	None, Even, Odd	Even		Modbus On	Error Detection of System. Integrator needs this information

For detailed information see "**MODBUS PROTOCOL**" on page 73.

Table B. Mode 1 SETUP menu

4.3. Mode 2 - Hydronic Systems with Indirect DHW - Primary/Secondary

This section covers single or multiple-boiler installations used for individual hydronic heating systems with indirect DHW demand located on the system loop.

Figures 20 through **Figure 21** show single-boiler systems with and without CWP. The CWP diagrams will show an individual 3-way valve at the boiler (MIX Type = VALVE).

The following configurations can be used as fixed setpoint or set up to work in conjunction with an Outdoor Air Reset Sensor (S4) to adjust the target water temperature as the outdoor air temperature changes. See **Table C on page 23**.

⚠ CAUTION: Continuous pumping through the unit is not supported and may cause a non-warrantable failure.

The system can also be set to operate the indirect DHW call with or without priority. The boiler firing rate will be controlled by the System Sensor (S3). The Indirect DHW

Sensor (S5) determines the indirect call/tank setpoint. The VERSA IC system also allows for a thermostat controller (tankstat) to be mounted in the indirect tank and provide a call for indirect operation via contact closure in lieu of the tank sensor. The thermostat wiring connection is either at the field wiring strip, or the PIM J1 terminal block at terminals 8 and 10. When using an indirect DHW Sensor (S5) to control tank temperature, contact closure is required across the indirect override connections for proper operation. See "**Indirect Sensor Selection (IND SENSOR)**" on page 43.

To ensure proper operation during "limp-along" mode, connect an aquastat across the indirect DHW override terminals, or place a jumper across the indirect DHW override terminals and set the PIM operator dial to be equal to DHW Target temperature.

The VERSA IC will provide Max Delta-T (Differential Temperature) control and will cycle the burner if the Max Delta-T is exceeded between Boiler Outlet Sensor (S1) and Boiler Inlet Sensor (S2).

In order to enable Cold Water Protection, VERSA DIP #3 must be set to the ON position. The Cold Water Protection system utilizes a proportional 3-way valve to bypass water from the boiler outlet to the inlet during operation, when the system return water temperature is below the minimum acceptable level as defined in the Installation and Operating Manual for the product being installed. See **"Cold Water Protection (CWP)" on page 44.**

The Boiler Pump (P1) runs during any call for burner operation and is delayed "off" as user-defined in the BOILER menu after the burner has shut down. The System Pump (P2) runs whenever the system is enabled for heating and the outdoor air temperature is lower than the WWSD temperature setting (if utilized). Priority mode toggles the System Pump (P2) off during an indirect call-for-heat. The Indirect Pump (P3) runs during an indirect call-for-heat (CFH) with no "off" delay. The System Pump is delayed "off" as user-defined in the SETUP menu.

DIP switches #1 and 2 on the VERSA Control Board must be in the ON position to make programming changes. Prior to setting any DIP switches, the heater must be turned off.

NOTE: 0-10VDC firing rate control ignores all sensors except S2 and all functions except Max Delta-T, CWP, Limit and Safety Switches.

NOTE: Factory recommends performing a "Screen Reboot" of the touchscreen to ensure all changes display properly. See Section 15.3 on page 72.

⚠ CAUTION: Be careful when installing the drywell not to over-tighten the well as this can damage the well and may prevent the sensor from fitting properly.

4.3.1. Mode 2 Cascade

Figure 20 through Figure 22 show 4 boiler cascade systems for reference, but these configurations can be expanded up to 8 boilers with or without CWP in conjunction with an indirect DHW demand located on the system loop. The CWP diagrams show either an individual 3-way valve at the boiler (MIX Type = VALVE) or a single 3-way valve providing CWP to all connected boilers within the cascade (MIX Type = PLNT). The following configurations can be used as fixed setpoint or set up to work in conjunction with an Outdoor Air Reset Sensor connected to the Master unit (S4a) to adjust the target water temperature as the outdoor air temperature changes.

Reverse/return logic is shown and is recommended to ensure balanced flow through each of the connected boilers. The system can be set to operate the indirect DHW call with or without priority. The system temperature will be controlled by the System Sensor connected to the Master (S3a) during a call for hydronic heat or an indirect call. See **"System Sensor Installation" on page 11.**

The Indirect DHW Sensor (S5a) determines the indirect call based on the user-defined setpoint. The VERSA IC system also allows for a thermostat controller (tankstat) to be mounted in the indirect tank and provide a call for indirect operation via contact closure in lieu of the tank sensor. The thermostat wiring connection is either at the field wiring strip, or the Master PIM J1 terminal block at terminals 8 and 10.

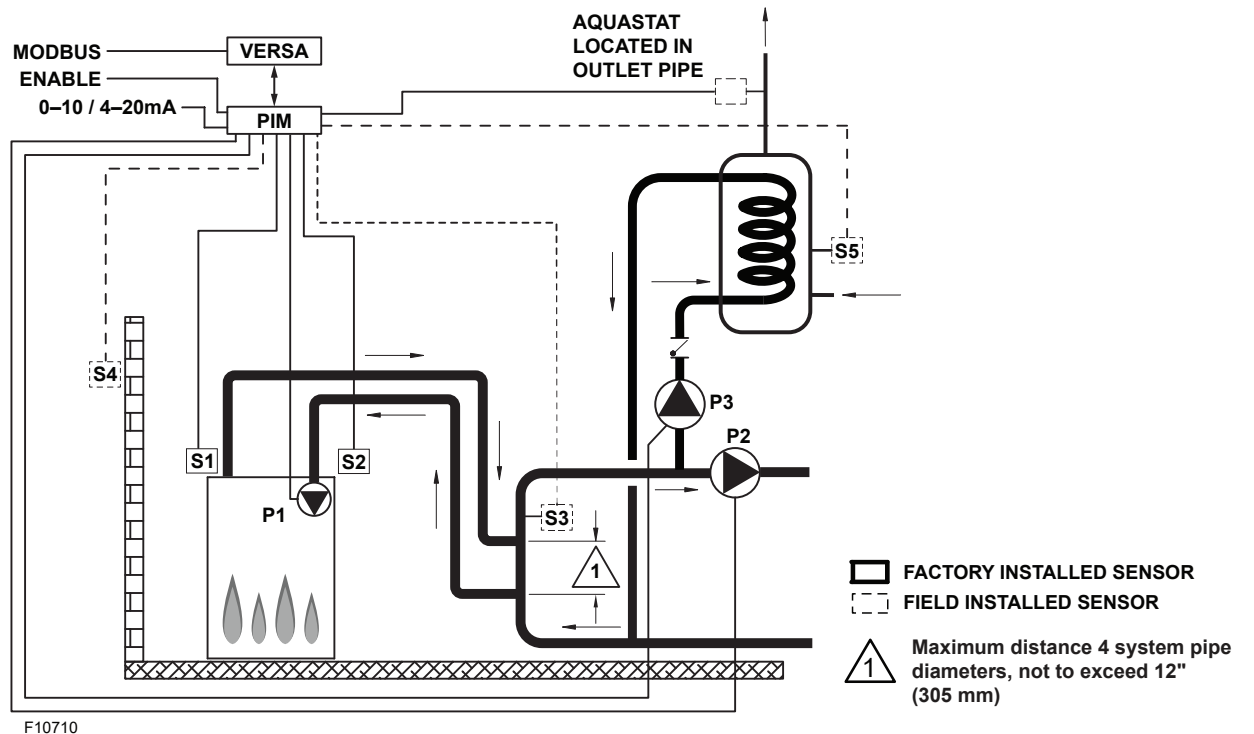

F10710

Figure 20. Mode 2 - Hydronic Primary/Secondary Single-Boiler with Indirect DHW on System Loop

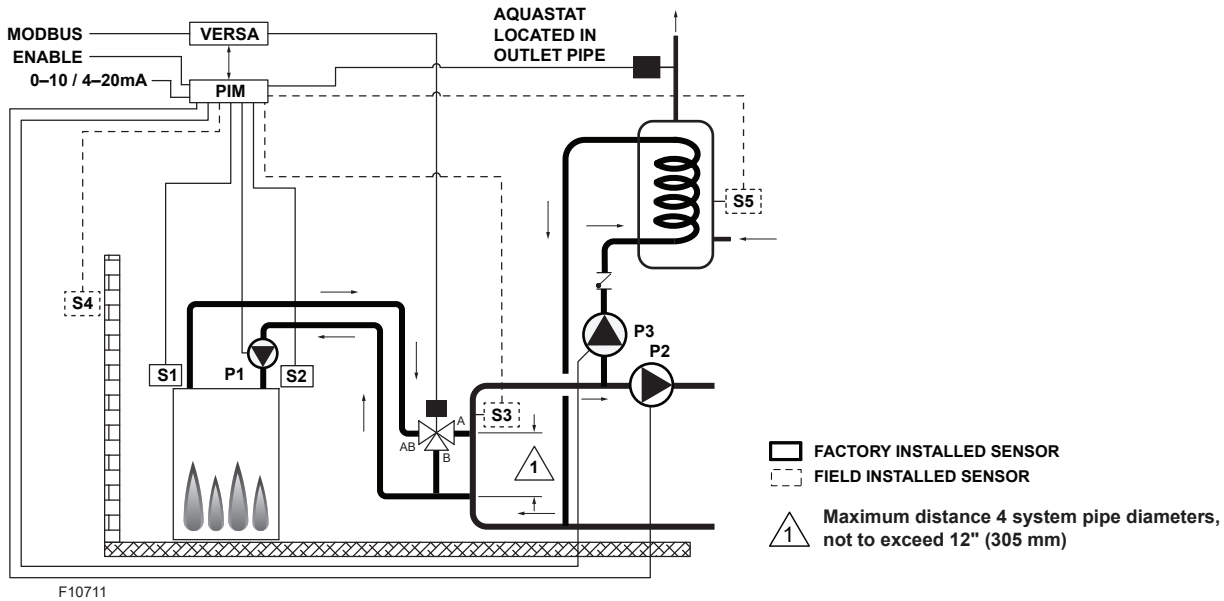

Figure 21. Mode 2 - Hydronic Primary/Secondary Single-Boiler with Indirect DHW on System Loop and CWP (MIX TYPE = VALVE)

When using an indirect DHW sensor to control tank temperature, contact closure is required across the indirect override connections for proper operation. See **"Indirect Sensor Selection (IND SENSOR)"** on page 43.

To ensure proper operation during "limp-along" mode connect an aquastat across the indirect DHW override terminals of the Master unit, install a jumper across the indirect DHW terminals of Follower units, and set the rest of the Follower PIM's operator dial to be equal to DHW Target temperature. In lieu of an aquastat across the indirect DHW override terminals of the Master unit, a jumper may be used.

This configuration requires all PIM operator dials be set to DHW Target temperature to prevent an over-temp condition from occurring during "limp-along".

It is also recommended the system pump and DHW pump be connected in parallel from each cascade Follower, to allow these pumps to be functional during "limp-along" operation. During an indirect CFH with or without priority selected, the cascade firing rate is determined by the System Supply Sensor (S3a) temperature. The VERSA IC will provide Max Delta-T control to cycle the burner if the Max Delta-T is exceeded between Boiler Outlet Sensors (S1a-b-c-d) and Boiler Inlet Sensors (S2a-b-c-d).

In order to enable Cold Water Protection, VERSA DIP #3 must be set to the ON position. The Cold Water Protection system utilizes a proportional 3-way valve to bypass water from the boiler outlets to the inlets (S2 a-b-c-d) during operation, when the system return water temperature is

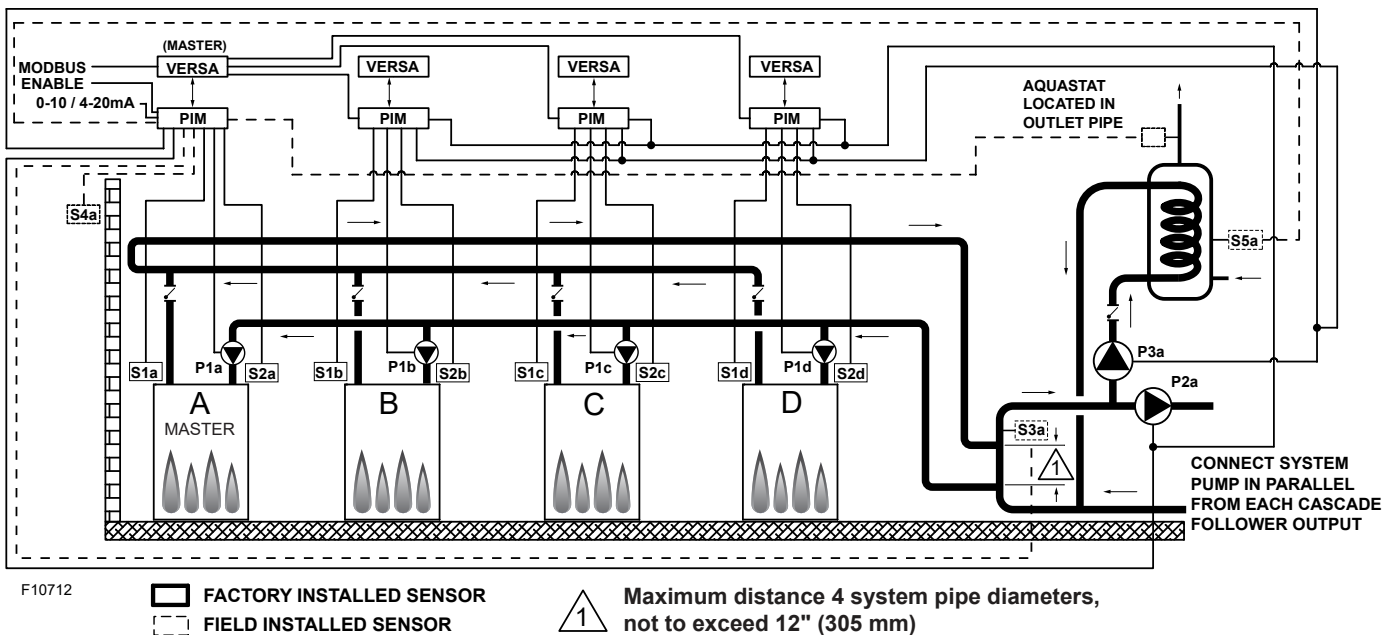

Figure 22. Mode 2 - Hydronic Primary/Secondary Multi-Boiler with Indirect DHW on System Loop

below the minimum acceptable level among all active units, as defined in the Installation and Operating manual for the product being installed. See **"Cold Water Protection (CWP)"** on page 44.

Priority mode toggles off the System Pump (P2a) when an indirect CFH is present. Boiler Pumps (P1a-b-c-d) run in conjunction with their associated burner during all heat calls regardless of priority. The Indirect DHW pump (P3a) runs during an indirect CFH with no "off" delay. The Boiler

Pumps (P1a-b-c-d) are delayed "off" as user-defined in the BOILER menu and System Pump (P2a) is delayed "off" in the SETUP menu.

The System Pump (P2a) runs whenever the system is enabled for heating and the outdoor air temperature is lower than the WWSD temperature setting (if utilized) unless an indirect CFH is present with priority.

DIP switches #1 and 2 on the VERSA Master Control Board must be in the ON position to make programming

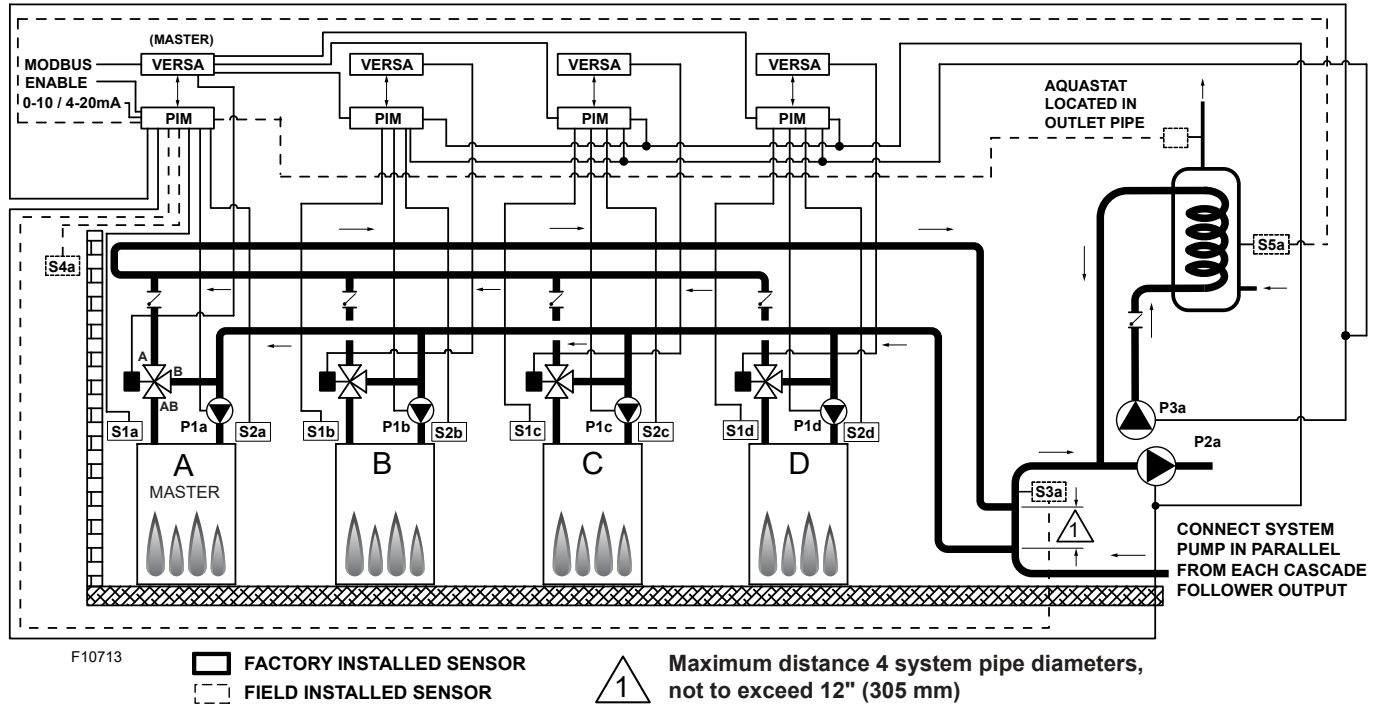

Figure 23. Mode 2 - Hydronic Primary/Secondary Multi-Boiler with Indirect DHW on the System Loop with CWP (MIX TYPE = VALVE)

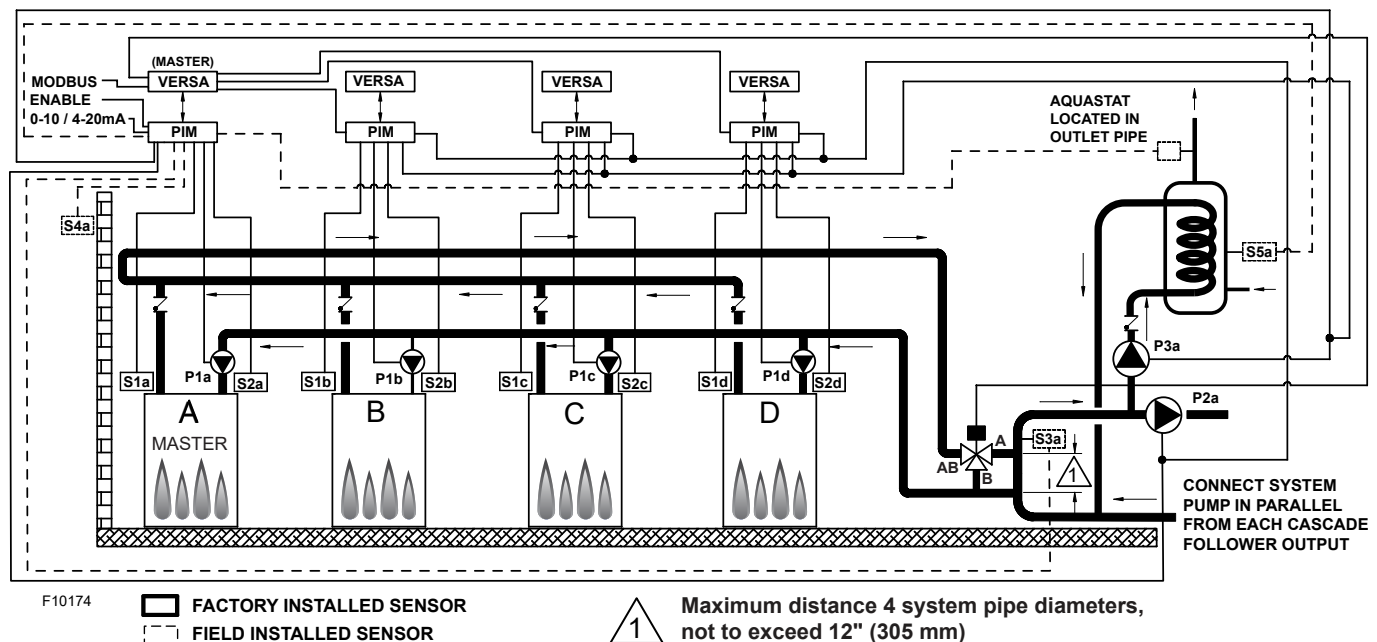

Figure 24. Mode 2 - Hydronic Primary/Secondary Multi-Boiler with Indirect DHW on System Loop, with CWP (MIX TYPE = PLNT)

changes. Prior to setting any DIP switches the heater must be turned off. It is important to remember to enable a boiler to be a Follower in the cascade by turning DIP switch #2 on the VERSA Control Board to the OFF position for each of the Followers.

To enable Follower boilers, scroll to the SETUP menu and, using the item button, scroll to the individual boilers and toggle from OFF to ON to allow them to operate when commanded by the Master to run. Prior to enabling the Master boiler, apply power to all units for initial programming of cascade settings.

This is accomplished from the Master boiler user interface. The next menu items are not necessarily in the order in which they will appear. Enable followers from appropriate BOILER menu at the master:

NOTE: Factory recommends performing a “Screen Reboot” of the touchscreen to ensure all changes display properly. See Section 15.3 on page 72.

NOTE: For cascaded systems with TN_bus followers, boiler Enable/Disable must be done locally.

Item	Range	Default	User Settings	When is it Displayed	Description
BOILER 1, 2, 3, 4	ON <> OFF	OFF		FT_Bus Cascade Followers present	FT_Bus 1, 2, 3, 4 are connected

The following settings are available in the SETUP/ADJUST Menu. Go to MODE screen within SETUP menu and change MODE = 2 to enable the settings for the configuration described along this section:

Item	Range	Default	User Settings	When is it Displayed	Description
TARGET	Reset - Setpoint EMS Modbus	SETP		PIM Identity is H EMS = Temp/Rate Modbus = Temp/Rate	RSET = Outdoor RSET = Outdoor Reset SETP = Setpoint EMS = Energy Management System (Analog Target Temperature) MODB = Modbus, SETP = Setpoint
MODE	1, 2, 3	1		PIM Identity is H Target = Rset or Setp	Piping and application configuration
SETPOINT	XVERS/XVERS L/XVERS KOR: 50 to 180°F (10 to 82°C) XPAKFT/XFIIRE/IFIRE Boiler (H): 50 to 192°F (10 to 89°C) Hi DELTA/MVB/XTHERM 50 TO 220°F (10 to 104°C)	180°F (82°C)		PIM Identity is H	Piping and application configuration
TARGET MAX.	XVERS/XVERS L/XVERS KOR: 180°F (82°C) XPAKFT/XFIIRE/IFIRE Boiler (H): 192°F (89°C) Hi DELTA/MVB/XTHERM 220°F (105°C)	192°F (89°C) 210°F (99°C)		Modbus Rate EMS Rate PIM Identity is H	Maximum Target Boiler Temperature
TARGET MIN.	50 to 180°F (10 to 82°C)	50°F (10°C)		Modbus Rate EMS Rate PIM Identity is H	Minimum Target Boiler Temperature
SYS. PURGE	0:20 to 20:00 min	0:20 sec		Modbus Temp/Rate PIM DIP = Purge On	Sets the length of the System Pump Purge
GLYCOL	0 - 50%	50% XVERS 0% All others		Always	To adjust operation based on fluid being used
UNITS	°F or °C	°F		Always	Show Units Using Icons in Display

When RESET from target screen is selected the following items will be available for adjustment:

OUT START	35 to 85°F (1.5 to 29.5°C)	70°F (21°C)		PIM Identity is H Target = Rset	Outdoor Reset Starting Temperature
OUT DESIGN	-60 to 45°F (-51 to 7°C)	10°F (-12°C)		PIM Identity is H Target = Rset	Outdoor Reset Design Temperature
BOIL START	35 to 150°F (1.5 to 65.5°C)	70°F (21°C)		PIM Identity is H Target = Rset	Starting Boiler Target Temperature when Outdoor Temperature is at Outdoor Start
BOIL DESIGN	70 to 200°F (21 to 93.5°C)	180°F (82°C)		PIM Identity is H Target = Rset	Design Boiler Target Temperature when the Outdoor Temperature is at Outdoor Design (Hottest Water on Coldest Day)
WWSD	40 to 100F (4.5 to 38°C)	70F (21°C)		Target = Rset PIM Identity is H	The System Warm Weather Shut Down Temperature

When manual differential is selected via PIM DIP switch #1, the following item will appear:

TARGET DIFF	2 to 42°F (1 to 23.5°C)	10°F (5.5°C)		PIM Identity is H PIM DIP = Manual Diff	Differential for Target Boiler Temperature
-------------	----------------------------	-----------------	--	--	--

The next items are shown and available for adjustment within the SETUP / ADJUST menu while MODE 2 is selected:

Item	Range	Default	User Settings	When is it Displayed	Description
IND. SENSOR	ON - OFF	OFF		PIM Identity is H MODE = 2 or 3	Selects whether a DHW sensor is used
IND. SETP.	Off, 50 to 180°F (10 to 82°C)	140°F (60°C)		PIM Identity is H MODE = 2 or 3 IND Sensor = ON	Target Indirect DHW Temperature. IND SENSOR is Selected
IND. DIFF	2 to 10°F (1°C to 6°C)	6°F (4°C)		PIM Identity is H MODE = 2 or 3 IND Sensor = ON	Differential for the target indirect DHW tank.
IND. SUPPLY	OFF, 70 to 200°F (21 to 94°C)	180°F (82°C)		PIM Identity is H MODE = 2 or 3 IND Sensor = OFF	Target boiler temperature at S3 for the DHW heat exchanger during indirect DHW operation
IND PRIORI	OFF - ON	OFF		PIM Identity is H MODE = 2	Selects whether or not indirect DHW priority is active during indirect DHW operation
PRI OVR	Au, 0:10 to 2:00 hr	Au		PIM Identity is H DHW Priority = ON	Sets the length of the priority override time

The items below correspond to CWP operation. Ensure VERSA DIP #3 is ON to enable CWP.

MIX TYPE	VALVE, PUMP, PLNT	VALVE		H model and CWP DIP = ON	MIX Type assumes that each individual unit will have the proper wiring and pipe configuration to control its own inlet temperature. For H models using a variable-speed Pump as a CWP method see "Cold Water Protection (CWP)" on page 44
MIX TARGET	50 TO 140°F (10 to 60°C)	120°F (49°C)		CWP DIP = ON	Inlet Target Temperature
MIX LOCK	ON / OFF	OFF		CWP DIP = ON	The equipment will trigger a warning when "MIX Target" is not reached within 7-minutes. MIX LOCK = ON Alarm and lockout, MIX LOCK = OFF Alarm only
MIX TRIM	-5 TO 5	0		CWP DIP = ON	This adjustment is for various types and sizes of units as well as various actuator motor speeds and types supplied by factory
MIX SPEED	SLOW, MED, FAST	MED		CWP DIP = ON	This setting defines speed of response
MIX INV	ON / OFF	OFF		CWP DIP = ON	This option is for the spring-return actuators with a proportional 2-way or 3-way valve

When communication with BMS is required, user must enable Modbus port using the settings below by selecting other than "OFF" at Mode-Modbus screen. The following settings will become available.

MODE MODBUS	Off, Monitor, Temp, Rate	Monitor		Always	Modbus Operating Mode: Off, Monitor, Temp Control, Rate Control
ADDRESS	1 to 247	1		Modbus On	Modbus Slave Address (= Node ID). When using Protonode, do not use values over 127 (see Installation Manual P/N 241515)
DATA TYPE	RTU or ASCI	RTU		Modbus On	Modbus Data Type
BAUD RATE	2400, 9600, 19K2, 57K6, 115K	19K2		Modbus On	Communication Speed of Network
PARITY	None, Even, Odd	Even		Modbus On	Error Detection of System. Integrator needs this information

Table C. Mode 2 SETUP menu

4.4. Mode 3 - Hydronic Systems with Indirect DHW

This section covers a single-boiler used for hydronic heating in conjunction with an indirect DHW demand located on the boiler loop. **Figure 25** and **Figure 26** will show single-boiler systems with and without CWP. The CWP diagrams will show an individual 3-way valve at the boiler (MIX Type = VALVE). The following configurations can be used as fixed setpoint or set up to work in conjunction with an Outdoor Air Reset Sensor (S4) to adjust the target water temperature as the outdoor air temperature changes. See **Table D on page 29**.

4.5. Mode 3 Single

Primary/secondary piping is the only method supported by the factory for this mode to ensure proper boiler and system functionality while achieving maximum system efficiency.

⚠ CAUTION: Continuous pumping through the unit is not supported and may cause a non-warrantable failure.

The system will operate the indirect DHW call with priority function only. The system will be controlled by the System Sensor (S3) whenever the indirect CFH is not active. See **"System Sensor Installation" on page 11**.

The Indirect Sensor (S5) determines the indirect call/tank setpoint. The VERSA IC system also allows for a thermostat controller (tankstat) to be mounted in the indirect tank and provide a call for indirect operation via contact closure in lieu of the tank sensor.

The thermostat controller wiring connection is either at the field wiring strip, or the PIM J1 terminal block at terminals 8 and 10. When using an indirect DHW sensor to control tank temperature, contact closure is required across the

indirect override connections for proper operation. See **"Indirect Sensor Selection (IND SENSOR)" on page 43**.

To ensure proper operation during "limp-along" mode, connect an aquastat across the indirect DHW override terminals, or install a jumper across the Indirect DHW override terminals and set PIM operator dial to be equal to DHW Target temperature to prevent an over-temperature condition from occurring. During an indirect CFH the firing rate is determined by the Indirect Supply (or Target MAX) at the Indirect Supply Sensor (S6). It is important to install this Sensor in a drywell no more than 5' (1.52 m) from the junction between the boiler loop and Indirect loop for best performance. See **Figure 11 on page 12**.

The VERSA IC will provide Max Delta-T (Differential Temperature) control and will cycle the burner if the Max Delta-T is exceeded between Boiler Outlet Sensor (S1) and Boiler Inlet Sensor (S2).

In order to enable Cold Water Protection, VERSA DIP #3 must be set to the ON position. The Cold Water Protection system utilizes a proportional 3-way valve to bypass water from the boiler outlet to the inlet during operation, when the system return water temperature is below the minimum acceptable level as defined in the Installation and Operating manual for the product being installed. See **"Cold Water Protection (CWP)" on page 44**.

The Boiler Pump (P1) runs during any call for burner operation and is delayed "off" as user-defined in the BOILER menu after the burner has shut down. The System Pump (P2) runs whenever the system is enabled for heating and the outdoor air temperature is lower than the WWSD temperature setting (if utilized). An indirect DHW CFH will toggle the System Pump (P2) off until the indirect CFH is satisfied or the priority timer has elapsed allowing the system to return to heating mode. The Indirect

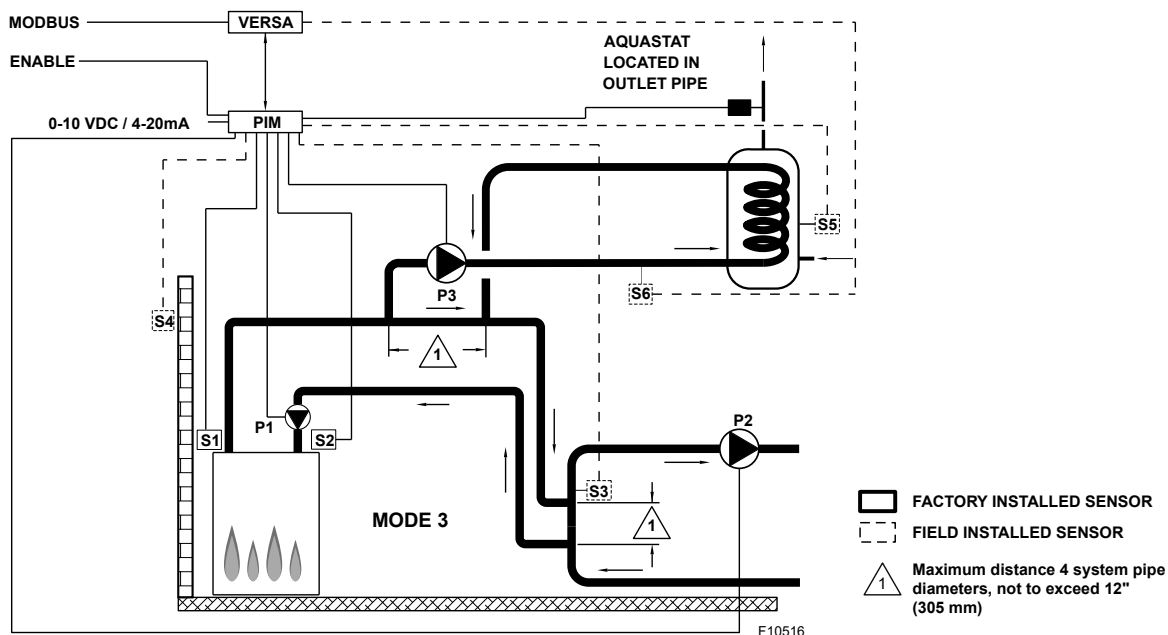

Figure 25. Mode 3 - Hydronic Single-Boiler with Indirect DHW on Boiler Loop

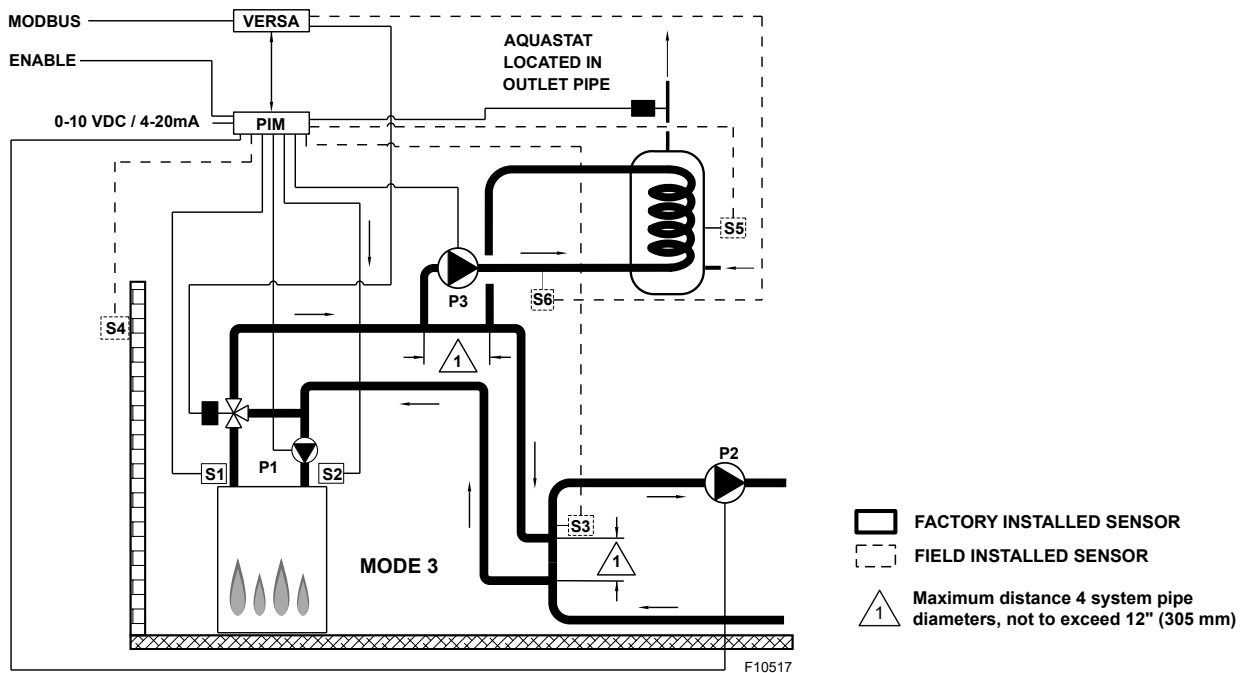

Figure 26. Mode 3 - Hydronic Single-Boiler with Indirect DHW on Boiler Loop and CWP (MIX TYPE = VALVE)

DHW Pump (P3) runs during an indirect CFH with no “off” delay. The System Pump is delayed “off” as user-defined in the SETUP menu.

Mode 3 is used for this configuration. DIP switches #1 and 2 on the VERSA Control Board must be in the ON position to make programming changes. Prior to setting any DIP switches, the heater must be turned off.

NOTE: 0-10VDC firing rate control ignores all sensors except S2 and all functions except Max Delta-T, CWP, Limit and Safety Switches.

NOTE: Factory recommends performing a “Screen Reboot” of the touchscreen to ensure all changes display properly. See Section 15.3 on page 72.

4.5.1. Mode 3 Cascade

Figure 27 through Figure 29 show 4 boiler cascade systems for reference, but these configuration can be expanded up to 8 boilers with or without CWP in conjunction with an indirect DHW demand located on the boiler loop. The CWP diagrams will show either an individual 3-way valve at the boiler (MIX Type = VALVE) or a single 3-way valve providing CWP to all connected boilers within the cascade (MIX Type = PLNT). The following configurations can be used as fixed setpoint or set up to work in conjunction with an Outdoor Air Reset Sensor connected to the Master boiler (S4a) to adjust the target water temperature as the outdoor air temperature changes.

Reverse/return logic is shown and is recommended to ensure balanced flow through each of the connected boilers. Primary/secondary is the only method supported by the factory for this mode to ensure proper boiler and system functionality while achieving maximum system efficiency.

The system will operate the indirect DHW call with priority only. The cascade firing rate will be controlled by the System Supply Sensor connected to the Master boiler (S3a) whenever the indirect CFH is not active. See **“System Sensor Installation” on page 11**. The Indirect DHW Sensor (S5a) determines the indirect call/tank setpoint. When using an indirect DHW sensor to control tank temperature, contact closure is required across the indirect override connections for proper operation.

To ensure proper operation during “limp-along” mode, connect an aquastat across the indirect DHW override terminals of the Master unit, install a jumper across the indirect DHW terminals of the Follower units and set the rest of the Follower PIM’s operator dial to be equal to DHW Target temperature. In lieu of an aquastat across the indirect DHW override terminals of the Master unit, a jumper may be used. This configuration requires all PIM operator dials be set to DHW Target temperature to prevent an over-temp condition from occurring during “limp-along”.

It is also recommended the system pump and DHW pump be connected in parallel from each cascade Follower, to allow these pumps to be functional during limp-along operation. During an indirect call-for-heat, the firing rate is determined by the Indirect Supply (or Target MAX) at

the Indirect Supply Sensor (S6a). It is important to install this Sensor in a drywell no more than 5' (1.52 m) from the junction between the boiler loop and Indirect loop for best performance. See **Figure 11 on page 12**.

The system will provide Max Delta-T control to cycle the burner if the Max Delta-T is exceeded between Boiler Outlet Sensors (S1a-b-c-d) and Boiler Inlet Sensors (S2a-b-c-d).

In order to enable Cold Water Protection, VERSA DIP #3 must be set to the ON position. The Cold Water Protection system utilizes a proportional 3-way valve to bypass water from the boiler outlets to the inlets of all active units (S2 a-b-c-d) during operation when the system return water temperature is below the minimum acceptable level, as defined in the Installation and Operating manual for the product being installed. See **"Cold Water Protection (CWP)" on page 44**.

Priority mode toggles off the System Pump (P2a) when an indirect CFH is present. Boiler Pumps (P1a-b-c-d) run in conjunction with their associated burner during all heat calls regardless of priority. The Indirect DHW Pump (P3a) runs during an indirect CFH with no "off" delay.

The Boiler Pumps (P1a-b-c-d) and System Pump (P2a) delay "off" as user-defined in the ADJUST menu. The System Pump (P2a) runs whenever the system is enabled for heating and the outdoor air temperature is lower than the WWSD temperature setting (if utilized) unless an indirect call for-heat is present with priority. DIP switches #1 and 2 on the VERSA Master Control Board must be in the ON position to make programming changes. Prior to setting any DIP switches, the heater must be turned off.

It is important to remember to enable a boiler to be a follower in the cascade by turning DIP switch #2 on the VERSA Control Board to the OFF position for each of the followers.

To enable Follower boilers, scroll to the SETUP menu at the Master boiler and, using the item button, scroll to the individual boilers and toggle from OFF to ON to allow them to operate when commanded by the Master to run.

Prior to enabling the Master boiler, apply power to all units for initial programming of cascade settings. This is accomplished from the Master boiler user interface.

The next menu items are not necessarily in the order in which they will appear.

NOTE: Factory recommends performing a "Screen Reboot" of the touchscreen to ensure all changes display properly. See Section 15.3 on page 72.

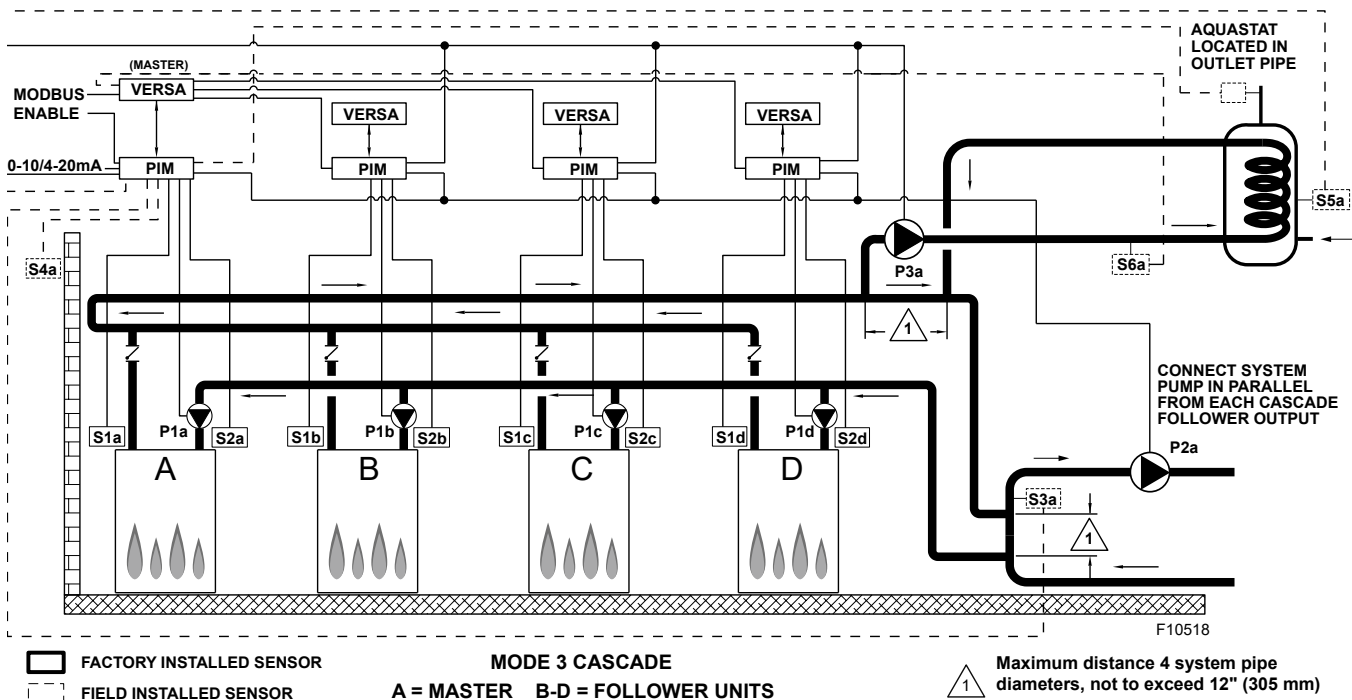

Figure 27. Mode 3 - Hydronic Multi-Boiler with Indirect DHW on Boiler Loop

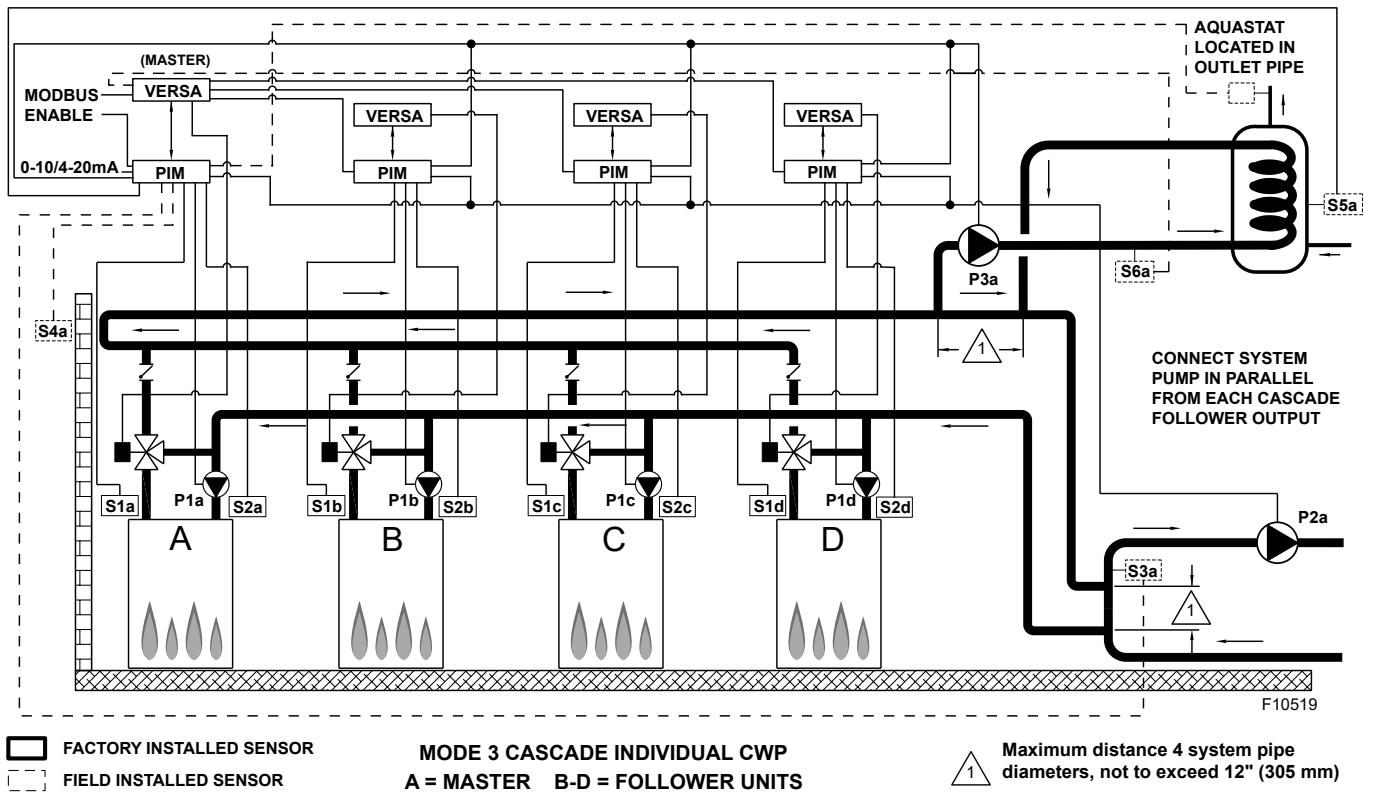

Figure 28. Mode 3 - Hydronic Primary/Secondary Multi-Boiler with Indirect DHW on Boiler Loop and CWP (MIX TYPE = VALVE)

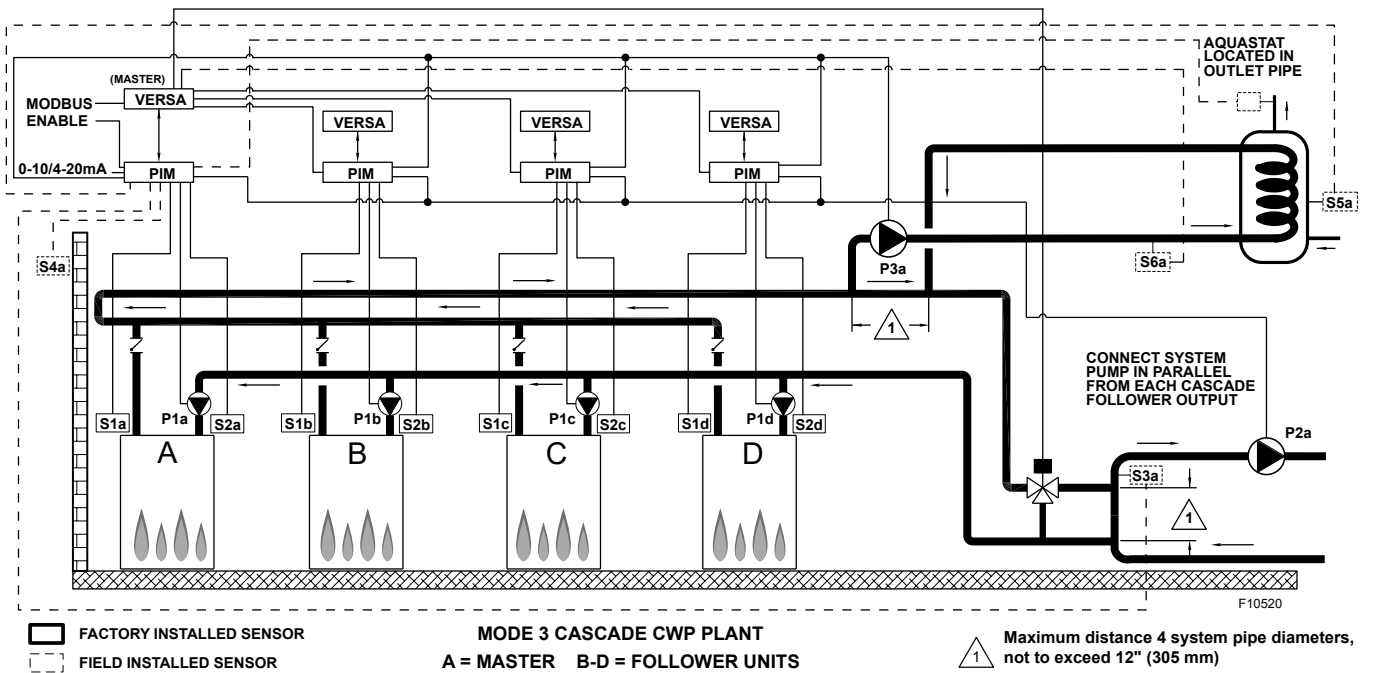

Figure 29. Mode 3 - Hydronic Primary/Secondary Multi-Boiler with Indirect DHW on Boiler Loop, with CWP (MIX TYPE = PLNT)

Enable followers from appropriate BOILER menu at the master:

Item	Range	Default	User Settings	When is it Displayed	Description
BOILER 1, 2, 3, 4	ON <> OFF	OFF		FT_Bus Cascade Followers present	FT_Bus 2, 3, 4 are connected

The following settings are available in the SETUP/ADJUST Menu. Go to MODE screen within SETUP menu and change MODE = 3 to enable the settings for the configuration described along this section:

Item	Range	Default	User Settings	When is it Displayed	Description
TARGET	Reset Setpoint EMS Modbus	SETP		PIM Identity is H EMS = Temp/Rate Modbus = Temp/Rate	RSET = Outdoor Reset SETP = Setpoint EMS = Energy Management System (Analog Target Temperature) MODB = Modbus
MODE	1, 2, 3	1		PIM Identity is H Target = Rset or Setp	Piping and application configuration
SETPOINT	XVERS/XVERS L/ XVERS KOR: 50 to 180°F (10 to 82°C) XPAKFT/XFIIRE/IFIRE Boiler (H): 50 to 192°F (10 to 89°C) Hi DELTA/MVB/XTHERM 50 TO 210°F (10 to 99°C)	180°F (82°C)		PIM Identity is H	Piping and application configuration
TARGET MAX.	100°F (38°C) to PIM Operating Limit	XVERS/XVERS L/ XVERS KOR:: 50 to 180°F (10 to 82°C) XPAKFT/XFIIRE/IFIRE Boiler (H): 50 to 192°F (10 to 89°C) Hi DELTA/MVB/XTHERM 50 TO 210°F (10 to 99°C)		Modbus Rate EMS Rate PIM Identity is H	Maximum Target Boiler Temperature
TARGET MIN.	50 to 180°F (10 to 82°C)	50°F (10°C)		Modbus Rate EMS Rate PIM Identity is H	Minimum Target Boiler Temperature
SYS. PURGE	0:20 sec to 20:00 min	0:20 sec		Modbus Temp/Rate PIM DIP = Purge On	Sets the length of the System Pump Purge
UNITS	°F or °C	°F		Always	Show Units Using Icons in Display

When RESET from target screen is selected, the following items will be available for adjustment:

OUT START	35 to 85°F (2 to 30°C)	70°F (21°C)		PIM Identity is H Target = Rset	Outdoor Reset Starting Temperature
OUT DESIGN	-60 to 45°F (-51 to 7°C)	10°F (-12°C)		PIM Identity is H Target = Rset	Outdoor Reset Design Temperature
BOIL START	35 to 150°F (1.5 to 66°C)	70°F (21°C)		PIM Identity is H Target = Rset	Starting Boiler Target Temperature when Outdoor Temperature is at Outdoor Start
BOIL DESIGN	70 to 200°F (21 to 93.5°C)	180°F (82°C)		PIM Identity is H Target = Rset	Design Boiler Target Temperature when the Outdoor Temperature is at Outdoor Design (Hottest Water on Coldest Day)
GLYCOL	0 - 50%	50% XVERS 0% All others		Always	To adjust operation based on fluid being used
WWSD	40 to 100F (4.5 to 38°C)	70F (21°C)		Target = Rset PIM Identity is H	The System Warm Weather Shut Down Temperature

When manual differential is selected via PIM DIP switch 1, the following items will appear.

TARGET DIFF	2 to 42°F (1 to 24°C)	10°F (6°C)		PIM Identity is H DIP = Manual Diff	Differential for Target Boiler Temperature
-------------	--------------------------	---------------	--	--	--

The next items are shown and available for adjustment within the SETUP / ADJUST menu while MODE 3 is selected:					
IND. SENSOR	ON - OFF	OFF		PIM Identity is H MODE = 2 or 3	Selects whether a DHW sensor is used
IND. SETP.	Off, 50 to 180°F (10 to 82°C)	140°F (60°C)		PIM Identity is H MODE = 2 or 3 Ind. Sensor = ON	Target Indirect DHW Temperature. Ind. Sensor is Selected.
IND. DIFF	2 to 10°F (1 to 5.5°C)	6°F (4°C)		PIM Identity is H MODE = 2 or 3 Ind. Sensor = ON	Differential for the target indirect DHW tank Ind. Sensor is Selected
IND. SUPPLY	OFF, 70 to 200°F (21 to 94°C)	180°F (82°C)		PIM Identity is H MODE = 2 or 3 Ind. Sensor = OFF	Target boiler temperature at S6 for the DHW heat exchanger during indirect DHW operation
PRI OVR	Au, 0:10 to 2:00 hr	Au		PIM Identity is H tN4 Bus Detected OR DHW Priority = ON	Sets the length of the priority override time
Item	Range	Default	User Settings	When is it Displayed	Description

The items below correspond to CWP operation. Turn VERSA DIP #3 on to enable CWP.

MIX TYPE	VALVE, PUMP, PLNT	VALVE		H model & CWP DIP = ON	MIX Type assumes that each individual unit will have the proper wiring and pipe configuration to control its own inlet temperature. For H models using a variable speed Pump as a CWP method. See "Cold Water Protection (CWP)" on page 44
MIX TARGET	50 TO 140°F (10 to 60°C)	120°F (49°C)		CWP DIP = ON	Inlet Target Temperature
MIX LOCK	ON / OFF	OFF		CWP DIP = ON	The equipment will trigger a warning when "MIX Target" is not reached within 7-minutes. MIX LOCK = ON Alarm and lockout, MIX LOCK = OFF Alarm only
MIX TRIM	-5 TO 5	0		CWP DIP = ON	This adjustment is for various types and sizes of units as well as various actuator motor speeds and types supplied by factory
MIX SPEED	SLOW, MED, FAST	MED		CWP DIP = ON	This setting defines speed of response
MIX INV	ON / OFF	OFF		CWP DIP = ON	This option is related to the use of spring-return actuators with a proportional 2- or 3-way valve

When communication with BMS is required user must enable Modbus port using the settings below by selecting other than "OFF" at Mode-Modbus screen the following settings will become available.

MODE MODBUS	Off, Monitor, Temp, Rate	Monitor		Always	Modbus Operating Mode: Off, Monitor, Temp Control, Rate Control
ADDRESS	1 to 247	1		Modbus On	Modbus Slave Address (= Node ID). When using Protonode, do not use values over 127 (see Installation Manual P/N 241515)
DATA TYPE	RTU or ASCII	RTU		Modbus On	Modbus Data Type
BAUD RATE	2400, 9600, 19K2, 57K6, 115K	19K2		Modbus On	Communication Speed of Network
PARITY	None, Even, Odd	Even		Modbus On	Error Detection of System Integrator needs this information

Table D. Mode 3 SETUP menu

4.6. Primary Piping Configuration

The VERSA controller can also support a primary piping configuration when using the XVers, XVersL and XVers with KOR product lines. Refer to the XVers manual (241677), XVersL manual (241782) and XVers KOR manual (241849).

4.7. WH Direct DHW Applications

This section covers single- or multiple-heater installations using WH models for use on direct DHW heating systems with or without CWP, used in conjunction with a storage tank at a setpoint not exceeding 160°F (71°C).

The CWP diagrams show both a heater pump as well as a variable-speed pump (MIX Type = Pump). The piping configurations shown apply to both condensing and non-condensing heaters. See **Table E on page 33**.

▲ CAUTION: Continuous pumping through the unit is not supported and may cause a non-warranty failure.

NOTE: For systems requiring temperatures exceeding 160°F (71°C) an "H" model must be used. Use Mode 1 and Manual Differential for this application. Ensure Water hardness does not exceed 15 gpm (60 lpm) to prevent scale formation.

4.7.1. WH - Single

The tank temperature will be controlled by the System Sensor (S3). The tank sensor must be installed in the lower third of the tank using a drywell for proper operation. The VERSA IC will provide Max Delta-T (Differential Temperature) control and will cycle the burner if the Max Delta-T is exceeded between Heater Outlet Sensor (S1) and Heater Inlet Sensor (S2). See **Figure 30**.

In order to enable Cold Water Protection, VERSA DIP #3 must be set to the ON position. The Cold Water Protection system utilizes a variable-flow pumping system to inject just the right amount of water from the main system loop into the heater loop to maintain the optimum inlet temperature as defined in the Installation and Operating manual for the product being installed. See **Figure 31**.

The Heater Pump (P1) runs during any call for burner operation and is delayed "off" as user-defined in the SETUP menu after the burner has shut down. The System Pump output (P2) can be used for the recirculation pump and is enabled to run whenever the heater is enabled for operation. The Heater Pump (P1) runs during any call-for-heat. The Heater Pump (P1) is delayed "off" as user-defined in the BOILER menu.

The System Pump output (P2) is delayed "off" only when the heater is disabled by opening the connection across the enable/disable at the PIM. There is no mode to configure for WH operation, as this is the only mode available as a WH model unit. The Supply Sensor (S3) MUST BE installed in the storage tank and functional for heater operation. See **"System Sensor Installation" on page 11**.

DIP switches #1 and #2 on the VERSA Control Board must be in the ON position to make programming changes. Prior to setting any DIP switches the heater must be turned off.

NOTE: 0-10VDC firing rate control ignores all sensors except S2 and all functions except Max Delta-T, CWP, Limit and Safety Switches.

⚠ CAUTION: Be careful when installing the drywell not to over-tighten the well as this can damage the well and may prevent the sensor from fitting properly.

NOTE: Factory recommends performing a "Screen Reboot" of the touchscreen to ensure all changes display properly. See Section 15.3 on page 72.

4.8. WH - Cascade

This section covers a cascade of up to 8 WH models for use on direct DHW heating systems with and without CWP using a variable-speed pump (MIX Type = Pump), in conjunction with a storage tank. **Figure 32** and **Figure 33** show 4 heaters cascade systems for reference, but these configurations can be expanded up to 8 heater with condensing or non-condensing. The tank temperature will

be controlled by the System Sensor (S3a). The tank sensor must be installed in the lower third of the tank using a drywell for proper operation. See **"System Sensor Installation" on page 11**.

The VERSA IC system will provide Max Delta-T control to cycle the burner if the Max Delta-T is exceeded between Heater Outlet Sensors (S1a-b-c-d) and Heater Inlet Sensors (S2a-b-c-d). In WH mode, the differential setting is below-setpoint only. This is to prevent an overshoot condition from occurring. It is not divided between above- and below-setpoint.

In order to enable Cold Water Protection, VERSA DIP #3 must be set to the ON position. The CWP system utilizes a variable-flow pumping system to inject just the right amount of water from the main system loop into the heater loop to maintain the optimum inlet temperature as defined in the IO manual for the product being installed. The variable-flow pumping system pump will operate in parallel with the pump mounted on the heater.

The Heater Pumps (P1a-b-c-d) run during any call for the associated heater's burner operation and is delayed "off" as user-defined in the BOILER menu after the associated heater burner has shut down. The System Pump output (P2a) can be used for the recirculation pump; it is enabled to run whenever the heater is enabled for operation. The System Pump output (P2a) is delayed "off" only when the heater is disabled by opening the connection across the enable/disable at the Master PIM.

It is recommended the system pump be connected in parallel from each cascade Follower, to allow the system pump to be functional during limp-along operation, if used. If multiple storage tanks are used, plumb to ensure equal flow through each tank and install one system sensor (S3) on one tank only.

There is no mode to configure for WH operation as this is the only mode available as a WH model unit. DIP switches #1 and #2 on the Master VERSA Control Board must be in the ON position to make programming changes. Prior to setting any DIP switches the heater must be turned off. It is important to remember to enable a heater to be a Follower in the cascade by turning DIP switch #2 on the VERSA Control Board to the OFF position for each of the Followers. For Followers equipped with CWP, DIP #3 must be ON.

To enable Follower heaters, scroll to the SETUP menu, scroll to the individual heaters, and toggle from OFF to ON to allow them to operate when commanded by the Master to run. The next menu items are not necessarily in the order in which they will appear. In the case of TN_bus follower units, remember to assign a unique identification number between 5 and 8.

⚠ CAUTION: Be careful when installing the drywell not to over-tighten the well as this can damage the well and may prevent the sensor from fitting properly.

NOTE: Factory recommends performing a "Screen Reboot" of the touchscreen to ensure all changes display properly. See Section 15.3 on page 72.

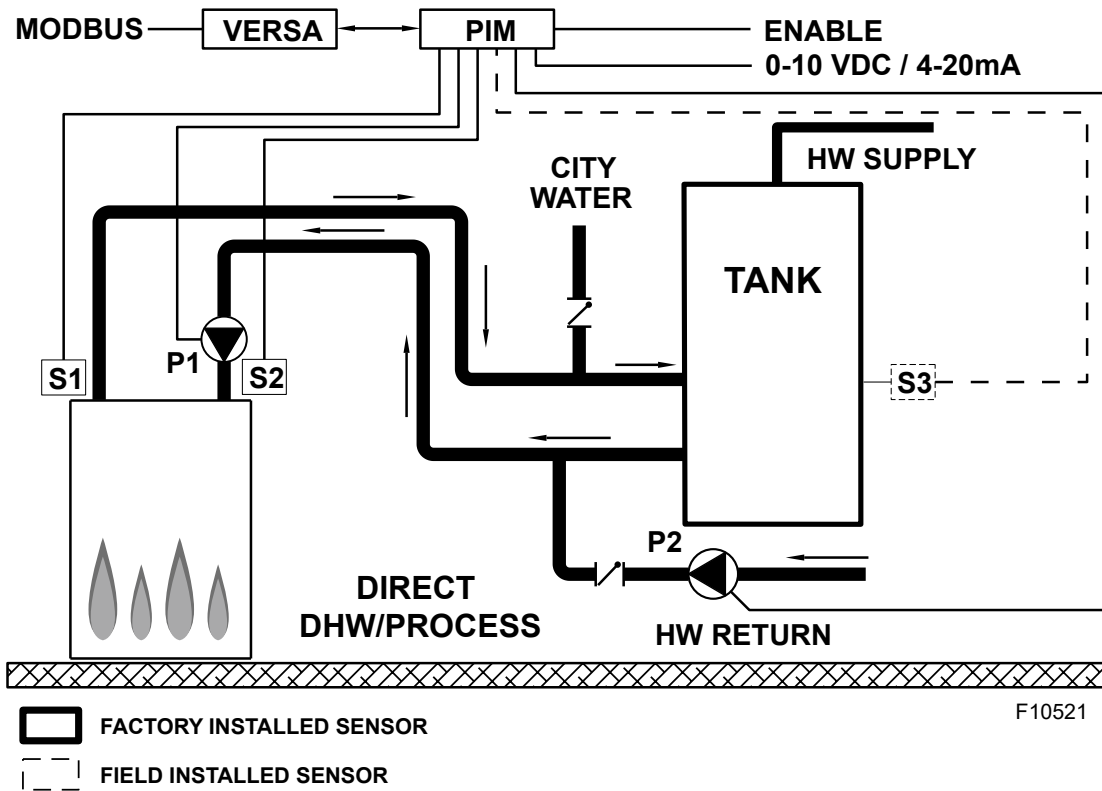

Figure 30. WH Direct DHW - Single Heater

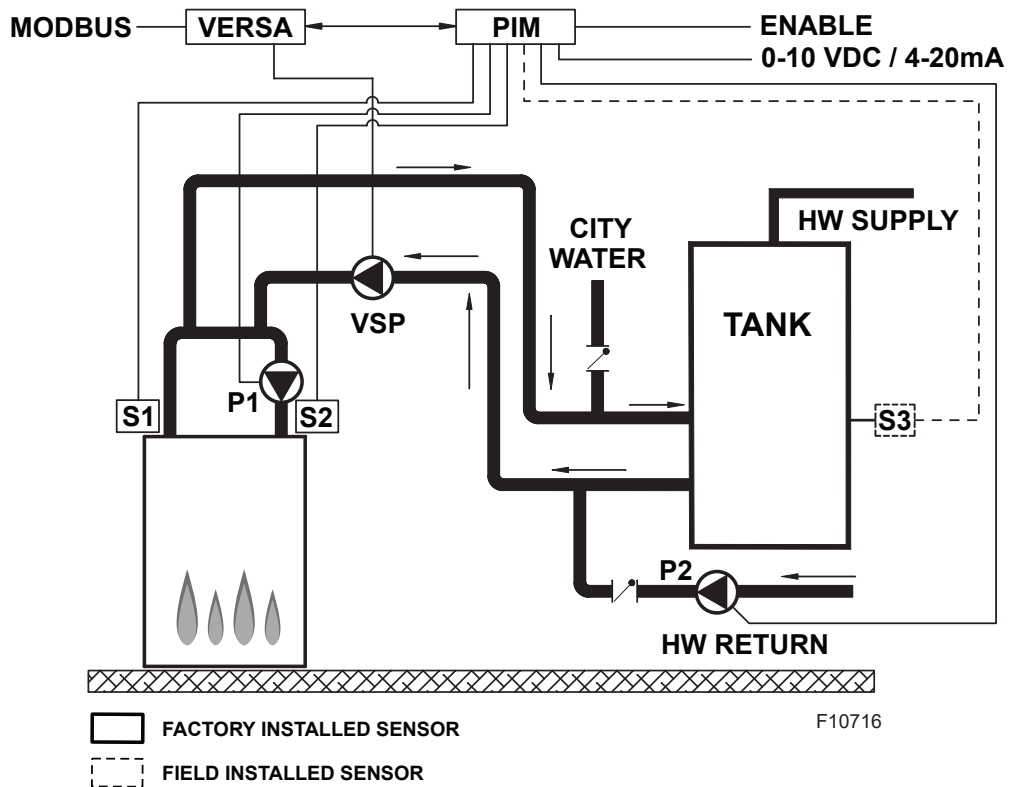

Figure 31. WH Direct DHW - single Heater with CWP (VS Pump - MIX TYPE = PUMP)

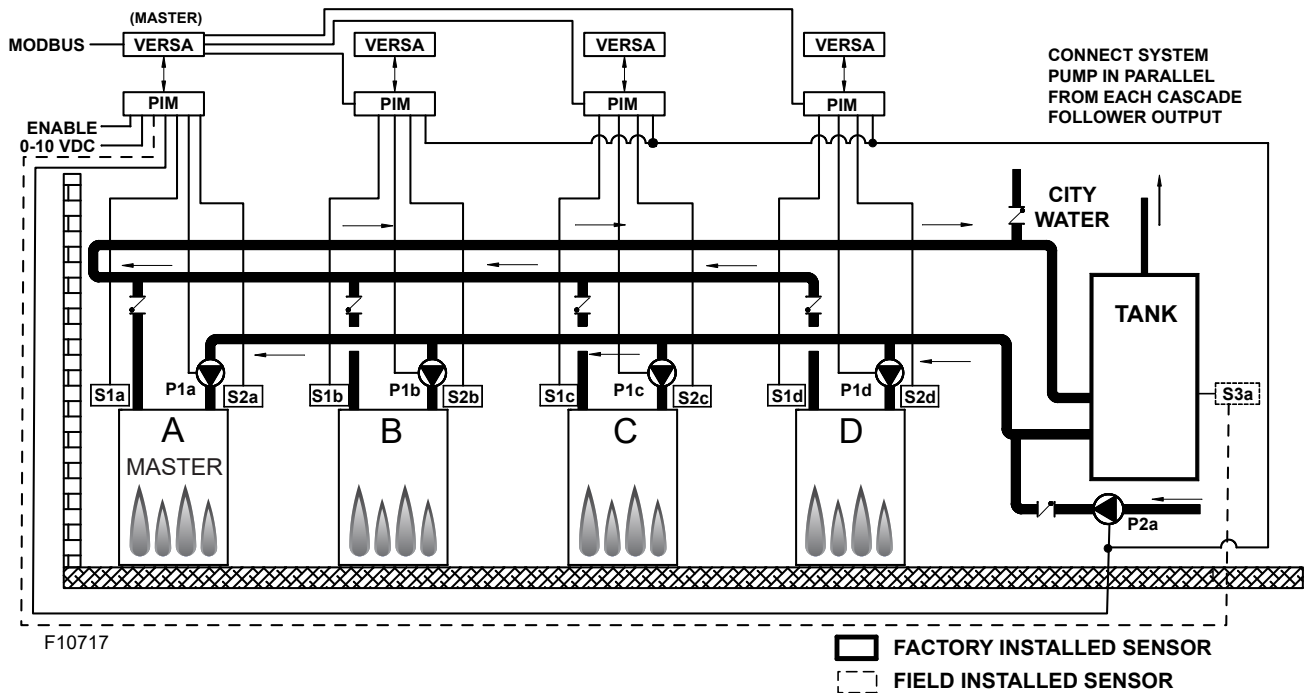

Figure 32. WH Direct DHW Application - Multiple Heaters

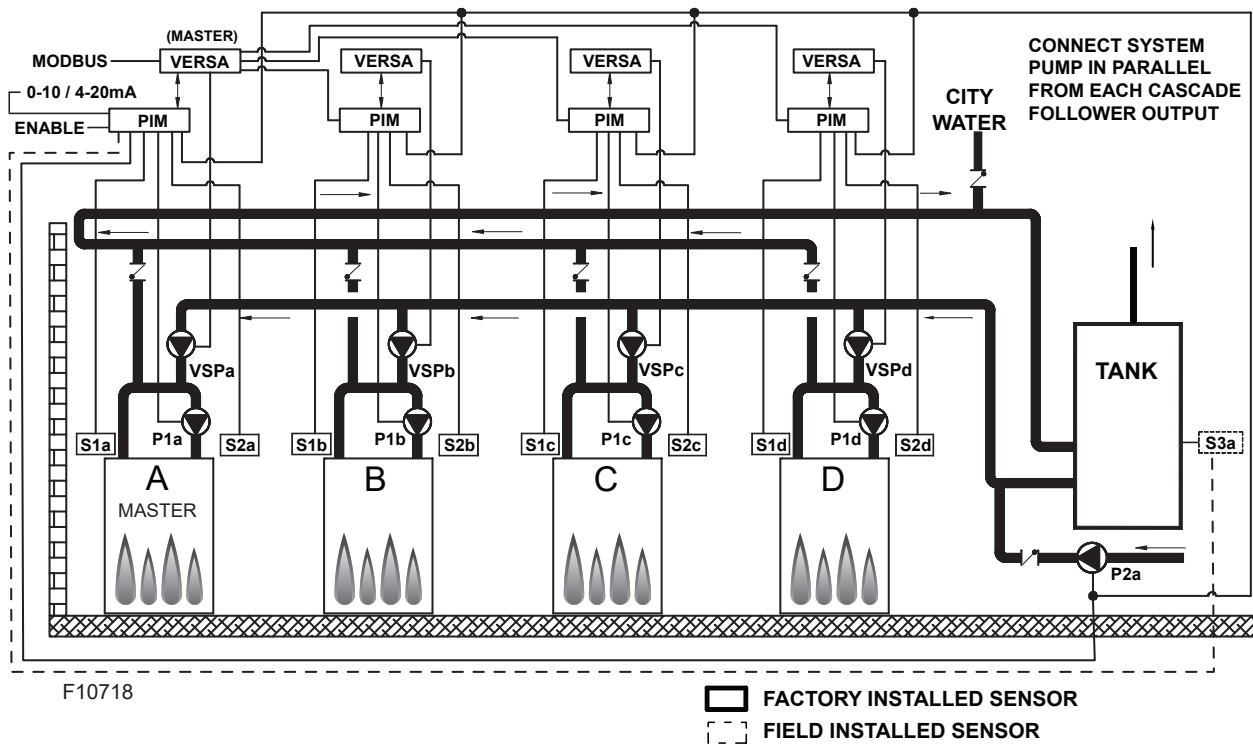

Figure 33. WH Direct DHW Application - Multiple Heaters with CVP (VS Pump)

Enable followers from appropriate BOILER menu at the master:

Item	Range	Default	User Settings	When is it Displayed	Description
BOILER 1, 2, 3, 4	ON <> OFF	OFF		FT_Bus Cascade Followers present	FT_Bus 1, 2, 3, 4 are connected

The following settings are available in the SETUP/ADJUST Menu:

TARGET	EMS Modbus	Not Visible		EMS = Temp/Rate* Modbus = Temp/Rate	EMS = Energy Management System (Analog Target Temperature) MODB = Modbus
TANK SETP	50 to 160°F (10 to 71°C)	125°F (52°C)		PIM Identity is WH	WH Setpoint Temperature
TANK DIFF	2 to 10°F (1 to 6°C)	5°F (3°C)		PIM Identity is WH	WH Differential Temperature
SYS. PURGE	OFF, 0:20 sec to 20:00 min	0:20 min		Modbus Temp/Rate PIM DIP = Purge On	Sets the length of the System Pump Purge
UNITS	°F or °C	°F		Always	Show Units Using Icons in Display

The items below correspond to CWP operation. Ensure VERSA DIP #3 is ON to enable CWP:

MIX TYPE	VALVE/PUMP	PUMP		PIM Identity is WH CWP DIP = ON	MIX Type assumes that each individual unit will have the proper wiring and pipe configuration to control its own inlet temperature
MIX TARGET	50 to 140°F (10 to 60°C)	120°F (49°C)		CWP DIP = ON	Inlet Target Temperature
MIX LOCK	ON / OFF	OFF		CWP DIP = ON	The equipment will trigger a warning when "MIX Target" is not reached within 7-minutes. MIX LOCK = ON Alarm and lockout, MIX LOCK = OFF Alarm only
MIX TRIM	-5 to 5	0		CWP DIP = ON	This adjustment is for various types and sizes of units as well as various actuator motor speeds and types supplied by factory
MIX SPEED	SLOW, MED,FAST	MED		CWP DIP = ON	This setting defines speed of response
MIX INV	ON / OFF	OFF		CWP DIP = ON	This option is related to the use of spring-return actuators with a proportional 2 or 3-way valve

When communication with BMS is required user must enable Modbus port using the settings below by selecting other than "OFF" at Mode-Modbus screen the following settings will become available.

MODE MODBUS	Off, Monitor, Temp, Rate	Monitor		Always	Modbus Operating Mode: Off, Monitor, Temp Control, Rate Control
ADDRESS	1 to 247	1		Modbus On	Modbus Slave Address (= Node ID). When using Protonode, do not use values over 127 (see Installation Manual P/N 241515)
DATA TYPE	RTU or ASCII	RTU		Modbus On	Modbus Data Type
BAUD RATE	2400, 9600, 19K2, 57K6, 115K	19K2		Modbus On	Communication Speed of Network
PARITY	None, Even, Odd	Even		Modbus On	Error Detection of System. Integrator needs this information

*Direct drive from the EMS (PIM DIP switch 2 = ON) applies only to a single unit. Target temp (PIM DIP 2 = OFF) can be used for either a single unit or cascade.

For detailed information see "**MODBUS PROTOCOL**" on page 73.

Table E. WH applications SETUP menu

4.9. Pool – Heater Applications

4.9.1. Single Unit

This section covers single- or multiple-heater installations using P models for use on direct Pool Water heating systems with or without CWP. Primary/secondary piping is the only method supported by the factory to ensure proper heater and system functionality while achieving

maximum system efficiency. **Figure 34** through **Figure 36** represent condensing and non-condensing heaters. The CWP diagrams show both a heater pump and a variable-flow pumping system. See **Table F** on page 37.

⚠ CAUTION: Continuous pumping through the unit is not supported and may cause a non-warrantable failure.

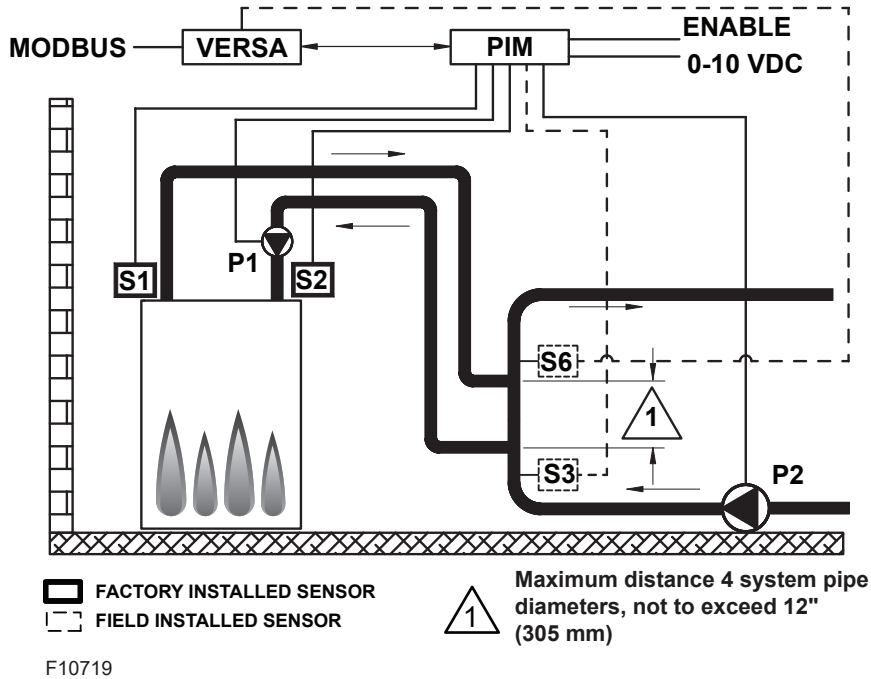

Figure 34. Pool Single Condensing Heater application

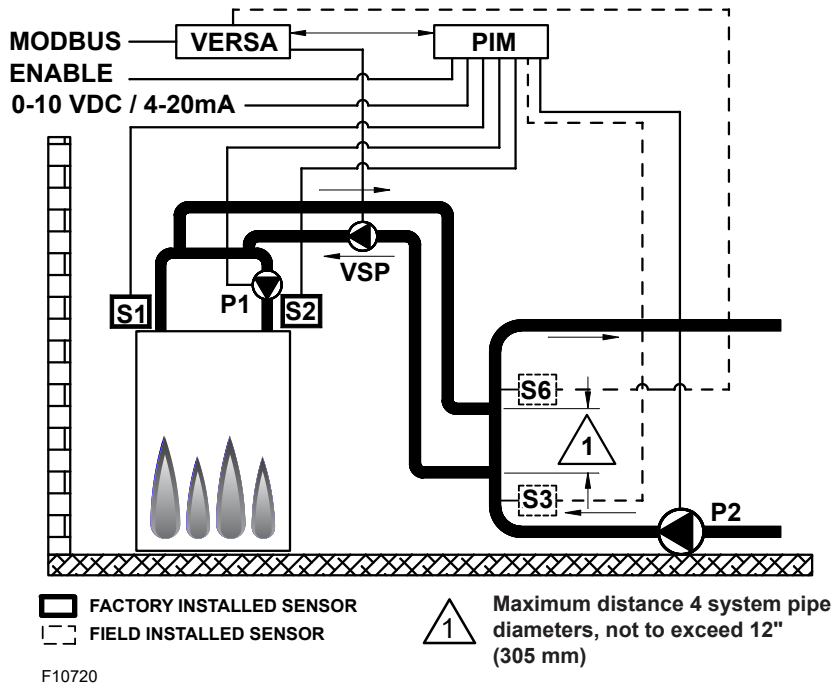

Figure 35. Pool Single Heater with CWP (VS Pump)

The pool temperature will be controlled by the System Sensor (S3). The VERSA IC will provide Max Return protection control using the Pool Return Sensor (S6) and will cycle the burner if the return to the pool exceeds the Max Return setting. Both the System (S3) and Pool Return (S6) sensors must be installed using drywells and fully immersed into the flow path for proper operation. See **"System Sensor Installation"** on page 11. Max Delta-T (Differential Temperature) control is also provided and will cycle the burner if the Max Delta-T is exceeded between Heater Outlet Sensor (S1) and Heater Inlet Sensor (S2).

In order to enable CWP, VERSA DIP #3 must be set to the ON position. The CWP system utilizes a variable-flow pumping system to inject just the right amount of water from the main system loop into the boiler loop to maintain the optimum inlet temperature as defined in the Installation and Operation Manual for the product being installed. The variable-flow pumping system will operate in parallel with the unit-mounted heater pump.

The Heater Pump (P1) runs during any call for burner operation and is delayed "off" after the burner has shut down as user-defined in the SETUP menu. The System Pump output (P2) is available to drive the filter pump and enabled to run whenever the heater is enabled for operation. The Heater Pump (P1) runs during any call-for-heat. The Heater Pump (P1) is delayed "off" as user-defined in the BOILER menu. The System Pump output (P2) is delayed "off" only when the heater is disabled by opening the connection across the enable/disable at the PIM.

There is no mode to configure for Pool operation as this is the only mode available as a P model unit.

DIP switches #1 and #2 on the VERSA Control Board must be in the ON position to make programming changes. Prior to setting any DIP switches, the heater must be turned off. The Differential setting applies below-setpoint only. This is to prevent overshoot condition from occurring.

NOTE: 0-10VDC firing rate control ignores all sensors except S2 and all functions except Max Delta-T, CWP, Limit and Safety Switches.

NOTE: Factory recommends performing a "Screen Reboot" of the touchscreen to ensure all changes display properly. See Section 15.3 on page 72 .

4.9.2. Pool – Cascade

Figure 36 and Figure 37 show 4 heaters (P Model) cascade systems for reference, but these configurations can be expanded up to 8 heaters (P Model) for use on direct Pool Water heating systems with and without CWP using a variable-flow pumping system. Reverse/return piping is shown and is recommended to ensure balanced flow through each of the connected units.

Primary/secondary logic is the only method supported by factory to ensure proper heater and system functionality while achieving maximum system efficiency. The following configurations are representative of a cascade of condensing or non-condensing heaters with CWP provided by a variable-flow pumping system.

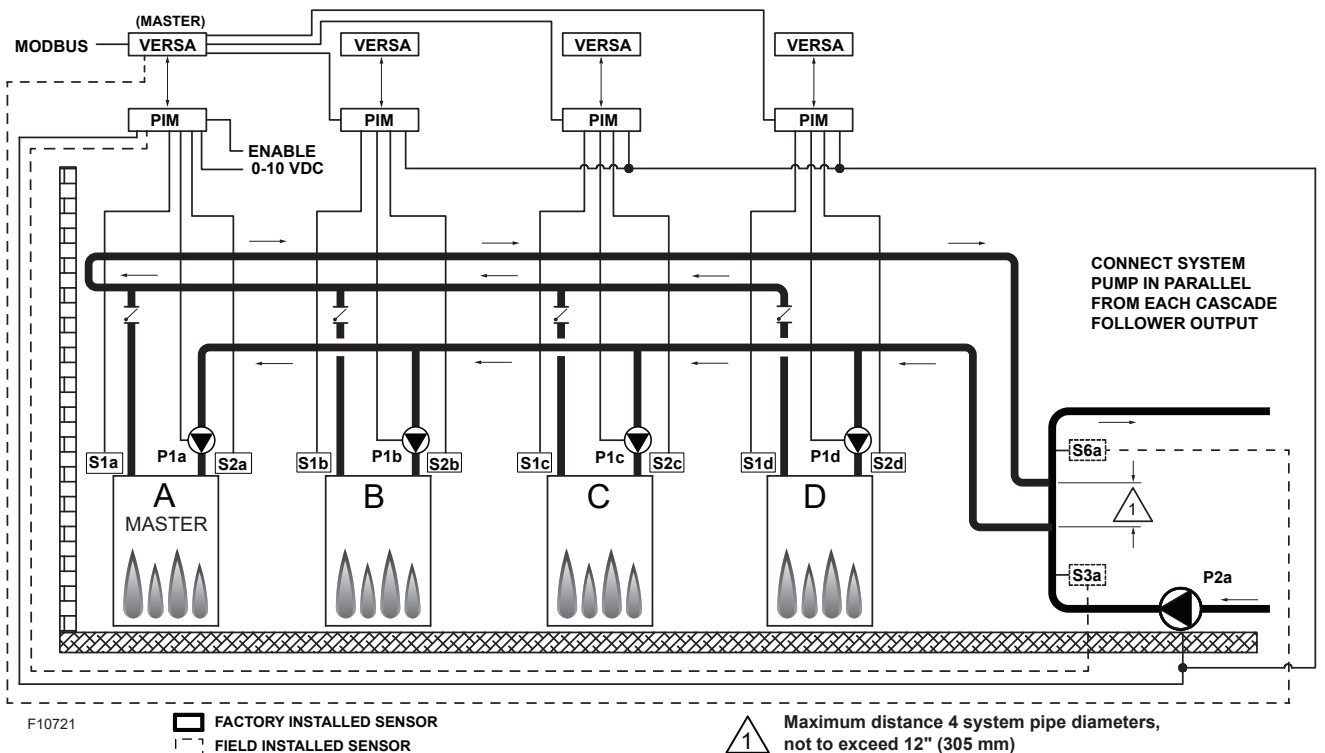

Figure 36. Pool Multiple Condensing Heaters Cascade

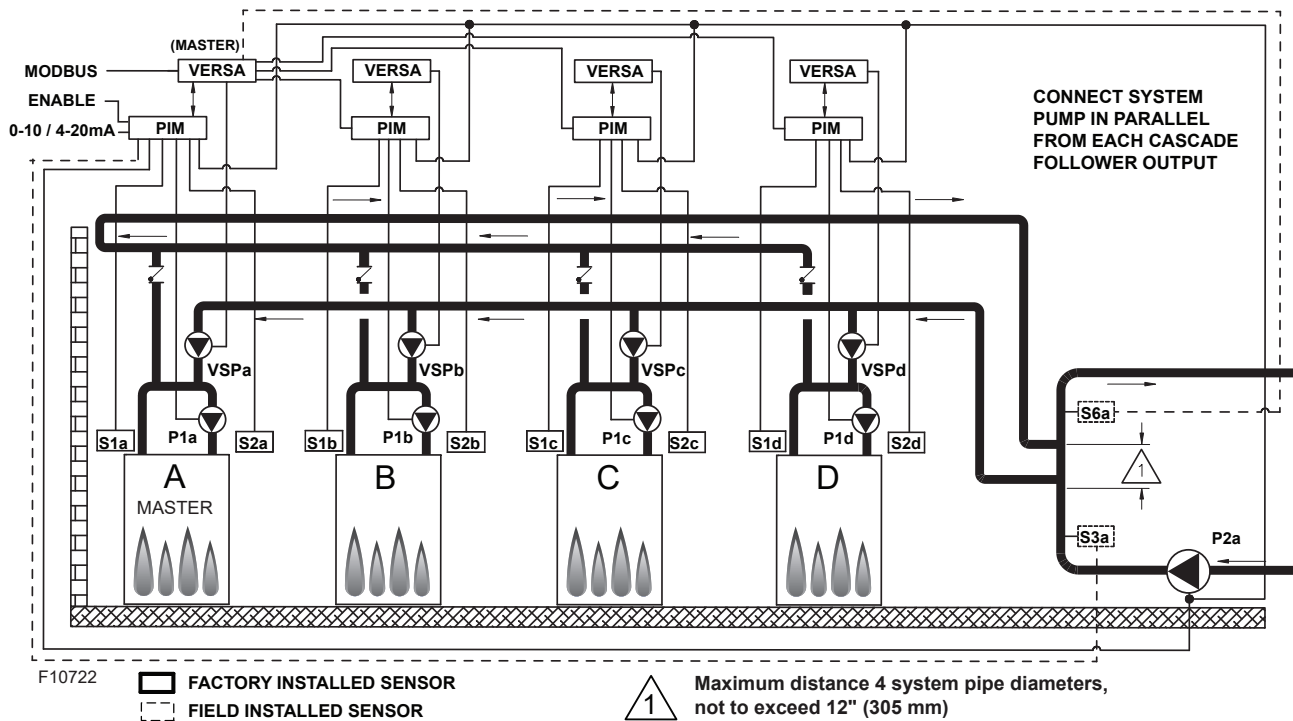

Figure 37. Pool Multiple Heaters Cascade with CWP (VS Pump)

The pool temperature will be controlled by the System Sensor (S3a). The VERSA IC will provide Max Return protection control using the Pool Return Sensor (S6a) and will cycle the burner(s) if the return to the pool exceeds the Max Return setting.

Both the System (S3a), and Pool Return (S6a) sensors must be installed using a drywell and fully immersed into the flow path for proper operation. See **"System Sensor Installation"** on page 11. The system will provide Max Delta-T control to cycle the burner to ensure that the Delta-T is not exceeded between Heater Outlet Sensors (S1a-b-c-d) and Heater Inlet Sensors (S2a-b-c-d).

In order to enable CWP, VERSA DIP #3 must be set to the ON position. The Cold Water Protection system utilizes a variable-flow pumping system pump to inject just the right amount of water from the main system loop into the boiler loop to maintain the optimum inlet temperature (S2 a-b-c-d), among all active units, as defined in the Installation and Operating manual for the product being installed. The variable-flow pumping system will operate in parallel with the unit-mounted heater pump.

The Boiler Pumps (P1a-b-c-d) run during any call for that associated heater's burner and is delayed "off" after the associated boiler's burner has shut down as user-defined in the BOILER menu. The System Pump (P2a) runs whenever the system is enabled for heating. The System Pump is delayed "off" as user-defined in the SETUP menu. It is recommended the System Pump be connected in parallel from each cascade Follower, to allow the System Pump to be functional during "limp-along" operation if this output is used to operate the filtration pump.

The Supply (S3a) and Pool Return Sensor (S6a) connect to the Master. Each heater in the cascade connects to and controls its own respective Boiler Pump (P1a-b-c-d). The System Pump (P2a) gets its enable signal from the Master. It is important to remember to enable a heater to be a Follower in the cascade by turning DIP switch #2 on the VERSA Control Board to the OFF position for each of the Followers. Once the Followers have been configured correctly you must then enable the Followers within the appropriate BOILER menu at the Master by turning them from OFF to ON, Master DIP #2 must remain on. See BOILER menu items in **Table D**. This configuration supports EMS 0-10 VDC input for temperature control (in rate mode, any firing rate drives the heater to 100%) and can be configured for connectivity to BMS via the on-board Modbus port covered later in this manual.

There is no mode to configure for Pool operation as this is the only mode available as a P model unit. DIP switches #1 and 2 on the Master VERSA Control Board must be in the ON position to make programming changes. Prior to setting any DIP switches, the heater must be turned off. The differential setting applies below-setpoint only. This is to prevent an overshoot condition from occurring. The next menu items are not necessarily in the order in which they will appear.

NOTE: Factory recommends performing a "Screen Reboot" of the touchscreen to ensure all changes display properly. See Section 15.3 on page 72.

Enable followers from appropriate BOILER menu at the master:

Item	Range	Default	User Settings	When is it Displayed	Description
BOILER 1, 2, 3, 4	ON <> OFF	OFF		FT_Bus Cascade Followers present	FT_Bus 1, 2, 3, 4 are connected

The following settings are available in the SETUP/ADJUST Menu:

TARGET	EMS Modbus	Not Visible		*EMS = Temp/Rate Modbus = Temp/Rate	EMS = Energy Management System (Analog Target Temperature) MODB = Modbus
POOL SETP	50 to 104°F, 106°F (10 to 41°C)	80°F (26.5°C)		PIM Identity is P	Pool Setpoint Temperature
POOL DIFF	1 to 5°F (0.5 to 3°C)	2°F (1°C)		PIM Identity is P	Pool Differential Temperature
POOL MAX	110 to 120°F (43.5 to 49°C)	110°F (43.5°C)		PIM Identity is P	MAX Supply Temperature to Pool
SYS. PURGE	OFF, 0:20 sec to 20:00 min	0:20 sec		*Modbus Temp/Rate PIM DIP = Purge On	Sets the length of the System Pump Purge
UNITS	°F or °C	°F		Always	Show Units Using Icons in Display

The items below correspond to CWP operation. Ensure VERSA DIP #3 is ON to enable CWP:

MIX TARGET	50 to 140°F (10 to 60°C)	120°F (49°C)		CWP DIP = ON	Inlet Target Temperature
MIX LOCK	ON / OFF	OFF		CWP DIP = ON	The equipment will trigger a warning when "MIX Target" is not reached within 7-minutes. MIX LOCK = ON Alarm and lockout, MIX LOCK = OFF Alarm only
MIX TRIM	-5 to 5	0		CWP DIP = ON	This adjustment is for various types and sizes of units as well as various actuator motor speeds and types supplied by factory
MIX SPEED	SLOW, MED, FAST	MED		CWP DIP = ON	This setting defines speed of response.
MIX INV	ON / OFF	OFF		CWP DIP = ON	This option is related to the use of spring-return actuators with a proportional 2- or 3-way valve

When communication with BMS is required user must enable Modbus port using the settings below by selecting other than "OFF" at Mode-Modbus screen the following settings will become available.

MODE MODBUS	Off, Monitor, Temp, Rate	Monitor		Always	Modbus Operating Mode: Off, Monitor, Temp Control, Rate Control
ADDRESS	1 to 247	1		Modbus On	Modbus Slave Address (= Node ID). When using Protonode, do not use values over 127 (see Installation Manual P/N 241515)
DATA TYPE	RTU or ASCII	RTU		Modbus On	Modbus Data Type
BAUD RATE	2400, 9600, 19K2, 57K6, 115K	19K2		Modbus On	Communication Speed of Network
PARITY	None, Even, Odd	Even		Modbus On	Error Detection of System. Integrator needs this information

*Direct drive from the EMS (PIM DIP 2 = ON) applies to a single unit only. Target temp (PIM DIP 2 = OFF) can be used for either a single unit or cascade.

For detailed information see **"MODBUS PROTOCOL" on page 73.**

Table F. Pool Applications Setup Menu

5. VERSA IC MENUS

The LCD and Touchscreen user interface consists of several Menu options. The following will describe the LCD user interface.

Press the MENU button to scroll through the different menus in the interface. Press the ITEM button to select a specific menu to scroll through available items within a selected menu. The UP and DOWN buttons allow for setting changes to items in the SETUP menu. The available menus are VIEW, SETUP, BOILER, MONITOR, and TOOLBOX. The RESET button is used to reset the control when a hard lockout condition has occurred. See specific heater Installation and Operation Manual for instructions regarding resetting the control.

5.1. User Interface Menus

The VIEW, BOILER, MONITOR, and TOOLBOX menus are available in the control. See **Table G** through J.

Press the MENU button on the membrane switch, then press the ITEM button to scroll through the menus. Some menu items are model-specific and not available on all equipment types.

5.2. VIEW Menu

The “VIEW” icon is turned on. BOILER and 1 segment are turned on if BOILER 2, 3, or 4 are set to ON.

Item	When is it Displayed	Description
OUTDOOR	MASTER PIM Identity is H TARGET = RSET	Outdoor air temperature. The number field displays “----” if the OUTDOOR sensor has a fault
TARGET	MASTER MODBUS RATE EMS RATE	Current target water temperature. The number field displays “----” when there is no current target.
POOL	PIM identity is P	Current pool temperature. The number field displays “----” if the pool sensor fails
TANK	PIM identity is WH	Current tank temperature. The number field displays “----” if the Tank sensor fails
SUPPLY	MASTER	Current system supply temperature. The number field displays “----” if the SUPPLY sensor has a fault
IND SUPPLY	PIM Identity is H, MODE = 2 or 3	Current temperature being supplied to the indirect. The number field displays “----” if the indirect DHW sensor fails. Sensed at S3 for mode 2, at S6 for mode 3
BOIL OUTLET	Always	Current boiler outlet temperature as communicated from the PIM. The number field displays “----” if the outlet sensor fails. Sensed at S1 for mode 1, S3 for mode 2, S6 for mode 3.
BOIL INLET	Always	Current boiler inlet temperature as communicated from the PIM. The number field displays “----” if the inlet sensor fails
BOIL ΔT	Always	Current temperature difference between the boiler outlet and boiler inlet. The number field displays “----” if the inlet and/or outlet sensor fails
DHW SUPPLY	MASTER PIM Identity is H, MODE = 2 OR 3 DHW SENSOR = ON	Current Indirect DHW Supply temperature. The number field displays “----” if the DHW sensor has a fault
BOILER 1	MASTER	Shows the operation status of master boiler. IDLE, POST, PREP, MOD%, STG 1, SOFT, HARD
BOILER 2, 3, 4	MASTER	Shows the operation status of FT_bus follower boilers in cascade. IDLE, POST, PREP, MOD%, STG 1, SOFT, HARD
FOLLOWERS	MASTER	Shows the number of followers in cascade operation

Table G. View Menu

5.2.1. BOILER View Menu

The “BOILER 1” icon is turned on. Boiler 1, 2, 3 or 4 are displayed for their respective boilers.

Item	Display	User Settings	When is it Displayed	Description
BOILER 1	ON < > OFF		Always	Enables Boiler for operation
BOILER 2	ON < > OFF		FT_Bus 2 is connected	Enables Boiler for cascade operation
BOILER 3	ON < > OFF		FT_Bus 3 is connected	Enables Boiler for cascade operation
BOILER 4	ON < > OFF		FT_Bus 4 is connected	Enables Boiler for cascade operation
CASCADE	OFF < > 5 < > 6 < > 7 < > 8		TN_Bus Follower Unit	TN_Bus Address for Current Follower
VENT TYPE	PVC < > PPS < > CPVC < > SS		PIM is Firetube	Select Vent type. Any option different than SS requires Vent Sensor
VENT DIFF	1 - 20°F (1 - 11°C)		PIM is Firetube	Temperature differential for Vent
VENT HOLD	10 - 100%		PIM is Firetube	Define fire rate when Vent differential temperature is reached
IGNITION 1, IGNITION 2	IDLE, PREP, IGN, BURN, POST, HARD, SOFT STG 1, 2, 3, 4	N/A	Always	IDLE=no CFH PREP=pre-purge or inter-purge between trials for ignition IGN=trial for ignition BURN=burner operating POST=post purge HARD=a hard lockout fault has occurred requiring manual-reset (Ignition Lockout or manual high limit) SOFT=a soft lockout fault has occurred which interrupts the heating cycle (any safety other than ignition or manual high limit) The CFH will resume after the soft lockout fault has been corrected and a 15 min. waiting period has expired
VENT WALL	16 - 300°F (-9 - 149°C)		PIM is Firetube	Vent Temperature
LIMIT TEMP	H 200-240°F (94-116°C) WH 180-200°F (82-94°C) P 180°F (82°C)	N/A	Always	Current Outlet -Limit temperature, set by PIM. Max set by ID Card
EMS VDC	VDC	N/A	Always	Current EMS signal in Volts DC
FIRE RATE	%	N/A	Always	PIM firing rate
SPEEDX 1000	RPM	N/A	PIM Identity Modulating	Blower speed in revolutions per minute (rpm) x 1000, set by PIM
OUTLET MAX	°F or °C		PIM identity =H	Defines max outlet temperature offset above target setpoint (press and hold up and down arrows for 3-seconds to enable adjustment)
OPERATOR	°F or °C		Always	Operator Potentiometer setting on PIM
DIFF	°F or °C	N/A	PIM Differential DIP set to Auto	Current auto differential – Fixed by PIM
BOIL PURGE	min		PIM DIP = purge	Sets the length of the boiler pump purge.
FLAME CUR	Amp	N/A	Always	Flame current in micro-amps (µA)
MASS	1 < > 2		PIM Identity = H	Thermal mass recovery
IDENTITY	H, WH, P	N/A	Always	Identifies the unit as boiler, water heater or pool heater
IGN TYPE	HSI, DSI	N/A	Always	PIM Board type
ID CARD		N/A	Always	Identity Card for PIM

Table H. Boiler Menu

5.2.2. MONITOR Menu

The “MONITOR” icon is turned on.

Item	Display	When is it Displayed	Description
RUN TIME BURNER	hrs	Always	Burner runtime (hours). Press UP & DOWN buttons for 3-sec to clear this entry
CYCLES BURNER	0 to 9999	Always	Number of boiler cycles. Press UP & DOWN buttons for 3-sec to clear this entry
RUN TIME PUMPS – BOILER	hrs	Always	Boiler pump runtime (hours). Press UP & DOWN buttons for 3-sec to clear this entry
RUN TIME PUMPS – SYSTEM	hrs	Always	System pump runtime (hours). Press UP & DOWN buttons for 3-sec to clear this entry
RUN TIME PUMPS – DHW	hrs	MODBUS TEMP/RATE EMS TEMP/RATE PIM Identity is H, MODE = 2 or 3	DHW pump runtime (hours). Press UP & DOWN buttons for 3-sec to clear this entry
OUTLET HI	°F or °C	Always	Captures the highest Boiler Outlet Temperature recorded. Press UP & DOWN buttons for 3-sec to clear this entry
OUTLET LO	°F or °C	Always	Captures the lowest Boiler Outlet Temperature recorded. Press UP & DOWN buttons for 3-sec to clear this entry
INLET HI	°F or °C	Always	Captures the highest Boiler Inlet Temperature recorded. Press UP & DOWN buttons for 3-sec to clear this entry
INLET LO	°F or °C	Always	Captures the lowest Boiler Inlet Temperature recorded. Press UP & DOWN buttons for 3-sec to clear this entry
DELTA HI	°F or °C	Always	Captures the highest Delta-T Temperature recorded. Press UP & DOWN buttons for 3-sec to clear this entry
OUTDOOR HI	°F or °C	MASTER MODBUS TEMP/RATE EMS TEMP/RATE PIM Identity is H TARGET = RSET	Captures the highest Outdoor Temperature recorded. Press UP & DOWN buttons for 3-sec to clear this entry
OUTDOOR LO	°F or °C	MASTER MODBUS TEMP/RATE EMS TEMP/RATE PIM Identity is H TARGET = RSET	Captures the lowest Outdoor Temperature recorded. Press UP & DOWN buttons for 3-sec to clear this entry
SYS HI	°F or °C	MASTER MODBUS RATE EMS RATE PIM Identity is H or P	Captures the highest System Supply Temperature recorded. Press UP & DOWN buttons for 3-sec to clear this entry
SYS LO	°F or °C	MASTER MODBUS RATE EMS RATE PIM Identity is H or P	Captures the lowest System Supply Temperature recorded. Press UP & DOWN buttons for 3-sec to clear this entry
DHW HI	°F or °C	MASTER MODBUS TEMP/RATE EMS TEMP/RATE PIM Identity is H, MODE = 2 or 3 DHW SENS = ON	Captures the highest indirect DHW Temperature recorded. Press UP & DOWN buttons for 3-sec to clear this entry
DHW LO	°F or °C	MASTER MODBUS TEMP/RATE EMS TEMP/RATE PIM Identity is H, MODE = 2 or 3 DHW SENS = ON	Captures the lowest indirect DHW Temperature recorded. Press UP & DOWN buttons for 3-sec to clear this entry
TANK HI	°F or °C	MASTER MODBUS TEMP/RATE EMS TEMP/RATE PIM Identity is WH	Captures the highest Tank Temperature recorded. Press UP & DOWN buttons for 3-sec to clear this entry
TANK LO	°F or °C	MASTER MODBUS TEMP/RATE EMS TEMP/RATE PIM Identity is WH	Captures the lowest Tank Temperature recorded. Press UP & DOWN buttons for 3-sec to clear this entry
POOL HI	°F or °C	MASTER MODBUS TEMP/RATE EMS TEMP/RATE PIM Identity is P	Captures the highest Pool Temperature recorded. Press UP & DOWN buttons for 3-sec to clear this entry
POOL LO	°F or °C	MASTER MODBUS TEMP/RATE EMS TEMP/RATE PIM Identity is P	Captures the lowest Pool Temperature recorded. Press UP & DOWN buttons for 3-sec to clear this entry

Table I. Monitor Menu

5.2.3. TOOLBOX Menu

The “TOOLBOX” icon is turned on.

Item	Display	Default	When is it Displayed	Description
Lookup Active Error			Active Error Present	Lookup and display the active error information
USER TEST	OFF <> ON	OFF	Advanced	Select ON to start the function, setting returns to OFF after running the test.
MAX HEAT	OFF <> ON	OFF	Advanced	Select ON to start the function, the setting will time out to OFF after 24 hrs or can be set to OFF again by the user
SW	SW_J1214 (JXX <> XXA)		Always	Software number of VERSA IC Control. The number field alternates between SW_J1214 and Jxx <> xxA when the item is entered
DEFAULTS	----		Always	Press UP and DOWN for 3-seconds to show CLR and load factory defaults to all settings. Does not clear the fault history
tN4 Menu			Always	Large Number: Bandwidth Used % Burner Number: Dropped Message % Mixing Number: Congestion Detected %
HISTORY-1 <->			Logged error present	Alternate “HISTORY 1” with lookup and display the most recent error information if less than 30 days old. Press UP and DOWN buttons for 3-sec to clear this entry
HISTORY-2 <->			Logged error present	Alternate “HISTORY 2” with lookup and display the most recent error information if less than 30 days old. Press UP and DOWN buttons for 3-sec to clear this entry
HISTORY-3 <->			Logged error present	Alternate “HISTORY 3” with lookup and display the most recent error information if less than 30 days old. Press UP and DOWN buttons for 3-sec to clear this entry
HISTORY-4 <->			Logged error present	Alternate “HISTORY 4” with lookup and display the most recent error information if less than 30 days old. Press UP and DOWN buttons for 3-sec to clear this entry
HISTORY-5 <->			Logged error present	Alternate “HISTORY 5” with lookup and display the most recent error information if less than 30 days old. Press UP and DOWN buttons for 3-sec to clear this entry
HISTORY-6 <->			Logged error present	Alternate “HISTORY 6” with lookup and display the most recent error information if less than 30 days old. Press UP and DOWN buttons for 3-sec to clear this entry
HISTORY-7 <->			Logged error present	Alternate “HISTORY 7” with lookup and display the most recent error information if less than 30 days old. Press UP and DOWN buttons for 3-sec to clear this entry
HISTORY-8 <->			Logged error present	Alternate “HISTORY 8” with lookup and display the most recent error information if less than 30 days old. Press UP and DOWN buttons for 3-sec to clear this entry
HISTORY-9 <->			Logged error present	Alternate “HISTORY 9” with lookup and display the most recent error information if less than 30 days old. Press UP & DOWN buttons for 3-sec to clear this entry
HISTORY-10 <->			Logged error present	Alternate “HISTORY 10” with lookup and display the most recent error information if less than 30 days old. Press UP and DOWN buttons for 3-sec to clear this entry
HISTORY-11<->			Logged error present	Alternate “HISTORY 11” with lookup and display the most recent error information if less than 30 days old. Press UP and DOWN buttons for 3-sec to clear this entry
HISTORY-12<->			Logged error present	Alternate “HISTORY 12” with lookup and display the most recent error information if less than 30 days old. Press UP and DOWN buttons for 3-sec to clear this entry
HISTORY-13<->			Logged error present	Alternate “HISTORY 13” with lookup and display the most recent error information if less than 30 days old. Press UP and DOWN buttons for 3-sec to clear this entry
HISTORY-14<->			Logged error present	Alternate “HISTORY 14” with lookup and display the most recent error information if less than 30 days old. Press UP and DOWN buttons for 3-sec to clear this entry
HISTORY-15<->			Logged error present	Alternate “HISTORY 15” with lookup and display the most recent error information if less than 30 days old. Press UP and DOWN buttons for 3-sec to clear this entry

Table J. Toolbox Menu

6. CONTROL SETTINGS

6.1. Boiler System (BOILER 1, 2, 3, 4)

These settings inform the control how many units are part of a cascaded system connected through FT_Bus. Each heater in the cascade must have this setting adjusted to ON to be recognized. For units connected through TN bus must have "Cascade" setting defined as either 5-8. FT_Bus units must have "Cascade" setting defined as "OFF". In addition, DIP switch #2 on the MASTER heater VERSA Control Board must be set to "ON" (Master) while the same DIP switch for the remaining heaters must be set to OFF (Follower). Connections between the additional heaters must be made between the respective heater PIM and the Master heater VERSA Control Board. See **"VERSA IC Connections" on page 55.**

NOTE: During service or if it is determined that a heater should NOT be operational, this value can be set to OFF to disable a heater so the system will not use it or calculate it in the system operation. If the MASTER unit needs to be powered off, the system will allow functionality through the followers by using limp-along mode. To allow proper functionality, the system pump and DHW pump (if applicable) must be connected as depicted on Figure 45 and Figure 46 on page 56.

6.2. Outlet Max

The VERSA IC Control Board uses this function in an attempt to prevent an over-temperature condition from occurring in hydronic systems. The Outlet Max value will anticipate a rapid temperature increase at the outlet sensor and force the system to modulate down before such an event occurs. This setting has an adjustable range of 20 to 70°F (11 to 39°C) above the Target value. The minimum value for the resulting High Outlet Limit will always be 170°F (77°C), regardless of the Target value. The resulting value defines the High Outlet temperature and the unit will start modulating 20°F (11°C) below this value.

6.3. Minimum Modulation Setting

This setting is applicable only for modulating H and some WH models. This setting is used to override the PIM minimum modulation value, up to 60%, and is located within the local boiler page as shown below. For each model, the PIM has a minimum modulation rate allowed.

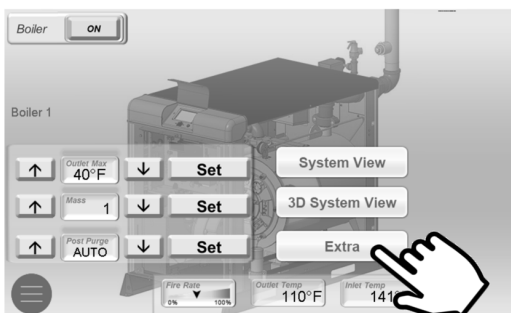

Figure 38. Minimum Mod Setting Interface

⚠ WARNING: Any modification of the Minimum Mod Setting must be done in conjunction with a flue gas analyzer to ensure the CO and CO2 levels are within range as specified in the product manual.

6.4. Target Configuration (TARGET)

This setting is used to define if the control will operate based on Outdoor Air Reset (RSET), setpoint control (SETP), or an Energy Management System through the ModBus communication protocol (MODB). The default setting is SETP.

6.5. Mode Selection (MODE)

This MODE selection determines the operational characteristics of the system.

MODE = 1 relates to hydronic heating or process heating applications.

MODE = 2 relates to conventional heating with an indirect heating need located in the system loop piping.

MODE = 3 relates to conventional heating with an indirect heating needs located within the boiler loop piping. See **"APPLICATIONS AND MODES" on page 12** for more details of how your specific system should be configured.

WH and P models have no other selectable modes available to them.

6.6. Setpoint Temperature (SETPOINT)

This is the target setpoint temperature for a hydronic boiler. The setpoint is based on the System Sensor (S3) in primary/secondary piping configurations or cascade primary piping configurations. For single-boiler primary piping configurations the setpoint temperature will be based on the boiler outlet water sensor.

Review the applicable product I&O manual for adjustment ranges.

6.7. Tank Setpoint (TANK SETP)

This is the setpoint temperature for the storage tank, at Sensor (S3). It is only available to set/change when the PIM identity is "WH". A range of 50 to 160°F (10 to 71°C) is available. For temperatures above this range, use a boiler model configured in Mode 1 for process application.

6.8. Pool Setpoint (POOL SETP)

This is the setpoint temperature for the pool at the S3 sensor. This value is only available to set/change when the PIM identity is "P". As shipped, a range of 50 to 104°F (10 to 40°C) is provided.

The max setting can be extended to 106°F (41°C) by accessing this setting, pressing both the UP and DOWN arrows for 3-seconds, then pressing the UP arrow. This procedure must be repeated each time this screen is accessed.

6.9. Pool Maximum Supply (SUPPLY MAX)

This is the maximum supply temperature to the pool at the S6 sensor. This value is only available to set/change when the PIM identity is "P". The heater will shut down if the temperature exceeds this maximum value. The range of adjustment is 110 to 120°F (44 to 49°C).

6.10. Differential Settings

A heat source must be operated with a differential in order to prevent short-cycling. The heater differential is divided around the heater target temperature.

1. Target Differential (TARGET DIFF)

This value is only available to set/change when the PIM identity is "H" and the PIM DIP switch #1 (Operator Differential) is set to ON (Manual Differential). Target Differential is split equally above and below the target setpoint (SETPoint). For example, in the case of a 180°F (82°C) setpoint with a 10°F (6°C) differential, the control will energize the boiler when the controlled temperature drops to 175°F (80°C) and then will shut the boiler off at 185°F (85°C). The Target Differential defaults to 10°F (56°C) with a range of 2 to 42°F (1 to 24°C).

2. Tank Differential (TANK DIFF)

Tank Differential applies below the setpoint. For example, in the case of a TANK SETP setpoint of 130°F (54°C) with a 6°F (4°C) differential, the control will energize the heater when the tank temperature drops to 124°F (51°C) and then will shut the heater off at 130°F (54°C). The Tank Differential defaults to 5°F (3°C) with a range of 2 to 10°F (1 to 24°C). This value is only available to set/change when the PIM identity is "WH".

3. Pool Differential (POOL DIFF)

Pool Differential applies below the setpoint. For example, in the case of a POOL SETP setpoint of 80°F (27°C) with a 2°F (1°C) differential, the control will energize the heater when the pool temperature drops to 78°F (26°C) and then will shut the heater off at 80°F (27°C). The Pool Differential defaults to 2°F (1°C) with a range of 1°F to 5°F (1 to 4°C). This value is only available to set/change when the PIM identity is "P".

4. Indirect Differential (IND DIFF)

Indirect Differential is the differential for the indirect DHW tank temperature. It applies below the setpoint. For example, in the case of an IND SETP setpoint of 130°F (54°C) with a 6°F (4°C) differential, the control will energize the heater when the tank temperature drops to 124°F (51°C) and then will shut the heater off at 130°F (54°C). The Indirect Differential defaults to 6°F (4°C) with a range of 2°F to 10°F (1 to 24°C). This value is only available to set/change when the PIM identity is "H" and MODE = 2 or 3 and DHW SENS = ON.

6.11. System Pump Purge (SYS PURGE)

The VERSA IC continues to operate the system pump after the system is shut down, either by removing the enable closure or by warm weather shut down (when used). When SYS PURGE is set to OFF, there is no system pump post purge.

The default timing is 20-sec (0:20 min), but can be adjusted from 20-sec to 20-minutes.

6.12. Maximum Target Boiler Temperature (TARGET MAX)

This is the maximum target temperature that the boiler can be set to. This value is only available to set/change when the PIM identity is "H". Refer to the product-specific Installation and Operation Manual for adjustment range.

6.13. Minimum Target Boiler Temperature (TARGET MIN)

This is the minimum target temperature that the boiler can be set to. This value is only available to set/change when the PIM identity is "H". The range of adjustments is from 50 to 180°F (10 to 105°C).

6.14. Indirect Sensor Selection (IND SENSOR) (S6)

This setting determines whether a DHW sensor or an aquastat will control the indirect DHW tank temperature. This value is only available for set/change when the PIM identity is "H" and the MODE = 2 or 3. The setting can be "ON" or "OFF". The default value is "OFF." Contact closure is required for operation across the IND DHW Override terminals when using the IND Sensor option.

⚠ CAUTION: When using the IND Sensor, it is recommended that the operator setpoint dial on the PIM be set for DHW Target temperature to prevent an over-temperature condition from occurring. An aquastat may be installed on the discharge pipe of the indirect DHW tank to act as a secondary limit.

6.15. Target Indirect DHW Temperature (IND SETP)

This is the target indirect DHW water temperature setting when a DHW sensor is selected. This value is only available for set/change when the PIM identity is "H", the MODE = 2 or 3 and the DHW SENSOR = ON. The range of settings is 50°F (10°C) to 180°F (82°C). The default value is 140°F (60°C).

6.16. Target Boiler Temperature for DHW Heat Exchanger (IND SUPPLY)

This is the target boiler temperature for the DHW heat exchanger during indirect DHW operation. This value is only available to set/change when the PIM identity is "H", the MODE = 2 or 3 and the DHW SENSOR = OFF. The range of settings is 70°F to 200°F (21°C to 93°C) not to exceed "Target Max".

The default value is 180°F (82°C). This setting is only available when using an aquastat in the indirect tank in lieu of a 10k Ohm sensor. When using a sensor this setting is defaulted to the IND SETP plus 40°F (5°C), not to exceed Target Max.

6.17. Selection of Indirect Priority (IND PRIORITY)

This selects whether or not indirect DHW priority is active during indirect DHW operation. This value is only available to set/change when the PIM identity is "H" and the MODE = 2. The setting can be "ON" or "OFF". The default value is "OFF". Mode 3 requires priority functionality due to the piping configuration.

6.18. Priority Override Time (PRI OVR)

This selects the length of time for the priority override. This value is only available for set/change when the PIM identity is "H" and DHW PRIORITY = ON. The settings can be "Au" (Auto) or from 10 min to 2.0 hours. The default value is "1:00 hr". This will maintain the priority override until the CFH in this system is satisfied.

6.19. Cold Water Protection (CWP)

Some applications require reliable protection against harmful condensation caused by frequent, extended, cold water exposure. The CWP system utilizes several configurations with proportional 3-way valve, 2-way valve or injection VS pump system to maintain the inlet water temperature to the unit during operation in order to prevent harmful condensation.

The applicable settings for this operation are enabled and shown within the SETUP menu when the VERSA board DIP switch # 3 is enabled.

The following are the settings for the CWP:

- MIX Type (H and WH Only)
- MIX Target
- MIX Lock
- MIX Speed
- MIX Inv
- MIX Trim

6.20. MIX Type

For Hydronic systems, MIX Type has three options, VALVE, PUMP and PLNT.

VALVE and PUMP assume that each individual unit will have the proper wiring and pipe configuration to control its own inlet temperature. See **Figure 14 on page 13**.

Pump selection is available for High-Temp process applications using H models.

PLNT assumes that a 3-way valve will control the inlet temperature among the entire system (cascade). See **Figure 19 on page 16**.

For Domestic Hot Water systems (WH), Mix Type = PUMP or VALVE only. This is used in conjunction with either a variable-speed injection pump (PUMP) or a fixed speed pump and a 2-way motorized valve (VALVE). See **Figure 31 on page 31**.

6.21. MIX Target

This is the control setpoint for inlet temperature, the default setting is 120°F (49°C). Consult the product-specific manual for required minimum inlet temperature for proper operation.

▲ WARNING: A MIX Target setting below the minimum required for the product being used will cause damage from harmful condensation.

6.22. MIX Lock

The equipment will trigger a warning when "MIX Target" is not reached within 7-minutes. MIX Lock defines whether the system will alarm and continue running or will alarm and lockout the unit. MIX Lock "ON" will shut the unit down and provide an alarm if the inlet temperature is not achieved within 7-minutes, requiring manual-reset. MIX Lock "OFF" will only provide an alarm contact closure while allowing the unit to remain operational if the inlet temperature is not achieved within 7-minutes.

6.23. MIX Speed

This setting defines speed of response. The default setting of MED has been found to provide stable operation in most piping configurations. Depending on product selection and mix of sizes (cascade) the setting can be adjusted to fine-tune the CWP operation.

6.24. MIX Inv

This option is related to the use of spring-return actuators with a proportional 2- or 3-way valve for CWP. Valve actuators can be field-configured to provide spring-to-system or spring-to-bypass operation, depending on user preference. This output can be configured for MIX INV "OFF" 0-10 VDC (0% to 100%), or MIX INV "ON" 10-0 VDC (0 % to 100%).

6.25. MIX Trim

This item allows adjustment for various types and sizes of units as well as various actuator motor speeds and types supplied by factory. For systems with very cold start-up temperatures such as snow melt / deicing, the trim may require adjustment to lower values for stable operation. For the majority of the systems with CWP the default value of zero will provide stable operation.

6.26. H Models & MIX Type = PUMP

H models include a cold water protection MIX Type selection for individual injection pump (“PUMP”). MIX Type = PUMP is for those systems that require low lead and/or non-ferrous plumbing systems such as high-temperature potable water (kitchen) or process systems (laundry).

NOTE: For systems requiring temperatures exceeding 160°F (71°C) a boiler-rated model must be used. Use Mode 1 and Manual Differential for this application. Ensure Water hardness does not exceed 15 grains per gallon to prevent scale formation.

For more detailed information about this configuration refer to the product-specific Installation and Operation Manual.

⚠ WARNING: Operating below the minimum inlet required for the product being used will cause damage from harmful condensation.

6.27. Temperature Units of Measure (°F or °C)

This selects the units of measure to show on the display. The choices are degrees Fahrenheit (°F) and degrees Celsius (°C). The default is degrees Fahrenheit (°F).

6.28. Glycol Selection

The glycol mixture design concentration must be determined with due regard to minimum temperature that the system is expected to encounter. The system designer shall thoroughly evaluate the application in order to both guarantee freeze protection, and to use the least concentrated solutions, per peak performance.

Commercial products are equipped with algorithms that will ensure the most optimum operation when using different glycol concentration as a heating media. User is able to select between 4 different glycol concentrations. See **Table K**.

Concentration by Volume	Ethylene Glycol	Propylene Glycol
50%	-37°F (-38°C)	-28°F (-33°C)
40%	-14°F (-26°C)	-13°F (-25°C)
30%	+2°F (-17°C)	+4°F (-16°C)
25%	+15°F (-9°C)	+17°F (-8°C)

Table K. Glycol Concentration

The glycol protection will reduce the maximum firing rate and change the heating profile. See **Figure 39**.

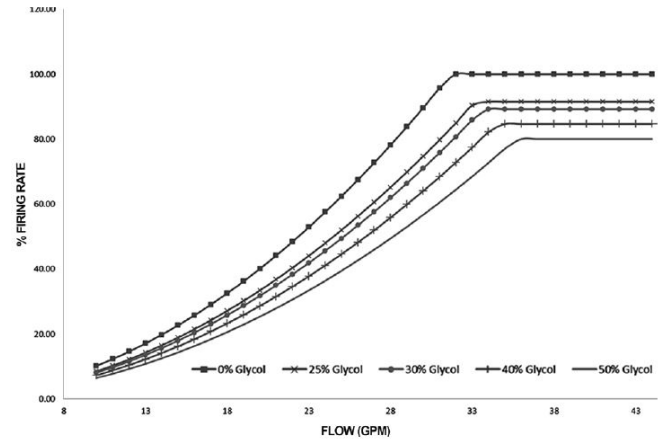

Figure 39. Glycol Operation Chart

This setting can be found in the Adjust menu.

NOTE: Some products will be factory-set to maximum glycol % protection (50%). This value cannot be reset by performing manual default process and should always be manually confirmed during commissioning of the unit.

6.29. Modbus Operating Mode Selection (MODBUS)

This allows the system integrator to select the Modbus operating mode. The choices are “OFF”, monitor (MNTR), temperature control (TEMP) and rate control (RATE). The default setting is “MNTR”.

NOTE: When the unit is defined as follower in a cascade system, selection of this setting is limited to only (Monitor).

6.30. Modbus Component Address (ADDRESS)

This assigns a slave address to components on the Modbus communication network. The range of adjustments is 1 to 247. The default value is 1.

6.31. Vent Protection

Some boilers are equipped with a vent temperature sensor located at the rear of the boiler. Refer to your boiler’s I&O manual.

The vent protection algorithm will anticipate a flue temperature overshoot and adjust the firing rate of the boiler to prevent excessive flue temperatures from occurring.

NOTE: The factory default is set to “PVC”.

During commissioning of the boiler, the vent material must be selected in the Adjust Menu (Submenu of System Settings) to indicate the vent material installed on the boiler. The boiler must be in IDLE for the menu to be selectable.

The settings for the Vent Protection include:

- Vent Material.
 - PVC (149°F/65°C),
 - CPVC (194°F/90°C),
 - PPS (Polypropylene) (230°F/110°C),
 - Stainless Steel (AL29-4C) (no limit switch required)
- Vent Differential: Subtractive value from maximum vent temperature that defines when the control will take action to prevent unit from reaching the maximum vent temperature. Default 10°F (5.6°C) selectable from 1°F (0.6°C) - 20°F (11°C).
- Vent Rate: This value defines the maximum firing rate the boiler will be allowed to operate when Vent Protection is active. If the vent temperature exceeds the allowable limit for the vent material selected, the burner will cycle. This is an automatic reset function, and as soon as the vent temperature drops to an acceptable level, the boiler will return to normal operation.

NOTE: The use of PVC/CPVC will require the user to limit the maximum setpoint of the boiler in the Adjust menu.

Setting the vent material as "stainless steel" effectively disables the vent protection algorithm.

6.32. Modbus Data Type (DATA TYPE)

This assigns the Modbus data type. The options include "RTU" and "ASCII". The default is "RTU".

6.33. Modbus Communication Baud Rate (BAUD RATE)

This assigns the communication speed for the Modbus communication network. The choices include: 2400, 9600, 19K2, 57K6 and 115K. The default value is 19K2.

6.34. Modbus Parity (PARITY)

The choices are "NONE", "EVEN" and "ODD". The default is "EVEN". 1 stop bit is used for "EVEN" or "ODD". 2 stop bits are used for "NONE".

NOTE: For MODBUS memory map details, see Table Z on page 76 through Table AG on page 82.

6.35. Heater Mass (BOIL MASS)

The heater mass setting (1 or 2) applies only to boilers. It allows the installer to adjust the VERSA IC to the thermal mass of the system. See **Table L**. The heater mass setting automatically determines the preliminary PID modulation parameters.

Heater Mass Definitions	
Mass = 1	Fast response
Mass = 2	Standard response

Table L. Mass Parameters

NOTE: Always start with a heater mass setting of 2 (Default).

6.36. Boiler Pump Purge (BOIL PURGE)

The VERSA IC continues to operate the boiler pump after the burner shuts down for the time selected. When BOIL PURGE is set to OFF, there is no boiler pump post purge. The default timing is 3:00 min, but can be adjusted from 20-sec to 10-minutes.

⚠ CAUTION: Continuous pumping through any unit in a Primary/Secondary piping configuration is not supported and may cause a non-warrantable failure.

7. ADDITIONAL OPERATIONAL FEATURES

7.1. Outdoor Reset Operation

When a building is being heated, heat escapes through the walls, doors, and windows to the colder outside air. The colder the outside temperature, the more heat escapes. If you can input heat into the building at the same rate that it is lost out of the building, then the building temperatures will remain constant. The Reset Ratio is an adjustment that lets you achieve this equilibrium between heat input and heat loss.

The VERSA IC can change the System Setpoint based on outdoor temperature (Outdoor Reset), registered at Sensor (S4). The VERSA IC varies the temperature of the circulating heating water in response to changes in the outdoor temperature. The heating water temperature is controlled through the modulation and/or sequencing of the cascade.

The VERSA IC can also control the system circulating pump with an adjustable Warm Weather Shutdown temp (WWSD). See "**Warm Weather Shut Down (WWSD)**" on page 47.

When the outdoor temperature is above the WWSD Cutoff, the pump is turned off and no heating water is circulated through the system. When the outdoor temperature drops below the WWSD Cutoff, the system pump relay is activated and the heating water circulates through the system. The temperature of the heating water is controlled by the Reset Ratio, Water Offset, and changes with the outdoor temperature.

7.2. Reset Ratio/Outdoor Reset

The starting point for most reset systems is a 1:1 ratio of outdoor temp changes to heating water temperature changes. This means that for every degree the outdoor temperature drops, the temperature of the heating water will increase one degree.

With the VERSA IC, both ends of the slope are adjustable. It is factory set at 70°F (21°C) water temperature (Boil START) at 70°F (21°C) outdoor air (OUT START), and 180°F (82°C) water temperature (Boil DESIGN) at 10°F (-12°C) outdoor air (OUT DESIGN). Each building has different heat-loss characteristics. A very well-insulated building will not lose much heat to the outside air, and may need a Reset Ratio of 2.00 (OD):1.00 (SYS) (Outdoor: Water). This means the outdoor temperature would have to drop 2 degrees to increase the water temperature 1 degree. On the other hand, a poorly-insulated building may need a Reset Ratio of 1.00 (OD):2.00 (SYS). This means that for each degree the outdoor temperature drops the water temperature will increase 2 degrees.

The VERSA IC Reset Ratio allows for full customization to match any building's heat loss characteristics.

A heating curve that relies not only on Outdoor temperature but also on the type of radiation will improve heat comfort. The user can fine-tune these adjustments based on the needs of the specific building.

The control uses the following four settings to determine the reset ratio:

1 Reset Ratio Outdoor Starting Temperature (OUT START)

This is the outdoor temperature at which the control starts to calculate a reset when Outdoor Reset is active. This value is only available for set/change when the PIM identity is "H" and the TARGET = RSET. The range of adjustment is 35 to 85°F (2 to 30°C). The default value is 70°F (21°C). See **Figure 39**.

2 Outdoor Design Temperature (OUT DESIGN)

This is the outdoor temperature that is typically the coldest temperature of the year where the building is located. This temperature is used when doing heat loss calculations for the building. This value is only available for set/change when the PIM identity is "H" and the TARGET = RSET. The range of adjustment is 60 to 45°F (16 to 7°C). The default value is 10°F (6°C). See **Figure 39**.

3 Boiler Design temperature (Boil DESIGN)

This is the water temperature required to heat the system when the outdoor air temperature is as cold as the OUT DESIGN temperature. This value is only available for set/change when the PIM identity is "H" and the TARGET = RSET. The range of adjustment is 70 to 200°F (21 to 93°C) (200 = Boiler Design max value, user-selectable). The default value is 180°F (82°C). See **Figure 39**. The Highest TARGET calculable value is determined by Boil Design setting.

4 Boiler Start Temperature (Boil START)

This is the starting boiler target temperature that the system requires when the outdoor air temperature equals the OUT START temperature setting. The Boil START is typically set to the desired building temperature. This value is only available for set/change when the PIM identity is "H" and the TARGET = RSET. The range of adjustment is TARGET MIN to 150°F (66°C). The default value is 70°F (21°C). See **Figure 39**. The lowest target calculation will be truncated based on the target minimum setting.

7.3. Warm Weather Shut Down (WWSD)

When the outdoor air temperature rises above the WWSD setting, the VERSA IC turns on the WWSD segment in the display.

When the Control is in Warm Weather Shut Down, the Control does not operate the heating system to satisfy any heating demand – however, any water heating or indirect heating load will override the WWSD function until such CFH is satisfied.

This value is only available to set/change when the PIM identity is "H" and the TARGET = RSET. The range of adjustments is from 40 to 100°F (5 to 38°C) or OFF. The default value is 70°F (21°C). The lowest target calculation will be truncated based on the Target Min Setting.

NOTE: WWSD has a differential of 2°F (1°C). Ensure the proper installation of the outdoor air sensor to prevent short-cycling.

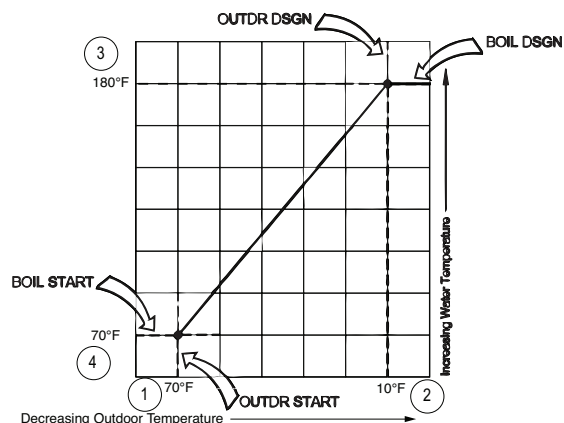

Figure 40. Outdoor Air Reset Curve

7.4. Reset Ratio

The VERSA IC uses the following four settings as shown to calculate the Reset Ratio (RR):

For example, when using the default values, the RR is:

$$\text{RESET RATIO (RR)} = \frac{\text{OUTDOOR START} - \text{OUTDOOR DESIGN}}{\text{BOILER DESIGN} - \text{BOILER START}}$$

$$\text{RR} = (70 - 10) / (180 - 70) = 0.55$$

7.5. Pump and CWP Exercise

This feature (when enabled via DIP switch #4 on the PIM is set to ON) will cycle the pumps and CWP, if enabled, for 10-seconds every 72 hours, even with no heat demand, to help extend the life of the pumps. During this operation, the word “EXERCISE” will display on the VERSA IC Display.

7.6. Freeze Protection

This feature (when enabled via DIP switch #7 on the PIM being set to ON) will cycle the boiler pump on if either the inlet or outlet heater sensors drops below 45°F (7°C). The pump will continue to operate until the temperature rises above 50°F (10°C) at both sensors.

If the temperature continues to drop below 38°F (4°C) at either sensor, the heater will enable a heating cycle to operate at minimum firing rate to raise the water temperature in the boiler to avoid freezing. The heating cycle will terminate when both the Inlet and Outlet temperatures rise above 42°F (6°C).

Should the heater be in a soft-lockout condition, the Freeze Protection operation will override all soft-lockout timers to operate; however, it will NOT override a hard lockout.

Freeze protection is functional with the VERSA IC operator, but will also function in “limp-along” mode should the VERSA IC not be functioning, as long as the PIM DIP switch #7 is ON.

7.7. Heater Rotation

When configured for cascade operation, the Master VERSA can be user-defined to provide lead rotation. Lead rotation, when selected via VERSA DIP #6, is fixed at 48 hours of burner run time as measured between the lead unit and any other cascade member run time. Once there is 48 hours difference in burner run time between the lead unit and another cascade member, the lead will rotate to the unit with the least amount of burner run time once the current CFH is satisfied. The remaining units will be operated sequentially based on their order within the cascade.

Another feature of the rotation function is to force a rotation event to occur after 60 hours of the lead stage operating continuously due to a continuous CFH from the system. In the event that the lead unit is not allowed to cycle off due to a continuous demand, the VERSA IC will force the cascade to achieve “target + differential” by increasing the firing rate of the active unit until the system temperature is satisfied. Once the system temperature is satisfied, the active unit will cycle off. This will in turn allow the rotation event to occur to ensure equalized runtime of the cascade members.

7.8. Target Differential – Auto/Manual

The VERSA IC system is configured as standard with an “Auto Differential” feature (H models only). This function serves as part of how the controller attempts to achieve a minimum ON time to ensure maximum system and boiler operating efficiency. The VERSA IC will automatically adjust the target differential during each cycle as needed to prevent short cycling of the burner, while also trying to maintain the system supply temperature as close to target as is possible. The user can select via DIP switch #1 on the PIM to disable the auto differential function and set a fixed differential. Typically a manual differential is suggested when operating at elevated temperatures near the limit of the appliance. This is done to prevent overshooting the temperature so as not to trip the manual-reset high limit. The manual differential is adjustable from 2 to 20°F (1 to 11°C) and is split equally above and below the target temperature.

7.9. Minimum Run Time

The VERSA IC system attempts to maintain a minimum run time of 210-seconds for each heater. This is accomplished several ways automatically by the control system. One method is by automatically adjusting the differential (Auto DIFF) used around the target temperature, and another is by extending the OFF time of the burner to achieve longer ON times. However, should the temperature exceed one-half the calculated differential above the target temperature, the heater will shut down. Conversely, if the system temperature exceeds the full differential below the target temperature, the heater will fire to achieve the setpoint.

7.10. Outdoor Sensor Fault Operation

If the Outdoor Sensor is open (OPN) or shorted (SHT), the alarm will signify the fault, but the boiler will continue operation and set the TARGET temperature based on an outdoor temperature of 32°F (0°C).

7.11. System Sensor Fault Operation

If the System Sensor is not functioning, the heater will alarm to signify the fault but will still operate to achieve target based on the Outlet Sensor. The boiler pump will be enabled to run continuously during this fault to ensure water flow is moving past the active outlet sensor.

7.12. Field Test

Whenever the heater is IDLE or in lockout, pressing and holding the test/reset button on the PIM (or the reset button on the heater membrane switch – if present) for a period of 5-seconds shall initiate a field test mode. The PIM will light the amber Alarm/Test LED indicator and sequentially turn on the pump outputs for a minimum of 10-seconds each. Pressing and holding the test button (or reset button) for at least 1-second will cancel the field test and the PIM Alarm/Test LED shall be turned off.

7.13. LED: User Test

This test is accessible from the TOOLBOX menu on the VERSA IC Display. "USER TEST" is displayed on the first line of the display and "OFF" is shown on the second line. "USER TEST" remains on the first line of the display throughout this testing mode. Only the second line of the display changes to show the state of operation. When this function is enabled (push the UP button on the membrane switch), the system begins a system-wide test of the heater. See **Table M**. "STRT" appears on the display, then the system pump is enabled (and the display shows "SYS"). After approx. 10-seconds, the DHW pump is enabled (and the system pump disabled) and the display shows "DHW". Approx. 10-seconds later, the boiler pump is enabled along with the system pump (the display shows "PMP1"). After approx. 10 more seconds, the display will show "Boil 1" which initiates a CFH for this User Test. If the heater is enabled to run, the heater will go through a normal trial for ignition and light. If ignition is successful, the display will show "MIN1" and the heater will operate at minimum firing rate. Pushing the UP button on the membrane switch will hold the firing rate at this level as long as desired and the display will flash "HOLD" at 1-second intervals during this period of time.

NOTE: If the heater outlet temperature approaches the PIM Hi-Limit value, the heater will ramp down the firing rate to keep the temperature in a safe operating range.

Pressing the UP button again will step the program to ramp up the firing rate to maximum input and "MAX1" will display. Pressing the UP button again will hold this firing rate for as long as desired and the display will flash "HOLD" at 1-second intervals during this period of time. Any CFH received from the system during this User Test will be ignored until the test is completed.

Displayed	Output Action
SYS	System Pump relay turns on.
DHW	DHW Pump relay turns on.
PMP 1	System and Boiler Pump relays turn on.
CWP 1	CWP Proportional Output.
Boil 1	Ignite Boiler Burner.
Max 1	Ramp Boiler to Max Fire and hold.
Min 1	Hold Boiler at Min Fire.

Table M. User Test Operation

For Cascade configurations, the USER TEST item is only available though the Master unit. To perform a user test at each individual Follower, go to each Boiler menu from the Master user interface, and enable only the boiler to be tested.

When CWP is enabled (VERSA Control Board DIP#3) VALVE becomes available for USER TEST.

7.14. Touchscreen: User Test

Set DIP switch #1 on the VERSA IC to "ON". On Touchscreen, click Menu icon, Tools icon, Systems Tools. Press "Start" to initiate User Test sequence.

- User Test START is displayed.
- Pressing Hold/Skip button advance through the user test.
- The Boil MIN/MAX steps for burner operation are only run for enabled heaters.
- Local Heat/DHW/EMS demands must be present for burner operation.
- On the first press of the Hold/Skip button, the test step is held and "HOLD" is flashed at 1Hz.
- On the second press of the Hold/Skip button, the test step is incremented.
- If heater outlet temperature reaches the PIM Hi-Limit, the heater will be ramped down to keep the temperature in a safe range.
- Press of the Hold/Skip button from Heater Max will End the User Test function.
- CWP MUST be enabled (VERSA DIP #3) VALVE must be functioning during USER TEST.

NOTE: If USER TEST is performed with Cold Water Protection enabled (VERSA DIP 3 = ON), allow valve or VS pump test sequence to complete uninterrupted or a fault condition may occur.

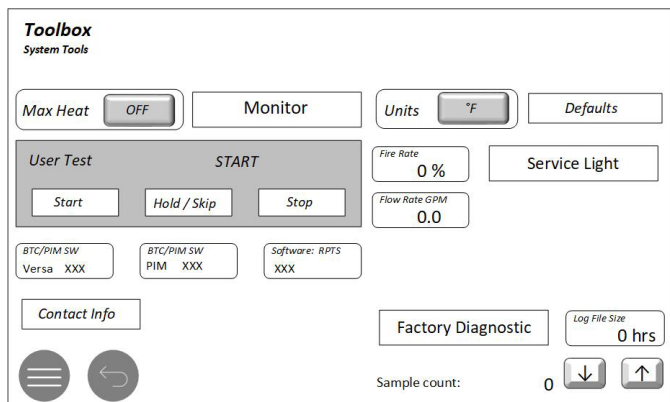

Figure 41. Touchscreen Toolbox Menu

8. SEQUENCE OF OPERATION

1. Upon initial application of 24VAC power, the PIM resets with all outputs in the “OFF” state.
2. The PIM and VERSA Control Board perform a processor and memory self-test to ensure proper operation.
3. The PIM confirms the presence of a valid ID Card which matches the configuration stored in memory at the factory. If a valid ID Card is NOT present, the PIM generates a diagnostic fault and will shut down waiting for this fault to be addressed.
4. The PIM reads the DIP switch settings and configures itself for the desired operation.
5. The PIM scans the Ft_bus communications for the VERSA Control Board and if found, system operation is controlled by the VERSA IC.
6. Non-volatile memory is checked for any active lockout conditions. If any exist, they must be addressed before the PIM will allow a new trial for ignition to start.
7. The PIM continually monitors the flame status to ensure that no flame is present during Standby. If an erroneous flame is detected, the PIM generates a False Flame error fault.
8. The PIM verifies that the vent sensor (some models) is below the vent limit temperature before burner operation. If the vent temperature is exceeded, the PIM performs a Post-purge and proceeds to a hard lockout.
9. A CFH is initiated by the presence of any one or more of the 4 sources below:
 - a. A heat demand (contact closure) on the TH field wiring terminals with closure across enable/disable.
 - b. A voltage greater than 0.5 VDC on the analog 0-10 VDC EMS signal input.
 - c. A heat demand present on the DHW field wiring terminals.
 - d. A heat demand from the VERSA IC based on the DHW sensor temperature.
10. The PIM initiates a Trial-For-Ignition (TFI) counter to the programmed number of trials for ignition (1 or multiple) and proceeds to energize the heater pump or open the motorized isolation valve. Any fault will close the alarm contacts.
11. The VERSA IC will turn on the system, boiler and/or DHW pump or isolation valve as necessary to address the call-for-heat. This is dependent on the Mode of operation selected. The pumps/valves will proceed through their purge period before the control will move into a TFI. For systems with CWP enabled, the MIX output is sent to the MIX MIN % value.

7.15. Commission Test Mode (Hi-Limit Test)

When the PIM DIP switch #8 is turned to the ON position, a Commission Test Mode is activated. The PIM lights the amber Alarm/Test LED. This mode activates certain functions to assist initial commission testing of the system. The configured high limit temperature is overridden to match the setpoint potentiometer position. The high limit can then be adjusted by the potentiometer to assist commission testing and verification. The operating setpoint is automatically set to 20°F (11°C) above the high limit (stand-alone mode), or it can be controlled by the VERSA IC.

7.16. Max Heat Function

This function sets the target temperature to TARGET MAX whenever any demand is present. In addition, the DHW priority is disabled and WWSD is disabled. The Max Heat function will be aborted if 24 hours has elapsed since it was initiated or if the user sets MAX HEAT = OFF in the TOOLBOX menu.

7.17. Max Delta-T Protection

The VERSA IC system is capable of controlling the operation of the heaters so that a maximum value of Delta-T is not exceeded in an attempt to protect the heaters from flashing to steam or damaging the heat exchanger due to scale which can form at high temperatures.

If the Maximum Delta-T value is exceeded, the heater will shutdown (pumps will continue to operate), the alarm light will turn on and the display will show “Delta-T ERR”. Once the Delta-T drops below half the maximum value, as defined by the unit type, the alarm light will turn off and the heater will return to IDLE state until a CFH is present.

This value is set by the PIM and is not adjustable.

- Hi Delta, MVB, XTherm, XFiire, IFire 40 Delta-T (°F)
- WH, P 2003A-2004A ONLY 35 Delta-T (°F)
- all other WH and P units 30 Delta-T (°F)
- XVers allows up to 80°F (27°C)
- XPakFT allows up to 60°F (16°C)

12. If present, the VERSA IC will verify flow at the flow sensor to ensure flow is equal to or greater than minimum flow required for ignition.
13. The VERSA Control Board and PIM check the safety circuit and will not go into a Trial for Ignition if any of the safety devices is in an error/fault condition, which will also close the alarm contacts.
14. The fan/damper contacts are energized to trigger an external device which must prove operational before the unit is allowed to fire. Once the external interlock contacts close, the sequence proceeds.
15. If no fault condition is found, the air pressure switch (if present) is verified to be in the open position before the blower is energized.
16. The blower(s) are energized and set to pre-purge speed (if modulating).
17. The air pressure switch is verified to close within 60-seconds to prove air flow.
18. Once the air pressure switch closes (or the blower speed is acknowledged as operating at the pre-purge speed by the tachometer output), the blower proceeds to pre-purge for the specified duration.
19. The voltage level of the 24VAC supply input is confirmed to be above 18.0VAC – if not, a Low Voltage fault will be recorded and the heater will go into a soft lockout condition until the voltage rises above 18.0VAC consistently.
20. If all checks have passed, the system proceeds to ignition.
21. The PIM initializes the ignition counter to the configured number of trials (typically 1 or 3).
22. The Hi Limit sensor is confirmed to read below the Hi Limit setpoint.
23. The blower light-off RPM speed (modulating blowers only) is verified.
24. The gas valve relay contacts are verified open – if closed, a fault code will be issued and the heater will post-purge and go into a hard lockout condition.
25. On heaters equipped with a Hot Surface Igniter:
 - a. The control turns on the HSI and the HSI proving current is verified to be above the configured value.
 - b. The configured heat-up delay takes place to allow the HSI element to reach ignition temperature.
 - c. The gas valve output (and external safety valve, if present) is energized for the TFI time to light the burner.
 - d. The HSI (and external safety valve, if present) is/ are de-energized during the last second of the TFI period to sense for the burner flame.
 - e. The flame sense is checked for successful ignition. If a valid flame is detected, the main gas valve, operating pumps and blower relay remain energized and the PIM proceeds to the Heating mode. For systems with CWP enabled, the MIX output is released to its control point based on distance from Inlet temperature target.
26. On heaters equipped with a DSI (Direct Spark Igniter):
 - a. The DSI igniter is energized.
 - b. The gas valve output is energized for the TFI time to light the burner.
 - c. The flame sense is checked for successful ignition. If a valid flame is detected, the sparking is terminated, the main gas valve, operating pumps and blower relay remain energized and the PIM proceeds to the Heating mode. For systems with CWP enabled, the MIX output is released to its control point based on distance from Inlet temperature target.
27. If flame is not detected during the TFI period, the gas valve output is disabled immediately and the blower goes to a post-purge.
 - a. On single TFI models, the PIM enters ignition lockout and the LED on the PIM indicates the fault code for ignition lockout. The VERSA IC Display should also state Ignition Lockout.
 - b. On multi TFI models, the control goes through an interpurge delay before additional ignition attempts are started. If no flame is detected after the final TFI, the PIM enters ignition lockout and the LED on the PIM indicates the fault code for ignition lockout. The VERSA IC Display should also state Ignition Lockout.

NOTE: On CSD-1 controls, recovery from ignition lockout requires a manual-reset by either pushing the RESET button on the display (if the heater is so equipped) or pushing the reset button on the PIM (located next to the LEDs) on lockout controls. Recovery from ignition lockout on auto-reset controls can be accomplished by recycling the call-for-heat, removing 24VAC (turning the power off to the heater) from the PIM for a minimum of 5-seconds, or the control will automatically reset and start a new heating cycle if the CFH is still active and the configured reset time has elapsed.

28. During a heating cycle the flame status, air pressure switch, LWCO, water pressure switch and other safety switches are continually monitored for proper state. On any alarm state, the alarm contacts are closed.
29. The System temperature is monitored against the target temperature to determine the proper firing rate or staging level. Cascade Configurations utilize either sequential or parallel staging (Product-specific) for Follower units as required to achieve and maintain target temperature.

30. The PIM remains in heating mode until the staging reaches 0% or the firing rate drops below the configured minimum value for the heater.
31. When the CFH is satisfied, the gas valve(s) are immediately disabled, a blower post-purge is completed and the controls proceed to IDLE mode.
32. The pumps/valves complete a purge period as set in the ADJUST menu.
 - a. Should a loss of flame occur on Direct Spark Ignition models during a heating cycle, the control will energize the high voltage spark igniter within 0.8-seconds for the configured TFI period in an effort to relight the burner (multi-try models allow 3 tries for ignition with inter-purges). If the burner relights, normal operation is resumed. If the burner does not relight, the gas valve is de-energized immediately and the control will go into ignition lockout.
 - b. Should a loss of flame occur on Hot Surface Ignition models during a heating cycle, the gas valve is de-energized within 0.8-seconds and the blower goes through an inter-purge. After the flame recycle delay, the control attempts to relight the burner (multi-try models allow 3 tries for ignition with inter-purges). If the burner relights, normal operation is resumed. If the burner does not relight, the gas valve is de-energized immediately and the control will go into ignition lockout.

NOTE: Cascade systems will operate automatically to bring on the next available Cascade member in the event of a soft or hard lockout condition in an attempt to satisfy an active call-for-heat.

9. WIRING CONNECTIONS - PIM

The following information relates to the wiring connections on the PIM, VERSA IC system and VERSA IC display boards. Refer to each product-specific Installation and Operation Manual for specific connections. See **Figures 42 through 44**.

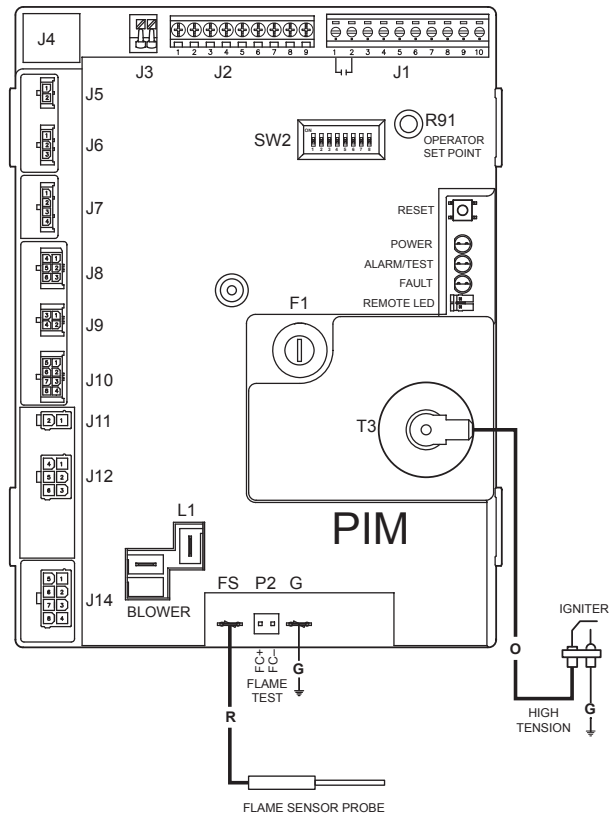

Figure 42. PIM Connections – DSI Control

9.1. PIM Low-Voltage Connections (30VAC Max)

Connector	Pin #	Function	Type & Rating
J1	1	Alarm Contacts	0-30VAC, 2.0A Max – Dry contact
J1	2	Alarm Contacts	0-30VAC, 2.0A Max – Dry contact
J1	3	N/A	18-30VAC, 2.0A Max (Jumpered to pin 4)
J1	4	24VAC Out (R)	18-30VAC, 2.0A Max
J1	5	Remote Reset	0-30VAC, 2.0A Max
J1	6	N/A	18-30VAC, 2.0A Max (Jumpered to pin 7)
J1	7	24VAC Out (R)	18-30VAC, 2.0A Max
J1	8	DHW Call (DHW)	0-30VAC, 2.0A Max
J1	9	Heat Call (TH)	0-30VAC, 2.0A Max
J1	10	24VAC Out (R)	18-30VAC, 2.0A Max
J2	1	DHW Sensor	10K Thermistor – J Curve

Connector	Pin #	Function	Type & Rating
J2	2	DHW Sensor Common	10K Thermistor – J Curve
J2	3	System Supply Sensor	10K Thermistor – J Curve
J2	4	System Sensor Common	10K Thermistor – J Curve
J2	5	Outdoor Sensor	10K Thermistor – J Curve
J2	6	Outdoor Sensor Common	10K Thermistor – J Curve
J2	7	tN4 Communications	Communications Network Signal
J2	8	0-10VDC Analog EMS Input	0-10VDC or 4-20mA 22AWG Twisted Pair
J2	9	Common	Ground
J3	1	Ft_bus B	22AWG Twisted Pair
J3	2	Ft_bus A	22AWG Twisted Pair
J4	1	PIM to VERSA IC	RJ45

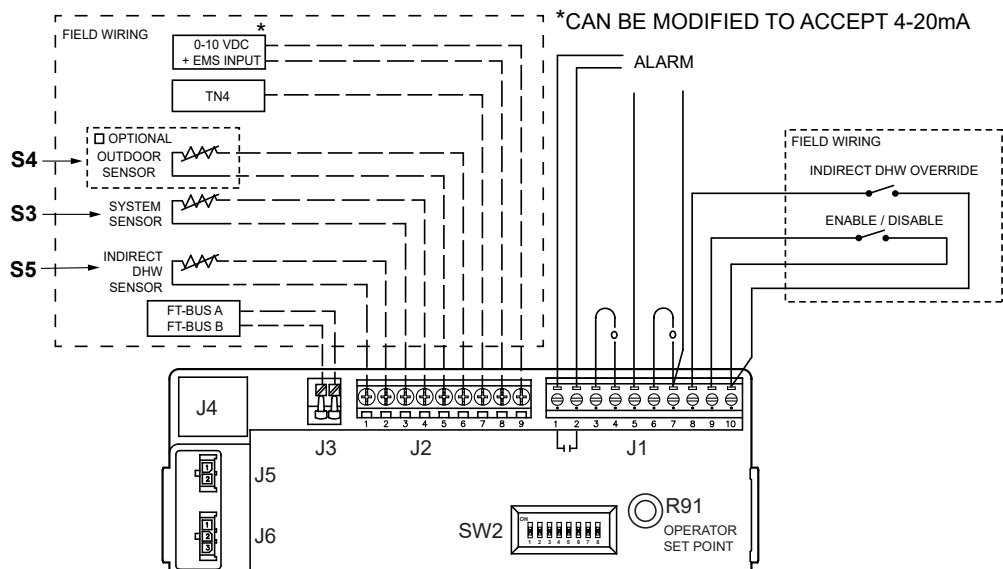

Figure 43. VERSA PIM Control Connections (XPakFT only)

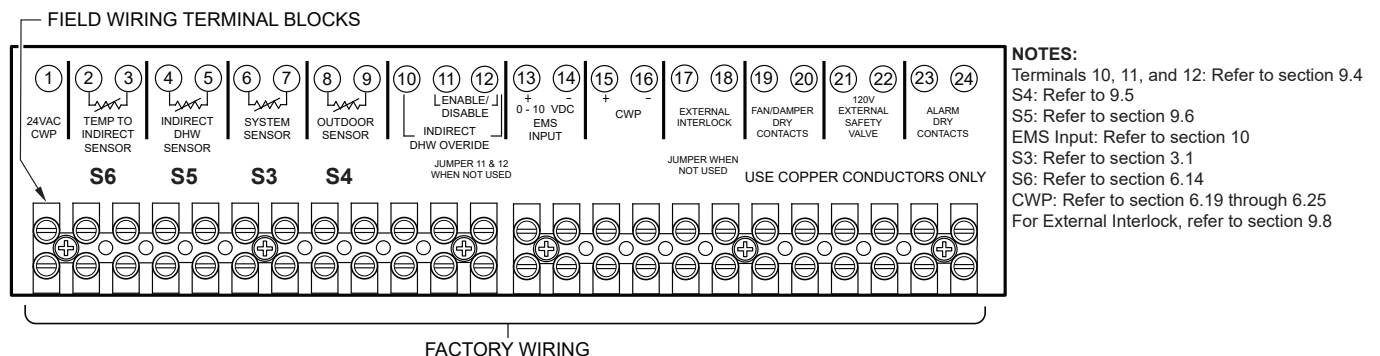

Figure 44. Field Wiring Terminal Block (Hi Delta / MVB / XTherm / XFiire / IFire / XVers / XVersL / XVers with KOR only)

9.2. PIM Factory Low-Voltage Wiring Connections

Connector	Pin #	Function	Type & Rating
J5	1	Ft_bus B (PIM to PIM)	20-30AWG, 2.0A
J5	2	Ft_bus A (PIM to PIM)	20-30AWG, 2.0A
J6	1	ID Card	20-30AWG, 2.0A
J6	2	ID Card	20-30AWG, 2.0A
J6	3	ID Card	20-30AWG, 2.0A
J7	1	Hi-Limit Sensor	10K Thermistor – J Curve
J7	2	Hi-Limit Sensor Common	10K Thermistor – J Curve
J7	3	Outlet Sensor Common	10K Thermistor – J Curve
J7	4	Outlet Sensor	10K Thermistor – J Curve
J8	1	NOT USED	
J8	2	Air Pressure Switch (model specific)	20-30AWG, 2.0A
J8	3	NOT USED	
J8	4	Air Pressure Switch (Model Specific) Return	20-30AWG, 2.0A
J8	5	Safety loop	20-30AWG, 2.0A
J8	6	Safety loop	20-30AWG, 2.0A
J9	1	Inlet Sensor	10K Thermistor – J Curve
J9	2	Vent sensor	10K Thermistor – J Curve
J9	3	Inlet Sensor Common	10K Thermistor – J Curve
J9	4	Vent sensor	10K Thermistor – J Curve
J10	1	4-20mA VS Pump Output	
J10	2	PWM Out (Modulation %)	20-30AWG, 2.0A
J10	3	Flow Sensor	
J10	4	Tachometer Input	20-30AWG, 2.0A
J10	5	Fan Power (18VDC)	20-30AWG, 2.0A
J10	6	Fan Ground	20-30AWG, 2.0A
J10	7	Flow Sensor	
J10	8	Flow Sensor	
J11	1	24VAC Power	30VAC, 8A

Connector	Pin #	Function	Type & Rating
J11	2	24VAC Common	30VAC, 8A
J12	1	Gas Valve Common (Isolated Relay)	120/240VAC, 8A
J12	2	2nd Stage Gas Valve	120/240VAC, 5A
J12	3	Gas Valve Return	120/240VAC, 5A
J12	4	2nd Stage Gas Valve Return	120/240VAC, 5A
J12	5	Gas Valve (MV/PV)	120/240VAC, 8A
J12	6	Valve Power (Isolated Contact)	120/240VAC, 8A
J13	1	Blower Output (L1)	120/240VAC, 5A
J13	2	Blower Output (L2)	120/240VAC, 5A
J13	3	Blower Ground	120/240VAC, 8A
J13	4	L1 Supply Input	120/240VAC, 8A
K5 Relay		F1 & F2 Terminals	120/240VAC, 15A
J14	1	DHW Pump	120/240VAC, 5A
J14	2	Boiler Pump	120/240VAC, 5A
J14	3	L1s – System Pump Supply	120/240VAC, 8A
J14	4	System Pump	120/240VAC, 5A
J14	5	L1 Supply Power	120/240VAC, 8A
J14	6	NOT USED	
J14	7	L2 (Neutral)	120/240VAC, 8A
J14	8	Pumps Ground	120/240VAC, 8A
HV		Spark Output (T3 Coil)	25kV
GND		Burner Ground	
S1		Hot Surface Igniter	5.0A Max
S2/FS		Hot Surface Igniter	5.0A Max
FS		Flame Sense Rod	
P2	FC+	Flame Current Measurement	
P2	FC-	Flame Current Measurement	

Table N. VERSA PIM Control Connections

9.3. Wiring Connections – VERSA IC System

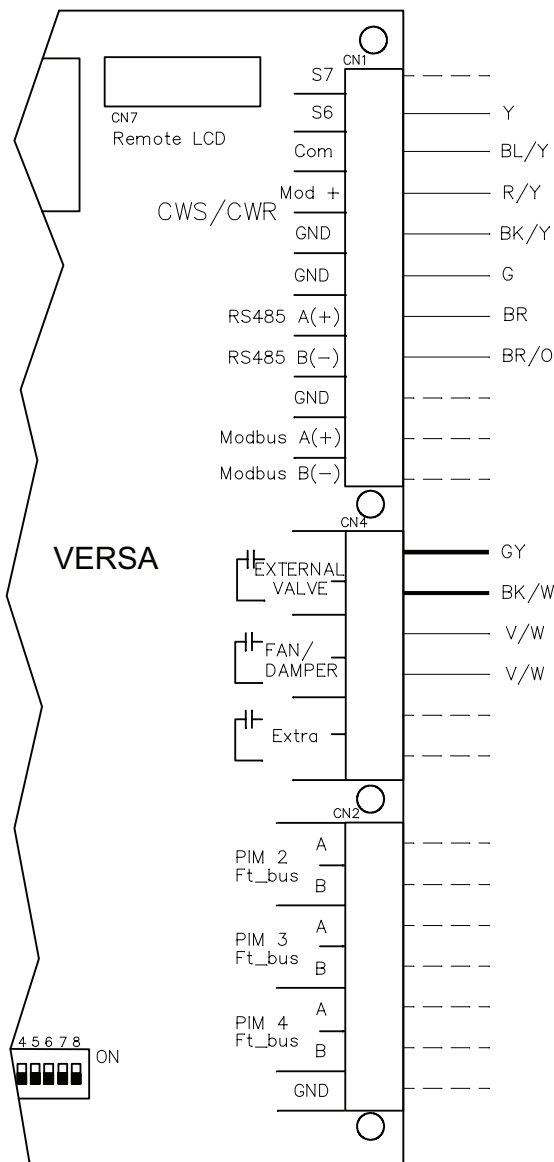

Connector	Pin #	Function	Type & Rating
CN1	1	N/A	(S7)
CN1	2	Aux 1	S6 –IND Sensor
CN1	3	Common	Aux 1 & 2 Common
CN1	4	Mod +	CWS/CWR
CN1	5	Mod -	
CN1	6	RS485 Ground	TOUCHSCREEN
CN1	7	RS485-A	
CN1	8	RS485-B	
CN1	9	ModBus Ground	ModBus Communication link
CN1	10	ModBus-A	
CN1	11	ModBus-B	

Connector	Pin #	Function	Type & Rating
CN4	1	External Valve	Dry contact closure with call for burner
CN4	2	External Valve	
CN4	3	Fan/Damper	Dry contact closure with call for burner
CN4	4	Fan/Damper	
CN4	5	Extra – STATUS (burner)	Dry contact closure with burner flame
CN4	6		

Connector	Pin #	Function	Type & Rating
CN2	1	PIM 2 Ft_bus A	Cascade Connections from Master VERSA IC to Follower PIMs on FT_bus
CN2	2	PIM 2 Ft_bus B	
CN2	3	PIM 3 Ft_bus A	
CN2	4	PIM 3 Ft_bus B	
CN2	5	PIM 4 Ft_bus A	
CN2	6	PIM 4 Ft_bus B	
CN2	7	Shield Ground	

Table O. VERSA IC Connections

9.4. Wiring the Thermostat

Connect the Enable/Disable terminals to the PIM or to the low-voltage field wiring terminals (model dependent). See **Figure 43 on page 53**. Alternately, any dry contact closure (including a remote thermostat) across these terminals will enable the unit to run. Caution should be used to ensure neither of the terminals becomes connected to ground.

9.5. Wiring the Outdoor Sensor (S4)

1. There is no connection required if an outdoor sensor is not used in this installation.
2. If using an Outdoor Sensor (P/N 011934), connect the sensor wires to the terminals marked OUTDOOR SENSOR (PIM J2 connector terminals 5 and 6).

Caution should be used to ensure neither of these terminals becomes connected to ground. See **Figure 43 on page 53**.

3. Use minimum 18 AWG stranded wire for runs of up to 150 feet (46 m).
4. Mount the outdoor sensor on an exterior surface of the building, preferably on the north side of the building in an area that will not be affected by direct sunlight and that will be exposed to varying weather conditions.

9.6. Wiring the Indirect Sensor (S5)

1. There is no indirect sensor connection required if an indirect water heater is not used in the installation. Use 18 AWG stranded wire for runs of up to 150 feet.

- When the Indirect DHW CFH is active, the PIM communicates this to the VERSA Control Board. The VERSA Control Board calculates the optimal operation and sends the firing rate and pump output requests to the PIM so it can activate the Indirect DHW pump and Boiler pump if needed. If an optional Indirect DHW sensor is connected, the PIM will pass this signal to the VERSA Control Board. This allows the VERSA IC to optimize the Indirect DHW demand to maintain the Indirect DHW setpoint. The Indirect DHW thermostat must be closed for proper operation when using the Indirect DHW sensor. It is recommended that a tankstat be used as a limiting device in conjunction with a tank sensor and wired to the Indirect DHW connections at the PIM, or install a jumper across the Indirect DHW override terminals and set PIM operator dial to be equal to DHW Target temperature to prevent an over-temperature condition from occurring. If a VERSA Control Board is not present, the PIM shall activate the Indirect DHW pump whenever the Indirect DHW call is active. The Boiler pump may also be activated based on the Indirect DHW piping configuration setting.
- Connect the indirect tank sensor to the terminals marked INDIRECT DHW SENSOR (see wiring diagram). Caution should be used to ensure neither of these terminals is connected to ground.
- In a pool heating application the pool system sensor must be attached to S6 and Com on CN1 Pins 2 and 3 of the VERSA Control Board. Use 18 AWG stranded wire for runs up to 150 feet (46 m).

9.7. Parallel Pump Wiring Description

In the event of losing the Master unit, Follower units are made capable of operating the System and IND DHW pumps (as required) in “limp-along” mode. See **“LIMP-ALONG” OPERATION OF PIM** on page 66. The System pump outputs from each cascade member must be connected in parallel to activate the system pump during “limp-along” operation.

⚠ WARNING: Failure to properly install and/or wire the System pump and IND DHW pump may result in a system failure during limp-along mode as well as damage to the equipment.

This configuration will allow the system to continue to operate during Master unit failure or loss of the Master unit VERSA Control Board. The IND DHW pump (if applicable) must be also connected in parallel from each individual cascade member output to ensure functionality during “limp-along”.

Figure 45 and Figure 46 illustrate the proper parallel connections method to be used for the System Pump. The same concept must be applied to the IND DHW pump, when applicable.

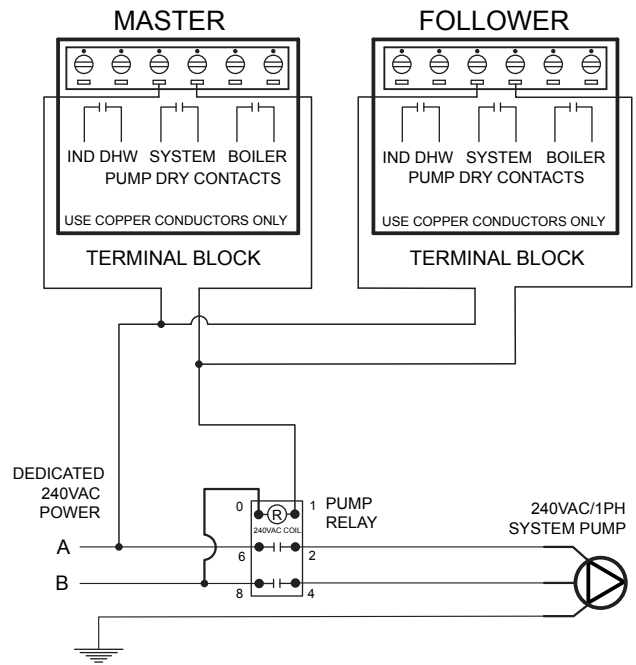

Figure 45. Parallel Pump Wiring Diagram for MVB/XTherm 2503-4505/XVers/XVers L/XVers with KOR XFiire/IFire using 240 VAC Pump Relay

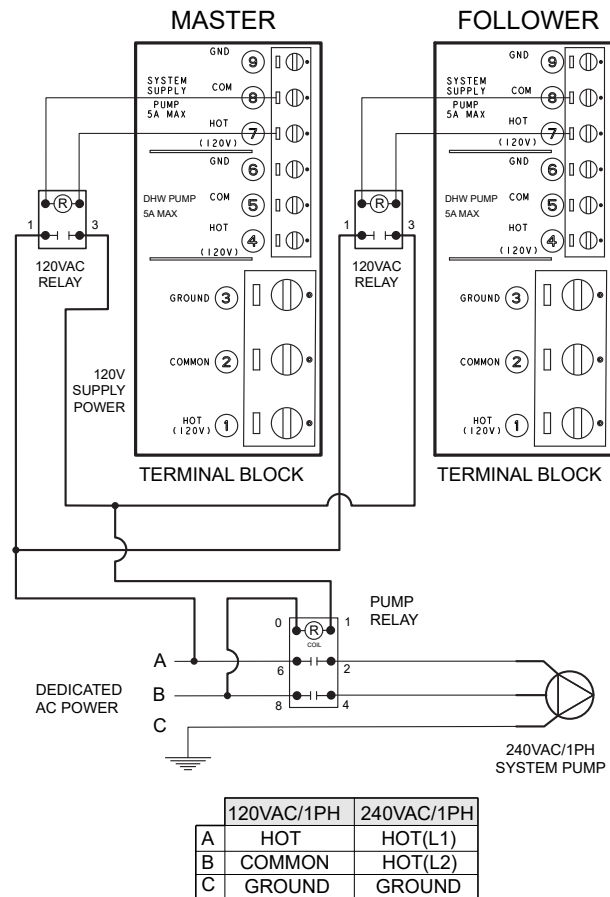

Figure 46. Parallel Pump Wiring Diagram for Hi Delta/XPak FT/MVB/XTherm Models 503A-2005A using 120 VAC Pilot Relay with 240 VAC Pump Relay

9.8. External Interlock

Refer to your unit's wire diagram for reference (refer to the PIM, J8-5 and J8-6 connections). The external interlock is part of a safety "Daisy Chain". All the safeties are wired in series. The safety is powered 24VAC and if any part of the safety chain is open, the CFH will be terminated and the unit will shutdown. A message will display on the touchscreen "E45: Input Safety Chain Error, verify wiring at J8-5/6".

The external interlock is factory-wired with a jumper. The jumper can be removed and a normally open device (or a series of normally open devices) can be connected. See examples in **Figure 47**.

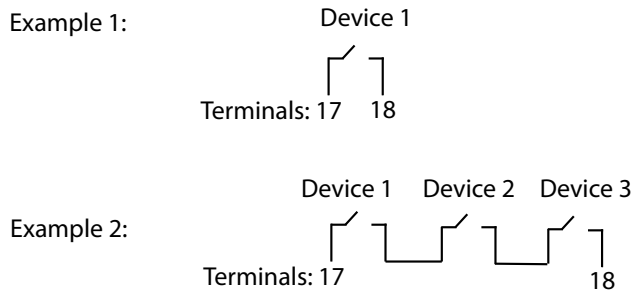

Figure 47. External Interlock Terminal Examples

10. ENERGY MANAGEMENT SYSTEM SETUP

Temperature or Rate Control using an external 0–10VDC or 4-20mA

10.1. Control Signal

1. A signal from an energy management system can be used to control either the setpoint temperature or the firing rate of the heater.
2. To enable this remote control function, set DIP switch #5 on the PIM to the UP position. DIP switch #5 toggles between an EMS ON (UP) signal or a demand signal from the VERSA Control Board OFF (DOWN). Using DIP switch #2 on the PIM, select between Direct Drive (UP) for firing rate or Target Temperature (DOWN) for setpoint.
3. For direct drive (Firing rate) place PIM DIP Switch #2 up for Target temperature (Setpoints) operation place PIM DIP Switch #2 down.
4. For use of a 4-20mA signal, DIP switch #6 must be in the ON (UP) position and a 500 OHM 1/2 watt resistor wired in parallel across the input wires.
5. Connect an Energy Management system or other auxiliary control signal to the terminals marked 0-10V (+/-) on the PIM. See **Figure 43 on page 53**. Caution should be used to ensure that the +0-10V connection does not create a short to ground. See **Figure 53 on page 60**. See **Table P on page 64**.

10.1.1. Temperature Control (Boilers Only)

Remote target temperature can be used in both single-boiler applications as well as multi-boiler cascade to provide target temperature. When configured to allow an energy management system to provide a target temperature input to the VERSA IC, the control requires both a contact closure across the enable/disable connection and a DC voltage input to allow the boiler to fire.

The minimum voltage required to operate the burner is 1.0 VDC (5.6mA) and equates to a target temperature equal to 50°F (10°C) or Target Min setting in the adjust menu. 10 VDC (20mA) equates to the max allowable setpoint for the unit based on the PIM value.

- * 160°F (71°C) XFiire WH, IFire IVGWSF1
- * 180°F (82°C) XVers, XVersL, XVers with KOR
- * 192°F (89°C) XFiire H, IFire IBGWSF1, XPakFT
- * 220°F (104°C) Hi Delta H, MVB H, XTherm H

The TARGET MIN setting in the ADJUST menu of the VERSA IC will serve to truncate the lower temperature range of the EMS signal while the TARGET MAX setting will serve to truncate the upper range of the EMS signal. See **Table P on page 65**.

Example: A specific product has a setpoint range based on the ID card of 50°F (10°C) to 220°F (104°C), therefore, 1 VDC = 50°F (10°C) and 10 VDC = 220°F (104°C). If the Target MIN setting is increased to 140°F (60°C) and the TARGET MAX is reduced to 180°F (82°C) the boiler will respond to a EMS signal as follows. With a contact closure at the ENABLE terminals and a 1 VDC input signal to the boiler, a CFH will be generated to maintain the system at 140°F (60°C) system temperature, for 10 VDC a CFH will maintain 180°F (82°C).

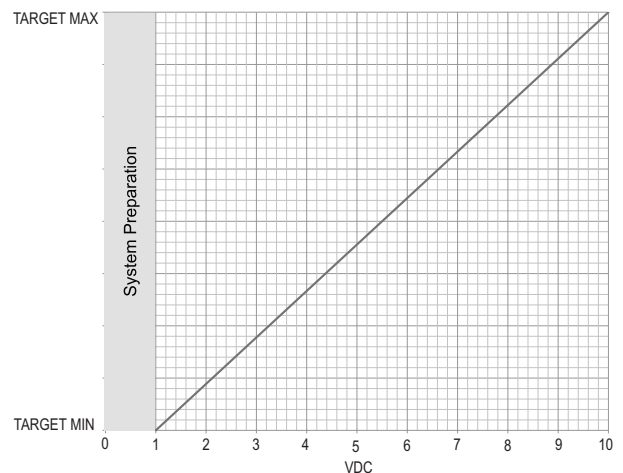

Figure 48. VERSA 0-10 VDC Chart

The VERSA IC will determine the firing rate required to achieve the designated target temperature provided from the EMS.

10.1.2. Rate Control

Firing-rate control will not work with a multi-boiler cascade arrangement. Multi-boiler systems require each boiler to be driven individually when wanting to provide firing rate control from an EMS or multi-boiler sequencer such as factory TempTracker MOD+ Hybrid.

When configured to allow an energy management system to provide a burner firing rate input to the VERSA IC, the control requires both a contact closure at the enable/disable connection as well as a DC voltage input to allow the boiler to fire.

The minimum voltage required to fire the burner is 1.0 VDC (5.6mA). A voltage of 10 VDC (20mA) equates to a call for full fire. To turn off the burner the EMS will need to open the contact across the enable/disable. Reducing the voltage input signal below 0.8 VDC (5.3mA) will also shut-off the active burner call.

NOTE: For staging of Hi Delta units, see Installation Manuals P/N: 241663 & 241664. These manuals can be found in the document library at www.raypak.com.

When operating in response to a firing rate input from an EMS the VERSA IC does not provide temperature control of the system, however will still provide Max Delta-T functionality as well as Manual High Limit operation.

The EMS system is now fully responsible for supply water temperature control as well as managing minimum cycle times to prevent short cycling of the equipment.

11. CASCADE SET-UP AND OPERATION

The VERSA IC system has the capability of controlling operation up to 8 units without the addition of an external sequencing controller.

The first 4 units use the FT bus configuration. See **Figure 56**. The additional 4 units can be expanded via the TN Bus configuration. See **Figure 57**.

In order to establish a cascade system, one unit needs to have the VERSA IC Control Board DIP switch #2 set to the ON position to be recognized as the Master heater in the system. On all other units, turn OFF VERSA DIP switch #2 so the system recognizes them as followers.

For FT bus communication wiring see **Figure 56**. For TN bus units communication see **Figure 57**. Note TN_bus unit communication only require one wire and ground in common.

In addition, for FT_bus units, communication wires need to go from the J3 connections on each follower PIM (minimum 22 AWG twisted pair wire) to the CN2 terminals on the VERSA board on the Master unit. For TN_bus units only one pair of communication wires can run from Master heater PIM to the followers, the rest can be daisy chained from follower to follower. See **Figure 59** and **Figure 62**.

Once the field wiring is installed as per the instructions, remember to enable each of the Follower units within the SETUP menu on the Master.

For TN bus units it is also required to assign a unique address for each unit in the bus. On Menu, ensure FT_bus units have "Cascade" feature set to "OFF". TN4 bus units must have "Cascade" set to any number (non-repeated within same configuration) between 5-8.

Once enabled within the VERSA IC system, the cascade is enabled and heat demand can be controlled from master boiler to begin using the followers to answer any heat request from the system.

If any member of the cascade must be disabled, it must be performed through its local Boiler menu screen.

Steps are the following:

1. On the touchscreen, go to the Boiler menu (flame icon) and select "Boiler 1" see **Figure 49**.

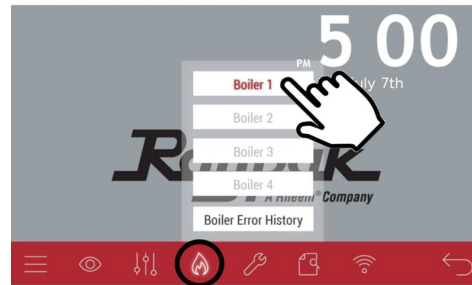

Figure 49. Boiler Flame Icon

2. On the Boiler view, tap on the ">" sign on left side of the screen see **Figure 50**.

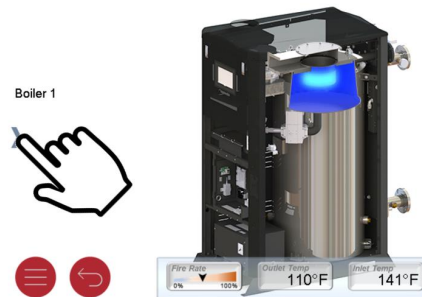

Figure 50. Boiler View Selection ">"

3. A new page will appear, a button on the top left of the screen can be toggled to Enable/Disable the boiler see **Figure 51**.

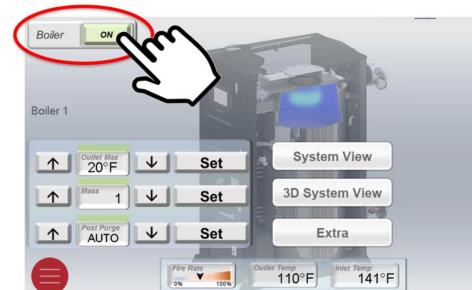

Figure 51. Enable/Disable Boiler

11.1. Cascade Features

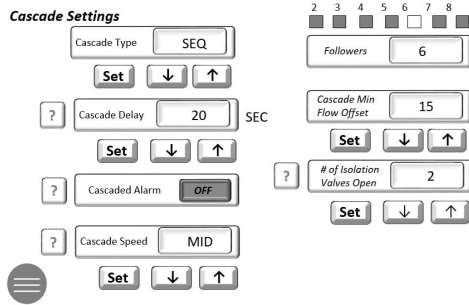

Figure 52. Cascade Master Setting Interface

- a. **Cascade Alarm** - Cascade Alarm sharing setting, by default all units in cascade will share an alarm condition, every time a follower or followers are alarmed. This condition will be shared across all cascade units and the alarm dry contact of each boiler will activate the alarm. This setting can be turned off allowing only those boilers with alarm condition to close their dry contact.
- b. **Cascade Delay** - User selectable off or up to a 600-second delay. The cascade delay is a predefined time period to hold off the next follower in line from firing, regardless of the supply temperature and target.

Once user selected delay has elapsed, the unit will then fire the next unit in cascade.

- c. **Cascade Min Flow** - applicable for primary only piping, overrides MIN flow condition for next unit in cascade to allow next unit to be called to fire sooner or later.
- d. **Isolating Valves** - applicable for primary only piping, shows number of isolating valves open in a cascade configuration.
- e. **Cascade Type** - User selectable configuration for either Sequential (Staging) or Parallel Modulation.
- f. **Cascade ID** - User selectable ID for follower boilers. Only applicable for TN_bus followers.
- g. **Cascade Speed** - Adjusts the response type of cascade system. Available values are SLOW, MID and FAST. Default value is MID. See Figure 53 for reference.

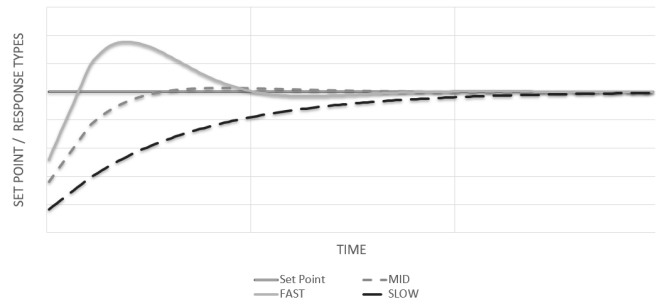

Figure 53. Cascade Speed



Figure 54. Cascade Follower Interface

11.2. Cascade Staging Selection

11.2.1. Cascade Units Local Data

To access data from the first four followers using the FT_bus (see Figure 55), can be through the Master unit using BMS Modbus port. See Tables AB, AC, AD and AE for memory map definitions for Boilers 1 to 4. Master unit also handles System data, see Tables AA, AF and AG for memory map definitions. Data can be accessed through a ProtoNode unit (refer to manual 241515), see Figure 56.

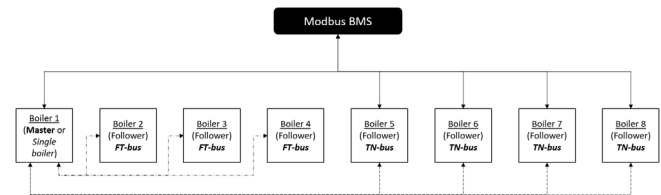

Figure 55. Modbus BMS Cascade Connection

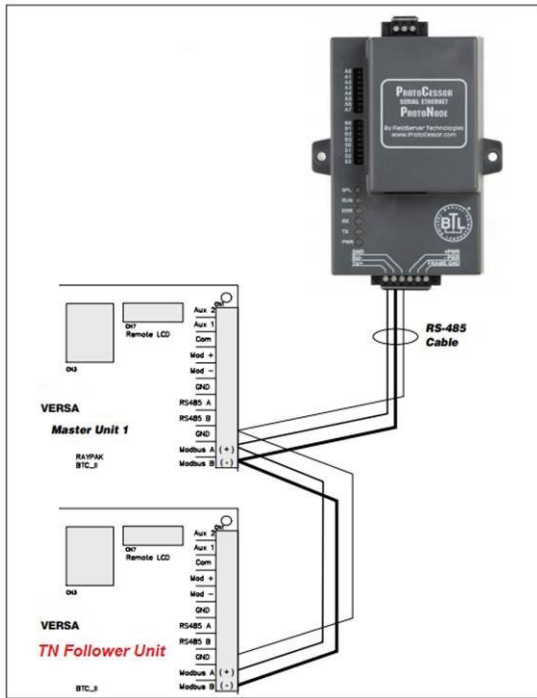

Figure 56. TN Followers Connection Through ProtoNode

For TN bus followers, data is accessible through BMS Modbus port directly to each unit. See Table AB for memory map definitions for every unit.

11.2.2. Sequential Modulation/Staging

Multiple units are handled using a first-on, last-off protocol. The first unit will modulate to support the load.

If it fires at 100% without satisfying the demand, the next unit will be activated and will modulate to support the load; the first unit remains operating at 100%.

If the second unit reaches 100% without satisfying the demand, both units 1 and 2 will remain at 100% while the third unit fires and modulates, etc. As the system temperature approaches setpoint and the load is reduced to the point where a unit can be shut down, the last unit to fire becomes the first to be shut-off.

11.2.3. Parallel Modulation

VERSA equipped products under Modulating Boiler operation support Parallel modulation.

Principle of operation allows first unit to ignite and drive itself to MIN firing rate before calling for next unit in line. If demand is not satisfied by the time the entire cascade system has achieved min firing rate, then all units will modulate together. As the system temperature approaches setpoint and the load is reduced to the point where a unit can be shut down the last unit to fire becomes the first to shut-off.

11.3. Wiring the Cascade System Communication Bus

Designate the primary boiler as the Master boiler/boiler 1 by leaving DIP switch #2 on the VERSA Control Board in the ON position. All other connected units must have their VERSA Control Board DIP switch #2 OFF to designate them as Followers. Follower VERSA Control Boards are ignored by their corresponding PIM Modules.

Use a minimum of 22AWG Stranded Copper wire to connect the Master VERSA board to the PIM on the Followers. Up to 7 Followers can be connected to the master VERSA IC. For systems requiring more than 8 connected boilers, an external sequencer such as the factory TempTracker MOD+ Hybrid can be used.

Use the shortest length cable possible to reach between the boilers. Do not run unprotected cables across the floor or where they will become wet or damaged. Do not run communication cables in parallel with, or close to or against, high voltage (120VAC or greater) wiring.

Factory recommends that the total maximum length of each set of communication bus cables do not exceed 200 feet (61 m).

Connect the Cascade Ft_bus wires to the PIM by pressing down on the slots with a small screwdriver and then inserting the wires into the holes. See **Figure 57**.

Connect the Cascade TN_bus wire to PIM terminal J2-7. It is required for this connection that all PIM's are reference to same communication ground terminal. Connect all grounds in common as shown in **Figure 58**.

NOTE: Do not use shielded cable.

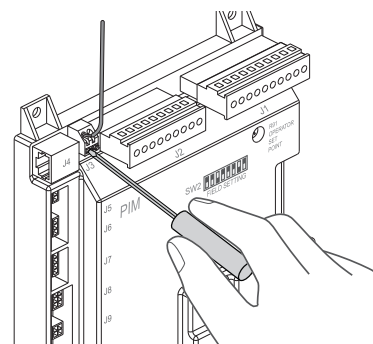

Figure 57. Ft_Bus Wire Connection

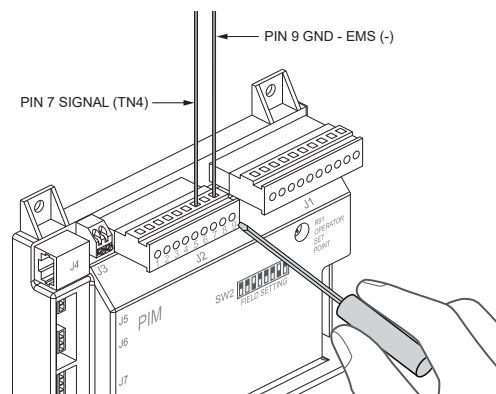

Figure 58. TN_Bus Wire Connection

11.4. Cascade Topology

The VERSA IC system supports multiple cascade combinations, whether is 1 to 4 FT_bus units, and 1 to 4 TN units, all 4 FT_bus or no TN_bus units, or all 4 TN_bus and no FT_bus units.

See **Figure 61** through **Figure 63** showing different typical cases.

11.4.1. Cascade System Pump and Sensor Wiring

1. On the boiler designated as the Master, connect the system pump wiring to the system pump output terminals. The output is rated for pilot duty only (2A maximum).
2. For system pump operation during limp-along mode, it is recommended to connect the system pump outputs from each unit in parallel. See "**Parallel Pump Wiring Description**" on page 56.
3. Connect the boiler pump wires to the boiler pump terminals or associated relay, based on model type and size.
4. Connect the system supply sensor to the MASTER, per instructions provided with the unit.
5. Connect the Outdoor Sensor (if used) to the MASTER, per instructions provided with the unit.
6. Connect the Enable/Disable wiring to the Master. This connection must be provided through dry contacts closure. For each follower to be operational during limp-along mode the enable must be jumpered at each unit.

NOTE: This dry contacts closure can come from a room thermostat or a remote relay. No power of any kind should be applied to either of these terminals.

11.4.2. Cascade Follower Pump and Sensor Wiring

1. Once the Master has been identified, additional boilers will be designated as Followers. DIP switch #2 on each follower VERSA Control Board must be set to the OFF/Down position.
2. For each follower boiler, connect the boiler pump wires to the terminal block at the rear of each unit. Connect to terminals 4, 5, and 6.
3. The System pump and DHW pump outputs may be configured for use during limp-along mode. See "**Parallel Pump Wiring Description**" on page 56.

11.4.3. Alarm Connection

An alarm bell or light may be connected to the alarm contacts on the boiler PIM. The Alarm Contacts are 3A rated dry contacts on a normally-open relay that closes during fault or lockout conditions, and the maximum voltage across the contacts is 30 VAC or 30 VDC.

Connections are made at J1 pins 1 and 2 on the boiler PIM. In a cascade system, the alarm output of all connected units will be active if either the master boiler or follower(s) have a lockout condition. If the Cascade Alarm feature is enabled on the Master unit.

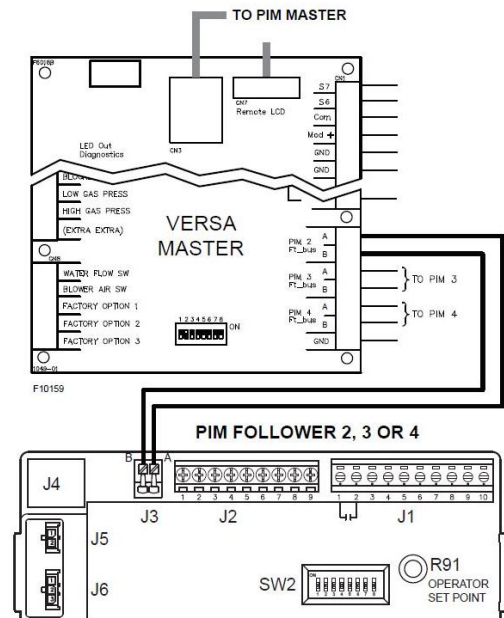

Figure 59. FT_Bus Cascade System Wiring

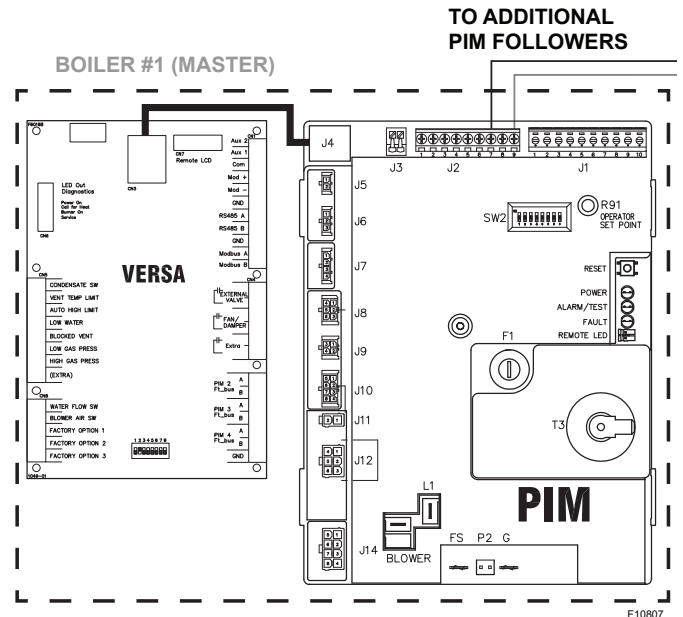

Figure 60. TN_Bus Cascade System Wiring

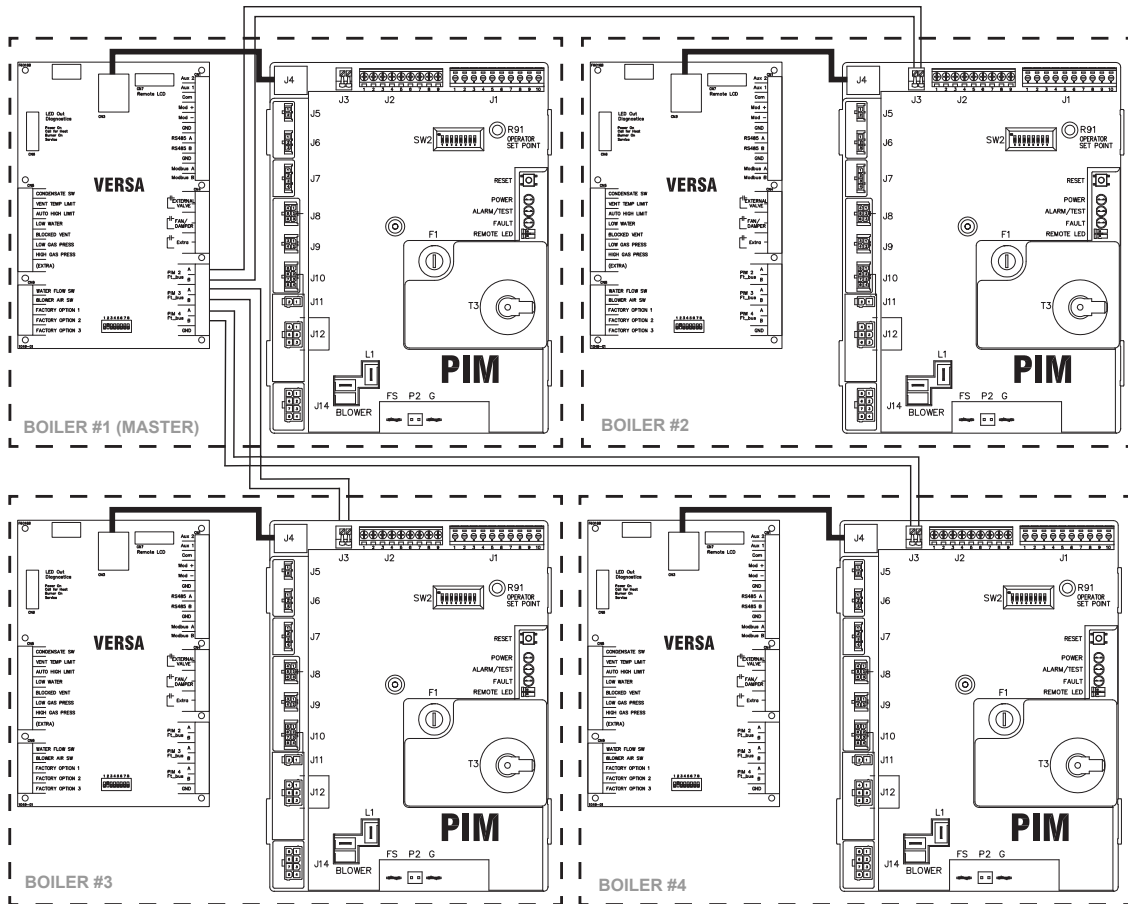

Figure 61. Cascade Configuration - Master + 3 FT_Bus Wire Connection

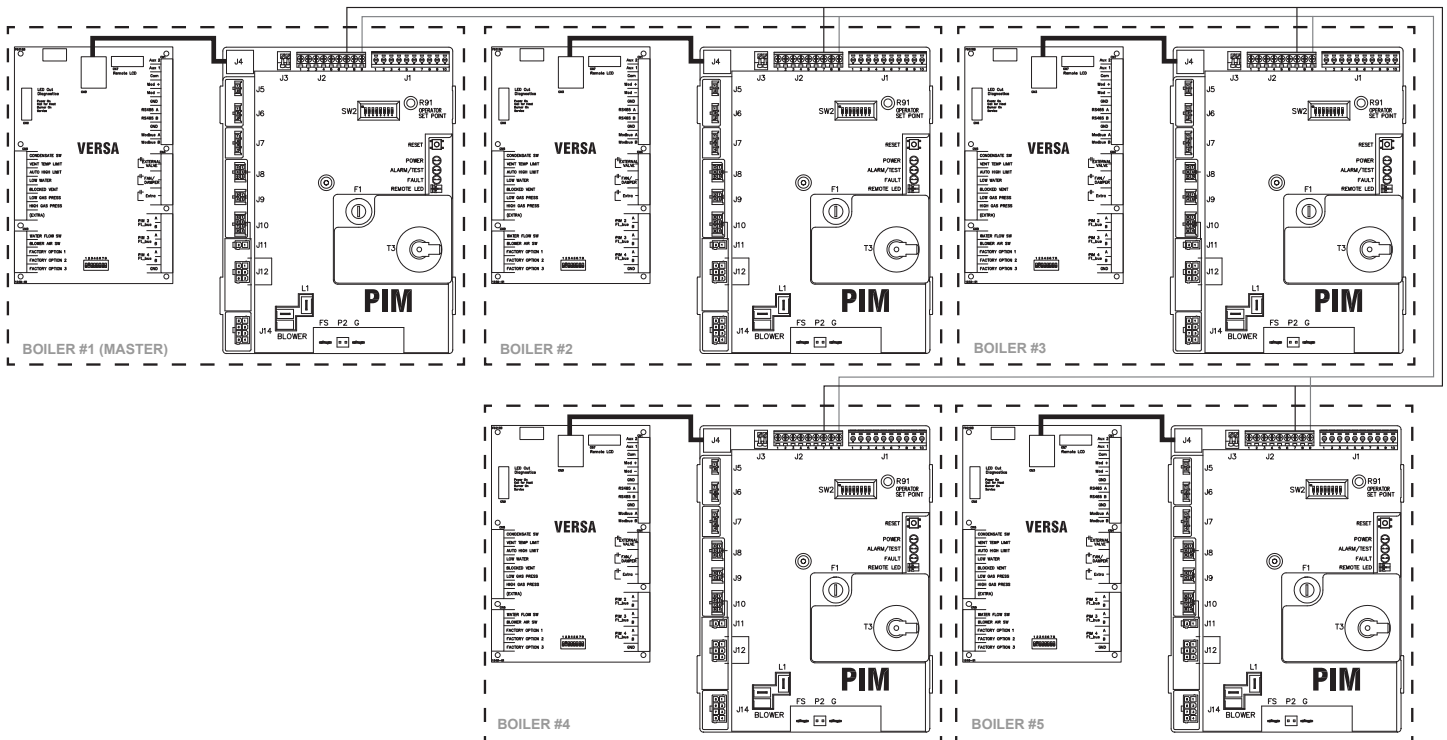

Figure 62. Cascade Configuration - Master + 4 TN_Bus Wire Connection

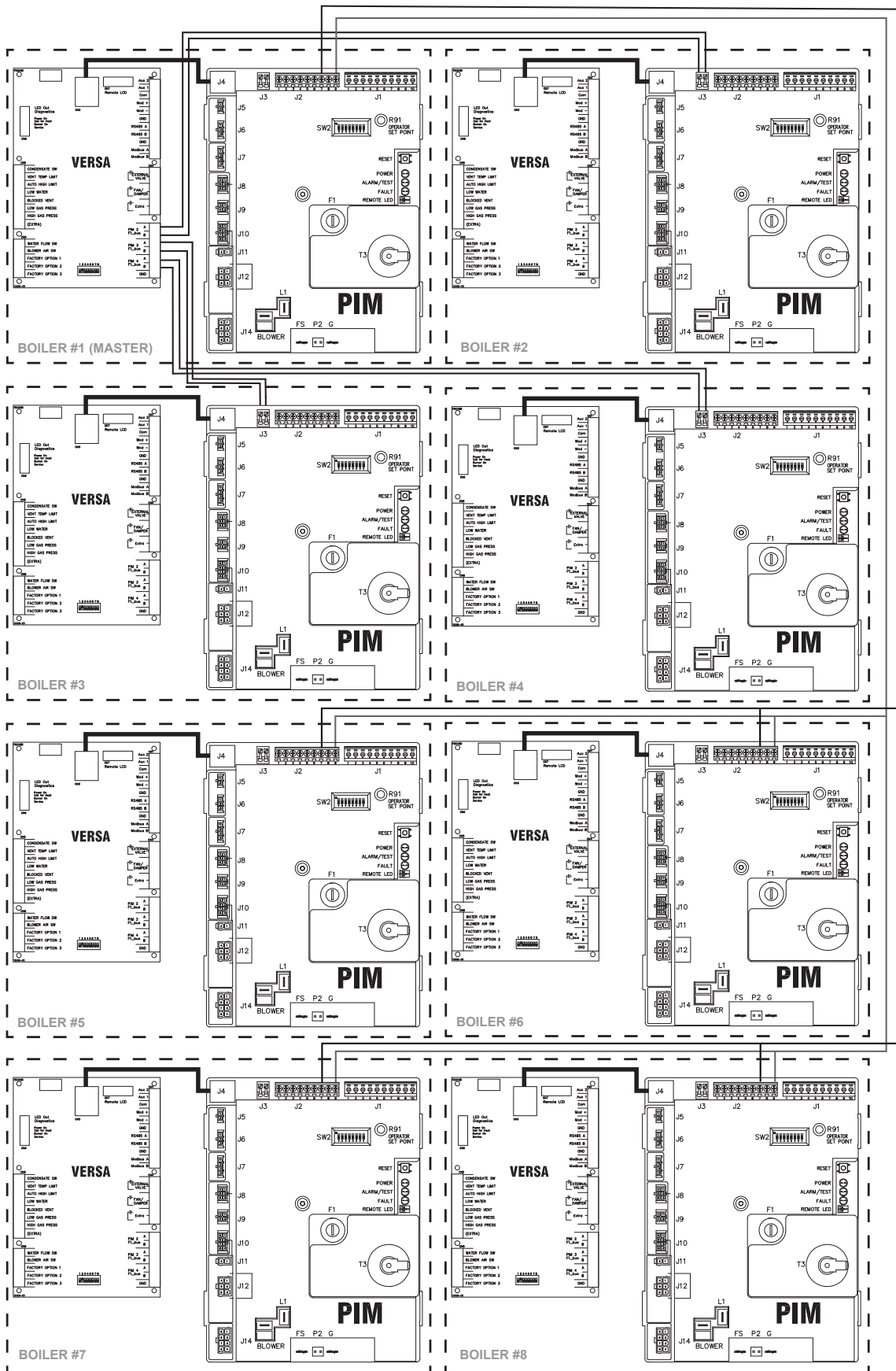

Figure 63. Cascade Configuration - Master + 3 FT_Bus + 4 TN_Bus Wire Connection

INPUT SIGNAL VDC	XFIIRE / IFIRE/ XPAK FT		XVERS / XVERS L XVERS KOR	MVB / XTHERM / HI-DELTA			INPUT SIGNAL mA	EXAMPLE	
	BOILER °F/°C	WATER HEATER °F/°C	BOILER °F/°C	BOILER °F/°C	WATER HEATER °F/°C	POOL HEATER* °F/°C		Target Min 140°F/60°C	Target Max 180°F/82°C
10.0	192°F/ 89°C	High-Temp Application. Use a Boiler	180°F/ 82°C	220°F/ 105°C	High-Temp Application. Use a Boiler	106°F/ 41.1°C	20.0	180°F/ 82°C	
9.9	190°F/ 88°C		179°F/ 81°C	218°F/ 103°C		106°F/ 40.8°C	19.8	180°F/ 82°C	
9.8	189°F/ 87°C		177°F/ 80°C	216°F/ 102°C		105°F/ 40.5°C	19.7	180°F/ 82°C	
9.7	187°F/ 86°C		176°F/ 79°C	214°F/ 101°C		105°F/ 40.1°C	19.5	179°F/ 81°C	
9.6	186°F/ 85°C		174°F/ 79°C	213°F/ 100°C		104°F/ 39.8°C	19.4	179°F/ 81°C	
9.5	184°F/ 85°C		173°F/ 78°C	211°F/ 99°C		103°F/ 39.4°C	19.2	178°F/ 81°C	
9.4	183°F/ 84°C		171°F/ 77°C	209°F/ 98°C		103°F/ 39.1°C	19.0	178°F/ 81°C	
9.3	181°F/ 83°C		170°F/ 77°C	207°F/ 97°C		102°F/ 38.7°C	18.9	177°F/ 80°C	
9.2	179°F/ 82°C		168°F/ 76°C	205°F/ 96°C		102°F/ 38.4°C	18.7	177°F/ 80°C	
9.1	178°F/ 81°C		167°F/ 75°C	203°F/ 95°C		101°F/ 38°C	18.6	176°F/ 80°C	
9.0	176°F/ 80°C		166°F/ 74°C	201°F/ 94°C		100°F/ 37.7°C	18.4	176°F/ 80°C	
8.9	175°F/ 79°C		164°F/ 73°C	199°F/ 93°C		100°F/ 37.3°C	18.2	176°F/ 79°C	
8.8	173°F/ 78°C		163°F/ 73°C	197°F/ 92°C		99°F/ 37°C	18.1	175°F/ 79°C	
8.7	171°F/ 77°C		161°F/ 72°C	196°F/ 91°C		98°F/ 36.7°C	17.9	175°F/ 79°C	
8.6	170°F/ 77°C		160°F/ 71°C	194°F/ 90°C		98°F/ 36.3°C	17.8	174°F/ 79°C	
8.5	168°F/ 76°C		158°F/ 70°C	192°F/ 89°C		97°F/ 36°C	17.6	174°F/ 78°C	
8.4	167°F/ 75°C		157°F/ 70°C	190°F/ 88°C		97°F/ 35.6°C	17.4	173°F/ 78°C	
8.3	165°F/ 74°C		155°F/ 68°C	188°F/ 87°C		96°F/ 35.3°C	17.3	173°F/ 78°C	
8.2	164°F/ 73°C	154°F/ 68°C	186°F/ 86°C	95°F/ 34.9°C	17.1	172°F/ 78°C			
8.1	162°F/ 72°C	160°F/ 71°C	153°F/ 67°C	184°F/ 85°C	160°F/ 71°C	95°F/ 34.6°C	17.0	172°F/ 78°C	
8.0	160°F/ 71°C	159°F/ 71°C	151°F/ 66°C	182°F/ 84°C	159°F/ 71°C	94°F/ 34.2°C	16.8	172°F/ 77°C	
7.9	159°F/ 70°C	157°F/ 69°C	150°F/ 66°C	180°F/ 82°C	157°F/ 69°C	93°F/ 33.9°C	16.6	171°F/ 77°C	
7.8	157°F/ 70°C	156°F/ 69°C	148°F/ 64°C	179°F/ 81°C	156°F/ 69°C	93°F/ 33.5°C	16.5	171°F/ 77°C	
7.7	156°F/ 69°C	154°F/ 68°C	147°F/ 64°C	177°F/ 80°C	154°F/ 68°C	92°F/ 33.2°C	16.3	170°F/ 77°C	
7.6	154°F/ 68°C	153°F/ 67°C	145°F/ 63°C	175°F/ 79°C	153°F/ 67°C	92°F/ 32.9°C	16.2	170°F/ 76°C	
7.5	153°F/ 67°C	151°F/ 66°C	144°F/ 62°C	173°F/ 78°C	151°F/ 66°C	91°F/ 32.5°C	16.0	169°F/ 76°C	
7.4	151°F/ 66°C	150°F/ 66°C	142°F/ 61°C	171°F/ 77°C	150°F/ 66°C	90°F/ 32.2°C	15.8	169°F/ 76°C	
7.3	149°F/ 65°C	148°F/ 64°C	141°F/ 61°C	169°F/ 76°C	148°F/ 64°C	90°F/ 31.8°C	15.7	168°F/ 76°C	
7.2	148°F/ 64°C	146°F/ 63°C	140°F/ 60°C	167°F/ 75°C	146°F/ 63°C	89°F/ 31.5°C	15.5	168°F/ 75°C	
7.1	146°F/ 63°C	145°F/ 63°C	138°F/ 59°C	165°F/ 74°C	145°F/ 63°C	88°F/ 31.1°C	15.4	168°F/ 75°C	
7.0	145°F/ 63°C	143°F/ 62°C	137°F/ 58°C	163°F/ 73°C	143°F/ 62°C	88°F/ 30.8°C	15.2	167°F/ 75°C	
6.9	143°F/ 62°C	142°F/ 61°C	135°F/ 57°C	162°F/ 72°C	142°F/ 61°C	87°F/ 30.4°C	15.0	167°F/ 75°C	
6.8	142°F/ 61°C	140°F/ 60°C	134°F/ 56°C	160°F/ 71°C	140°F/ 60°C	87°F/ 30.1°C	14.9	166°F/ 74°C	
6.7	140°F/ 60°C	139°F/ 59°C	132°F/ 56°C	158°F/ 70°C	139°F/ 59°C	86°F/ 29.7°C	14.7	166°F/ 74°C	
6.6	138°F/ 59°C	137°F/ 58°C	131°F/ 55°C	156°F/ 69°C	137°F/ 58°C	85°F/ 29.4°C	14.6	165°F/ 74°C	
6.5	137°F/ 58°C	136°F/ 58°C	129°F/ 54°C	154°F/ 68°C	136°F/ 58°C	85°F/ 29.1°C	14.4	165°F/ 74°C	
6.4	135°F/ 57°C	134°F/ 57°C	128°F/ 53°C	152°F/ 67°C	134°F/ 57°C	84°F/ 28.7°C	14.2	164°F/ 73°C	
6.3	134°F/ 56°C	132°F/ 56°C	127°F/ 53°C	150°F/ 66°C	132°F/ 56°C	83°F/ 28.4°C	14.1	164°F/ 73°C	
6.2	132°F/ 56°C	131°F/ 55°C	125°F/ 52°C	148°F/ 65°C	131°F/ 55°C	83°F/ 28°C	13.9	164°F/ 73°C	
6.1	130°F/ 55°C	129°F/ 54°C	124°F/ 51°C	146°F/ 64°C	129°F/ 54°C	82°F/ 27.7°C	13.8	163°F/ 73°C	
6.0	129°F/ 54°C	128°F/ 53°C	122°F/ 50°C	145°F/ 63°C	128°F/ 53°C	82°F/ 27.3°C	13.6	163°F/ 72°C	
5.9	127°F/ 53°C	126°F/ 52°C	121°F/ 50°C	143°F/ 61°C	126°F/ 52°C	81°F/ 27°C	13.4	162°F/ 72°C	
5.8	126°F/ 52°C	125°F/ 52°C	119°F/ 48°C	141°F/ 60°C	125°F/ 52°C	80°F/ 26.6°C	13.3	162°F/ 72°C	
5.7	124°F/ 51°C	123°F/ 51°C	118°F/ 48°C	139°F/ 59°C	123°F/ 51°C	80°F/ 26.3°C	13.1	161°F/ 72°C	
5.6	123°F/ 50°C	122°F/ 50°C	116°F/ 46°C	137°F/ 58°C	122°F/ 50°C	79°F/ 25.9°C	13.0	161°F/ 71°C	
5.5	121°F/ 49°C	120°F/ 49°C	115°F/ 46°C	135°F/ 57°C	120°F/ 49°C	78°F/ 25.6°C	12.8	160°F/ 71°C	
5.4	119°F/ 49°C	118°F/ 48°C	114°F/ 46°C	133°F/ 56°C	118°F/ 48°C	78°F/ 25.3°C	12.6	160°F/ 71°C	
5.3	118°F/ 48°C	117°F/ 47°C	111°F/ 44°C	131°F/ 55°C	117°F/ 47°C	77°F/ 24.9°C	12.5	160°F/ 71°C	
5.2	116°F/ 47°C	115°F/ 46°C	110°F/ 43°C	129°F/ 54°C	115°F/ 46°C	77°F/ 24.6°C	12.3	159°F/ 70°C	
5.1	115°F/ 46°C	114°F/ 46°C	109°F/ 43°C	127°F/ 53°C	114°F/ 46°C	76°F/ 24.2°C	12.2	159°F/ 70°C	

Table P. VERSA Setpoint 0-10 VDC / 4 - 20 mA Operation

INPUT SIGNAL VDC	XFIIRE / IFIRE/ XPAK FT		XVERS / XVERS L XVERS KOR	MVB / XTHERM / HI-DELTA			INPUT SIGNAL mA	EXAMPLE	
	BOILER °F/°C	WATER HEATER °F/°C	BOILER °F/°C	BOILER °F/°C	WATER HEATER °F/°C	POOL HEATER* °F/°C		Target Min 140°F/60°C	Target Max 180°F/82°C
5.0	113°F/ 45°C	112°F/ 44°C	108°F/ 42°C	126°F/ 52°C	112°F/ 44°C	75°F/ 23.9°C	12.0	158°F/ 70°C	
4.9	112°F/ 44°C	111°F/ 44°C	106°F/ 41°C	124°F/ 51°C	111°F/ 44°C	75°F/ 23.5°C	11.8	158°F/ 70°C	
4.8	110°F/ 43°C	109°F/ 43°C	105°F/ 41°C	122°F/ 50°C	109°F/ 43°C	74°F/ 23.2°C	11.7	157°F/ 69°C	
4.7	108°F/ 42°C	108°F/ 42°C	103°F/ 40°C	120°F/ 49°C	108°F/ 42°C	74°F/ 22.8°C	11.5	157°F/ 69°C	
4.6	107°F/ 42°C	106°F/ 41°C	102°F/ 39°C	118°F/ 48°C	106°F/ 41°C	73°F/ 22.5°C	11.4	156°F/ 69°C	
4.5	105°F/ 41°C	104°F/ 40°C	101°F/ 38°C	116°F/ 47°C	104°F/ 40°C	72°F/ 22.1°C	11.2	156°F/ 69°C	
4.4	104°F/ 40°C	103°F/ 39°C	99°F/ 37°C	114°F/ 46°C	103°F/ 39°C	72°F/ 21.8°C	11.0	156°F/ 68°C	
4.3	102°F/ 39°C	101°F/ 38°C	98°F/ 37°C	112°F/ 45°C	101°F/ 38°C	71°F/ 21.5°C	10.9	155°F/ 68°C	
4.2	101°F/ 38°C	100°F/ 38°C	96°F/ 35°C	110°F/ 44°C	100°F/ 38°C	70°F/ 21.1°C	10.7	155°F/ 68°C	
4.1	99°F/ 37°C	98°F/ 37°C	95°F/ 35°C	109°F/ 43°C	98°F/ 37°C	70°F/ 20.8°C	10.6	154°F/ 68°C	
4.0	97°F/ 36°C	97°F/ 36°C	93°F/ 34°C	107°F/ 42°C	97°F/ 36°C	69°F/ 20.4°C	10.4	154°F/ 67°C	
3.9	96°F/ 35°C	95°F/ 35°C	92°F/ 33°C	105°F/ 40°C	95°F/ 35°C	69°F/ 20.1°C	10.2	153°F/ 67°C	
3.8	94°F/ 35°C	94°F/ 34°C	90°F/ 32°C	103°F/ 39°C	94°F/ 34°C	68°F/ 19.7°C	10.1	153°F/ 67°C	
3.7	93°F/ 34°C	92°F/ 33°C	89°F/ 32°C	101°F/ 38°C	92°F/ 33°C	67°F/ 19.4°C	9.9	152°F/ 67°C	
3.6	91°F/ 33°C	90°F/ 32°C	88°F/ 31°C	99°F/ 37°C	90°F/ 32°C	67°F/ 19°C	9.8	152°F/ 66°C	
3.5	89°F/ 32°C	89°F/ 32°C	86°F/ 30°C	97°F/ 36°C	89°F/ 32°C	66°F/ 18.7°C	9.6	152°F/ 66°C	
3.4	88°F/ 31°C	87°F/ 31°C	86°F/ 30°C	95°F/ 35°C	87°F/ 31°C	65°F/ 18.3°C	9.4	151°F/ 66°C	
3.3	86°F/ 30°C	86°F/ 30°C	85°F/ 29°C	93°F/ 34°C	86°F/ 30°C	65°F/ 18°C	9.3	151°F/ 66°C	
3.2	85°F/ 29°C	84°F/ 29°C	83°F/ 29°C	92°F/ 33°C	84°F/ 29°C	64°F/ 17.7°C	9.1	150°F/ 65°C	
3.1	83°F/ 28°C	83°F/ 28°C	80°F/ 27°C	90°F/ 32°C	83°F/ 28°C	64°F/ 17.3°C	9.0	150°F/ 65°C	
3.0	82°F/ 28°C	81°F/ 27°C	79°F/ 26°C	88°F/ 31°C	81°F/ 27°C	63°F/ 17°C	8.8	149°F/ 65°C	
2.9	80°F/ 27°C	80°F/ 27°C	77°F/ 25°C	86°F/ 30°C	80°F/ 27°C	62°F/ 16.6°C	8.6	149°F/ 65°C	
2.8	78°F/ 26°C	78°F/ 26°C	76°F/ 24°C	84°F/ 29°C	78°F/ 26°C	62°F/ 16.3°C	8.5	148°F/ 64°C	
2.7	77°F/ 25°C	76°F/ 24°C	75°F/ 24°C	82°F/ 28°C	76°F/ 24°C	61°F/ 15.9°C	8.3	148°F/ 64°C	
2.6	75°F/ 24°C	75°F/ 24°C	73°F/ 23°C	80°F/ 27°C	75°F/ 24°C	60°F/ 15.6°C	8.2	148°F/ 64°C	
2.5	74°F/ 23°C	73°F/ 23°C	72°F/ 22°C	78°F/ 26°C	73°F/ 23°C	60°F/ 15.2°C	8.0	147°F/ 64°C	
2.4	72°F/ 22°C	72°F/ 22°C	70°F/ 21°C	76°F/ 25°C	72°F/ 22°C	59°F/ 14.9°C	7.8	147°F/ 63°C	
2.3	71°F/ 21°C	70°F/ 21°C	69°F/ 21°C	75°F/ 24°C	70°F/ 21°C	59°F/ 14.5°C	7.7	146°F/ 63°C	
2.2	69°F/ 21°C	69°F/ 21°C	67°F/ 19°C	73°F/ 23°C	69°F/ 21°C	58°F/ 14.2°C	7.5	146°F/ 63°C	
2.1	67°F/ 20°C	67°F/ 19°C	66°F/ 19°C	71°F/ 22°C	67°F/ 19°C	57°F/ 13.9°C	7.4	145°F/ 63°C	
2.0	66°F/ 19°C	66°F/ 19°C	64°F/ 18°C	69°F/ 21°C	66°F/ 19°C	57°F/ 13.5°C	7.2	145°F/ 62°C	
1.9	64°F/ 18°C	64°F/ 18°C	63°F/ 17°C	67°F/ 19°C	64°F/ 18°C	56°F/ 13.2°C	7.0	144°F/ 62°C	
1.8	63°F/ 17°C	62°F/ 17°C	62°F/ 17°C	65°F/ 18°C	62°F/ 17°C	55°F/ 12.8°C	6.9	144°F/ 62°C	
1.7	61°F/ 16°C	61°F/ 16°C	60°F/ 16°C	63°F/ 17°C	61°F/ 16°C	55°F/ 12.5°C	6.7	144°F/ 62°C	
1.6	60°F/ 15°C	59°F/ 15°C	59°F/ 15°C	61°F/ 16°C	59°F/ 15°C	54°F/ 12.1°C	6.6	143°F/ 61°C	
1.5	58°F/ 14°C	58°F/ 14°C	57°F/ 14°C	59°F/ 15°C	58°F/ 14°C	54°F/ 11.8°C	6.4	143°F/ 61°C	
1.4	56°F/ 14°C	56°F/ 13°C	56°F/ 13°C	58°F/ 14°C	56°F/ 13°C	53°F/ 11.4°C	6.2	142°F/ 61°C	
1.3	55°F/ 13°C	55°F/ 13°C	54°F/ 13°C	56°F/ 13°C	55°F/ 13°C	52°F/ 11.1°C	6.1	142°F/ 61°C	
1.2	53°F/ 12°C	53°F/ 12°C	53°F/ 12°C	54°F/ 12°C	53°F/ 12°C	52°F/ 10.7°C	5.9	141°F/ 60°C	
1.1	52°F/ 11°C	52°F/ 11°C	51°F/ 11°C	52°F/ 11°C	52°F/ 11°C	51°F/ 10.4°C	5.8	141°F/ 60°C	
1.0	50°F/ 10°C	50°F/ 10°C	50°F/ 10°C	50°F/ 10°C	50°F/ 10°C	50°F/ 10°C	5.6	140°F/ 60°C	
0.9	Boiler Idle						81°F/ 27°C	* Setpoints above 104°F (40°C) are only available if the setpoint range has been extended in the field. See "Pool Setpoint (POOL SETP)" on page 42.	
0.8							80°F/ 26.6°C		
0.7	System Pump Enable						80°F/ 26.3°C		
0.6						79°F/ 25.9°C			
0.5	System Pump Disable						78°F/ 25.6°C		
0.4							78°F/ 25.3°C		
0.3							77°F/ 24.9°C		
0.2	System Offline						77°F/ 24.6°C		
0.1							76°F/ 24.2°C		
0.0							75°F/ 23.9°C		

Table P VERSA Setpoint 0-10 VDC / 4 - 20 mA Operation (Cont.)

12. “LIMP-ALONG” OPERATION OF PIM

The VERSA IC PIM is fully capable of “limp-along” operation of the heater should anything happen to the VERSA Control board or the communications between the PIM and VERSA Control board.

NOTE: The PIM reverts to “limp-along” operation whenever communication with the VERSA Control Board is lost for more than 30-seconds or if the VERSA Control is not found on the communications bus during power up.

The Operator Setpoint potentiometer on the PIM is used to control the Operating Setpoint at the outlet sensor during limp-along operation. See **Figure 61**.

This is the target outlet temperature used in the firing rate calculations. The maximum target setpoint for boiler models of XVers / XVers L / XVers with KOR will be 180°F (82°C), XFiire / IFire / XPak-FT will be 192°F (89°C), and MVB / XTherm will be limited to 220°F (105°C). Water heater models will be limited to 160°F (71°C) regardless of the potentiometer position. P models have a maximum setpoint of 104°F (40°C), or 106°F (41°C) if the range has been extended. See **“Pool Setpoint (POOL SETP)” on page 42**.

The PIM calculates the required firing rate or stage demand using the heater inlet and outlet sensor inputs and the target setpoint from the operator potentiometer setting. The algorithm uses the boiler mass and other parameter settings to refine the firing rate for optimal setpoint control. Full auto-differential capability is retained when enabled using DIP switch #1 on the PIM.

The PIM will respond to a DHW call signal on the field wiring terminals. The DHW pump is activated and the temperature is controlled to the operating setpoint of the potentiometer. The boiler pump will be activated whenever there is a CFH to satisfy target temperature.

NOTE: Direct DHW (Mode 1) and Indirect DHW (Mode 2 or Mode 3) configuration require that all PIM operator dials be set to DHW Target temperature to prevent an over-temp condition from occurring during “Limp-Along”.

12.1. Limitations During PIM “Limp-Along” Operation

1. Diagnostic information is limited to the alarm relay and red LED flash codes on the PIM, and will only be displayed if the VERSA Control Board on the unit has failed.
2. System Sensor operation is NOT supported.
3. DHW Sensor operation is NOT supported.
4. Outdoor Sensor and Outdoor Reset functions are NOT supported.

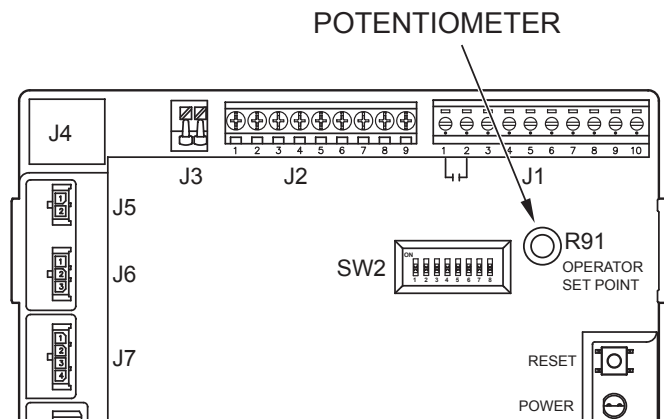

Figure 64. PIM Potentiometer Location

13. TROUBLESHOOTING

Before troubleshooting the system, ensure that:

- Ensure units are properly installed per the instructions provided in the installation and operation manual for the unit being serviced.
- All mechanical and electrical connections are secure and tight.
- All system wiring is correct.
- A system ground is properly connected to the heater (The igniter, flame sensor and ignition module must share a common ground with the burner. Nuisance shutdowns are often caused by a poor or erratic ground.)
- Isolate the system from any other hardware application, reset the PIM and restore defaults on the VERSA board. See **“Restoring VERSA IC to Factory Defaults” on page 72**.
- The system is powered and the unit is enabled (TH).

The PIM is equipped with an on-board buss-type fuse (T8AL250VP) to protect the 24VAC circuits and the 24VAC relay outputs to the gas valves. ONLY use a type GMA fuse (8 Amp max) as a replacement for proper operation.

Fault codes are displayed on the VERSA IC Display. Many of these fault codes are also displayed by a flashing red LED on the PIM module. The number of flashes indicates the fault – see **Table P through Table R** for explanation of the flash codes and troubleshooting recommendations. Any failure in the standard safety chain is reported as a general fault.

If the VERSA IC Display is showing an error/fault code, troubleshoot as noted in **Table S** and **Table T**.

Error Mode	LED Flash Code on PIM	Recommended Troubleshooting
Normal Operation	Red LED OFF	
ID Card Fault	Red LED Steady ON, Green Power LED OFF	Check that the proper ID Card is securely connected. Perform a power and system reset
Internal Control Fault	Red LED Steady ON	Perform a power and system reset. If the fault remains, replace the PIM
Airflow Fault	Red LED – 1 Flash	Check blower operation and air flow switch
False Flame Error	Red LED – 2 Flashes	Check for proper gas valve closure. Clean burner and electrodes
Ignition Lockout Fault	Red LED – 3 Flashes	Check the gas supply. Check transformer. Check igniters. Check wiring. Press reset button on PIM/membrane switch. Recycle power
Ignition Proving Current Fault	Red LED – 4 Flashes	Check HSI element (for those models equipped with a hot surface igniter). Replace as necessary
Low Voltage Fault	Red LED – 5 Flashes	Check the 24VAC input voltage – the voltage must be above 18.0VAC for proper operation. Replace transformer as necessary
Vent Temperature Fault	Red LED – 6 Flashes	(If equipped with Vent sensor)Check for a blocked flue. Check the vent sensor and wiring. Check vent connections and vent system. If damage is observed, contact a qualified installer to have the vent system properly inspected and repaired as necessary
Hi-Limit Fault	Red LED – 7 Flashes	Check for proper water flow. Check hi-limit setting and outlet sensor
Sensor Fault	Red LED – 8 Flashes	Check the VERSA IC for fault identification. Check sensor and wiring
N/A	Red LED – 9 Flashes	Check wiring at J8, pins 1 & 3 for loose or missing jumper
Water Pressure Fault	Red LED – 10 Flashes	Check system piping for leaks. Check water pressure switch (if equipped) and connections. Check wiring on PIM at J1, pins 6 & 7 for loose or missing jumper
Blower Speed Fault	Red LED – 11 Flashes	Verify the tachometer signal and the connections at terminals J10 on the PIM. Confirm power to boiler is at or above minimum required
N/A	Red LED – 12 Flashes	Check wiring on PIM at J1, pins 3 and 4 for loose or missing jumper
Hi-Temperature Delta Fault	Red LED – 13 Flashes	Check pump operation. Confirm proper water flow across heat exchanger (Delta-T)
Ft_bus Communications Fault	Red LED – 14 Flashes	Verify that the VERSA IC is connected and operating properly. Check the cable between the PIM and the VERSA IC
General Limit Circuit Fault	Red LED – 15 Flashes	Check the VERSA IC for fault indication and troubleshooting information

Table Q. LED Flash Codes on PIM

Fault ID	Item/Description	Fault Condition	LED Code (Flashes)
1	Airflow Fault	Open or close fault	1
2	Flame Error	False flame signal	2
3	Hard Lockout	Ignition Lockout	3
4	Ignition Proving Current fault	HSI Element current not in range	4
5	Low Voltage Fault	Voltage below 18.0Vac	5
6	Vent Temperature Fault	High Vent temperature reached	6
7	Hi-Limit Fault	Hi-Limit Reached	7
9	Safety #1 Fault	Safety input fault detected	9
10	Water flow Fault	Open or close fault	10
11	Blower Speed Fault	RPM out of expected range	11
12	LWCO Fault	LWCO Open	12
13	Hi-Delta-Temp Fault	Delta-T exceeds threshold	13
14	Ft_Bus Comm Fault	Loss of Communications	14
15	ID Card Fault	Invalid or Missing card	Red On, Green Off
16	Outlet Sensor Fault	Open/short	8
17	Inlet Sensor Fault	Open/short	8
18	Hi-Limit Sensor Fault	Open/short or mismatch to outlet	8
19	Vent Sensor Fault	Open/short	8
20	Safety #2 Fault	Safety input fault detected	15

NOTE: The Secondary PIM monitors the Primary PIM Fault status and energizes the Alarm Relay when any Fault ID is indicated.

Table R. Primary PIM Faults, Hi-Delta Only

Fault ID	Item/Description	Fault Condition	LED Code (Flashes)
1	Airflow Fault	Open or close fault	
2	Flame Error	False flame signal	2
3	Hard Lockout	Ignition Lockout	3
4	Ignition Proving Current fault	HSI Element current not in range	4
5	Low Voltage Fault	Voltage below 18.0Vac	5
6	Vent Temperature Fault	High Vent temperature reached	
7	Hi-Limit Fault	Hi-Limit Reached	
9	Safety #1 Fault	Safety input fault detected	
10	Water flow Fault	Open or close fault	
11	Blower Speed Fault	RPM out of expected range	11
12	Interlock Fault	Interlock Open	12
13	Hi-Delta-Temp Fault	Delta-T exceeds threshold	
14	Ft_Bus Comm Fault	Loss of Communications	14
15	ID Card Fault	Invalid or Missing card	Red On, Green Off
16	Outlet Sensor Fault	open/short	
17	Inlet Sensor Fault	open/short	
18	Hi-Limit Sensor Fault	open/short or mismatch to outlet	
19	Vent Sensor Fault	open/short	
20	Safety #2 Fault	Safety input fault detected	

NOTE: The Secondary PIM energizes the Alarm Relay when any Fault ID is indicated.

Table S. Secondary PIM Faults, Hi-Delta Only

Error Message	Description	Recommended Troubleshooting
OUTLET SEN	Heater outlet sensor fault, 3-sec delay	Check outlet sensor Check outlet sensor wiring
LIMIT SEN	High limit sensor fault, 3-sec delay	Check limit sensor Check limit sensor wiring
INLET SEN	Heater inlet sensor fault, 3-sec delay	Check inlet sensor Check inlet sensor wiring
INTERLOCK	Factory-installed jumper in place when shipped, 90-sec delay	Check louver end switch & wiring Check combustion air damper end switch & wiring Check extractor & wiring
WATER PRESS	Water pressure switch fault (if equipped) – Factory-installed jumper in place if not shipped with water pressure switch, 90-sec delay	Verify wiring at J1 terminals 6 & 7 Check heater pump Check isolation valves
AIR PRESS	Air pressure switch fault (if equipped) – Factory-installed jumper in place if not shipped with air pressure switch, 90-sec delay	Verify wiring at J8 terminals 2 & 4 Check blower(s) Check air pressure switch tubing
GAS PRESS	Gas pressure switch fault (if equipped) – Factory-installed jumper in place if not shipped with high pressure switch and/or low gas pressure switch, 90-sec delay	Verify wiring at J8 terminals 1 & 3 Check gas pressure switches Check gas pressure Check gas pressure switch tubing
IGNITION	Ignition fault	Reset ignition control – Push either RESET button on membrane switch or reset button on PIM or recycle power
LIMIT TRIP	Boiler outlet temperature tripped the high limit	Push reset button on high limit control if manual-reset High Limit tripped Wait for water temperature to drop and auto-reset high limit will reset Check pump operation Check bypass (if equipped) for too much water flow
FLAME	Flame detected without call-for-heat, 3-sec delay	Shut-off gas supply Recycle power Check gas valve leakage
ID CARD	Invalid/missing ID Card, 3-sec delay	Connect ID Card mounted in heater Contact the factory if “Invalid ID Card” is noted
IGN CTRL	Internal PIM control fault, 3-sec delay	Recycle power – if error continues to occur, replace PIM
Delta-T	Threshold Delta-T temperature exceeded, 3-sec delay	Check pump operation Check Delta-T setting Check bypass (if equipped) for too much water flow
LO HSI CUR	Low HSI current at PIM control, 3-sec delay	Check HSI current Replace HSI Replace PIM control
LOW 24VAC	Low 24VAC power at PIM control, 3-sec delay	Check power supply Check transformer
BLOW SPEED	Blower speed (rpm) out of range, 3-sec delay	Check power supply Check blower wiring to PIM Check blower type
SAFETY INPUT	Additional factory installed safety fault – see Product Installation and Operation Manual for specific information relating to this, 3-sec delay	Verify wiring at J8 – terminals 5 & 6

Table T. Error messages generated from the PIM but displayed on the VERSA IC Display

Error Message	Timeout	Description	Troubleshooting
CTRL SETUP	3-sec	EEPROM setup block read error at power up. Factory defaults are reloaded. Operation stops until all adjustments are checked.	Check all SETUP items (Restoring factory defaults at VERSA may clear these faults)
SUPPLY ERR	3-sec	System supply sensor is shorted or has an open circuit. The control will cease operation.	Check supply sensor Check supply sensor wiring
DHWSUP ERR	3-sec	Plant sensor is shorted or has an open circuit. The control will cease operation.	Check Aux1 sensor Check Aux 1 sensor wiring
OUTDOOR ERR	3-sec	Outdoor air sensor is shorted or has an open circuit. The control will continue to operate assuming an outdoor temperature of 32°F (0°C)	Check outdoor air sensor Check outdoor air sensor wiring 15 min soft lockout
DHW ERR	3-sec	Indirect DHW sensor is shorted or has an open circuit. The control will cease operation for indirect DHW, but will continue to operate as required for system heating.	Check DHW sensor Check DHW sensor wiring
TANK ERR	3-sec	Tank sensor is shorted or has an open circuit. The control will cease operation.	Check tank sensor Check tank sensor wiring
POOL ERR	3-sec	Pool sensor is shorted or has an open circuit. The control will cease operation.	Check pool sensor Check pool sensor wiring
DEV LOST	3-sec	Device xx on heater bus is lost, if device is on the tN4 bus, the zone is displayed as well.	Check wiring between VERSA IC board and all PIM's on the network Check communication wiring for BMS system
DEV ERR	3-sec	More than 1 master detected on tN4 bus.	Check DIP switches on cascaded heaters to make sure only 1 unit is set to Master while the others are set to Followers/Slave. Check communication wiring at heater with noted address
PIM 1 ERR	3-sec	Communications with PIM 1 were established but then lost.	Check cabling and DIP switch settings for Master/Follower config
PIM 2 ERR	3-sec	Communications with PIM 2 were established but then lost.	Confirm cabling and DIP switch settings.
PIM 3 ERR	3-sec	Communications with PIM 3 were established but then lost.	Confirm cabling and DIP switch settings.
PIM 4 ERR	3-sec	Communications with PIM 4 were established but then lost.	Confirm cabling and DIP switch settings.
CONDENSATE	3-sec	Condensate switch has tripped	Check for blockage of condensate drain Check condensate switch Check condensate switch wiring Check for heat exchanger leak which might overwhelm the capacity of the condensate drain causing this error 15 min soft lockout
VENT TEMP	1-sec	Vent temperature switch has tripped	Check vent temperature switch Check vent temperature switch wiring Check PVC/CPVC/Polypropylene vent for any damage due to excessive temperatures Check vent for leaks near vent temperature switch
AUTO LIMIT	3-sec	Automatic high limit has tripped	Check the automatic high limit switch Check the automatic high limit switch wiring Check for proper pump operation Check bypass (if equipped) for too much water flow 15 min soft lockout
LOW WATER	1-sec	Low water cut-off has tripped	Push reset button on LWCO control Check LWCO probe & wiring
VENT BLOCK	3-sec	Blocked vent switch has tripped	Check venting Check vent pressure switch and wiring Check vent pressure switch tubing 15 min soft lockout
LOW GAS	1-sec	Low gas pressure switch has tripped	Push reset button on low gas pressure switch. Verify proper gas pressure. Open manual gas valves fully. Clean out drip leg
HIGH GAS	1-sec	High gas pressure switch has tripped	Push reset button on high gas pressure switch Verify proper gas pressures
EXTRA	1-sec	Extra limit switch has tripped – see Product Installation and Operation Manual for more detail if this limit is used and how to troubleshoot it.	See product specific Installation and Operation Manual troubleshooting section
WATER FLOW	3-sec	Water flow switch has tripped 10-sec to make, then 1-sec to 'FAULT'	Check heater pump operation Purge air from system Replace flow switch as necessary 15 min soft lockout
BLOWER	10-sec	Blower air pressure switch has tripped	Check air filter. Check blower Check air pressure switch hose. Check wiring 15 min soft lockout
OPTION 1	10-sec	Factory option #1 switch has tripped. This switch uses a 10-sec delay on initial CFH before reporting the fault	Check wiring diagram to determine what is connected here
OPTION 2	30-sec	Factory option #2 switch has tripped. This switch uses a 30-sec delay on initial CFH before reporting the fault	Check wiring diagram to determine what is connected here
OPTION 3	90-sec	Factory option #3 switch has tripped. This switch uses a 90-sec delay on initial CFH before reporting the fault	Check wiring diagram to determine what is connected here Check field interlocks such as combustion air damper proving switch

Table U. Error messages generated from the VERSA Control Board

14. TECHNICAL DATA

Enclosure	Bare board with stand-offs
Power Supply	24 VAC +/- 10%, 60Hz
Safety/Fan/Extra Relays	240VAC, 5A
Modulating Output	0-10 VDC, 3K min. load impedance / 0-20mA
Demands	Connect to 24VAC return to initiate demand
Ambient Conditions	Inside enclosure use ONLY; 32°F to 122°F (0 to 50°C), <90% relative humidity non-condensing

Table V. VERSA Control Board Ratings

Input Power	18-30 VAC 50/60Hz (Class 2 transformer)
Input Current Drain	400mA @ 24VAC with gas and blower relays energized
Gas Valve Relays	5.0A max (continuous)
Combustion Blower	5.0A max for standard (J2) connection 15.0A max for heavy duty (K5 relay) terminals
Hot Surface Igniter	5.0A max, 120/240VAC
Pump Relays	5.0A max (continuous)
Alarm Relay	2.0A, 30VDC or 30VAC max
Operating Temperature	-40 to +176°F (-40 to +80°C)
Storage Temperature	-40 to +185°F (-40 to +85°C)
Flame Sensitivity	0.7 µA minimum
Flame Failure Response or Reignition Time	0.8-seconds minimum
Flame Detector Self-Check Rate	Once per second minimum
Flame Failure Lockout Time	Varies by model
Spark Rate	Remote sense – 50/60Hz; Local sense – 25/30Hz
Moisture Resistance	Conformal coated to operate non-condensing to 95% relative humidity

Table W. PIM Ratings

15. ADDITIONAL TROUBLESHOOTING

15.1. 10k Sensor Resistance Values

Temperature (°F/°C)	Resistance (Ω)
32 / 0	32550
41 / 5	25340
50 / 10	19870
59 / 15	15700
68 / 20	12490
77 / 25	10000
86 / 30	8059
95 / 35	6535
104 / 40	5330
113 / 45	4372
122 / 50	3605
131 / 55	2989
140 / 60	2490
149 / 65	2084
158 / 70	1753
167 / 75	1481
176 / 80	1256
185 / 85	1070
194 / 90	915
203 / 95	786
212 / 100	667

Table X. 10K Sensor resistance values

15.2. Restoring VERSA IC to Factory Defaults

To restore the VERSA IC to factory default settings, on units equipped with keypad interface:

- Using the MENU button scroll to the TOOLBOX menu.
- Use the ITEM button and scroll until you reach the DEFAULTS screen.
- Press and hold the UP and DOWN arrow buttons simultaneously until CLR appears on the screen. The Glycol percentage setting is not affected by this.
- The VERSA IC has been returned to factory default setting. Press the MENU button to return to the ADJUST menu and set the controller for the desired functionality.

To restore the VERSA IC to factory default settings on a touchscreen interface:

- Go to Menu --> Toolbox (Crescent wrench icon)
- Go to System Toolbox
- Press "Defaults" button. See **Figure 38.**)

15.3. Resetting PIM

If the PIM control is moved to another heater, the PIM has to be reset to allow the ID Card to unlock the program parameters and to load them into the PIM memory.

⚠ CAUTION: DO NOT swap a PIM from 1 heater to another heater without resetting the PIM as outlined below.

Follow these steps for a hard reset of the PIM to clear program parameters:

- Remove power from the PIM control.
- Set all DIP switches on the PIM to their OFF position.
- Unplug connector J6 on the PIM control.
- Unplug CAT 5 cable from PIM control.
- Unplug connector J2 on the PIM.
- Press and hold the reset/test button (located next to the LEDs on the right side of the PIM board) while powering the controller for 5-7 seconds.
- The red diagnostic LED will flash indicating the reset process is underway. The PIM board's memory is now clear of any ID Card parameters.
- Release the reset/test button.
- Remove power from the PIM control.
- Connect connector J6 to the PIM control.
- Power up the PIM control.
- If the reset was successful, the green LED shows steady ON.
- If the red and yellow LEDs are ON and the green LED is OFF, the reset was NOT successful.
- If the reset was not successful, repeat steps 1-10.
- If reset was successful, remove power and reset DIP switches for desired operation, reconnect the CAT 5 cable and J2 connector and return the unit to operation.
- Restore VERSA IC to default values, be aware that all configuration will be reset. Verify user settings as necessary.

15.4. Flow Sensor Calibration

NOTE: These instructions apply only to units equipped with a flow sensor. An external reference flow meter is required for this procedure.

⚠ CAUTION: A incorrect sensor calibration can result in heat exchanger damage.

When flow sensor value does not match the actual flow through the unit, follow these steps to perform a flow sensor calibration:

1. Ensure the unit's status is IDLE.
2. Ensure the boiler pump is active (or the isolation valve's position is open).
3. On the touchscreen, go to ADJUST menu, SYSTEM SETTINGS and select FLOW & GLYCOL.
4. Tap 15 times over "FLOW K FACTOR" legend to show the visual aid to get the new K-Factor. See **Figure 65**.

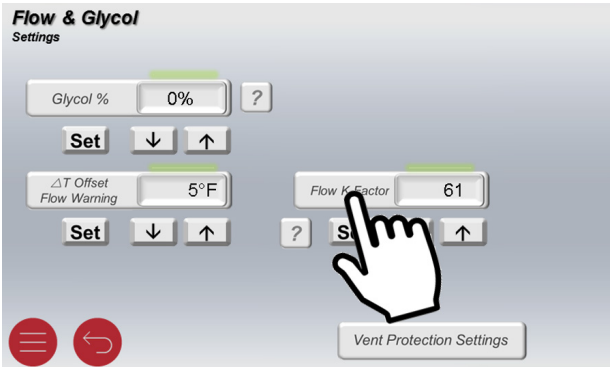

Figure 65. Flow K Factor Settings

5. With your reference flow meter, verify that the flow readings are stable (± 3 GPM).
6. Compare the reference flow meter with unit's flow meter and if there's a discrepancy of more than 15 GPM, set reference flow meter readings in "Corrected Flow Box" using the arrows below it. See **Figure 66**.

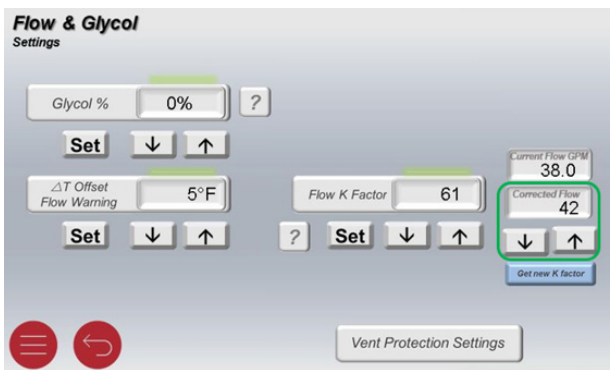

Figure 66. Corrected Flow Box Settings

7. Once the reference flow meter is set, tap "Get new K factor" button to obtain new value. See **Figure 67**.

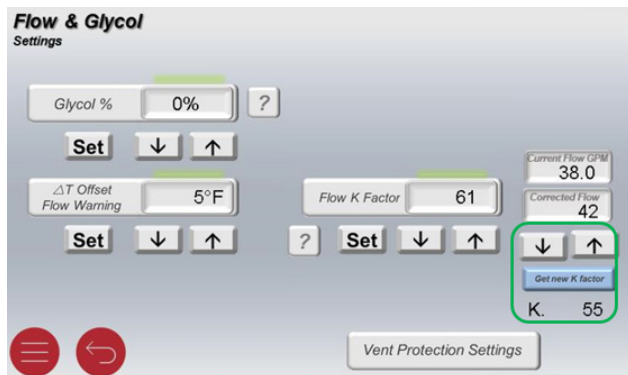

Figure 67. Get New "K Factor" Settings

8. Set the new K Factor using the Up/Down arrows and tap "Set". See **Figure 68**.

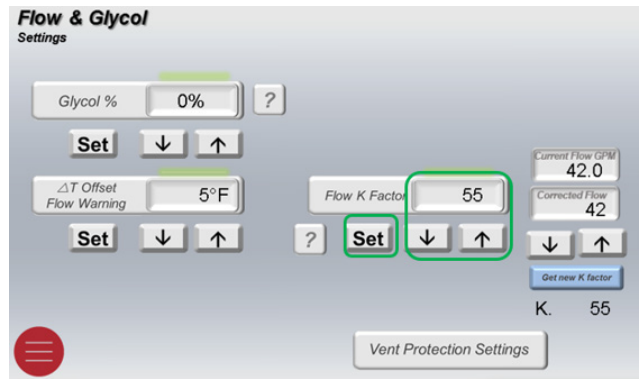

Figure 68. Set New "K Factor" Settings

9. Change will take effect in 1 to 2 minutes after setting new K Factor value.

15.5. Touchscreen Reboot

NOTE: Factory recommends performing a "Screen Reboot" of the touchscreen to ensure all changes display properly.

Follow these steps to perform reboot of the touchscreen interface:

1. Press the MENU button on the touchscreen.
2. Locate and press the TOOLS button.
3. Locate and press the "Screen Reboot" button.
4. Acknowledge reboot is desired.

16. MODBUS PROTOCOL

The VERSA IC support Modbus RTU and ASCII for BMS connection. The available settings are:

1. MODBUS = OFF
 - a. Modbus messages are ignored.
2. MODBUS = MNTR (Monitor Mode)
 - a. The VERSA IC operates as usual, however the Modbus connection allows for remote viewing and adjustment of selected VERSA IC parameters. See **Table AG on page 82**.
3. MODBUS = TEMP (Temperature Control Mode)
 - a. The VERSA IC operates as a slave to a Modbus master control. The Modbus handles all monitor functions and operates the boilers, writing the Target Temp, Sys Pump and DHW Pump data.
 - i. DHW and System Pumps are exclusively turned on and off according to the pump operation sent by the Modbus master control. See **Table AG on page 82**. The VERSA Control Board does not control these pump outputs in this mode.

- ii. Boiler pumps are operated as per usual by the VERSA IC.
- iii. The boiler system is operated to achieve a target temperature sent by the Modbus master control.
 1. A non-zero positive value below target min will be interpreted as target min value.
 2. A zero value will disable the unit
 3. Values within target min and max range will CFH whenever the supply sensor reading is below target.

⚠ CAUTION: Do not use negative integer values.

- 4. MODBUS = RATE (Rate Control Mode)
 - a. The VERSA IC operates as a slave to a Modbus master control. See **Table AG on page 82**.
 - i. Operates as a single-boiler only (no cascade) and writes the target rate data and all pump commands.
 - ii. Pumps are turned on and off according to the pump operation sent by the Modbus master control
 - iii. No system sensor is required. The boiler is operated at the target rate sent by the Modbus master control
 1. A 1 to 100 integer value correspond to a target firing rate from min+1 to 100%.

⚠ CAUTION: Do not use negative integer values.

To enable Modbus with the VERSA IC, you must first turn DIP switch #1 on the VERSA Control Board to the "ON" position to access the Advanced menus. The lock icon on the upper right-hand corner of the VIEW menu will disappear when configured correctly.

From the VIEW menu press the MENU button once to reach the SETUP menu. Using the ITEM button scroll to the Modbus MODE screen and select either MNTR, TEMP or RATE for the functionality desired. From there press the ITEM button to move to the ADDRESS screen, DATA TYPE screen, BAUD RATE screen and then PARITY screen to complete setup for Modbus.

**NOTE: Available ModBus Data Types:
RTU = Remote Terminal Unit
ASCII = ASCII data, not commonly used**

NOTE: ModBus monitor and control temperature values are only available in Fahrenheit.

16.1. Modbus Messaging

This section provides a general overview of the open Modbus protocol for the implementation with the VERSA IC Control Board.

The Modbus protocol is based on the Master / Slave architecture where VERSA IC system acts a slave while the master is a building automation system or a computer equipped with a control / monitoring application, which should be capable of establish communication over a RS-485 serial connection.

16.1.1. Definitions

Acronym	Meaning
LSB	Less Significant Byte
MSB	Most Significant Byte
CRC	Cyclic Redundancy Check
ModBus	A serial, half-duplex data transmission protocol developed by AEG Modicon
HEX	Hexadecimal Representation
RTU	Remote Terminal Unit
BAS	Building Automation System

16.1.2. Minimum System Requirements

In order to establish a communication network under Modbus protocol the following are the basic elements needed:

16.1.3. Hardware:

- BAS System or computer with a serial or USB port.
- USB to RS485 Converter. It is important to ensure the adapter compatible with your system, depending on 32/64 bits and windows type. The adapter used along this documentation is the model: "USB-RS485-WE-5000-BT". Any equivalent may be used.

WARNING: MODBUS topology requires a termination resistor when the Master Control is located far from the unit. Do not use more than one termination resistor and not less 120 Ω.

16.1.4. Software:

There are several open applications available that can be used to monitor and/or control a Modbus network.

16.1.5. Modbus Message Format

The format of Modbus messages changes dramatically between RTU and ASCII data type. The difference between those Modbus data types is that ASCII requires a start and stop character to determine the beginning and end of a message, and also each individual byte from the data stream will be coded with its ASCII representation.

The RTU Format is directly interpreted as HEX values and the starting and stopping point of each message is differentiated by timing delays. It will depend on final user application the selection of the data type. All sub-elements within the Modbus network must have the same data type. The following tables are basic messages to establish Modbus communication with the VERSA Control Board.

16.1.6. READ COMMANDS FOR VERSA IC

Modbus ASCII Message Example							
ASCII (RE-QUEST)	:	ID	Op	Address 2 bytes	Data / Length 2 bytes, each register	LRC 1 byte	CR LF
ASCII	: 0 1 0 4 0 0 0 0 0 0 7 A 8 1 CR LF						
HEX Rep	3A 3031 3033 3030 3642 3030 3033 3831 0D 0A						
Message meaning							
The Message above is calling SLAVE 1, to perform operation 03 = read INPUT register; request address 00hex=00dec; length of data 122 elements = 7A hex, 81 is the LRC value (1+4+0+0+0+7A=7Fhex; the negative representation of -7F hex = FF81, 81 is taken from the lower resulting byte). CR LF is constant for all ASCII messages as well as the ":" at the beginning.							
Message Response: (Message is sent in ASCII and response is ASCII)							
: 0 1 0 4 F 4 0 0 0 0 0 0 0 0 0 0 ... 0 0 0 0 0 0 0 0 0 0 7 A X X CR LF							
Response Meaning:							
The response will echo the request, with the same header Slave Address (1); OP code (04); and byte count = 122 x 2(bytes each data point) = 244 dec = F4 hex; then the 122 consecutive register data points up to 122 points (each data point has 2 bytes); Each Response will also end with the resulting LRC value, and the CR LF.							

Modbus RTU Message Example					
RTU Request)	ID	Op	Ad- dress 2 bytes	Data / Length 2 bytes, each register	CRC 2 bytes
RTU (hex)	01 04 0000 007A 71E9				
Message meaning					
The Message above is calling SLAVE 1, to perform operation 04 = read INPUT register, request address 00dec = 00hex, length of data 122 elements = 7A hex, 71 E9 is the CRC 16bit value (LSB goes first then MSB of the CRC)					
Message Response: (Message is sent directly in HEX values)					
01 04 F4 0000 0000 0000 ... 0000 0000 0000 XXXX					
Response Meaning:					
The response will echo the request, with the same header Slave Address (1); OP code (04); and byte count = 122 x 2(bytes each data point) = 244 dec = F4 hex; then the 122 consecutive register data points up to 122 points (each data point has 2 bytes); Each Response will also end with the resulting LRC value, and the CR LF.					

Status Table	
0	Error Lock
1	Idle
2	Pre-Purge
4	Ignition
8	Burn
16	Post-Purge
32	Ignition Failure
64	Ignition Try 1
128	Ignition Try 2
256	Soft Lock
512	Hard Lock

Table Y. Modbus Boiler Status

ITEM	RANGE	DEFAULT	ACCESS LEVEL	WHEN DISPLAYED	DESCRIPTION
MODBUS	OFF – MNTR – TEMP – RATE	MNTR	Advanced	Always	ModBus Operating Mode: Off, Monitor, Temp Control, Rate Control
ADDRESS	1 to 247	1	Advanced	MODBUS ON	ModBus slave address
DATA TYPE	RTU <> ASCII	RTU	Advanced	MODBUS ON	ModBus data type
BAUD RATE	2400 <> 9600 <> 19K2 <> 57K6 <> 115K	19K2	Advanced	MODBUS ON	
PARITY	NONE - EVEN - ODD	EVEN	Advanced	MODBUS ON	Even/Odd=1 stop bit, None=2 stop bits

Table Z. Modbus Screens

Register	Parameter	Read/Write	Format	Note	Register Address
System Status Registers					
	MODBUS	R	S16	0 = Off, 1 = Monitor, 2 = Temp, 3 = Rate	0
	System Supply Temperature	R	S16		1
	Outdoor Temperature	R	S16		2
	DHW Temperature	R	S16		3
	Aux 1 Temperature	R	S16		4
	Aux 2 Temperature	R	S16		5
	System Pump	R	S16		6
	System Pump Runtime	R	S16		7
	DHW Pump	R	S16		8
	DHW Pump Runtime	R	S16		9
	Setback	R	S16	Only relevant if MODBUS = MNTR	10
	reserved				

Table AA. Modbus System Status Registers

Register	Parameter	Read/Write	Format	Note	Register Address
Boiler 1 Status Registers					
	Boiler1 detected	R	S16	0 = boiler not detected, 1 = boiler detected	16
	Boiler1 On/Off	R/W	S16	0 = offline, 1 = online	1028
	Boiler1 Outlet temperature	R	S16		17
	Boiler1 Inlet temperature	R	S16		18
	Boiler1 Vent temperature	R	S16		19
	Boiler1 High Limit temperature	R	S16		20
	Boiler1 Operator temperature	R	S16		21
	Boiler1 Mod Rate	R	S16	0-100%	22
	Boiler1 Mix Rate	R	S16	not available in initial release	23
	Boiler1 Ignition Status	R	S16	See Table Z	24
	Boiler1 Runtime	R	S16		25
	Boiler1 Cycles	R	S16		26
	Boiler1 Pump	R	S16		27
	Boiler1 Pump Runtime	R	S16		28
	Boiler1 Error Code	R	S16		29
	Boiler1 Error History 1	R	S16		30
	Boiler1 Error History 2	R	S16		31
	Boiler1 Error History 3	R	S16		32
	Boiler1 Error History 4	R	S16		33
	Boiler1 Error History 5	R	S16		34
	Boiler1 Error History 6	R	S16		35
	Boiler1 Error History 7	R	S16		36
	Boiler1 Error History 8	R	S16		37
	Boiler1 Error History 9	R	S16		38
	Boiler1 Error History 10	R	S16		39
	Boiler1 Error History 11	R	S16		40
	Boiler1 Error History 12	R	S16		41
	Boiler1 Error History 13	R	S16		42
	Boiler1 Error History 14	R	S16		43
	Boiler1 Error History 15	R	S16		44
	reserved				

Table AB. Boiler 1 Status Registers

Register	Parameter	Read/Write	Format	Note	Register Address
Boiler 2 Status Registers				MODBUS = MNTR or TEMP	
	Boiler2 detected	R	S16	0 = boiler not detected, 1 = boiler detected	45
	Boiler2 On/Off	R/W	S16	0 = offline, 1 = online	1029
	Boiler2 Outlet temperature	R	S16		46
	Boiler2 Inlet temperature	R	S16		47
	Boiler2 Vent temperature	R	S16		48
	Boiler2 High Limit temperature	R	S16		49
	Boiler2 Operator temperature	R	S16		50
	Boiler2 Mod Rate	R	S16	0-100%	51
	Boiler2 Mix Rate	R	S16	not available in initial release	52
	Boiler2 Ignition Status	R	S16	See Table Z	53
	Boiler2 Runtime	R	S16		54
	Boiler2 Cycles	R	S16		55
	Boiler2 Pump	R	S16		56
	Boiler2 Pump Runtime	R	S16		57
	Boiler2 Error Code	R	S16		58
	Boiler2 Error History 1	R	S16		59
	Boiler2 Error History 2	R	S16		60
	Boiler2 Error History 3	R	S16		61
	Boiler2 Error History 4	R	S16		62
	Boiler2 Error History 5	R	S16		63
	Boiler2 Error History 6	R	S16		64
	Boiler2 Error History 7	R	S16		65
	Boiler2 Error History 8	R	S16		66
	Boiler2 Error History 9	R	S16		67
	Boiler2 Error History 10	R	S16		68
	Boiler2 Error History 11	R	S16		69
	Boiler2 Error History 12	R	S16		70
	Boiler2 Error History 13	R	S16		71
	Boiler2 Error History 14	R	S16		72
	Boiler2 Error History 15	R	S16		73
	reserved				

Table AC. Boiler 2 Status Registers

Register	Parameter	Read/Write	Format	Note	Register Address
Boiler 3 Status Registers				MODBUS = MNTR or TEMP	
	Boiler3 detected	R	S16	0 = boiler not detected, 1 = boiler detected	74
	Boiler3 On/Off	R/W	S16	0 = offline, 1 = online	1030
	Boiler3 Outlet temperature	R	S16		75
	Boiler3 Inlet temperature	R	S16		76
	Boiler3 Vent temperature	R	S16		77
	Boiler3 High Limit temperature	R	S16		78
	Boiler3 Operator temperature	R	S16		79
	Boiler3 Mod Rate	R	S16	0-100%	80
	Boiler3 Mix Rate	R	S16	not available in initial release	81
	Boiler3 Ignition Status	R	S16	See Table Z	82
	Boiler3 Runtime	R	S16		83
	Boiler3 Cycles	R	S16		84
	Boiler3 Pump	R	S16		85
	Boiler3 Pump Runtime	R	S16		86
	Boiler3 Error Code	R	S16		87
	Boiler3 Error History 1	R	S16		88
	Boiler3 Error History 2	R	S16		89
	Boiler3 Error History 3	R	S16		90
	Boiler3 Error History 4	R	S16		91
	Boiler3 Error History 5	R	S16		92
	Boiler3 Error History 6	R	S16		93
	Boiler3 Error History 7	R	S16		94
	Boiler3 Error History 8	R	S16		95
	Boiler3 Error History 9	R	S16		96
	Boiler3 Error History 10	R	S16		97
	Boiler3 Error History 11	R	S16		98
	Boiler3 Error History 12	R	S16		99
	Boiler3 Error History 13	R	S16		100
	Boiler3 Error History 14	R	S16		101
	Boiler3 Error History 15	R	S16		102
	reserved				

Table AD. Boiler 3 Status Registers

Register	Parameter	Read/Write	Format	Note	Register Address
Boiler 4 Status Registers				MODBUS = MNTR or TEMP	
	Boiler4 detected	R	S16	0 = boiler not detected, 1 = boiler detected	103
	Boiler4 On/Off	R/W	S16	0 = offline, 1 = online	1031
	Boiler4 Outlet temperature	R	S16		104
	Boiler4 Inlet temperature	R	S16		105
	Boiler4 Vent temperature	R	S16		106
	Boiler4 High Limit temperature	R	S16		107
	Boiler4 Operator temperature	R	S16		108
	Boiler4 Mod Rate	R	S16	0-100%	109
	Boiler4 Mix Rate	R	S16	not available in initial release	110
	Boiler4 Ignition Status	R	S16	See Table Z	111
	Boiler4 Runtime	R	S16		112
	Boiler4 Cycles	R	S16		113
	Boiler4 Pump	R	S16		114
	Boiler4 Pump Runtime	R	S16		115
	Boiler4 Error Code	R	S16		116
	Boiler4 Error History 1	R	S16		117
	Boiler4 Error History 2	R	S16		118
	Boiler4 Error History 3	R	S16		119
	Boiler4 Error History 4	R	S16		120
	Boiler4 Error History 5	R	S16		121
	Boiler4 Error History 6	R	S16		122
	Boiler4 Error History 7	R	S16		123
	Boiler4 Error History 8	R	S16		124
	Boiler4 Error History 9	R	S16		125
	Boiler4 Error History 10	R	S16		126
	Boiler4 Error History 11	R	S16		127
	Boiler4 Error History 12	R	S16		128
	Boiler4 Error History 13	R	S16		129
	Boiler4 Error History 14	R	S16		130
	Boiler4 Error History 15	R	S16		131
	reserved				

Register	Parameter	Read/Write	Format	Note	Register Address
Boiler 1 Status Register	Flow Sensor	Read	S16	GPM X 10	132
Boiler 2 Status Register	Flow Sensor	Read	S16	GPM X 10	133
Boiler 3 Status Register	Flow Sensor	Read	S16	GPM X 10	134
Boiler 4 Status Register	Flow Sensor	Read	S16	GPM X 10	135

Table AE. Boiler 4 Status Registers

Register	Parameter	Read/Write	Format	Note	Register Address
Monitor Mode Parameter Registers				MODBUS = MNTR	
	CH Call	R	S16		11
	DHW Call	R	S16		12
	Target temperature	R	S16	degF	13
	Target rate	R	S16	Plant target output	14
	Auto Diff	R	S16	(%) 0 = off, 1 = on	15
	Manual Differential	R/W	S16	(only relevant when auto diff is off)	1006
Monitor Mode				MODBUS = MNTR and Space Heating Mode	
	Target Mode	R/W	S16	0 = Reset, 1 = Setpoint	1000
	Setpoint Target	R/W	S16	XVERS/XVERS L/XVERS KOR: 50 to 180°F (10 to 82°C) XPAKFT/XFIIRE/IFIRE Boiler (H): 50 to 192°F (10 to 89°C) Hi DELTA / MVB / XTHERM 50 to 220°F (10 to 89°C)	1001
	Outdoor Start	R/W	S16	35 to 85°F (2 to 30°C)	1002
	Outdoor Design	R/W	S16	-60 to 45°F (-51 to 7°C)	1003
	Boil Start	R/W	S16	35 to 150°F (2 to 66°C)	1004
	Boil Design	R/W	S16	70 to 200°F (21 to 94°C)	1005
	DHW Exchange	R/W	S16	OFF, 70 to 200°F (21 to 94°C)	1007
	DHW Tank	R/W	S16	OFF, 50 to 180°F (10 to 82°C)	1008
	DHW Differential	R/W	S16	2 to 10°F (1 to 24°C)	1009
	DHW Priority	R/W	S16	0 = no DHW priority, 1 = DHW priority	1010
	DHW During UnOcc	R/W	S16	0 = No DHW during UnOcc, 1 = DHW during UnOcc	1011
	WWSD During Occ	R/W	S16	40 to 100°F (5 to 38°C)	1012
	WWSD During UnOcc	R/W	S16	40 to 100°F (5 to 38°C)	1013
Monitor Mode Tank				MODBUS = MNTR and Tank Mode	
	Tank Setpoint	R/W	S16	50 to 190°F (10 to 88°C) For temperatures higher than 160°F (71°C) ensure application uses a boiler-rated unit.	1014
	Tank Differential	R/W	S16	2 to 10°F (1 to 24°C)	1015
	Tank During UnOcc	R/W	S16	0 = No heating during UnOcc, 1 = heating during UnOcc	1016
Monitor Mode Pool				MODBUS = MNTR and Pool Mode	
	Pool Setpoint	R/W	S16	50 to 104/106°F (10 to 40/41°C)	1017
	Pool Differential	R/W	S16	2 to 10°F (1 to 24°C)	1018
	Pool Supply Max	R/W	S16	110 to 120°F (44 to 49°C)	1019
	Pool During UnOcc	R/W	S16	0 = No heating during UnOcc, 1 = heating during UnOcc	1020
	Reserved				

Table AF. Modbus Monitor Modes

Register	Parameter	Read/Write	Format	Note	Register Address
Pump Control Mode Parameters				MODBUS = TEMP or RATE	
	System Pump	R/W	S16		1021
	DHW Pump	R/W	S16		1022
	Boiler Pump	R/W	S16	Only relevant when MODBUS = RATE	1023
	Reserved				
Temperature Control Mode Parameters				MODBUS = TEMP	
	Target temperature	R/W	S16	50 to PIM value	1024
	Auto Diff	R	S16	0 = off, 1 = on	132
	Manual Differential	R/W	S16	2 to 42°F (1 to 23.5°C) (only relevant when auto diff is off)	1025
	Reserved				
Rate Control Mode Parameters				MODBUS = RATE	
	Target Mod Rate	R/W	S16	0 - 100%	1026
		R/W	S16	50 to 140°F (10 to 60°C) (not available in initial release)	1027
	Reserved				

Table AG. Modbus Control Mode Parameters

Modbus Error Codes					
Code	Description	Code	Description	Code	Description
0	No Error	21	Extra Safety Input	41	Delta-T Max
1	EEPROM Fault	22	Flow Switch	42	HSI Proof
2	Outdoor Sensor (S4)	23	Air Pressure Switch	43	Low Voltage
3	Supply Sensor (S3)	24	Safety Option 1	44	Blower Speed
4	Plant Sensor IND Supply (S6)	25	Safety Option 2	45	Safety Input
5	Mix Sensor	26	Safety Option 3	46	Duplicate Master
6	DHW Sensor (S5)	27	LWCO (Jumper)	47	Device Error
7	Tank Sensor	28	Water Pressure (Jumper)	48	Device Lost
8	Pool Sensor	29	Air Pressure (Jumper)	49	Supply Sensor / Pool Max Error
10	No PIM1	30	Gas Pressure (Jumper)	50	MIX Lock Error
11	Dev Lost / No VRS 2 or No PIM 2	31	Boiler Outlet Sensor	51	PIM 2 Ignition Failure
12	Dev Lost / No VRS 3 or No PIM 3	32	Boiler Inlet Sensor	52	PIM 2 False Flame
13	Dev Lost / No VRS 4 or No PIM 4	33	Vent Sensor	53	PIM2 OEM ID Error
14	Condensate Switch	34	High Limit Sensor	54	PIM 2 Internal Failure
15	Vent Temperature	35	Ignition Failure	55	PIM 2 HSI Proof
16	Auto Hi-Limit	36	Vent Hi-Limit	56	PIM 2 Low Voltage
17	Low Water Cutoff Module	37	Boiler Hi-Limit	57	PIM 2 Blower Speed
18	Blocked Vent Switch	38	False Flame	59	Flow Read Error
19	Low Gas Pressure	39	OEM ID Card	60	Under-Flow Error
20	High Gas Pressure	40	Internal Fault	61	Flow Warning

Table AH. Modbus and VERSA Error Codes

Modbus Error Codes	
Code	Description
62	Device Lost, Cascade Follower # 5
63	Device Lost, Cascade Follower # 6
64	Device Lost, Cascade Follower # 7
65	Device Lost, Cascade Follower # 8
66	Auto Hi-Limit from PIM
67	Manual Hi-Limit from PIM
68	Blower Loss from Tach Signal
69	Flame Loss Warning

Table AH. Modbus and VERSA Error Codes (Continued)

17. QR CODES

VIEW THIS INSTALLATION MANUAL AND CORRESPONDING MANUALS ON YOUR SMART DEVICE.
THE QR CODES WILL TAKE YOU TO THE MOST CURRENT VERSION OF EACH MANUAL.
PREVIOUS VERSIONS OF MANUALS CAN BE FOUND IN THE DOCUMENT LIBRARY AT RAYPAK.COM.

P/N: 241493 VERSA IC CONTROL INSTALLATION MANUAL



P/N: 241630 VERSA IC QUICK START GUIDE



P/N: 241515 PROTONODE INSTALLATION MANUAL



NOTES
