

**FS/FD Series**

# AIR-COOLED FLUID COOLER



## Consider The Possibilities

- Cools most any non-corrosive fluid
- Closed-circuit cooling avoids contamination
- Cold weather economizer for interior cooling loads
- HVAC and computer room air conditioning
- Industrial cooling applications
  - Cutting fluids
  - Machinery cooling jackets
  - Electrical gear

## Standard Features:

- Vertical air discharge configuration
- Galvanized steel frame and casing
- Aluminum Fins / Copper tubes
- 6 pole 1140 RPM motors
- Heavy gauge Aluminum Fan blades with steel hub
- Fully baffled fan modules
- Weather tight control panel
- Epoxy Coated Fan guards

## Optional Features:

- Horizontal air discharge configuration
- Aluminum Casing (galvanized frame and legs)
- Coated or Copper fins
- 8 Pole 825 rpm motors
- Flip top hinged fan panels
- Removable side access panels
- Control panel mounting location
- Motor fusing
- Circuit breakers
- Fan control toggle switches
- Fused disconnect switch

# FS/FD SERIES

## Table of Contents

Nomenclature .....	2
Features and Options .....	3
Performance Range Tables — 1140 RPM Models .....	4
Performance Range Tables — 825 RPM Models .....	5
Fan and Motor Data .....	6
Sound Pressure Options .....	6
Electrical Control Options .....	7
Typical Wiring Diagrams — Single Phase .....	7
Typical Wiring Diagrams — Three Phase .....	8
Detail Photographs and Features .....	9
Weights and Volumes .....	10
Connection Sizes .....	10
Fan Motor Amps .....	10
Dimensional Drawings .....	10-11
Standard Specifications .....	Back Cover

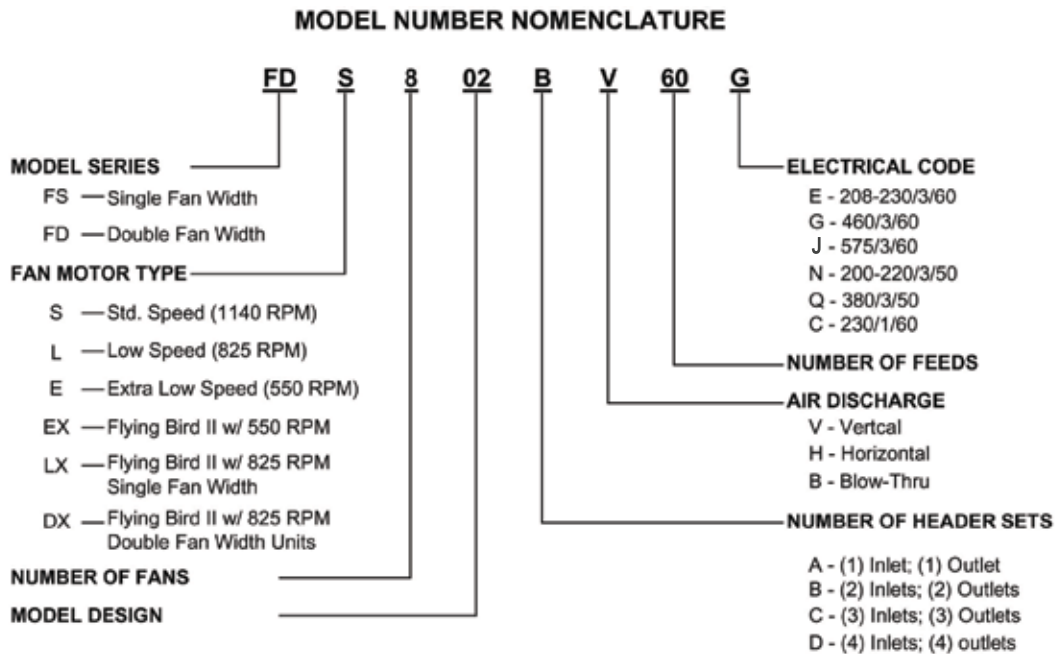

# FS/FD SERIES

## Standard and Optional Features

DESCRIPTION	Notes	UNIT MODEL	
		FS 101 A— 203 A	FS-204A— 603A FD-401B—1203B
General Construction and Configuration			
Vertical Air Discharge Configuration		Std	Std
Horizontal Air Discharge Configuration		Opt	Opt
Galvanized Steel Frame and Casing		Std	Std
Embossed Aluminum Casing (Galvanized Steel Frame and Legs)		Opt	Opt
Heavy Gauge Galvanized Steel Legs (Vert. Air Disch):		15" (Std)	Std
18" Leg Length			
30" or Custom Leg Length	A	N/A	Opt
Fluid Cooler Coil			
16 Gauge Galvanized Steel Casing and Aluminum Tube Sheets		Std	Std
Aluminum Fins Mechanically Expanded into Copper Tubes		Std	Std
Special Fin Materials: Up to .010" Thick Aluminum		Opt	Opt
Copper Fin Stock		Opt	Opt
Polyester-Coated Fin Stock		Opt	Opt
ElectroFin™ and Phenolic-Coated Coils		Opt	Opt
Fan Section			
6-Pole (1140 RPM), 1 -Phase (PSC) or 3-Phase Fan Motors:			
Open Type	E	Std	Std
Totally Enclosed	B	Opt	Opt
Fan Motor Mounting		Std	Std
FS-101A thru 203A — Steel Rail Rigid Mounting		Std	N/A
All Others — Welded heavy-gauge rod mounting frames		N/A	Std
Fan Blades - Heavy Gauge Aluminum Blades, Painted Steel Hubs		Std	Std
Fully Baffled Fan Modules		Std	Std
'Flip Top' Hinged Fan Panels - Easy Access for Coil Cleaning and Fan/Motor Service		N/A	Opt
Control Panel			
Weather-Tight Galvanized Steel Enclosure with All Motor Leads Pulled	C	Std	Std
Mounting Location: Header End		Std	Std
Temperature Fan Cycling - Individual- or Paired-Fan Contactors (Must specify)		Opt	Opt
Custom Fan Cycling Wiring and Logic		Opt	Opt
Motor Fusing - Individually or in Pairs		Opt	Opt
Circuit Breakers	B	Opt	Opt
Fan Control Circuit Toggle Switches		Opt	Opt
Control Transformer	B	Opt	Opt
Fused Disconnect Switch (Mounted)	B	Opt	Opt
Shipping			
Vertical Discharge Models FS-101A thru 203A	D	Std	—
Vertical Discharge Models All Others — Legs are collapsed for shipping and must be re-extended during installation		—	Std
Horizontal Discharge Models			
Legs Disassembled - Unit is Cartoned or Crated		See Note D	See Note A

### Notes

A. Contact factory for information

B. Not UL Listed

C. Units which are five and six fans long are furnished with motor leads wired to 3-Phase Terminal Blocks.

D. Legs disassembled; units shipped in carton or crate. Models FS-101A thru 203A can be either horizontal or vertical depending on method of leg assembly.

E. 1-Phase PSC Motors available on models FS-101A thru 207A only.

# FS/FD SERIES

**Table 1: Range of Performance † - 1140 RPM—6-Pole Fans**

## Single Fan-Width Units

Model No.	Minimum			Maximum		
	MBH	ΔT	GPM	MBH	ΔT	GPM

### FSS

101A	26.8	6.0	10	30.4	3.2	20
102A	42.0	9.2	10	48.0	5.2	20
103A	63.6	14.0	10	84.0	6.4	30
104A	80.0	17.6	10	106.8	4.8	50
201A	100.0	22.4	10	172.4	5.6	70
202A	122.4	27.2	10	213.6	4.8	100
203A	169.2	18.8	20	233.2	3.6	140
204A	182.4	20.4	20	272.8	6.0	100
205A	196.4	22.0	20	306.8	6.8	100
206A	224.4	25.2	20	368.0	5.2	160
207A	238.8	26.8	20	407.2	5.6	160

## Single Fan-Width Units

Model No.	Minimum			Maximum		
	MBH	ΔT	GPM	MBH	ΔT	GPM

### FSS

208A	261.2	29.2	20	507.6	7.2	160
209A	337.6	25.2	30	545.6	7.6	160
210A	357.2	26.4	30	590.4	6.0	220
211A	395.6	29.2	30	668.9	5.3	280
301A	419.6	31.2	30	826.0	7.2	260
302A	513.6	28.8	40	887.2	5.6	340
303A	535.6	30.0	40	962.8	5.2	400
401A	556.0	30.8	40	1044.4	10.4	220
402A	588.0	32.8	40	1142.4	8.4	300
403A	607.6	34.0	40	1258.4	7.2	380
404A	620.8	34.8	40	1306.4	7.6	380
501A	636.8	35.6	40	1382.8	10.8	280
502A	652.8	36.4	40	1538.0	9.6	360
503A	795.2	35.6	50	1598.4	10.0	360
601A	893.2	33.2	60	1598.0	13.6	260
602A	1030.4	32.8	70	1780.4	12.4	320
603A	1181.2	29.2	90	1852.0	12.8	320

## Double Fan-Width Units

Model No.	Minimum			Maximum		
	MBH	ΔT	GPM	MBH	ΔT	GPM

### FDS

401 B	470.0	34.8	30	1048.8	10.4	220
402B	590.0	32.8	40	1145.2	8.4	300
403B	623.9	34.8	40	1289.2	5.2	550
404B	637.2	35.6	40	1336.0	5.4	550
601 B	735.2	32.8	50	1643.2	7.2	500
602B	782.0	34.8	50	1730.4	6.8	550
603B	924.4	34.4	60	1847.2	9.2	450
801 B	1010.4	32.0	70	2097.6	10.4	450
802B	1066.4	34.0	70	2256.6	9.2	550
803B	1122.4	35.6	70	2413.6	9.6	550
804B	1142.4	36.4	70	2508.0	10.0	550
1001B	1273.2	35.6	80	2756.8	11.2	550
1002B	1436.0	35.6	90	2950.4	12.0	550
1003B	1590.4	35.6	100	3068.8	12.4	550
1201B	1786.4	33.2	120	3168.8	14.0	500
1202B	1845.2	34.4	120	3460.5	14.0	550
1203B	2113.3	33.7	140	3601.6	14.6	550

† 100° F. Entering air temperature; 140° F. Entering fluid temperature; 40% Ethylene Glycol  
Performance ranges are given to suggest approximate capacity of units. Contact factory for  
computer-rated units before final selection.

Please Specify: Capacity or leaving fluid temperature

Fluid type & concentration

Entering fluid temperature

Flow rate in GPM

Entering air temperature

**Table 1: Range of Performance † - 825 RPM—8-Pole Fans****Single Fan-Width Units**

Model No.	Minimum			Maximum		
	MBH	ΔT	GPM	MBH	ΔT	GPM

**FSL**

101A	22.6	5.0	10	25.1	2.8	20
102A	34.4	7.6	10	38.3	4.2	20
103A	50.0	11.1	10	61.5	4.5	30
104A	64.2	14.3	10	79.4	3.5	50
201A	82.8	18.4	10	125.2	4.0	70
202A	104.8	23.2	10	158.8	3.5	100
203A	138.3	15.4	20	174.6	2.8	140
204A	164.8	18.3	20	233.5	5.2	100
205A	177.2	19.7	20	260.2	5.8	100
206A	205.7	22.9	20	310.6	4.3	160
207A	219.3	24.4	20	340.0	4.7	160

**Single Fan-Width Units**

Model No.	Minimum			Maximum		
	MBH	ΔT	GPM	MBH	ΔT	GPM

**FSL**

208A	243.6	27.1	20	426.2	5.9	160
209A	308.3	22.9	30	456.6	6.3	160
210A	325.3	24.1	30	487.1	4.9	220
211A	366.4	27.2	30	556.1	4.4	280
301A	393.3	29.2	30	690.0	5.9	260
302A	471.7	26.3	40	731.4	4.8	340
303A	497.4	27.7	40	796.9	4.4	400
401A	520.8	29.0	40	882.8	8.9	220
402A	551.7	30.8	40	950.1	7.0	300
403A	576.4	32.1	40	1047.1	6.1	380
404A	593.0	33.1	40	1093.0	6.4	380
501A	607.9	33.9	40	1159.1	9.2	280
502A	629.4	35.1	40	1287.4	7.9	360
503A	760.5	33.9	50	1345.3	8.3	360
601A	838.1	31.1	60	1351.9	11.6	260
602A	965.6	30.8	70	1504.1	10.4	320
603A	1094.7	27.1	90	1573.8	10.9	320

**Double Fan-Width Units**

Model No.	Minimum			Maximum		
	MBH	ΔT	GPM	MBH	ΔT	GPM

**FDL**

401B	449.4	33.4	30	886.2	8.9	220
402B	553.7	30.9	40	952.1	7.0	300
403B	592.3	33.0	40	1065.9	4.3	550
404B	609.4	34.0	40	1111.0	4.5	550
601B	697.3	31.1	50	1374.1	9.1	500
602B	744.3	33.2	50	1435.0	5.8	550
603B	877.4	32.6	60	1561.2	6.9	450
801B	955.4	30.4	70	1771.5	8.7	450
802B	1010.7	32.2	70	1881.6	7.6	550
803B	1075.7	34.3	70	2028.9	8.2	550
804B	1102.4	35.1	70	2120.7	8.6	550
1001B	1215.9	33.9	80	2312.7	9.3	550
1002B	1374.0	34.1	90	2494.9	10.1	550
1003B	1520.9	33.9	100	2610.0	10.5	550
1201B	1676.2	31.1	120	2686.1	11.9	500
1202B	1750.8	32.5	120	2943.9	11.9	450
1203B	1996.1	31.8	140	3081.7	12.5	450

† 100° F. Entering air temperature; 140° F. Entering fluid temperature; 40% Ethylene Glycol  
Performance ranges are given to suggest approximate capacity of units. Contact factory for  
computer-rated units before final selection.

Please Specify: Capacity or leaving fluid temperature

Fluid type & concentration

Entering fluid temperature

Flow rate in GPM

Entering air temperature

# FS/FD SERIES

**Table 2: Fan and Motor Data**

Fan Data								Motor Data †							
Unit Size	Qty	Dia (In)	Total CFM		Sound Levels*		Nom. HP		MCA— 1140 RPM Models Δ			MCA— 825 RPM Models Δ			
			1140 RPM	825 RPM	1140 RPM	825 RPM	1140 RPM	825 RPM	208-230 3ø	460 3ø	575 3ø	208-230 3ø	460 3ø	575 3ø	
<b>SINGLE FAN-WIDTH MODELS</b>															
<b>FSS</b>	<b>FSL</b>														
101A	101A	1	18	3000	2540	—	—	1/2	1/4	Minimum Circuit Ampacity: 15.0 a. All Listed Voltages — 1ø and 3ø					
102A	102A	1	18	2650	2040	—	—								
103A	103A	1	22	4250	2850	—	—								
104A	104A	1	22	3850	5740	—	—								
201A	201A	2	22	8550	5700	—	—	1	1						
202A	202A	2		7700	5480	—	—								
203A	203A	2		7000	5110	—	—								
204A	204A	2	26	15400	11600	—	—	1	1						
205A	205A	2		15250	11400	—	—								
206A	206A	2		15000	11500	—	—								
207A	207A	2		14850	11300	—	—								
208A	208A	2		30	21500	16000	66.0			61.0	1 1/2	1	15.0	15.0	15.0
209A	209A	2	21000		15700	66.0	61.0	15.0	15.0	15.0			15.0	15.0	—
210A	210A	2	20500		15300	66.0	61.0	15.0	15.0	15.0			15.0	15.0	—
211A	211A	2	20000		14900	66.0	61.0	15.0	15.0	15.0			15.0	15.0	—
301A	301A	3	32000		23900	67.0	62.5	21.1	15.0	15.0			17.2	15.0	—
302A	302A	3	31500		23500	67.0	62.5	21.1	15.0	15.0			17.2	15.0	—
303A	303A	3	31000		23100	67.0	62.5	21.1	15.0	15.0			17.2	15.0	—
401A	401A	4	42000		31300	68.0	63.0	27.6	15.0	15.0			22.5	15.0	—
402A	402A	4	41000		30600	68.0	63.0	27.6	15.0	15.0			22.5	15.0	—
403A	403A	4	40500		30200	68.0	63.0	27.6	15.0	15.0			22.5	15.0	—
404A	404A	4	40000		29700	68.0	63.0	27.6	15.0	15.0			22.5	15.0	—
501A	501A	5	51250		38200	68.5	63.5	34.1	17.3	15.0			27.8	15.0	—
502A	502A	5	50625	37800	68.5	63.5	34.1	17.3	15.0	27.8	15.0	—			
503A	503A	5	50000	37300	68.5	63.5	34.1	17.3	15.0	27.8	15.0	—			
601A	601A	6	61500	45900	69.0	64.0	40.6	20.6	15.0	33.1	16.6	—			
602A	602A	6	61750	45300	69.0	64.0	40.6	20.6	15.0	33.1	16.6	—			
603A	603A	6	60000	44800	69.0	64.0	40.6	20.6	15.0	33.1	16.6	—			
<b>DOUBLE FAN-WIDTH MODELS</b>															
401B	401B	4	30	42000	31300	68.0	63.0	1 1/2	1	27.6	15.0	15.0	22.5	15.0	—
402B	402B	4		41000	30600	68.0	63.0			27.6	15.0	15.0	22.5	15.0	—
403B	403B	4		40500	30200	68.0	63.0			27.6	15.0	15.0	22.5	15.0	—
404B	404B	4		40000	29800	68.0	63.0			27.6	15.0	15.0	22.5	15.0	—
601B	601B	6		64000	47700	69.0	64.0			40.6	20.6	15.0	33.1	16.6	—
602B	602B	6		63000	47000	69.0	64.0			40.6	20.6	15.0	33.1	16.6	—
603B	603B	6		62000	46200	69.0	64.0			40.6	20.6	15.0	33.1	16.6	—
801B	801B	8		84000	62600	70.0	64.5			53.6	27.2	19.8	43.7	21.9	—
802B	802B	8		82000	61100	70.0	64.5			53.6	27.2	19.8	43.7	21.9	—
803B	803B	8		81000	60400	70.0	64.5			53.6	27.2	19.8	43.7	21.9	—
804B	804B	8		80000	59700	70.0	64.5			53.6	27.2	19.8	43.7	21.9	—
1001B	1001B	10		102500	76400	71.0	66.0			66.6	33.8	24.6	54.3	27.2	—
1002B	1002B	10	101250	75600	71.0	66.0	66.6	33.8	24.6	54.3	27.2	—			
1003B	1003B	10	100000	74600	71.0	66.0	66.6	33.8	24.6	54.3	27.2	—			
1201B	1201B	12	123000	91800	71.5	67.0	79.6	40.4	29.4	64.9	32.5	—			
1202B	1202B	12	121500	90600	71.5	67.0	79.6	40.4	29.4	64.9	32.5	—			
1203B	1203B	12	120000	89600	71.5	67.0	79.6	40.4	29.4	64.9	32.5	—			

\* Sound pressure ratings in dBA 30 feet from unit

† Refer to Page 10 for individual fan motor amp ratings.  
Minimum Circuit Ampacity

### Fan Cycling—Multi-Fan Units

The Fan Cycling Control system allows fans to be cycled off or on in sequence.

The cycling of fluid cooler fan(s) provides an automatic means of controlling leaving fluid temperature at low ambient air temperatures. It also results in substantial fan motor power savings in lower ambients. Ambient temperature or optional fluid temperature sensing thermostats are used.

Fans are cycled individually on Model FS (single fan-width units); or in pairs on Model FD (double fan-width units). The fan, or fans, nearest the header end of the unit run continuously.

The fan cycling control package consists of a weatherproof enclosure, fan contactors and ambient thermostat(s). The enclosure is factory mounted and completely factory wired. Power must be supplied from a fused disconnect switch to the power circuit terminal block; control circuit power must be supplied to the control terminal block.

### Fan Cycling Arrangement

Single Fan Width		Double Fan Width	
Fan Config.	Fans Cycled Per Control	Fan Config.	Fans Cycled Per Control
1x2	1 pair	2x2	1 pair
1x3	1 pair, 1 pair	2x3	1 pair, 1 pair
1x4	1 pair, 1 pair, 1 pair,	2x4	1 pair, 1 pair, 1 pair,
1x5	2 pairs, 1 pair, 1 pair,	2x5	2 pairs, 1 pair, 1 pair,
1x6	2 pairs, 2 pairs, 1 pair,	2x6	2 pairs, 2 pairs, 1 pair,

### Bypass Fluid Temperature Control

A factory mounted three-way mixing valve with aquastat is available to control leaving fluid temperature.

### Fan Speed Control Options

Available only with Fan Cycling Control Option on Multi-Fan Units.

Designed to enhance the performance of the Fan Cycling Control Option by reducing the RPM and air volume of the lead (header end) fanmotor(s) after all other (lag) fans have cycled off. The lead fan(s) must run continuously, even in the lowest ambient temperature. By reducing their CFM, desired liquid temperature can be maintained at lower ambients.

### Temperature Controlled Fan Speed

Includes Hoffman Speed Controller and single phase fan motor. Double fan-width units require one controller for the two lead fan motors. All components are factory mounted. Controller sensing element is mounted on the return header. Controller decreases fan motor RPM as liquid temperature decreases.

### Wiring Options

Standard units are furnished with the motor leads terminated in a single weatherproof enclosure located opposite the header end of the unit. A terminal block is provided on six-fan units and larger.

When the fan cycling control option is ordered, the units are furnished with contactors, power circuit terminal block (except on single fan units), fan cycling controls, a control terminal block and motor fusing, if specified. These components are installed in a weatherproof enclosure, factory mounted and completely wired.

See Figures 3, 4 and 5 for wiring details.

Figure 3: Single Phase Units

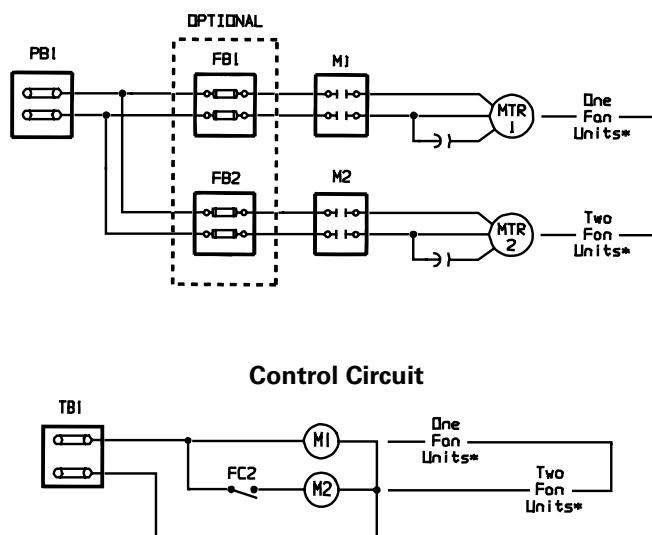

\*Refer to Page 11 for Model Number vs. Fan Configuration

### Legend

- FB1 - FB3 ..... Fuse Blocks
- FC2 - FC3 ..... Fan Cycling Controls
- M1 - M3 ..... Fan Motor Contactors
- MTR1 - MTR3 ..... Fan Motors
- TB1 ..... Control Terminal Block
- PB1 ..... Power Terminal Block

### Notes

1. Motor 1 is always located at the header end of the unit.
2. PB1 is not furnished on single fan units.
3. Field control wiring connections are made to terminal block TB1.
4. Contactor holding coils can be furnished in most voltages, including 24, 115, 208-230 or 460 volts.
5. Fan cycling controls FC2 and FC3 can be furnished either as ambient temperature controls or pressure controls.

# FS/FD SERIES

## TYPICAL WIRING — THREE PHASE UNITS

Figure 4: Single Fan-Width Units

Power Wiring

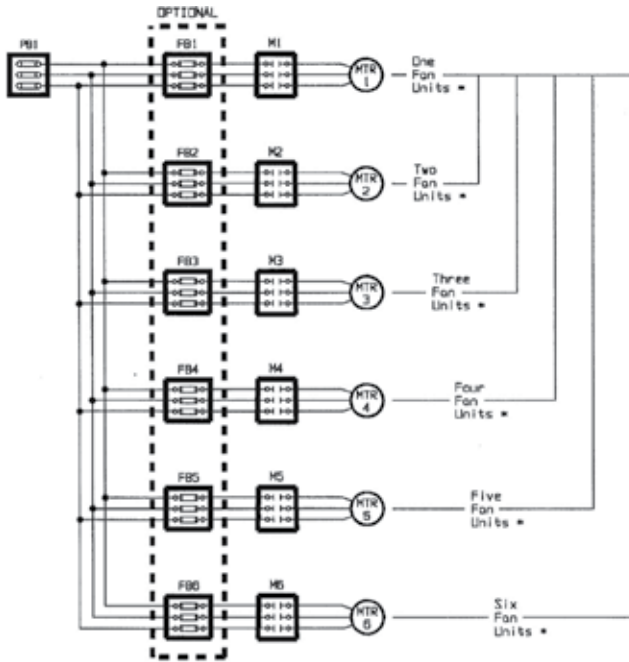

Control Wiring

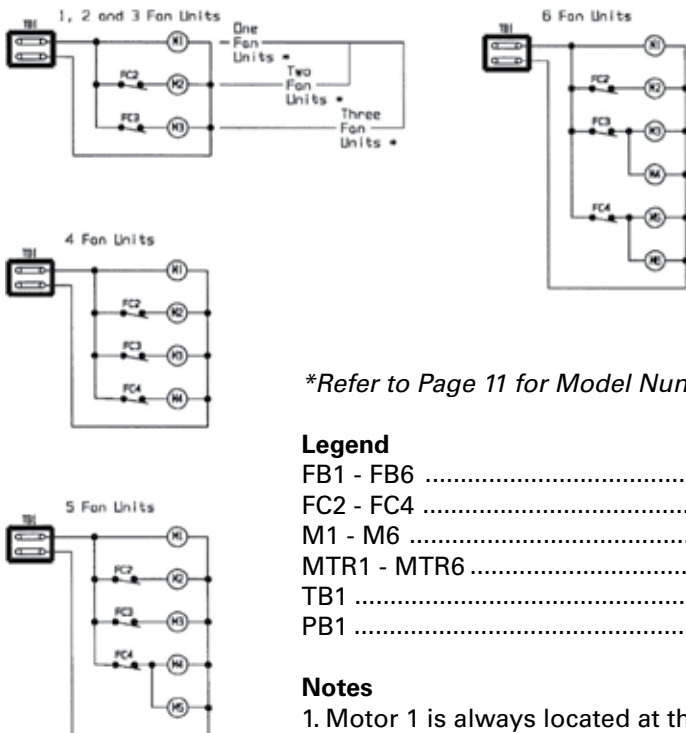
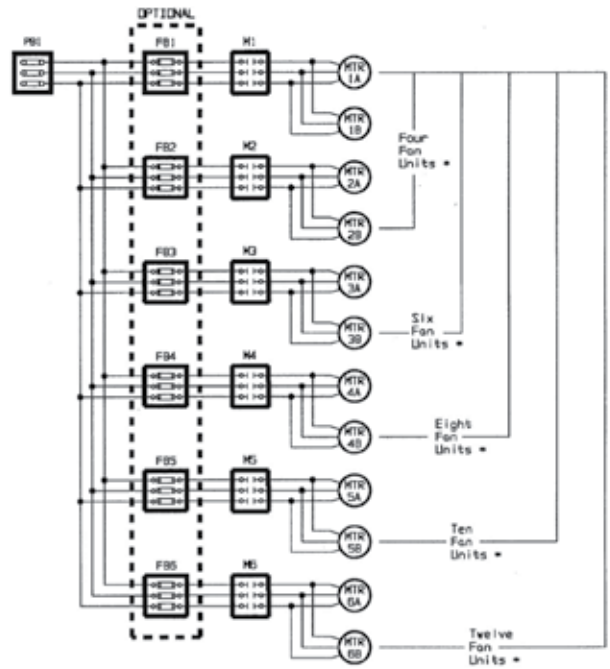
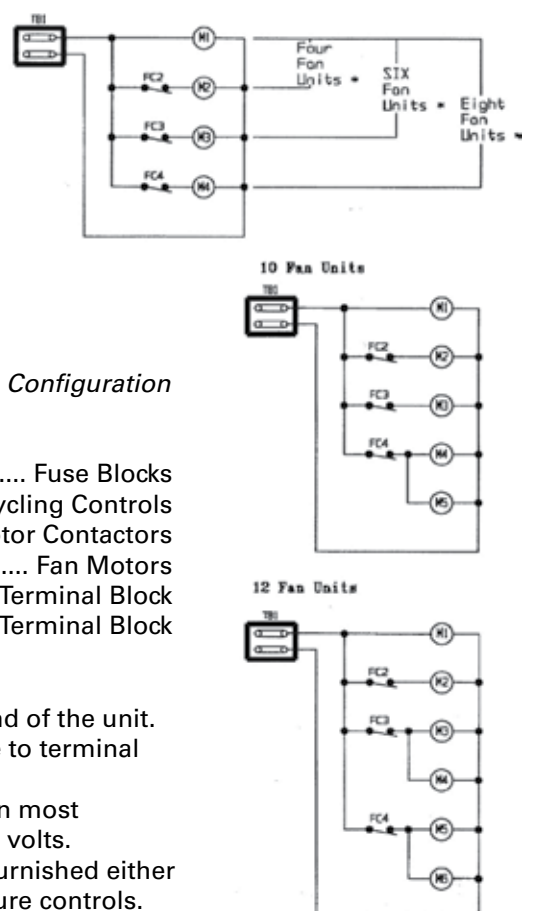

Figure 5: Double Fan-Width Units

Power Wiring



Control Wiring



\*Refer to Page 11 for Model Number vs. Fan Configuration

**Legend**

- FB1 - FB6 ..... Fuse Blocks
- FC2 - FC4 ..... Fan Cycling Controls
- M1 - M6 ..... Fan Motor Contactors
- MTR1 - MTR6 ..... Fan Motors
- TB1 ..... Control Terminal Block
- PB1 ..... Power Terminal Block

**Notes**

1. Motor 1 is always located at the header end of the unit.
2. Field control wiring connections are made to terminal block TB1.
3. Contactor holding coils can be furnished in most voltages, including 24, 115, 208-230 or 460 volts.
4. Fan cycling controls FC2 and FC3 can be furnished either as ambient temperature controls or pressure controls.



# FS/FD SERIES

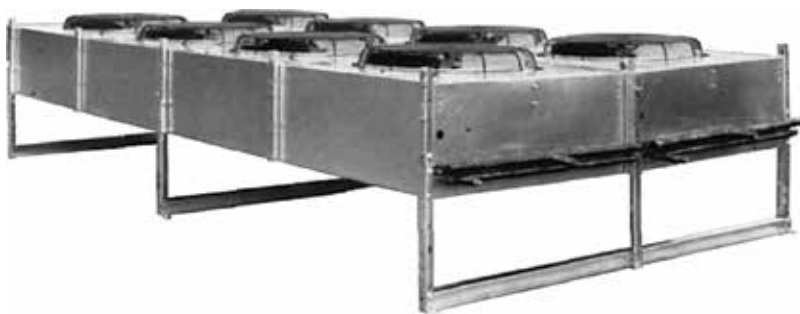

## STANDARD FEATURES

- Direct Drive Fans
- 1140 RPM—Model FSS/FDS
- 825 RPM—Model FSL/FDL
- Horizontal Air Discharge available
- Single and Double Fan-Width models
- 45 Model Sizes
- Shipped in operating position (Vertical Discharge)
- Hoisting Eyes for easy rigging Galvanized Steel
- Casing and Frame

## TYPICAL FAN CYCLING CONTROL PANEL

- Standard Location — Header End. (Side or Opposite-to-Header-End Mount available)
- Weather-Tight Enclosure
- Options: Temperature Controls
  - Variable Speed Control (Lead Fans) Custom
  - Wiring and Logic Motor Fusing or Circuit
  - Breakers Motor Contactors Control

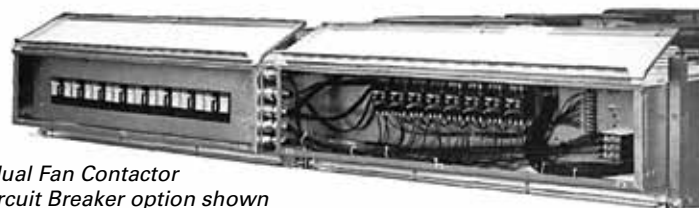

*Individual Fan Contactor and Circuit Breaker option shown*

## TRANSFORMERS

- A. Hoisting Eye
- B. Return Bend Cover (UL required)
- C. Hinged Control Panel Cover
- D. 10 Ga. Legs and Cross-supports

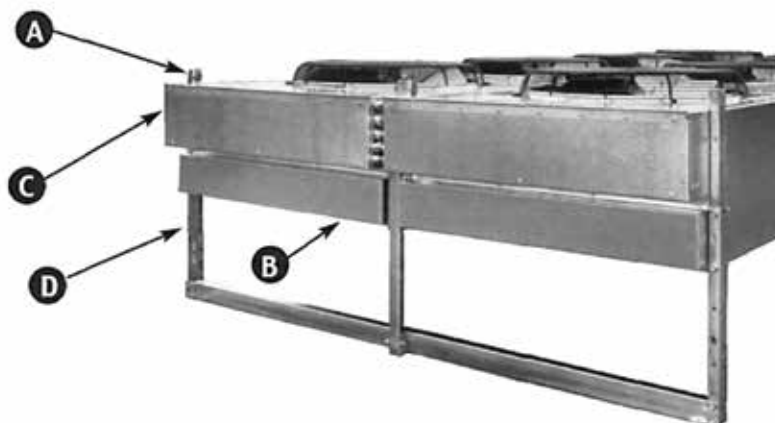

## 'FLIP-TOP' VENTURI PANELS

- Makes coil cleaning quick and thorough
- Dirt can be flushed back through the coil to avoid coil plugging.
- Permits Easy Fan and Motor Service

## Small Frame Models

### DUAL FAN UNITS

- 8 thru 12Tons — Standard Fan-Speed Models
- 6 thru 9Tons — Low Fan-Speed Models

### SINGLE FAN UNITS

- 1 thru 5Tons — Standard Fan-Speed Models
- 6 thru 9Tons — Low Fan-Speed Models

- A. Universal Mounting Legs, Horizontal or Vertical Heavy Gauge, Galvanized Steel Casing & Legs
- B. Header Guard (UL Required)

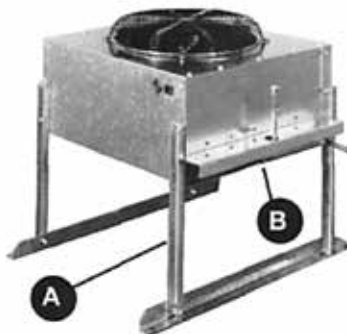

# FS/FD SERIES

## Dimensional & Physical Data

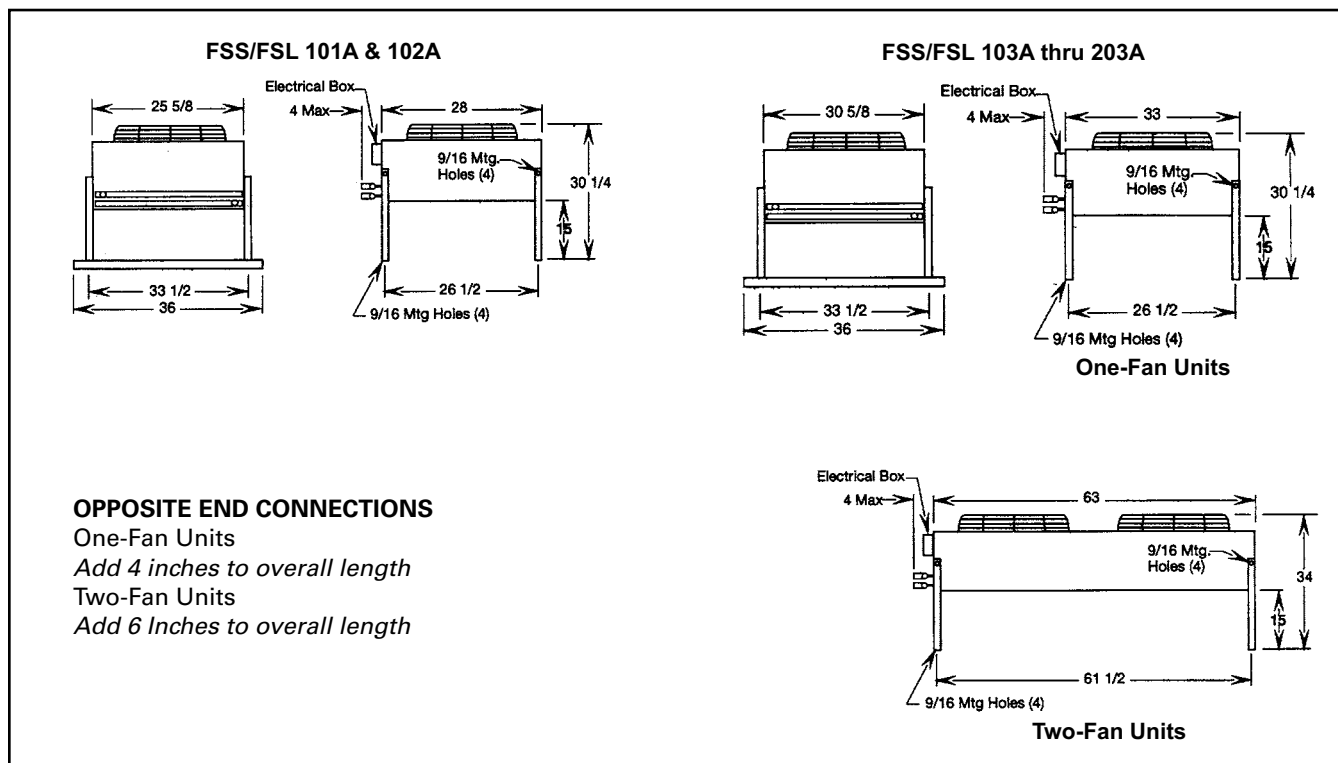

### Unit Volume & Weights

Model Size	Fluid Data		Unit Weight Dry
	Volume Gal.	Weight Lbs.	

Model Size	Fluid Data		Unit Weight Dry
	Volume Gal.	Weight Lbs.	

#### Single Fan-Width Units FSS/FSL

101A	.44	3.7	109
102A	.89	7.4	121
103A	1.26	10.5	144
104A	1.90	15.8	160
201A	2.44	20.3	234
202A	3.66	30.5	259
203A	4.88	40.6	283
204A	4.89	40.7	410
205A	4.89	40.7	418
206A	7.33	61.0	436
207A	7.33	61.0	455
208A	7.33	61.0	495
209A	7.33	61.0	520
210A	9.77	81.4	550
211A	12.21	101.7	600
301A	10.85	90.4	800
302A	14.47	120.6	900
303A	18.09	150.7	1000
401A	14.38	119.8	1050
402A	19.17	159.7	1100
403A	23.97	199.7	1150
404A	23.97	199.7	1200
501A	23.88	198.9	1370
502A	29.85	248.6	1430
503A	29.85	248.6	1490
601A	28.58	238.1	1690
602A	35.72	297.6	1750
603A	35.72	297.6	1830

#### Double Fan-Width Units FDS/FDL

401B	14.66	122.1	1080
402B	19.54	162.8	1140
403B	24.43	203.5	1190
404B	24.43	203.5	1240
601B	21.71	180.8	1640
602B	28.95	241.1	1840
603B	36.18	301.4	2050
801B	28.76	239.6	2150
802B	38.35	319.4	2250
803B	47.94	399.3	2350
804B	47.94	399.3	2460
1001B	47.75	397.8	2800
1002B	59.69	497.2	2950
1003B	59.69	497.2	3075
1201B	57.16	476.1	3400
1202B	71.44	595.1	3620
1203B	71.44	595.1	3750

### Fan Motor Amps

#### 1140 RPM

1/2 HP	208-230/1/60	2.5 a.
	208-230/3/60	2.0 a.
	460/3/60	1.0 a.
	575/1/60	1.0 a.
1 HP	208-230/1/60	4.9 a.
	208-230/3/60	4.0 a.
	460/3/60	2.0 a.
1 1/2 HP	208-230/1/60	N/A
	208-230/3/60	6.5 a.
	460/3/60	3.3 a.
	575/3/60	2.4 a.

#### 825 RPM

1/4 HP	208-230/1/60	1.4 a.
	208-230/3/60	1.1 a.
	460/3/60	0.6 a.
	575 Volt.	N/A
1 HP	208-230/1/60	N/A
	208-230/3/60	6.6 a.
	460/3/60	3.4 a.
	575 Volt.	N/A

### Connection Sizes †

GPM Range	Inlet & Outlet	
	Qty.	Size
10-20	1	1 1/4
20-40	1	1 1/2
40-70	1	2
70-100	1	2 1/2
100-150	1	3
150-200	2	2 1/2
200-300	2	3
300-450	3	3
450-550	4	3

† All connections are MPT

# FS/FD SERIES

## Fan Configuration

FSS/FSL Single Fan-Width			
Unit Size	Fan Config	Unit Size	Fan Config
101A	1 x 1	301A	1 x 3
102A		302A	
103A		303A	
104A		401A	
201A	1 x 2	402A	1 x 4
202A		403A	
203A		404A	
204A		501A	
205A	1 x 2	502A	1 x 5
206A		503A	
207A		601A	
208A		602A	
209A	1 x 2	603A	1 x 6
210A			
211A			

FDS/FDL Double Fan-Width	
Unit Size	Fan Config
401B	2x2
402B	
403B	
404B	
601B	2x3
602B	
603B	
801B	2x4
802B	
803B	
804B	
1001B	2x5
1002B	
1003B	
1201B	2x6
1202B	
1203B	

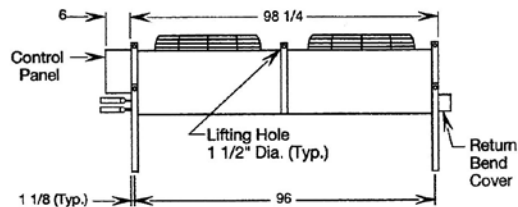

**END VIEW: Double Fan-Width Models**

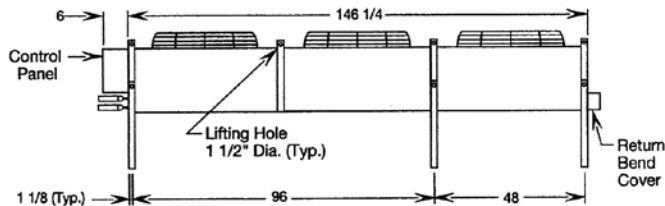
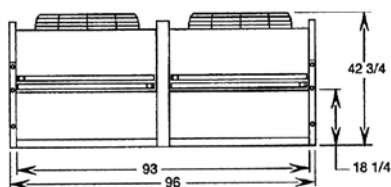

**END VIEW: Single Fan-Width Models**

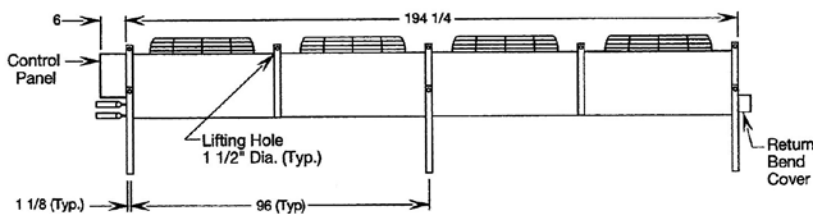
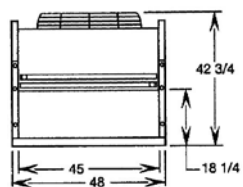

**NOTES**

Mounting legs are retracted for shipping purposes and must be lowered into position for unit installation.

Control panel can be mounted at opposite end if required.

Units are available for horizontal air discharge—contact factory for details.

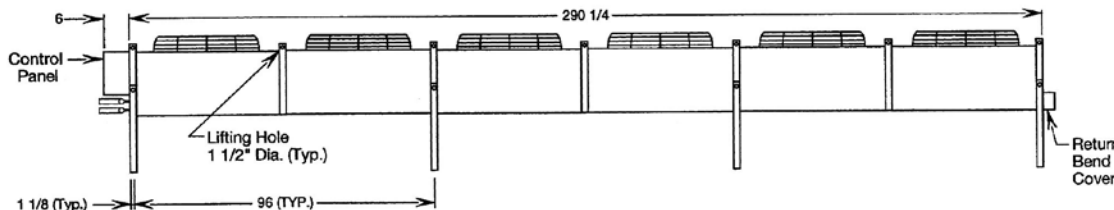
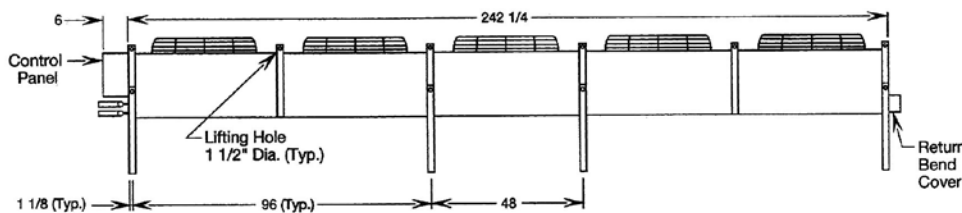

# FS/FD SERIES

## Specifications - Air Defrost Models

### General

Units shall be furnished as per the following specifications - Russell Model FS and FD air-cooled fluid coolers, arranged for vertical airflow (horizontal optional). All units to be UL & CUL and MEA-Listed.

### Unit Cabinets

Cabinets shall be constructed of heavy-gauge, corrosion resistant galvanized steel for maximum casing rigidity. (Optional heavy-gauge embossed aluminum shall be offered for extra corrosion resistance.)

All multiple fan units shall be divided by full width baffles to separate individual fan sections, prevent air bypass and provide additional casing reinforcement.

All end panels, center supports and partitions shall have collared tube holes for increased tube life.

Unit sizes FSS-204A and larger shall be provided with lifting eyes for rigging.

Unit sizes FSS-101A through FSS-203A shall have 12 gauge galvanized steel mounting legs and rails. Legs shall be shipped with the unit for field assembly. Headers are arranged for either horizontal or vertical airflow.

Unit sizes FSS-204A and larger shall have 10 gauge galvanized steel legs.

Unit sizes FSS-204A and larger can be arranged for vertical or horizontal airflow. Airflow must be specified for the header to have the correct connection location.

### Fluid Coil

Coils shall be constructed of 1/2 inch O.D. seamless copper tubing on a staggered pattern. Tubes shall be mechanically expanded into continuous full-collared plate-type aluminum (or optional copper) fins for permanent metal-to-metal contact. Headers shall be supplied with vents and drains. All coils shall be factory pressure and leak tested at 400 PSI.

### Fans

All fans shall be aluminum propeller blade type with painted steel hubs. Fans shall be dynamically balanced and factory tested before shipping to ensure quiet operation. Fans shall have dual square head set screws spaced 90 degrees apart which seat onto one flat and one keyway on the motor shafts. Fan diameters shall not exceed 30 inches.

### Fan Guards

Fan guards shall be heavy-gauge, close-meshed steel wire with vinyl coating for maximum rigidity, long life and attractive appearance.

### Fan Motors

Fan motors shall be heavy duty PSC or three phase open drip-proof type with permanently lubricated ball bearings and built-in overload protection.

All motors shall be factory wired with leads terminating in a weather-tight enclosure located opposite the header end of the unit. Leads on units having five or more fans shall terminate at a power block.

