



SUBMITTAL COVER SHEET

PROJECT NAME _____

LOCATION _____

ARCHITECT _____

ENGINEER _____

CONTRACTOR _____

SUBMITTED BY _____ DATE _____

UNIT SUMMARY

Quantity						
Unit Designation						
Model No.						
Total Cooling						
Sensible Cooling						
Air Ent. Evaporator						
Air Lvg. Evaporator						
Heating Input						
Heating Output						
CFM/ESP						
EER/SEER						
Electrical						
Minimum Ampacity						
Min.-Max. Breaker						
Net Unit Weight						
Accessory						
Catalog Form Number						

ACCESSORIES:

NOTES:

SUBMITTAL SHEET FOR PACKAGE GAS/ELECTRIC UNITS: RKNL-B WITH CAPACITIES FROM 6-12.5 TONS [21.1-44.0 kW]

JOB NAME _____
 CONTRACTOR _____
 ENGINEER _____
 LOCATION _____
 ORDER NO. _____
 SUBMITTED FOR APPROVAL RECORD
 SUBMITTED BY _____
 DATE _____
 UNIT DESIGNATION _____
 MODEL NO. _____

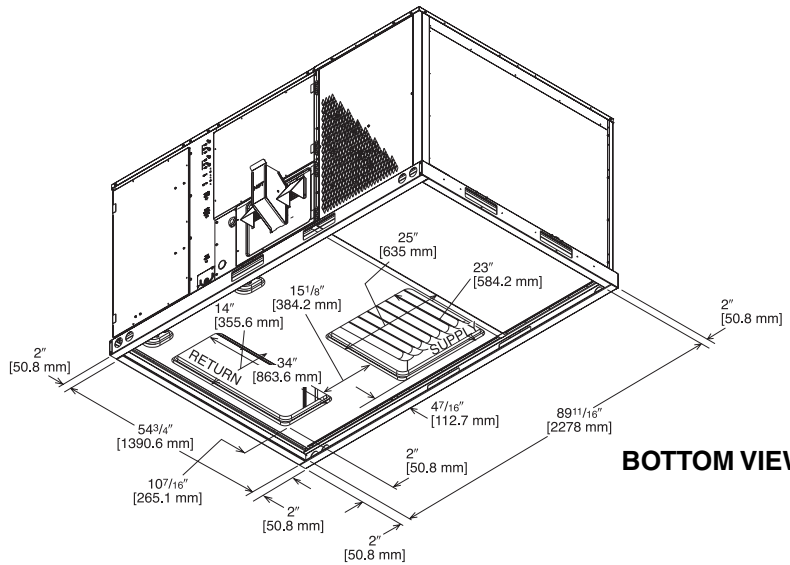

UNIT DATA

COOLING PERFORMANCE

TOTAL CAPACITY* MBH
 SENSIBLE CAPACITY* MBH
 EFFICIENCY (at ARI) EER
 PART LOAD EFFICIENCY IPLV
 AMBIENT DB TEMP °F
 ENTERING DB TEMP °F
 ENTERING WB TEMP °F
 LEAVING DB TEMP °F
 LEAVING WB TEMP °F
 TOTAL POWER INPUT kW
 ELEVATION FT
 SOUND POWER DBELS

HEATING PERFORMANCE

GAS HEAT INPUT BTU
 GAS HEAT OUTPUT BTU
 STEADY STATE EFFICIENCY MBH

SUPPLY AIR BLOWER PERFORMANCE

SUPPLY AIR CFM [L/s]
 OUTSIDE AIR CFM [L/s]
 EXTERNAL STATIC PRESSURE IWG
 DUCT CONNECTION LOCATION
 BLOWER SPEED RPM
 MOTOR RATING HP [W]
 BRAKE HORSEPOWER BHP
 POWER INPUT REQUIREMENT kW

ELECTRICAL DATA

POWER SUPPLY Hz
 MINIMUM CIRCUIT AMPACITY AMPS
 MAXIMUM OVERCURRENT DEVICE
 FUSE SIZE AMPS
 HACR CIRCUIT BREAKER AMPS

DIMENSIONS & WEIGHT

HEIGHT _____ IN WIDTH _____ IN DEPTH _____ IN
 TOTAL WEIGHT LBS [kg]
 (including factory options)

CLEARANCES

FRONT	48" [1219 mm]	BACK	18" [457 mm]
BOTTOM	0"	TOP	60" [1524 mm]
LEFT SIDE	18" [457 mm]		36" [914 mm]
RIGHT SIDE (condenser end)			18" [457 mm]

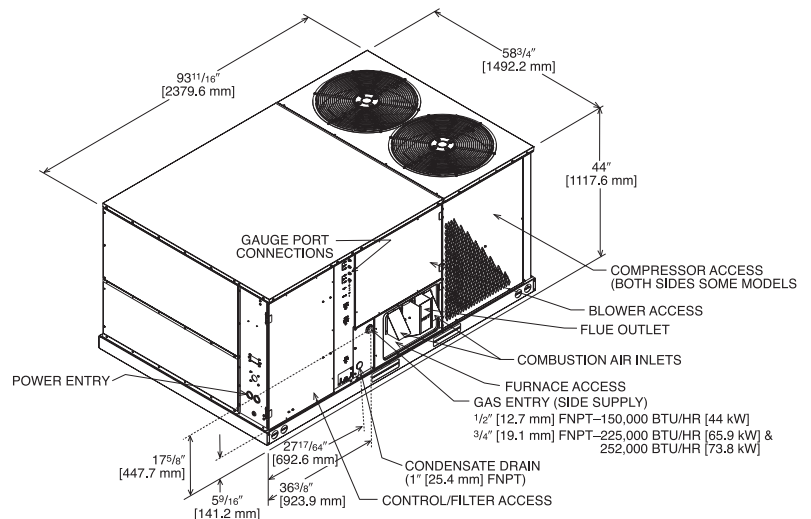

ROOFCURB INSTALLATION

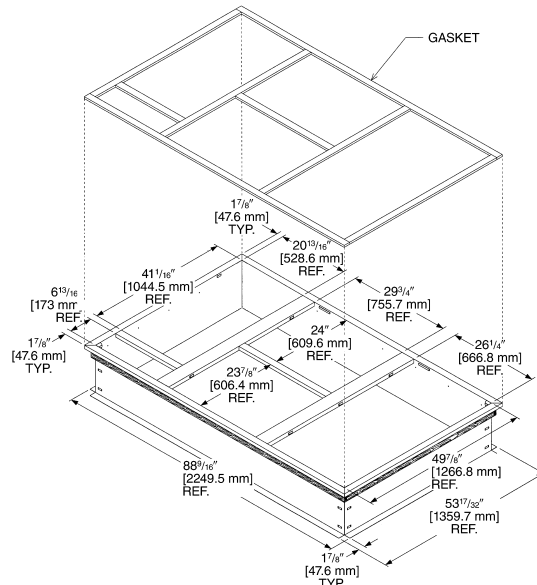

Roofcurb Includes Insulation Panels

[] Designates Metric Conversions

FEATURES FOR PACKAGE GAS/ELECTRIC UNITS 6 THRU 12.5 NOMINAL TONS [21.1 THRU 44.0 kW]

Gas Heat

- Two-Stage Gas Valve (50/100%) for Superior Comfort Control at Minimum Operating Cost
- Dual Inducers allow for 81% A.F.U.E. Steady state efficiency at High *and* Low Stage
- Rheem Exclusive In-shot Burners
- Solid State, Direct Spark Ignition with Remote Flame Sense and on-board diagnostics

Cooling

- R410 Refrigerant
- Quiet, Efficient, Scroll® Compressors
- Two-Stage Cooling for Superior Comfort Control at Minimum Operating Cost
- Belt-drive Blower with optional drive to accommodate design conditions as high as 2.0 inches [.37 kPa] of external static pressure at nominal airflow
- Copper Tube/Aluminum Fin Coils

Service Features

- 1/4 turn Fasteners and Hinged Access Panels for Convenience
- Large Control Panel with numbered and color coded wiring for Easy Troubleshooting
- Front Access, Slide-Out Blower Assembly for Easy Maintenance
- Convertible Airflow for Maximum Flexibility
- Solid-State Furnace Controls with Diagnostic L.E.D. for Easy Troubleshooting
- Slide out Condensate Drainpan
- Factory-Installed two-inch [50.8 mm], throw away filters. Accessible without tools

- Externally-mounted refrigerant gauge ports
- Side or Base utility access minimizing roof penetrations
- Full perimeter, forkable, riggable baserails with protective forkboards for easy handling
- Plug-in Electrical Connections on outdoor fan assemblies
- Unit is prewired to accept Slip-in Economizer
- Complete Factory Tested, Charged Wired

Reliability Features

- One-piece Top and Base pan on indoor section. One-inch [25.4 mm] raised flanges on supply/return opening for superior water management
- Aluminized Steel Heat Exchanger helps eliminate corrosion
- Base pan Insulation mounted on bottom helps eliminate corrosion and improves indoor air quality
- Non-Corrosive, sloped drain pan helps improve indoor air quality
- Insulation secured by adhesive *and* mechanical means
- Electrodeposition powder-coat paint process guards against extreme weather conditions and withstands 1000-hour salt-spray test
- Solid core liquid line filters
- High and Low pressure switches

[] Designates Metric Conversions

ACCESSORIES

Factory Installed

- Stainless Steel Gas Heat
- Single Enthalpy w/Barometric Relief
- Single Enthalpy w/Barometric Relief and
Smoke Detector
- Disconnect Switch
- Convenience Outlet (Powered)
- Oversized Blower Motor
- Low Ambient
- Outdoor Coil Guard

Field Installed

- 14" Full Perimeter Roof
- 24" Full Perimeter Roof
- Roof Curb Adapter
- Dual Enthalpy Sensor
- Power Exhaust
- CO₂ Sensor
- Natural Gas High Altitude Kit.....
- Propane Conversion Kit
- Concentric Diffuser
- Low Ambient Kit.....
- Hail Guard
- Manual Outside Air Intake Damper
- Motorized Outside Air Intake Damper.....
- Single Enthalpy w/Barometric Relief
- Single Enthalpy w/Barometric Relief and
Smoke Detector

Before proceeding with installation, refer to installation instructions packaged with each model, as well as complying with all Federal, State, Provincial, and Local codes, regulations, and practices.

Rheem Sales Company, Inc.
P.O. Box 17010, Fort Smith, AR 72917

"In keeping with its policy of continuous progress and product improvement, Rheem reserves the right to make changes without notice."