



# SUBMITTAL COVER SHEET

PROJECT NAME \_\_\_\_\_

LOCATION \_\_\_\_\_

ARCHITECT \_\_\_\_\_

ENGINEER \_\_\_\_\_

CONTRACTOR \_\_\_\_\_

SUBMITTED BY \_\_\_\_\_ DATE \_\_\_\_\_

## UNIT SUMMARY

Quantity						
Unit Designation						
Model No.						
Total Cooling						
Sensible Cooling						
Air Ent. Evaporator						
Air Lvg. Evaporator						
Heating Input						
Heating Output						
CFM/ESP						
EER/SEER						
Electrical						
Minimum Ampacity						
Min.-Max. Breaker						
Net Unit Weight						
Accessory						
Catalog Form Number						

### ACCESSORIES:

### NOTES:

# SUBMITTAL SHEET FOR (-)PQL- JEZ 1 1/2-5 NOMINAL TON [5.28-17.6 kW] 15 SEER REMOTE HEAT PUMP UNITS



for **R-410A**

JOB NAME \_\_\_\_\_ LOCATION \_\_\_\_\_  
 CONTRACTOR \_\_\_\_\_ ORDER NO. \_\_\_\_\_  
 ENGINEER \_\_\_\_\_ SUBMITTED FOR  APPROVAL  RECORD  
 DATE \_\_\_\_\_  
 MODEL NO. \_\_\_\_\_  
 AIR HANDLER MODEL NO. \_\_\_\_\_  
 INDOOR COIL MODEL NO. \_\_\_\_\_

## UNIT DATA

### COOLING PERFORMANCE

EFFICIENCY ..... SEER  
 TOTAL CAPACITY\* ..... MBH [kW]  
 SENSIBLE CAPACITY\* ..... MBH [kW]  
 OUTDOOR DESIGN TEMP. .... °F [°C] DB  
 TEMP. OF AIR ENTERING  
 EVAPORATOR COIL..... °F [°C] DB  
 °F [°C] WB  
 POWER INPUT REQUIREMENT ..... kW  
 (\*uses blower motor heat)

### HEATING PERFORMANCE

EFFICIENCY ..... HSPF  
 TOTAL CAPACITY\* ..... MBH [kW]  
 OUTDOOR DESIGN TEMP. .... °F [°C] DB  
 TEMP. OF AIR ENTERING  
 EVAPORATOR COIL..... °F [°C] DB  
 POWER INPUT REQUIREMENT ..... kW  
 (\*uses blower motor heat)

### SUPPLY AIR BLOWER PERFORMANCE

TOTAL AIR SUPPLY ..... CFM [L/s]  
 TOTAL RESISTANCE EXTERNAL  
 TO UNIT ..... IWG  
 BLOWER SPEED ..... RPM  
 POWER OUTPUT REQUIREMENT .. BHP  
 MOTOR RATING ..... HP [W]  
 POWER INPUT REQUIREMENT ..... kW

### ELECTRICAL DATA

POWER SUPPLY ..... Hz  
 TOTAL UNIT AMPACITY..... AMPS  
 MINIMUM WIRE SIZE ..... AWG  
 MAXIMUM OVERCURRENT DEVICE  
 FUSES/HACR BREAKER ..... AMPS

### CLEARANCES

SERVICE ACCESS 24" [609.6 mm]  
 AIR INLETS 6" [152.4 mm]  
 ABOVE UNIT 60" [1524 mm]

## Equipped with the Award Winning Comfort Control System™



- Increased Reliability
- Fault Recall
- On-Board Diagnostics
- Active Protection™

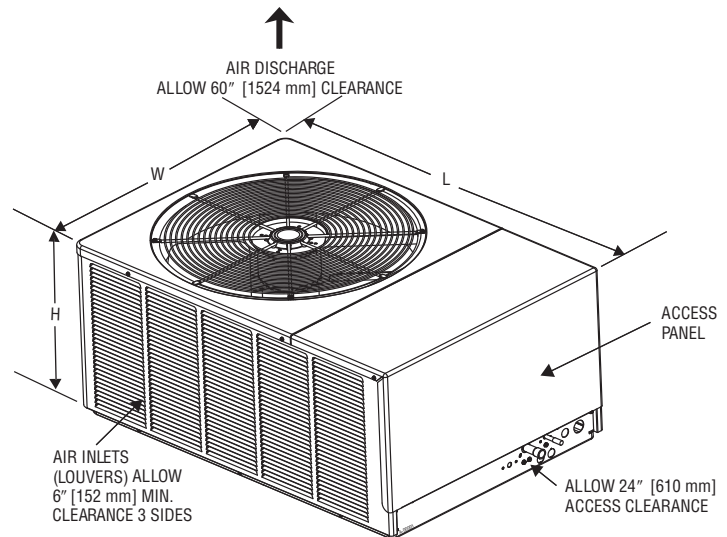

### DIMENSIONS

Model Number (-)PQL-	Height "H" (Inches) [mm]	Length "L" (Inches) [mm]	Width "W" (Inches) [mm]
018JEZ	19 [482]	40 1/2 [1028]	27 5/8 [701]
024JEZ	19 [482]	44 3/8 [1127]	31 1/2 [800]
030JEZ/036JEZ/037JEZ/042JEZ	25 [635]	44 3/8 [1127]	31 1/2 [800]
048JEZ/056JEZ/060JEZ	33 [838]	44 3/8 [1127]	31 1/2 [800]

[ ] Designates Metric Conversions

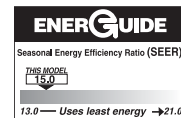

"Proper sizing and installation of equipment is critical to achieve optimal performance. Split system air conditioners and heat pumps must be matched with appropriate coil components to meet ENERGY STAR criteria. Ask your Contractor for details or visit [www.energystar.gov](http://www.energystar.gov)."

**FEATURES FOR (-)PQL- JEZ REMOTE HEAT PUMPS  
1 1/2 TO 5 NOMINAL TONS [5.28 to 17.58 kW]**

- The *Comfort Control System*™ provides on-board diagnostics and fault history for heat pumps with single-phase compressors by detecting system and electrical problems without adding sensors. It can also communicate “fault codes” to enabled “L terminal” thermostats. The integrated diagnostics with *Active Protection* prevents compressor operation when potentially harmful conditions are detected.
- Features an exclusive 7-Segment LED Display. The information-display quickly and accurately shows technicians the source of malfunctions.
- Scroll Compressor
- Copper Tube/Aluminum Fin Coils
- Powder painted louvered steel cabinet protects the coil from damage
- Internal Check Valve
- Enhanced Compressor Protection
- Manual Reset High Pressure Control
- Drawn Painted Base Pan
- Hard Start Components
- Non-Cycling Reversing Valve
- Hot Gas Muffler
- Bi-Directional Filter Drier (shipped – not installed)
- Service Valves
- TEV Refrigerant Metering

- Demand Defrost Control
- All refrigerant connections are on the exterior of the unit, located close to the ground for neat appearing installations
- Coil design permits compressor operation with the access panel removed
- Control box is fully accessible in the upper part of the cabinet
- Power and control wiring are kept separate
- Certified and rated under AHRI Standard 240
- U.L. listed
- Factory run tested prior to shipment
- Factory limited warranty as follows:
  - Compressor .....Ten (10) Years
  - Any Other Part .....Ten (10) Years

**(-)PQL- JEZ Conditional Replacement Warranty:**

A replacement model will be provided (if an exact replacement is not available, an equivalent product will be provided) to the original purchaser if the compressor fails within 5 years. See product warranty card for additional information.

**FIELD INSTALLED ACCESSORIES**

- Low Ambient Control .....
- Thermostats .....
- Blower Time Delay Control .....

- Fossil Fuel Kit .....
- Compressor Crankcase Heater .....

**SPECIAL NOTES ON EQUIPMENT:**

**Before proceeding with installation, refer to installation instructions packaged with each model, as well as complying with all Federal, State, Provincial, and Local codes, regulations, and practices.**

Rheem Sales Company, Inc.  
P.O. Box 17010, Fort Smith, AR 72917

*“In keeping with its policy of continuous progress and product improvement, Rheem reserves the right to make changes without notice.”*