



The new degree of comfort.™



Commercial Gas  
VentMaster Water Heaters

# VentMaster™ is a series of power direct vent commercial gas water heaters that are a good choice for buildings with tight construction or when indoor air quality is a concern

## Features & Benefits

VentMaster power direct vent commercial water heaters provide outside air for combustion, which eliminates negative air pressure issues in tight construction. Models are available in 199,900 and 250,000 Btu/h, with a maximum temperature setting of 180 degrees Fahrenheit.

## Thermal Efficiency

Meets or exceeds a minimum of 80% (non-condensing)

## System Sentinel™ LED Diagnostic System

Our exclusive diagnostic system, with glowing LED lights, verifies system operation sequence by sequence.



## Patented Technology

Patented multi-flue tank design has a proprietary steel formulation with two coats of high temperature porcelain enamel to maximize corrosion resistance. This results in a superior, long lasting heat exchanger.

## Integral Automatic Blower

The 120 Volt blower assists in quietly discharging combustion gases.

## Gas Control System

The control system has a fully adjustable thermostat from 100° F to 180° F. The 24 volt combination gas valve includes main gas pressure regulation and an on-off manual valve. The 120/24 volt transformer and high limit cut-out allow for accurate and safe temperature settings.

## Easier, Less Costly Venting

Installs with 3" or 4" Schedule 40 PVC pipe; no masonry or metal vent chimney is required. Can be installed virtually anywhere. Maximum vent length is 50 feet.

## Base Rail Design

Provides better handling when moving the unit.

## Full-port, Full-flow Drain Valve

Factory installed brass drain valve allows for faster draining and servicing.

## Direct Spark-to-Pilot Ignition System

Less fuel consumption

## Altitude Certification

Standard models certified up to 2,000 feet; high altitude models available up to 8,000 feet

## CSA/ASME Rated T&P Valve

Factory installed relief valve

## Hand-hole Cleanout

Easy removal of sediment deposits

## Warranty

3-Year limited tank warranty, upgradeable to 5 years

See Commercial Warranty Certificate for complete information.

**Efficiency** | All models tested according to ANSI test procedures, and meet or exceed the thermal efficiency and standby loss requirements of ASHRAE standard (EPact). Also exceeds energy efficiency codes of all states including California Energy Commission (CEC).

**Safety and Construction** | Design certified by CSA: For operation at 180 degrees; meets all safety and construction requirement of ANSI Z21.10.3; as an automatic storage or instantaneous water heater; as an automatic circulating tank water heater; and for operation on combustible floors and in alcove installations. All models are North Carolina Code compliant. **Certified for 150 PSI maximum working pressure (160 PSI for ASME models).**

**Optional ASME Construction** | ASME construction is available on designated models.

Not available in Canada.



## Rheem VentMaster

100-Gallon Capacity  
199,900-250,000 Btu/h  
Natural and LP Gas  
120V/1.5 Amp Blower  
No Chimney Required



(On Selected Models)



INTEGRATED AIR & WATER



The new degree of comfort.™



Commercial Gas  
VentMaster Water Heaters

RECOVERY CAPACITIES in U.S. Gals/Hr. (GPH) and Liters/Hr. (LPH) at various temperature rises.													
MODEL NUMBER	INPUT BTU/HR.	UNITS	40°F	50°F	60°F	70°F	80°F	90°F	100°F	110°F	120°F	130°F	140°F
			(22°C)	(28°C)	(33°C)	(39°C)	(45°C)	(50°C)	(56°C)	(61°C)	(67°C)	(72°C)	(78°C)
GP100-200	199,900	GPH	485	388	323	277	242	215	194	176	162	149	138
		LPH	1838	1471	1224	1050	917	815	735	667	45	565	523
GP100-250(A)	250,000	GPH	606	485	404	346	303	269	242	220	202	186	173
		LPH	2294	1835	1529	1311	1147	1020	918	834	765	706	655

CLEARANCE TO COMBUSTIBLES (inches)			
MODEL NUMBER	SIDE	REAR	TOP
GP100-200	2"	6"	18"
GP100-250(A)	51mm	153mm	459mm

MAXIMUM DELIVERY In U.S. Gallons and Liters. (Includes useable storage and recovery for indicated times.)												
MODEL NUMBER	TANK CAP. GALLONS	INPUT BTU/HR.	TEMP. RISE	UNITS	5 MIN.	10 MIN.	15 MIN.	20 MIN.	30 MIN.	45 MIN.	60 MIN.	MINUTES TO REC. CONTENTS
GP100-200	100	199,900	100 °F	GAL	86	102	118	135	167	215	264	31
			37.7 °C	LTR	326	387	448	510	632	815	999	
GP100-250(A)	100	250,000	100 °F	GAL	90	110	131	151	191	252	312	25
			37.7 °C	LTR	341	418	494	571	724	953	1183	

DIMENSIONAL INFORMATION All dimensions in English and Metric units.											
MODEL NUMBER	UNITS	A	B	C	D	E	F	G	WATER CONNECTIONS		APPROXIMATE SHIPPING WEIGHT
									FRONT IN/OUT	REAR SIDE	
GP100-200	inches	81-3/4	68-1/4	30-1/4	24-3/4	3	59	3/4	2	2	860 lbs.
	mm	2076	1734	768	629	76	1499	19	51	51	390 kgs.
GP100-250(A)	inches	81-3/4	68-1/4	30-1/4	24-3/4	4	59	3/4	2	2	860 lbs.
	mm	2076	1734	768	629	101	1499	19	51	51	390 kgs.

(A) suffix indicates ASME tank construction available.

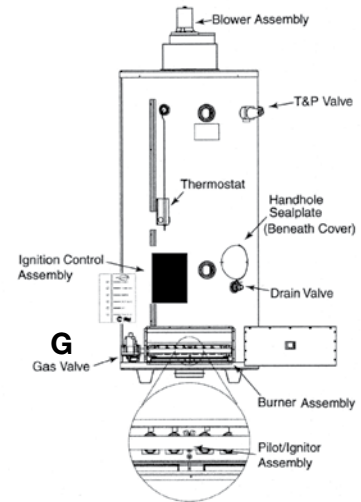
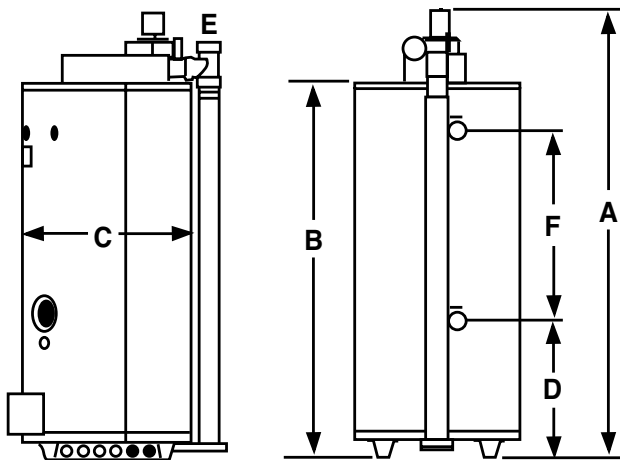

**Recommended Specifications (for trade reference only)**

Water heater(s) shall be model \_\_\_\_\_, manufactured by Rheem, having gas input of \_\_\_\_\_ Btu/h and a recovery rate of \_\_\_\_\_ GPH at a 100°F temperature rise. Water heater shall have a storage capacity of \_\_\_\_\_ gallons. Water heater shall have the CSA seal of certification and be factory equipped with a CSA/ASME rated temperature and pressure relief valve. Tank shall have a coating of high temperature porcelain enamel and furnished with a magnesium anode rod rigidly supported. Water heater shall meet or exceed the energy factor requirements of ASHRAE. Tank shall have a working pressure rating of 150 psi, and shall be completely factory

assembled, including a pressure regulator properly adjusted for operation on natural gas with a stainless steel burner. Water Heater shall have a spark-to-pilot ignition system. Controls will be arranged for safety shutoff in event of pilot failure. Complete unit shall be insulated with fiberglass insulation. Water Heater shall be covered by a three year limited warranty against tank leaks.

**When ordering ASME construction, place (A) after the model number (for trade reference only)**

Water heater(s) shall be constructed in accordance with the requirements of the ASME Boiler and Pressure Vessel Code, Section IV Part HLW.

In keeping with its policy of continuous progress and product improvement, Rheem reserves the right to make changes without notice.

Rheem Water Heating • 101 Bell Road  
Montgomery, Alabama 36117-4305 • www.rheem.com



INTEGRATED AIR & WATER