

Central Station **AIR HANDLING UNITS**

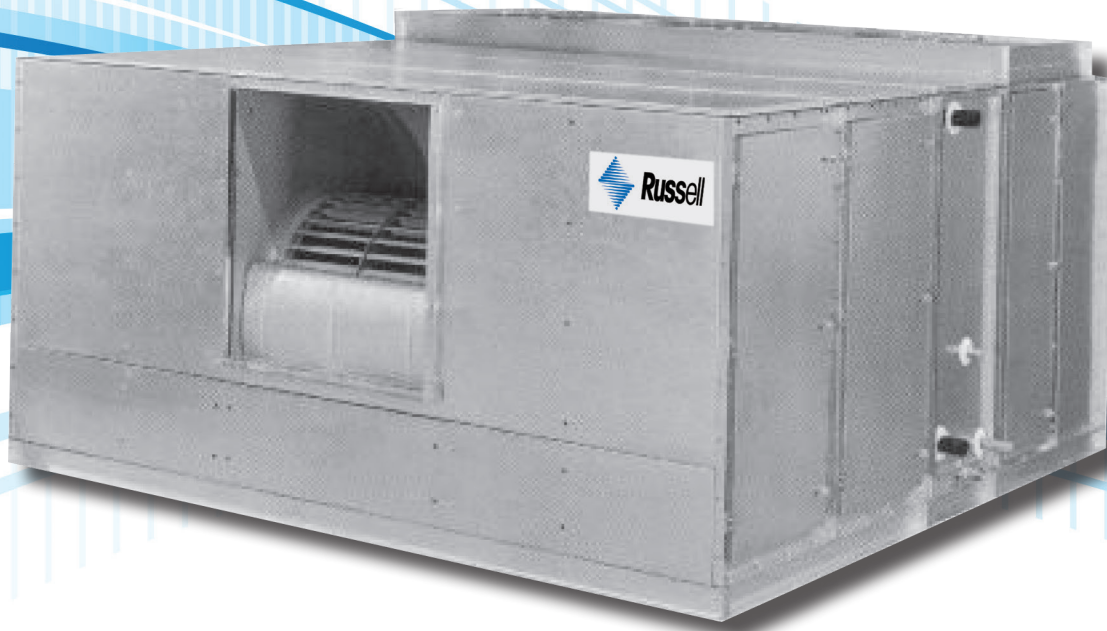

Complete HVAC Capability

- Horizontal Draw-Thru to Size 65
- Vertical Draw-Thru to Size 50
- 1000 to 60,000 CFM
- Forward Curved or Airfoil Wheels
- Inlet Vane Option
- Internal Vibration Isolation Option

CENTRAL STATION AIR HANDLER

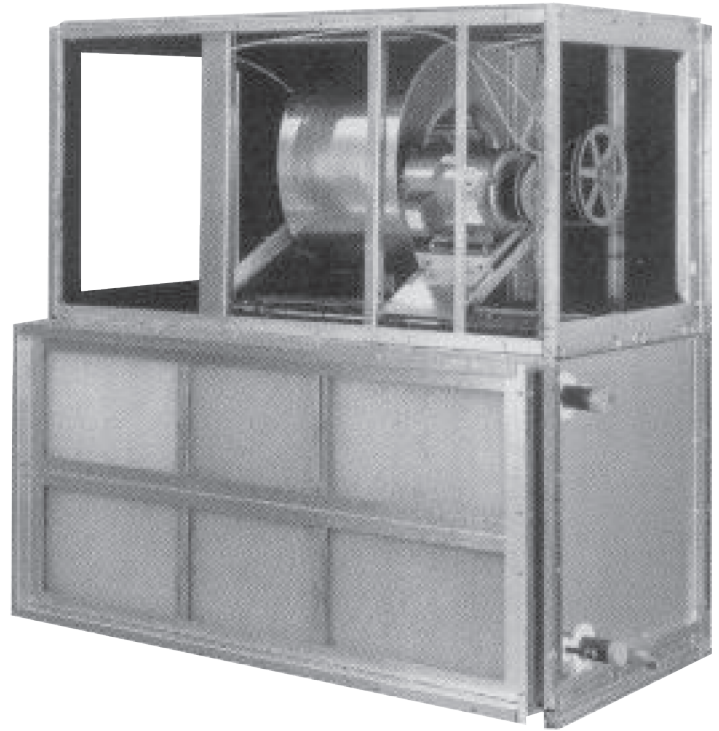

Vertical Configuration
External Vibration Isolation

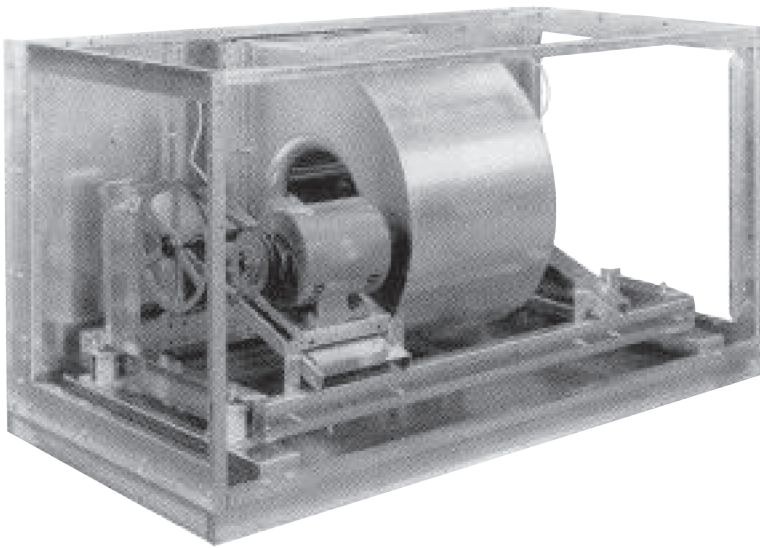

Horizontal Configuration
Internal Vibration Isolation

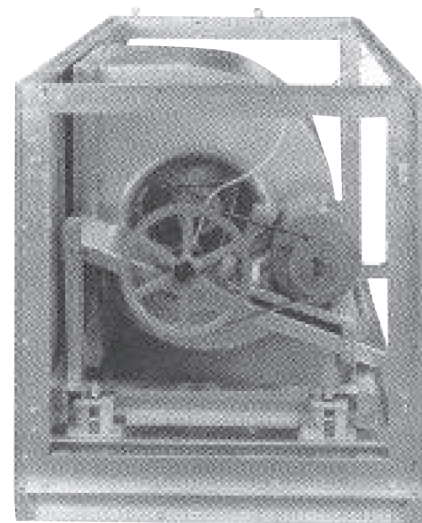

Internal Configuration
Construction Detail

CENTRAL STATION AIR HANDLER

MODEL NUMBER NOMENCLATURE

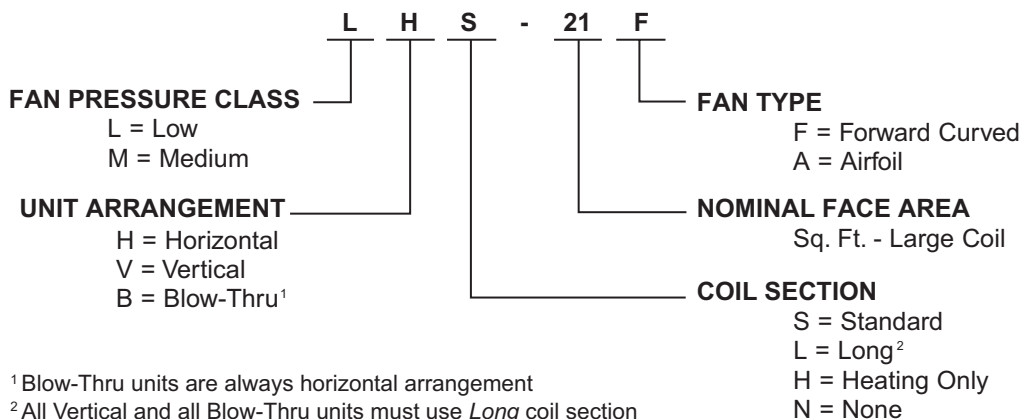

General Description

The Central Station Air Handler is an industrial grade product with heavy gauge mill-galvanized steel framing and sheet metal throughout. Designed specifically for the HVAC industry with a full range of options and accessories, these units are also ideal for custom or design-and-build projects in refrigeration or air conditioning.

Units are a single blower, internally mounted motor design. Each blower section has hinged access panels on both sides for service convenience. Air conditioning units are available for both low and medium pressure applications.

The standard configurations available in most models include forward curved and airfoil wheels, with or without inlet vanes; horizontal and vertical draw-thru and horizontal blow-thru; internal or external fan isolation.

Continuous diameter solid steel blower shafting is used throughout the line, resulting in large bearing diameters and low bearing loads. The highest quality grease lubricated bearings are selected to assure 200,000 hours average service life. Each rotating assembly, including fan wheel, shaft, sheaves, belts and motor, is balanced after final assembly to assure smooth, quiet performance.

Standard coil options include chilled water or direct expansion cooling coils; hot water, steam and heat reclaim heating coils plus electric heat sections to provide complete comfort and environmental conditioning.

General Performance Data

Model Size	CFM Range Cooling Thru Heating	Nominal Capacity (Large Coil) - MBH*				Large Coil Face Area Sq. Ft.	Dimensions †		
		A (Water)	B (Dir Exp)	C (Dir Exp)	Heating		Length (Inches)	Width (Inches)	Height (Inches)
03	900-2600	47.0	47.4	45.2	71.0	3.1	44	45	23 5/8
06	1700-4700	84.0	80.8	77.1	125.0	5.5	47	59	26 5/8
08	2200-6700	121.0	122.7	117.0	181.0	8.0	53	63	32 5/8
10	2900-8500	152.0	148.6	141.8	227.0	10.0	59	63	38 5/8
12	3400-10200	178.0	178.7	170.5	269.0	11.9	59	72	38 5/8
14	4000-12000	210.0	202.4	193.1	312.0	13.8	59	81	38 5/8
17	5100-14700	263.0	257.3	245.4	391.0	17.3	65	84	45 5/8
21	6100-18000	320.0	305.1	290.0	476.0	21.0	65	99	45 5/8
25	7000-21000	373.0	371.4	354.2	555.0	24.5	71	99	52 5/8
31	9000-26000	475.0	468.5	446.9	714.0	31.5	71	123	52 5/8
36	11000-28000	550.0	561.8	535.9	816.0	36.0	79	123	60 5/8
41	12000-34500	615.0	629.6	600.6	918.0	40.5	86	123	67 5/8
50	15000-40500	750.0	771.7	736.1	1122.0	49.5	96 1/2	123	78 1/8
65	19525-52200	988.0	1018.6	971.8	1479.0	65.3	96 1/2	123	99 1/8

* Cooling Capacity
4 row 8 FPI Coil @ 500 FPM Air Velocity:

A (Water) 80° DB/67° WB Ent. Air, 2.4 GPM/Ton, 45° Ent. Water
B (Dir Exp) 80° DB/67° WB Ent. Air, 45° Refrigerant Temperature
C (Dir Exp) 75° DB/62.5° WB Ent. Air, 40° Refrigerant Temperature

Heating Capacity
1 Row 8 FPI Coil @ 500 FPM Air Velocity:

Steam 60° DB Entering Air, 5 PSIG Steam

† Width is left-to-right dimension facing blower discharge. Length includes fan & standard coil section (Horizontal Arrangement)

CENTRAL STATION AIR HANDLER

Standard Construction and Features

- Nut & Bolt Construction (except filter racks riveted inside of filter section)
- Heavy Gauge Mill-Galvanized Steel Sheet Metal & Framing
- Single Blower-Wheel Design
- Solid Steel Fan Shafts; Continuous Diameter, Turned, Ground & Polished
- Pillow-Block Bearings; 200,000 Average Service Life
- Lube Lines for blower Bearings Extended to Outside
- Internally Mounted Motor
- Adjustable Motor Base
- Blower & Drive Components Dynamically Balanced after Fabrication
- Hinged Access Doors w/easy Lift-Off Feature
- Double Drain Pan (insulated between pan and outer casing)

Configuration and Option Availability

DESCRIPTION	UNIT SIZE													
	03	06	08	10	12	14	17	21 S*	21 O*	25	31	36	41	50

General

CONFIGURATIONS - FORWARD CURVE FAN															
Horizontal Draw- Thru	A	A	A	A	A	A	A	A	A	A	A	A	A	A	A
Vertical Draw- Thru	A	A	A	A	A	A	A	A	A	A	A	A	A	A	A
Horizontal Blow- Thru (Includes diffuser section)		A	A	A	A	A	A	A	A	A	A	A	A	A	
CONFIGURATIONS - AIRFOIL FAN															
Horizontal Draw- Thru							A	A	A		A	A	A	A	A
Vertical Draw- Thru							A	A	A		A	A	A	A	A
Horizontal Blow- Thru (Includes diffuser section)							A	A	A		A	A	A	A	A
Ceiling or Floor Mounting	A	A	A	A	A	A	A	A	A	A	A	A	A	A	A
Floor or Platform Mount ONLY															A
Weatherproofing	A	A	A	A	A	A	A	A	A	A	A	A	A	A	A
Insulation	Std. No Insulation: 1" - 2.2# and 1" - 3# (Foil Faced) are optional														
HH-LP, HN-LP & HB-LP Fan Sections Only	1" - 2.2# Standard; 1" - 3# (Foil Faced) optional														
All Other Models (Fan and coil sections)															

Fan Section

LOW PRESSURE CLASS	Available for all forward curve fans Available for all airfoil fans														
Forward Curve Fans															
Airfoil Fans															
MEDIUM PRESSURE CLASS	Available for all forward curve fans Available for all airfoil fans														
Forward Curve Fans															
Airfoil Fans															
INLET VANES	Available for all forward curve fans (Except sizes 03 & 06) Available for all airfoil fans														
Forward Curve Fans															
Airfoil Fans															
INTERNAL FAN ISOLATION															
Forward Curve Fans	A	A	A	A	A	A	A	A	A	A	A	A	A	A	A
Airfoil Fans							A	A	A	A	A	A	A	A	A
MOTORS	Available All Sizes														
Left or Right Hand Location															
Standard Open Drip Proof															
High Efficiency															
Totally Enclosed - Fan Cooled															
Two-Speed															
DRIVES															
Fixed or Adjustable															
125% or 150% Service Factor															
Dual Drive (Motor & Drive on each side of blower)								A	A	A	A	A	A	A	A
Motor Starter	A	A	A	A	A	A	A	A	A	A	A	A	A	A	A
OSHA Belt Guard	A	A	A	A	A	A	A	A	A	A	A	A	A	A	A

*S = Standard 20" blower; O = Optional 22" blower A = Available

CENTRAL STATION AIR HANDLER

Configuration and Option Availability

DESCRIPTION	UNIT SIZE													
	03	06	08	10	12	14	17	21 S*	21 O*	25	31	36	41	50

Coil Section

LENGTH (in direction on air flow)															
Standard	A	A	A	A	A	A	A	A	A	A	A	A	A	A	A
Long	A	A	A	A	A	A	A	A	A	A	A	A	A	A	A
Extra Large Face (Furnished with piping vestibule) (Available with standard or long sections)						A	A	A	A	A	A	A	A	A	A
Heating Only (Short section with no insulation)	A	A	A	A	A	A	A	A	A	A	A	A	A	A	A
DRAIN PAN	Available All Sizes														
Mastic Coated															
Stainless Steel															
Coil Spacer															

Accessory Sections

FLAT FILTER SECTION (For 2" Filters) Throwaway, Cleanable & Pleated Filters	Available All Sizes														
FLAT FILTER SECTION (For 4" Filters) Pleated Filters Only															
ANGULAR FILTER SECTION (For 2" Filters) Throwaway, Cleanable & Pleated Filters															
HEAVY DUTY FILTER SECTION Throwaway, Cleanable & Pleated Filters				A	A	A	A	A	A	A	A	A	A	A	A
BAG FILTER SECTION (For 22" Bags & Pre-Filters) 65%,85% & 95% Efficient Filters	A	A	A	A	A	A	A	A	A	A	A	A	A	A	A
CARTRIDGE FILT. SECT. (For 12" Cart. & Pre-Filters) 60%, 80% & 90% Efficient Filters	A	A	A	A	A	A	A	A	A	A	A	A	A	A	A
MIXING BOX With or Without Dampers With or Without 2" Filter Racks Low Leak Dampers	Available All Sizes														
FACE & BYPASS DAMPER SECTION Internal External															
FACE DAMPER SECTION Standard Dampers Low Leak Dampers															

*S = Standard 20" blower; O = Optional 22" blower A = Available

Coil Construction and Options

Standard Construction

- Copper Tubing – Staggered Tube Pattern
- Die-formed Plate – Type Aluminum Fins
- Mill-galvanized Steel Casing – 16 gauge
- Heavy Wall Copper Headers
- Connections:
 - Water & Steam Coils: Steel MPT
 - Direct Expansion: Distributor inlet
 Sweat Copper Suction
 - Condenser & Reclaim: Sweat Copper
- Leak Tested Under Water @ 400 PSIG Dry Nitrogen

Optional Features

- 3/8", 1/2" & 5/8" Tubing (except steam is (5/8" O.D. only)
- .025", .035" and .049" Wall Copper Tubes (5/8" O.D. only)
- 4 Thru 14 Fins Per Inch
- Copper Fins, Polyester Coated Fins
- .010" thick Aluminum Fins
- Phenolic Coated Coil – Dipped After Fabrication
- Type 304 Stainless Steel Casing
- Copper MPT Connections in lieu of Steel
- Additional circuits: Face Split
 Row Split
 Intertwined

CENTRAL STATION AIR HANDLER

Mechanical Specifications

General

Each unit shall be furnished with components as specified. All units and accessories shall be constructed of heavy gauge galvanized steel as specified in the Physical Data table on the back cover on this brochure.

Fan Section

Fan section shall have an access door on each side secured by quick-release latches. Hinges shall be of the slip joint type allowing easy removal of doors. All doors shall be generously gasketed.

Fan sections used in cooling application shall be internally insulated with standard 1" inch thick, 2.2 lb. (optional 1 inch 3 lb. foil-faced) bonded mat fiberglass insulation, affixed with a waterproof adhesive. All insulation shall comply with the requirements of NFPA 90.

Fan sections for heating and ventilating units are not insulated except as specified option.

Coil Section

Heating and cooling - Cooling coil sections shall be internally insulated with standard 1" inch thick, 2.2 lb. (optional 1 inch 3 lb. foil-faced) bonded mat fiberglass insulation, affixed with a waterproof adhesive. Insulation shall comply with the requirements of NFPA 90. Heating and ventilating coil sections are not insulated.

Horizontal unit arrangements shall be available with standard and long coil sections. Vertical unit arrangements shall be available with a long coil section only.

Coil sections with coils higher than 42-inch finned height shall have an intermediate drain pan (between top and bottom coils) with plastic drain tubes extending into main drain pan.

Heating coils shall be considered standard in either the preheat or reheat position. Cooling coils shall be mounted on entering air side of coil section to prevent water carryover into the fan section.

Standard and long coil sections shall have a removable panel on each side to allow easy coil access and removal. Optional hinged and latched access door available on return-bend side of coil section.

Standard and long coil sections shall have a double drain pan with insulation between the inner and outer pan. The drain pan shall have welded corners and a 1-1/4 inch MPT drain connection on each side for positive draining. Optional stainless steel drain pans for corrosive applications.

Heating-Only Coil Section

One and two row heating coils can be housed in a specially designed slide-in casing and bolted directly to the fan section. Heating only coils with more than two rows shall be bolted directly to the fan section without a casing. No insulation can be applied.

Blowers

Each unit shall contain one forward curved, double width, double inlet blower. Blower wheel and housings are heavy gauge galvanized steel. All fans available with standard or Class II; forward curved or airfoil wheels.

Blower wheels shall be statically and dynamically balanced before they are assembled and dynamically balanced after being installed in the fan section.

Fan Shaft

Shafts shall be solid steel, continuous diameter, turned, ground and polished. Each shaft shall be coated with a non-hardening rust inhibitor.

Shaft critical speed shall be at least 1.25 times the maximum operating speed.

Bearings

Pillow block bearings shall be self-aligning, noise tested and have air conditioning fit. Average bearing life shall be in excess of 200,000 hours.

Extended lube lines and grease fittings shall be furnished to each bearing to allow lubrication from outside the cabinet.

Coils

All coils shall be staggered tube design, have heavy wall copper headers, and die-formed plate type aluminum fins. Coil casings shall be constructed of 16 gauge galvanized steel.

Water and steam coils shall have steel MPT connections. DX and heat reclaim coils shall have copper sweat connections.

All coils shall be submerged in water and leak tested with 400 PSIG dry nitrogen.

Face and Bypass Dampers

Dampers shall be internal or external, opposed blade type with inter-connecting linkage. Blade bearings shall be brass inserts and shall provide smooth operation and corrosion resistance. Small face area coils with internal bypass; large face area coils with external bypass. The external duct on external bypass to be insulated.

CENTRAL STATION AIR HANDLER

Mechanical Specifications

Mixing Box

Mixing box can be furnished with or without an angular filter section and have either top and back or bottom and back openings. Openings can be furnished with or without parallel blade dampers, having standard or low leak dampers. Blade bearings shall be brass inserts and shall provide smooth operation and corrosion resistance.

Section to have full access doors on each side with slip-joint hinges, quick-release latches and gasketing.

Drive

Drive components shall be of the highest quality and statically balanced. Drives are designed to be a minimum of 1.20 or 1.50 times the rated motor horsepower.

Motors

Motors shall be mounted inside the blower section, on a heavy gauge steel channel, with the drive side out to provide access to the drive. Optional 1" internal spring vibration isolators for sizes 14 - 65 and rubber-in-shear isolators for sizes 03 - 12.

Flat Filter Section

Section available for 2" thick throwaway, cleanable, or 30% efficient pleated-media type filters.

Section available with 4" thick 30% efficient pleated-media type filters. Sections have full access both sides with removable doors with slip-joint hinges, quick-release latches and gasketing. Filter velocities not to exceed recommended maximum face velocities.

Angular Filter Section

Section available for 2" thick throwaway, cleanable or 30% efficient pleated-media type filters. Sections have full access both sides with removable doors with slip-joint hinges, quick release latches and gasketing. Filter velocities not to exceed recommended maximum face velocities.

Electric Heat Section

Section shall be of open coil heater type and shall have external control panel. All heating sections shall be supplied with internal wiring of controls & contactors. Automatic reset thermal cut-out and air flow pressure switch.

Access Section

Used where access is needed to a particular area. Full access both sides with removable doors with slip-joint hinges, quick-release latches and gasketing.

Diffuser Section

Factory installed with perforated plate to assure even distribution of discharge air across coil, required for proper heat transfer.

Bag Filter Section

Each section has full size gasketed doors for access on both sides. Unit equipped with 2" pre-filter track and 22" bag filters. Cartridge Filter Sections have tracks for 12" Cartridges.

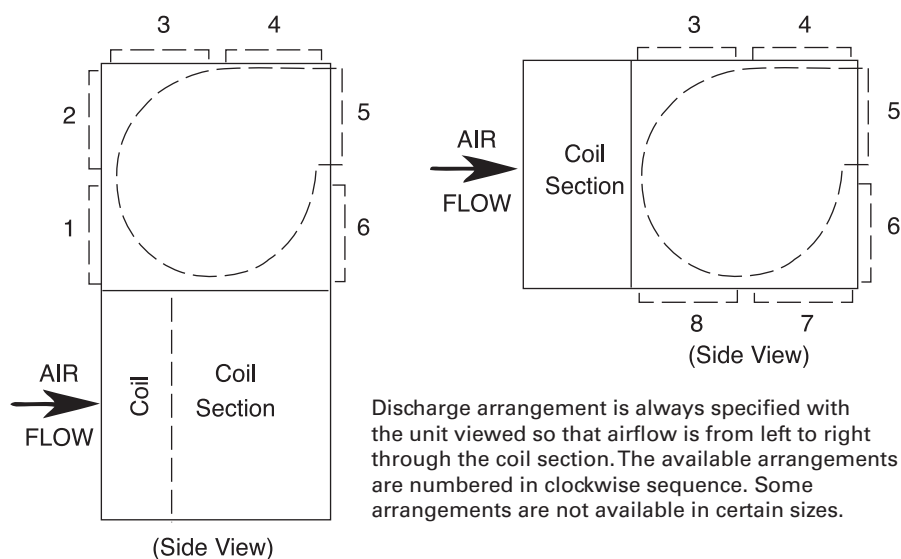

NOTE: Motor and coil connection locations are specified looking into the return air intake of the unit.

CENTRAL STATION AIR HANDLER

Physical Data

DESCRIPTION	UNIT SIZE														
	03	06	08	10	12	14	17	21 (Std.)	21 (Opt.)	25	31	36	41	50	65
CFW-Air Conditioning	900-1900	1700-3300	2200-4900	2900-6100	3400-7000	4000-9000	5100-10500	6000-12400	6000-12400	9000-15000	9000-19000	11000-22000	12000-24000	15000-30000	17500-34500
CFM-Heating & Ventilating	900-2600	1700-4700	2200-6700	2900-6500	3400-10200	4000-11500	5100-16500	6000-19600	6000-19600	7000-23000	9000-28200	11000-32600	12000-36700	15000-45000	17500-59500
Fan Diameter - in. (All units - one fan)	9	12	15	15	18	18	20	20	22	25	25	30	30	36	-
Outlet Area - Draw Thru (Sq. Ft.)	.84	1.46	2.05	2.05	3.26	3.26	4.01	4.01	5.16	6.78	6.78	9.10	9.10	10.96	-
Outlet Area - Blow Thru (Sq. Ft.)	1.75	2.72	4.17	4.17	5.75	5.50	7.88	12.00	12.00	12.00	16.67	16.67	16.67	-	-
Shaft & Bearing Dia. (in.)	1	1	1.7/16	1.7/16	1.7/16	1.7/16	1.7/16	1.7/16	1.7/16	1.11/16	1.11/16	1.15/16	1.15/16	1.15/16	-
Maximum Motor Frame Size	145T	184T	213T	215T	215T	215T	256T	256T	256T	286T	286T	326T	326T	326T	-
Fan Diameter - in. (All units - one fan)	-	-	-	-	-	18	19.5	19.5	-	24	24	26.5	29	35.5	39.5
Outlet Area - Draw Thru (Sq. Ft.)	-	-	-	-	-	3.45	4.14	4.14	-	6.21	6.21	7.54	9.33	13.80	16.77
Outlet Area - Blow Thru (Sq. Ft.)	-	-	-	-	-	6.50	7.88	12.00	-	12.00	16.67	16.67	16.67	-	-
Shaft & Bearing Dia. (in.)	-	-	-	-	-	1.15/16	1.15/16	1.15/16	-	2.7/16	2.7/16	2.7/16	2.7/16	2.7/16	2.11/16
Maximum Motor Frame Size	-	-	-	-	-	215T	254T	256T	-	286T	286T	326T	326T	326T	326T
Extra Large Coil (XLC)	-	-	-	-	-	30 x 74.5	36 x 77.5	36 x 92.5	36 x 92.5	42 x 92.5	42 x 116.5	(2) 24 x 116.5	(2) 27 x 116.5	(2) 33 x 116.5	(1) 42 x 116.5
Face Area (Sq. Ft.)	-	-	-	-	-	15.5	19.4	23.1	23.1	27.0	34.0	38.8	43.7	53.4	70.4
Large Coil (LC)	15 x 30	18x44	24 x 48	30 x 48	30 x 57	30 x 66	36 x 69	36 x 84	36 x 84	42 x 84	42 x 108	(2) 24 x 108	(2) 27 x 108	(2) 33 x 108	(1) 42 x 108
Face Area (Sq. Ft.)	3.1	5.5	8.0	10.0	11.9	13.8	17.3	21.0	21.0	24.5	31.5	36.0	40.5	49.5	65.25
Small Coil (SC)	12 x 30	15x44	18 x 48	24 x 48	24 x 37	24 x 66	30 x 69	30 x 84	30 x 84	33x84	33 x 108	39 x 108	42 x 108	(2) 27 x 108	(2) 33 x 108
Face Area (Sq. Ft.)	2.5	4.6	6.0	8.0	9.5	11.0	14.4	17.5	17.5	19.3	24.8	29.3	31.5	40.5	49.5
Boil-On Coil	18 x 42	21 x 56	27 x 60	33 x 60	33 x 69	33 x 78	39 x 81	39 x 96	39 x 96	45 x 96	45 x 120	49.5 x 120	57 x 120	67.5 x 120	90 x 120
Face Area (Sq. Ft.)	5.3	4.6	6.0	8.0	9.5	11.0	14.4	17.5	17.5	19.3	24.8	29.3	31.5	40.5	49.5
Flat Filter Section	(2) 20x20x2	(2) 20x20x2	(3) 20x25x2	(6) 16x20x2	(4) 16x25x2	(6) 16x25x2	(8) 20x20x2	(8) 20x20x2	(8) 20x20x2	(6) 16x20x2	(6) 20x20x2	(12) 20x25x2	(12) 20x20x2	(6) 20x20x2	(6) 20x20x2
Filter Area (Sq. Ft.)	5.55	7.78	10.42	13.33	15.55	16.67	22.22	26.67	26.67	30.0	37.5	41.67	46.67	58.83	75.0
Angular Filter Section	(4) 16x20x2	(2) 16x20x2	(6) 20x20x2	(6) 20x25x2	(2) 20x25x2	(2) 16x25x2	(8) 20x25x2	(2) 16x25x2	(2) 16x25x2	(4) 16x20x2	(24) 16x20x2	(24) 16x20x2	(24) 20x20x2	(24) 20x25x2	(6) 20x20x2
Filter Area (Sq. Ft.)	8.89	15.55	16.66	20.83	23.61	26.38	27.78	33.33	33.33	42.22	53.3	53.33	66.67	83.33	100.0
Hvy. Duty Filter Section	-	-	-	(9) 20x20x2	(9) 16x20x2	(3) 20x20x2	(12) 20x25x2	(3) 16x25x2	(3) 16x25x2	(3) 16x25x2	(18) 16x25x2	(24) 20x25x2	(24) 20x25x2	(30) 20x25x2	(36) 20x25x2
Filter Area (Sq. Ft.)	-	-	-	25.0	28.33	31.66	41.67	50.0	50.0	50.0	62.5	66.67	83.33	104	125.0
Bag Filter (2" Bags & 2" Pre-Filt.)	(1) 12x24	(1) 12x24	(3) 12x24	(3) 12x24	(3) 12x24	(3) 12x24	(2) 12x24	(6) 24x24	(8) 24x24	(8) 24x24	(10) 24x24	(5) 12x24	(10) 24x24	(15) 24x24	(20) 24x24
Section	6.0	10.0	14.0	14.0	18.0	18.0	28.0	32.0	32.0	32.0	40.0	50.0	50.0	60.0	80.0
Cartridge Filter (12" Cart. & 2" Pre-Filt.)	(1) 12x24	(1) 12x24	(3) 12x24	(3) 12x24	(3) 12x24	(3) 12x24	(2) 12x24	(6) 24x24	(8) 24x24	(8) 24x24	(10) 24x24	(5) 12x24	(10) 24x24	(15) 24x24	(20) 24x24
Filter Area (Sq. Ft.)	6.0	10.0	14.0	14.0	18.0	18.0	28.0	32.0	32.0	32.0	40.0	50.0	50.0	60.0	80.0
Fan Panel	16	16	14	14	14	14	14	14	14	14	14	14	14	14	14
Removable Panels	18	18	18	18	18	18	18	18	18	18	18	18	18	18	18
Base Rails	10	10	10	10	10	10	10	10	10	10	10	10	10	10	10
Bearing/Motor Supports	12	12	12	12	12	12	12	12	12	12	12	12	12	12	12
Drain Pan	16	16	16	16	16	16	16	16	16	16	16	16	16	16	16
Filter Section Panels	18	18	18	18	18	18	18	18	18	18	18	18	18	18	18
Mixing Box Panels	18	18	18	18	18	18	18	18	18	18	18	18	18	18	18
Damper Blades	16	16	16	16	16	16	16	16	16	16	16	16	16	16	16

*S = Standard 20" blower; 0 = Optional 22" blower