



Real People. Real Savings. Real Fast.®

SUBMITTAL COVER SHEET

PROJECT NAME _____

LOCATION _____

ARCHITECT _____

ENGINEER _____

CONTRACTOR _____

SUBMITTED BY _____ DATE _____

UNIT SUMMARY

Quantity						
Unit Designation						
Model No.						
Total Cooling						
Sensible Cooling						
Air Ent. Evaporator						
Air Lvg. Evaporator						
Heating Input						
Heating Output						
CFM/ESP						
EER/SEER						
Electrical						
Minimum Ampacity						
Min.-Max. Breaker						
Net Unit Weight						
Accessory						
Catalog Form Number						

ACCESSORIES:

NOTES:

SUBMITTAL SHEET FOR SA16 1 1/2 TO 5 NOMINAL TON [5.28 TO 17.6 kW], EFFICIENCIES UP TO 16 SEER/13 EER AIR CONDITIONER UNITS

JOB NAME _____ LOCATION _____
 CONTRACTOR _____ ORDER NO. _____
 ENGINEER _____ UNIT MODEL NO. _____
 SUBMITTED FOR APPROVAL RECORD COIL MODEL NO. _____
 DATE _____ AIR HANDLER MODEL NO. _____

UNIT DATA

COOLING PERFORMANCE

EFFICIENCY SEER
 TOTAL CAPACITY* MBH [kW]
 SENSIBLE CAPACITY* MBH [kW]
 OUTDOOR DESIGN TEMP °F [°C] DB
 TEMP. OF AIR ENTERING
 EVAPORATOR COIL °F [°C] DB
 °F [°C] WB
 POWER INPUT REQUIREMENT kW
 (*uses blower motor heat)

HEATING PERFORMANCE

EFFICIENCY HSPF
 TOTAL CAPACITY* MBH [kW]
 OUTDOOR DESIGN TEMP °F [°C] DB
 TEMP. OF AIR ENTERING
 EVAPORATOR COIL °F [°C] DB

SUPPLY AIR BLOWER PERFORMANCE

TOTAL AIR SUPPLY CFM [L/s]
 TOTAL RESISTANCE EXTERNAL
 TO UNIT IWG
 BLOWER SPEED RPM
 POWER OUTPUT REQUIREMENT BHP
 MOTOR RATING HP [W]
 POWER INPUT REQUIREMENT kW

ELECTRICAL DATA

POWER SUPPLY Hz
 TOTAL UNIT AMPACITY AMPS
 MINIMUM WIRE SIZE AWG
 MAXIMUM OVERCURRENT DEVICE
 FUSES/HACR BREAKER AMPS

CLEARANCES

ACCESS SIDE 24" [609.6 mm]
 AIR INLETS 12" [304.8 mm]
 ABOVE UNIT 60" [1524 mm]

FEATURES FOR SA16 AIR CONDITIONER UNITS

- New composite base pan – dampens sound, captures wire grille, eliminates corrosion and reduces number of fasteners needed
- Powder coat paint finish – for a long lasting professional finish
- Scroll compressor – uses 70% fewer moving parts for higher efficiency and increased reliability
- Modern cabinet aesthetics – increased curb appeal with visually appealing design
- Wire grille – provide ultimate coil protection, enhance cabinet strength, and increased cabinet rigidity
- Optimized fan orifice – optimizes airflow and reduces unit sound
- Rust resistant screws – confirmed through 1500-hour salt spray testing
- 3"-4"-5" service valve space – provides a minimum working area of 27-square inches for easier access
- 15" wide, industry leading corner service access – makes repairs easier and faster.
- External gauge port access – allows easy connection of "low-loss" gauge ports
- Single-row condenser coil – makes unit lighter and allows thorough coil cleaning to maintain "out of the box" performance
- Fewer cabinet fasteners – allow for faster access to internal components and hassle-free panel removal
- Service trays – hold fasteners or caps during service calls
- QR code – provides technical information on demand for faster service calls
- Fan motor harness with extra long wires allows unit top to be removed without disconnecting fan wire.

ACCESSORIES/OPTIONS

- Compressor Crankcase Heater
 Low Ambient Control (Model No. RXAD-A08)
 Compressor Sound Cover
 Compressor Hard Start Kit
 Low Pressure Control (RXAC-A07)
 High Pressure Control (RXAB-A07)

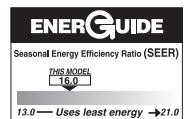

SA16 18, 24, 30,
36, 42, 48, 60

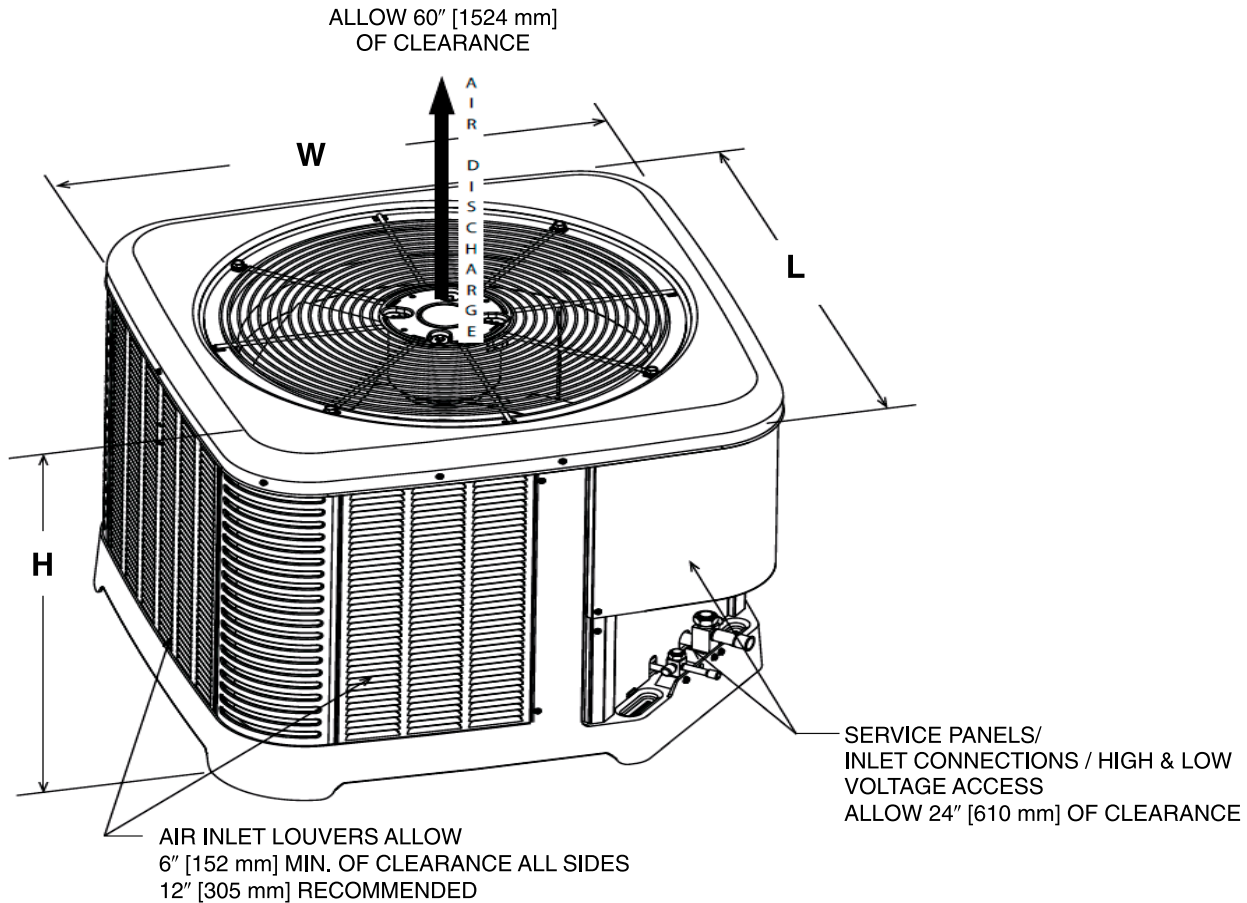

ST-A1226-02-00

Unit Dimensions

MODEL NO.	OPERATING						SHIPPING					
	H (Height)		L (Length)		W (Width)		H (Height)		L (Length)		W (Width)	
	INCHES	mm	INCHES	mm	INCHES	mm	INCHES	mm	INCHES	mm	INCHES	mm
SA1618	27	685	29.75	755	29.75	755	27.375	695	32.25	819	32.25	819
SA1624	27	685	33.75	857	33.75	857	27.375	695	36.25	921	36.25	921
SA1630	27	685	35.75	908	35.75	908	27.375	695	38.25	972	38.25	972
SA1636	31	787	35.75	908	35.75	908	31.375	797	38.25	972	38.25	972
SA1642	39	990	35.75	908	35.75	908	39.375	1000	38.25	972	38.25	972
SA1648	45	1143	35.75	908	35.75	908	45.375	1153	38.25	972	38.25	972
SA1660	51	1295	35.75	908	35.75	908	51.375	1305	38.25	972	38.25	972

[] Designates Metric Conversions

Before proceeding with installation, refer to installation instructions packaged with each model, as well as complying with all Federal, State, Provincial, and Local codes, regulations, and practices.

Sure Comfort® Heating and Cooling
P.O. Box 17010, Fort Smith, AR 72917

"In keeping with its policy of continuous progress and product improvement, Sure Comfort® reserves the right to make changes without notice."