



THE GUIDE FOR
INSTALLING, STARTING-UP,
OPERATING AND MAINTAINING
REFRIGERATION SYSTEMS

TABLE OF CONTENTS

Safety Information and Guidelines	2
Receiving and Handling	2
Locating and Mounting Condensing Units	3
Locating and Mounting Evaporators	4 - 5
Piping	6 - 7
Multiple Evaporator Piping	8
Leak Testing	8
Suction Line Design	9
Equivalent Feet of Tube	10
Weight of Refrigerant in Copper Tube	10
Evacuation	11
Field Wiring	12
Field Wiring Diagram	13 - 15
Charging and Start-Up	16
Charging Flooded Condenser Systems	17
Pressure Control Settings	18
Defrosting Evaporators	19
Product Loading and Air Circulation	20
Evaporator Superheat	20
Compressor Superheat	21
Return Gas and Discharge Line Temperature Settings	21
Scroll Compressor Operation	22
Trouble-Shooting Systems.....	23-24
Water Cooled Condenser Maintenance	25
System Start-Up Check List	26
System Service Check List	27
System Maintenance	28
Ordering Replacement Parts	28

SAFETY INFORMATION

READ THESE INSTRUCTIONS ALL THE WAY THROUGH BEFORE STARTING WORK!

**Make sure all power sources are disconnected before doing any service work
LOCK disconnects in the OFF position to prevent accidental turning on and injury.**

**Commercial refrigeration equipment should be installed, started-up, maintained, and serviced by
trained and certified personnel having experience with this type of equipment.**

**All field wiring must conform to the requirements of the equipment, applicable local codes and the National Electrical
Code. Always use correct size Copper conductors.**

**Sheet metal and coil surface have sharp edges that are a potential injury hazard. Handle carefully,
using gloves and other protective safety wear to prevent injury.**

COMPLY WITH SAFETY AND CAUTION LABELS ON THE EQUIPMENT

THINK SAFETY!

WORK SAFELY!

RECEIVING YOUR EQUIPMENT

INSPECTION

Check all items against the bill of lading to make sure all crates and cartons have been received. If there are any shortages or damage, report it immediately to the carrier and file a freight claim. Damaged equipment is the delivering carrier's responsibility. Take care not to damage equipment when uncrating. Check for concealed damage. Do not return damaged equipment to the factory without prior approval. A Return Material Authorization (RMA) must be obtained in advance.

Items returned without an RMA label will be refused.

Check the unit specplate. Verify that the specplate voltage agrees with the available power supply. Large condensing units, remote condensers, and evaporators should be left on their shipping skid until at their final location. Do not use the shipping skid as a permanent base.

RIGGING and HANDLING

Good rigging and handling practice must be used to protect units from damage. Having proper handling equipment at the jobsite is most important and should be planned in advance. Always use spreader bars when lifting with cable, chain, or slings. Do not hoist a crate from its upper members. If rigging is required, support the crate from the skid. All crates are blocked up for forklift handling. Do not forklift against sheetmetal panels or coils. Always lift against a structural part of the skid or unit at the center of gravity. Secure units to a forklift to prevent slipping off.

Large condensing units have compressors mounted near one end that offsets the center of gravity. Find the center of gravity near the compressor end to prevent tipping when lifting. Smaller, lighter units may be carefully manhandled for short distances. Observe the units for additional lifting and rigging decal's.

LOCATING AND MOUNTING CONDENSING UNITS

Condensing units (CU's) must be located where there is an unrestricted supply of clean, fresh air. Areas with corrosive vapors or materials should be avoided, as should areas with polluted air. Do not locate units where air discharge from one will enter into the air intake of others. Avoid locating units in restricted spaces where heat will build up and can enter the condenser. Condensing units with horizontal airflow should be positioned so that the direction of airflow through the condenser is the same as the prevailing wind. Make sure there is room around the unit for regular inspection and service. Mount all condensing units level.

Roof mounted condensing units must have adequate support for their operating weight plus a safety factor. They should be mounted above supporting walls, over hallways, storage areas, or auxiliary areas that are not sensitive to noise or vibration. Mount them where sound levels are not an important factor.

Pad mounted condensing units should be mounted on smooth and level pads a minimum of 4 inches above ground level. They should be mounted away from windows, doors, and other areas sensitive to noise. The area surrounding a pad mounted unit preferably will be concrete, asphalt, or other smooth, hard, clean level surface. This will keep the condenser coil clean from grass, dirt, and weed clippings. A security fence also helps to keep leaves and other debris out of the coil. Protecting the condensing unit also protects the product stored in the cooler or freezer!

Condensing units, piping and disconnects should not be accessible to unauthorized persons. To protect the equipment from tampering and vandalism and protect people from accidental injury, a security fence with locked access is highly

recommended. Condensing units accessible to the general public often receive damage to the coil, piping, fans, or other components. Protect your equipment, your products in storage, and protect yourself from liability. Prevent accidents and loss.

Condensing units must be mounted to pads or structural rails with adequate size bolts to prevent the unit from shifting or changing position. Mounting holes are provided for proper size fasteners. Iso-pads are recommended to absorb vibration and reduce noise. Seismic isolator may be required in some localities. Follow the isolator manufacturers recommendation when selecting and applying isolators. Mount units level.

Condensing units with spring mounted compressors are shipped with blocks or retainers under the compressor feet to keep it from shaking during shipment. On Copeland H and K model compressors, remove the blocks and loosen the mounting nut to have 1/16 inch between the nut and rubber spacer. On 3 HP and larger models, mounting nuts must be removed to insert the rubber spacer. Remove the blocks, insert the rubber spacer over the mounting stud, replace the nuts and tighten to 1/16 inch from the spacer. Do not tighten mounting nuts tight against the rubber spacer or foot. Units with iso-pad mounted compressors are shipped with the mounting nuts tight and they should be checked to be sure they have not loosened in shipment.

Observe minimum clearances commendations below. Do not locate any unit to be bordered by tall walls or obstructions on three or more sides, even when the clearance are observed. The minimum space between units is 2 x dimensions shown.

Table 1

CONDENSING UNIT DESCRIPTION		MINIMUM DIMENSION (Inches)^		
		A	B	C
Small CU's*	1/2 thru 2 HP	60	24	36
	3 thru 6 HP	72	24	36
Medium CU's*	3 thru 22 HP	72	30	48
Large CU's**	20 thru 80 HP	48	48	48

* Horizontal air discharge

** Vertical air discharge

^ Always observe NEC electrical clearances

Drawing 1

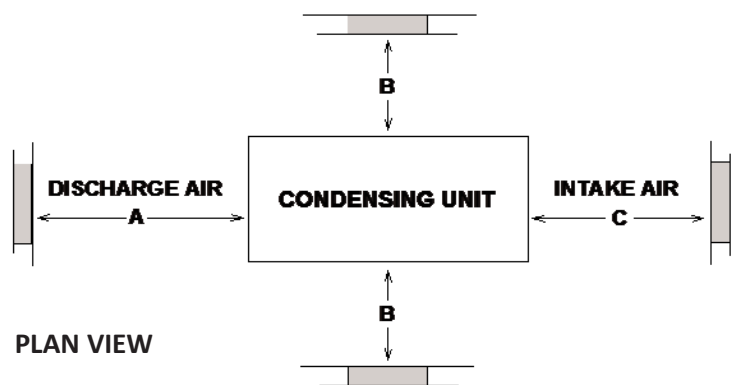

LOCATING WALK-IN EVAPORATORS
MINIMUM DIMENSION FOR GOOD AIR CIRCULATION
AND EVAPORATOR PERFORMANCE

Table 2

EVAPORATOR HEIGHT (Key Dim.) H	Unit to Back Wall * 1 x H	Unit to Side Wall 1 x H	Unit to Unit 2 x H	Unit to Front Wall 5 x H	Unit to Floor 3 x H
12"	12"	12"	24"	60"	60" †
15"	15"	15"	30"	75"	60" †
18"	18"	18"	36"	90"	60" †
24"	24"	24"	48"	120"	72"
30"	30"	30"	60"	150"	90"
36"	36"	36"	72"	180"	108"
42"	42"	42"	84"	210"	126"
48"	48"	48"	96"	240"	144"

* Critical Minimum Dimension

H = Height of Evaporator

† - Minimum Walk-in Height of 7'-0"

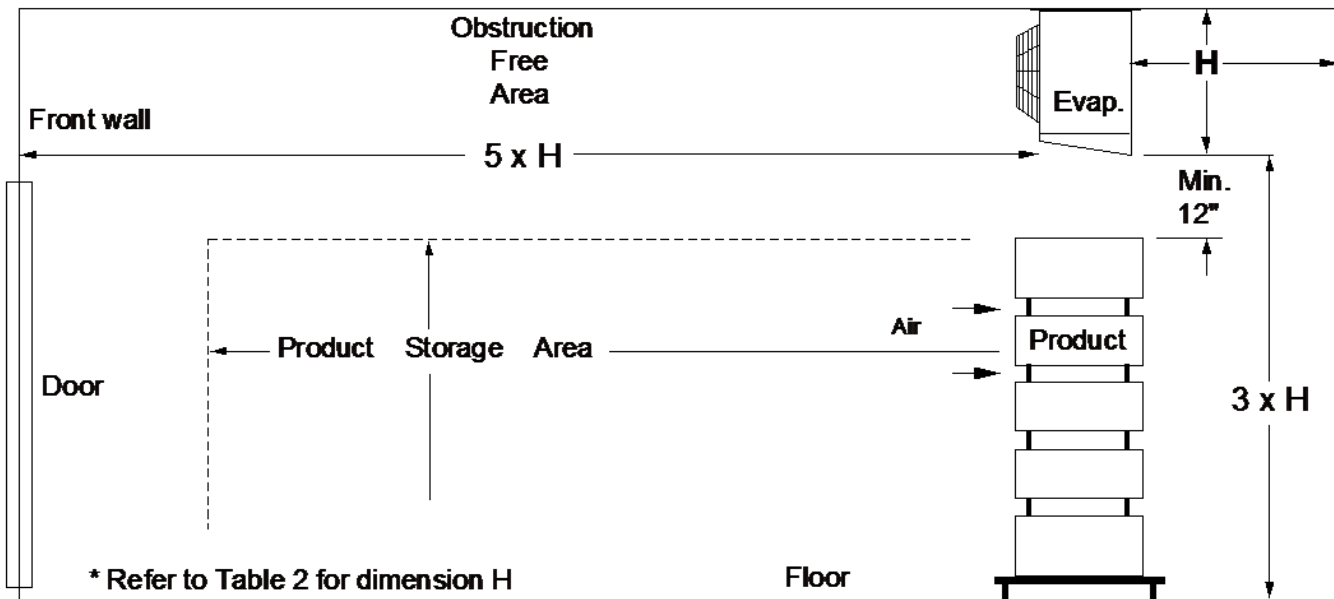

Drawings are not to scale.

SIDE VIEW

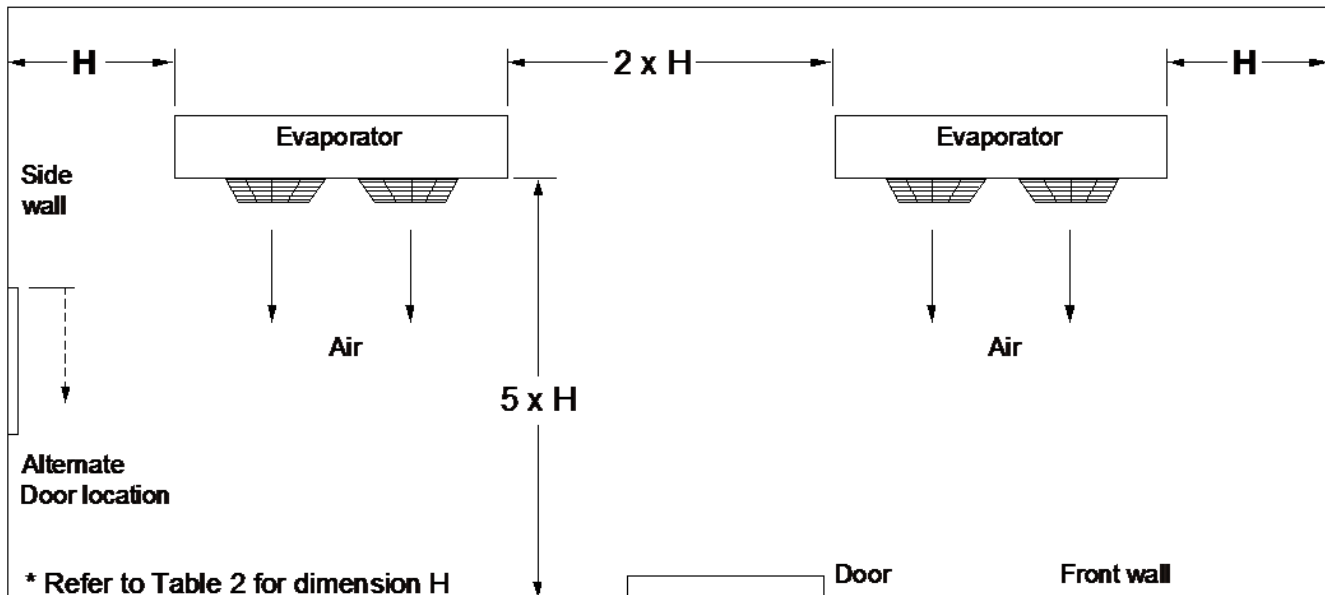

TOP VIEW

LOCATING AND MOUNTING WALK-IN EVAPORATORS

Locate evaporators for the air pattern to cover all of the room. Do not restrict the inlet or outlet air stream. Avoid placing evaporators above or close to doors. Direct the air stream toward the door when possible or arrange to blow down an aisle. Allow sufficient clearance for air circulation and servicing the unit. The ceiling structure must have adequate strength to support all mechanical equipment, components, piping, and personnel. Heavy Zinc plated or stainless steel bolts should be

used to mount evaporators. We recommend a minimum 5/16" diameter for Low Profile, Low Velocity and Dual Air Discharge units. A minimum 3/8" diameter should be used with Medium Profile and High Profile Warehouse units. Use flat washers next to hanger bars and tighten all fasteners securely. Hang all unit coolers level to insure positive condensate draining. All drain lines must be trapped.

Drawing 4

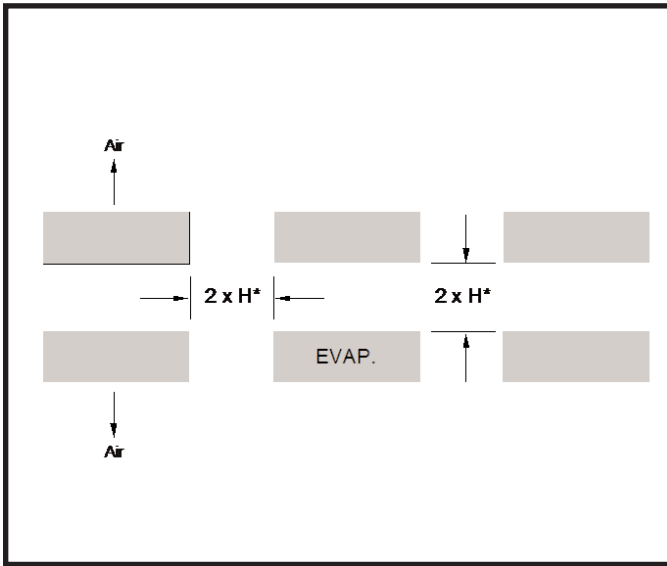

TOP VIEW - Large coolers or freezers where one wall will not accommodate all evaporators or desired air throw is excessive.

Drawing 5

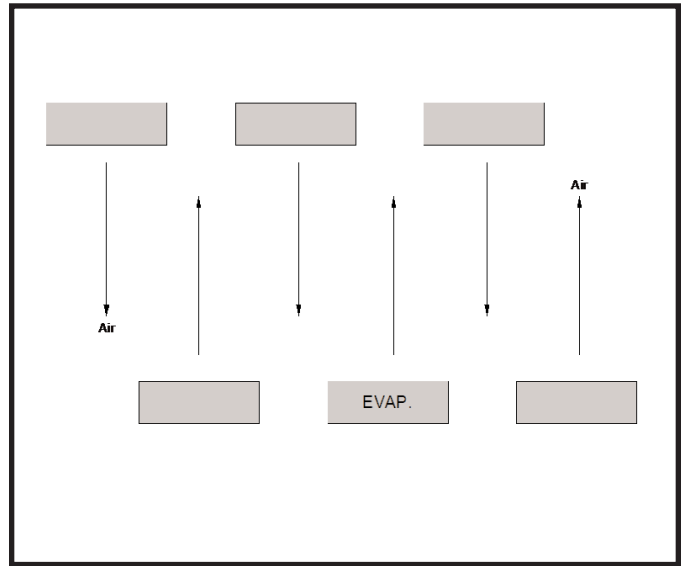

Drawing 6

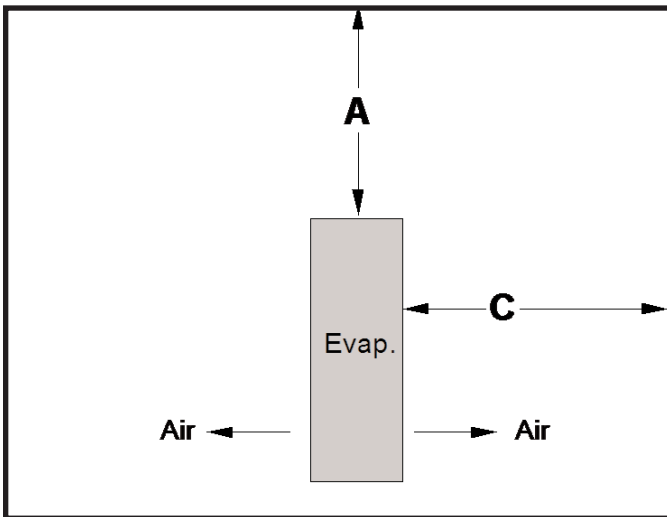

TOP VIEW - Single Center mount Unit

Drawing 7

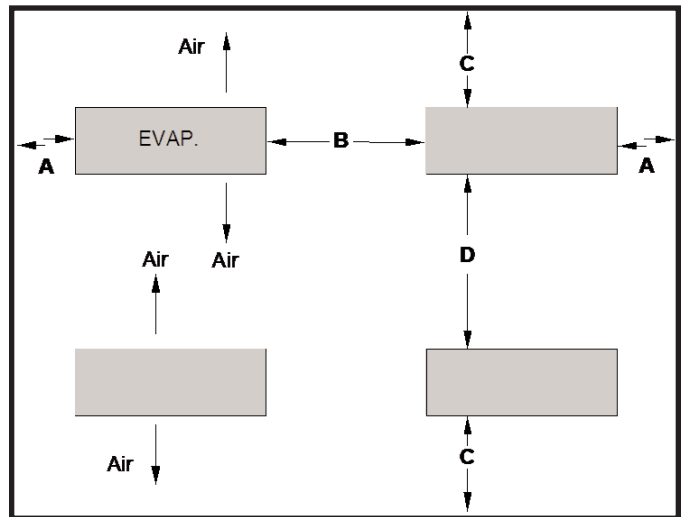

TOP VIEW - Multiple Center mount Unit

Table 3

RECOMMENDED SPACING FOR CENTERMOUNT EVAPORATORS

A		B		C		D	
Min.	Max.	Min.	Max.	Min.	Max.	Min.	Max.
1'	8'	2'	16'	3'	12'	8'	24'

Dimensions are in feet. One foot minimum between bottom of unit and top of product.

PIPING

Condensing Unit and Evaporator coils are thoroughly cleaned and dehydrated at the factory. Care must be taken when field piping to prevent foreign materials and moisture from entering the system. Do not leave units or piping open to the atmosphere any longer than necessary. Use ACR grade Copper tube, keeping it dry, clean, and capped. If type "L" tube is used, it should be thoroughly cleaned internally. When brazing, always pass dry nitrogen through the tubing to prevent oxide and scale from forming. A suitable silver alloy solder should be used on suction and liquid lines. Use only wrought Copper fittings. Long radius elbows should be used. Install all piping and components in accordance with local and national codes and in conformance with good refrigeration practice for proper operation of the systems.

The suction line and its components must be selected and installed with extreme care. The suction line must be sized for high enough refrigeration velocity to assure good oil return, and low enough pressure drop to prevent excessive system capacity loss. The optimum line size for a system will result in a reasonable line size for a system will result in a reasonable velocity at minimum pressure drop. Total suction line pressure loss should not exceed 2°F equivalent loss.

Suction lines risers must be carefully selected, have an oil trap at the bottom and at 15 foot intervals up the riser. The should be the same size as the vertical riser connected to its outlet. Riser should not be larger in diameter than horizontal runs.

Horizontal runs of suction line should slope 1 inch per 10 feet in the direction of flow. A 1/4 inch male flare schrader fitting should be installed in the suction line at the evaporator outlet to obtain accurate evaporator pressure and superheat readings.

Liquid lines, both horizontal and vertical, are normally the same size. In vertical lines with upward flow there will be a pressure loss similar to that in water line riser, due to the lift involved. If ignored, this pressure loss can result in liquid line flash gas that will prevent good expansion valve and system performance. Sizing the liquid line too small will also result in flash gas. Sizing a liquid line larger than necessary will increase the system refrigerant charge. Flash gas can be avoided by adding subcooling to the system, however, subcooling should not be considered as an acceptable alternative to properly sized liquid lines.

One method to obtain liquid subcooling and return gas superheat is to join the liquid and suction line together and then insulate them. This economical method is often used on vertical lines. Another alternative is to use a manufactured liquid-suction heat exchanger. This type of heat exchanger is usually located inside the cooler or freezer, near the evaporator. Most HTPG Air Cooled Condensing Units include an integral liquid subcooling circuit in the condenser coil. Any one of these methods will normally provide enough subcooling to offset the liquid line pressure loss due to friction and lift. Liquid lines with more than 30 feet of vertical lift need special attention!

A liquid line solenoid should be installed near the expansion valve inlet. If there are multiple evaporators, locate the solenoid near the branch line to the first evaporator.

Before installing the expansion valve on the distributor, check the distributor to be sure it has a nozzle installed or is a venturi type. For optimum performance, the expansion valve outlet should be installed directly to the distributor. If reducing couplings or adapters are required keep them close coupled. Do not have elbows between the expansion valve and distributor. The expansion valve must be selected to match the system capacity. Follow the expansion valve manufacturers ratings when selecting the valve and use the appropriate capacity multiplier if liquid is subcooled below 70°F. If the amount of liquid subcooling may vary, a balanced port expansion valve should be used.

Evaporators with 1/2 inch flare nut (FN) inlet distributors can be converted to a sweat type inlet. All distributors have room to remove the flare with a mini-cutter. The inlet would be 1/2 inch OD and an expansion valve with 1/2" ODF outlet would fit. Sporlan type EG, SBF, or S expansion valves are available with 1/2" ODF extended Copper outlet connections. To protect the valve(s), wrap them with a wet rag while brazing. Disassembly of the valve is not required.

PIPING

Expansion valves are supplied with clamps for securing the bulb to the suction line. The bulb must be secured at the evaporator outlet, on the side of a horizontal run of suction line, at the 4 o'clock or 8 o'clock position, before any traps. The bulb must be in uniform contact with clean Copper tube and must not bridge any fitting or uneven surface. A thermal mastic or heat transfer compound may be used with the expansion valve bulb and suction line for quicker expansion valve response. **DO NOT OVERTIGHTEN BULB CLAMPS OR DEFORM THE BULB IN ANY WAY.**

Drain lines should be the size of the evaporator drain pan connection or larger. They should not be reduced in size. Plastic drain lines are often used in coolers, however, Copper or metal lines are recommended if room temperature is below 35°F. All drain lines must be protected from freezing. All drain lines must be trapped and run to an open drain. Drain lines should be sloped 4 inches per foot to insure positive drainage. Never connect a condensate drain directly to a sewer line. Never drain onto a floor or walkway, creating a safety hazard. Traps must be in warm ambient or be protected from freezing. It may be necessary to run heat tape the entire length of the drain line and trap to prevent freezing. Insulating the drain line is recommended with the heat tape energized continuously. Drain properly and safely!

All piping must be adequately supported to prevent vibration and breaking. Tube clamps should have a gasketed surface to prevent abrasion. Inspect all piping while the equipment is operating and add supports to prevent stress and vibration. When the liquid solenoid opens and closes, the liquid line will tend to move forcefully. Without proper support the joints at the liquid solenoid, expansion valve, distributor, and distributor

leads can fracture. Take care to secure the liquid line at the evaporator. Line supports are inexpensive compared to downtime and refrigerant loss. All piping must be protected where it passes through walls or ceilings. Precautions should be taken to see that the piping does not touch any structural members and is properly supported in order to prevent the transmission of vibration into the building. The piping chase must be thoroughly sealed to protect the tube and prevent ambient air from entering the refrigerated space. Seal around the drain line where it passes through the wall. Air leaks can cause equipment problems, damage the structure and product, increase load, increase operating cost, and can cause a safety hazard. Eliminate all air leaks. See Table 11 for recommended line support spacing.

In low temperature application, or where proper oil circulation cannot be maintained, an oil separator may be required. When operating at evaporator temperatures of -20°F and lower, oil separators should be considered in order to minimize the amount of oil in circulation.

In addition to the critical nature of oil return, there is no better invitation to system difficulties than an excessive refrigerant charge. A reasonable pressure drop is far more preferable than oversized lines which can contain refrigerant far in excess of the systems needs. On systems with a larger refrigerant charge, or on systems where liquid floodback is likely to occur, a suction line accumulator is strongly recommended.

LEAK TESTING

After all refrigerant connections are made, have been visually inspected and secured, add proper system refrigerant until the pressure is 25 to 35 PSI. Then pressurize with dry nitrogen up to 120 to 140 PSI. Always use a pressure reducing regulator. Wait 20 to 30 minutes for the refrigerant to reach all parts of the system. Using an electronic leak detector, check all connections and components, both factory and field installed. The compressor, evaporator coil, and condenser coil must be checked. Valves and controls must be checked. Repair any leaks found and re-check until no leaks are located and the pressure holds steady. Leave the system pressurized overnight to verify that the pressure remains unchanged.

Unlocated leaks can mean unprofitable call back, additional refrigerant cost, higher energy cost, and possible internal contamination and failure of the system. With highly hygroscopic polyol ester (POE) lubricants, leak detection is essential to prevent moisture from entering a system. The system installation must be leak free!

After leak testing has been completed, the system must be thoroughly evacuated before charging.

SUCTION LINE DESIGN

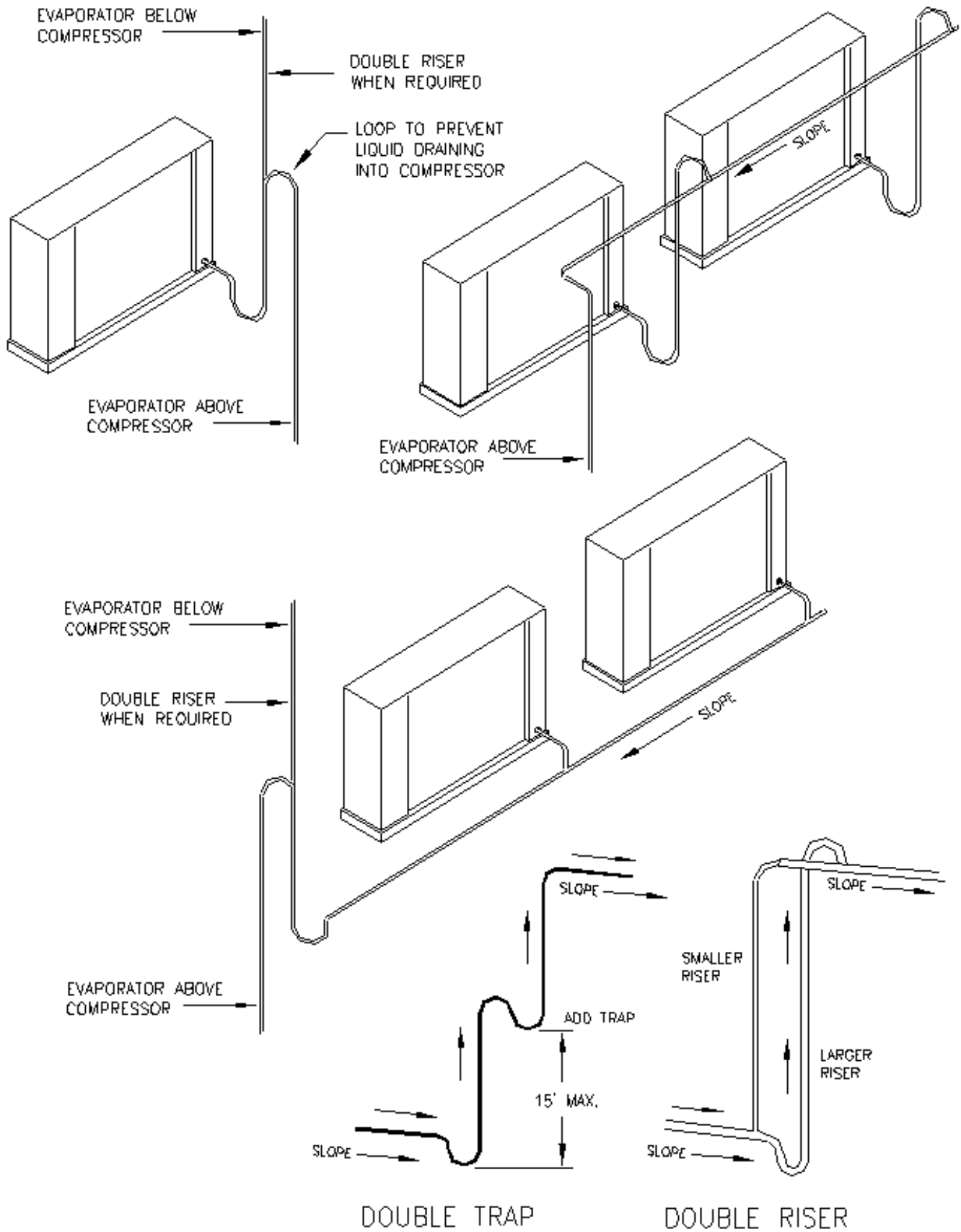

ESTIMATING EQUIVALENT FEET OF TUBE DUE TO FRICTION

Table 4

COMPONENT DESCRIPTION	LINE SIZE - inches O.D. - TYPE "L" COPPER TUBE										
	1/2	5/8	7/8	1-1/8	1-3/8	1-5/8	2-1/8	2-5/8	3-1/8	3-5/8	4-1/8
Long radius "L" or straight thru "T"	1	2	2	2	3	3	4	5	6	7	8
90° turn "T"	3	3	4	5	7	8	10	12	15	18	21
Smooth (1 size) reducer	2	2	3	3	4	5	6	7	8	9	10
Trap	4	5	6	7	8	10	13	16	19	24	25
Globe valve (open)	15	17	21	28	38	44	54	68	82	98	—
Angle valve (open)	6	8	10	13	17	20	25	30	38	45	—
Ball valve (full flow, open)	1	1	1	2	2	2	3	3	4	4	—
Check valve (ball type)	6	8	10	12	14	16	20	25	30	35	—
Solenoid valve*	5	5	5	5	5	—	—	—	—	—	—
Sight glass *	3	3	3	3	3	—	—	—	—	—	—
Filter/Drier	4	4	4	4	4	—	—	—	—	—	—

* - When sized per manufacturers catalog for minimum recommended line loss.

**Quick Estimating Equivalent Length when only straight length of tube required is known:
Straight Line Length x 1.5 = Estimated Equivalent Length**

REFRIGERANT CHARGE PER 100 FEET OF LINE

Table 5

Refrigerant	Line Size	Liquid	Discharge Gas	Suction Gas				
				-40°F	-20°F	0°F	20°F	40°F
R407A	3/8	5.3	0.8	0.0	0.0	0.1	0.1	0.1
	1/2	9.4	1.4	0.0	0.1	0.1	0.2	0.2
	5/8	14.8	2.3	0.1	0.1	0.2	0.2	0.3
	7/8	28.9	4.4	0.1	0.2	0.3	0.5	0.7
	1 1/8	47.8	7.3	0.2	0.3	0.5	0.8	1.1
	1 5/8	99.8	15.3	0.4	0.7	1.1	1.6	2.3
	2 1/8	170.7	26.1	0.7	1.2	1.8	2.7	4.0
	2 5/8	260.5	39.8	1.1	1.8	2.8	4.2	6.1
	3 1/8	-	56.4	1.5	2.5	3.9	5.9	8.7
4 1/8	-	98.3	2.6	4.4	6.8	10.3	15.1	
R448/449A	3/8	5.1	0.7	0.0	0.0	0.1	0.1	0.1
	1/2	9.0	1.3	0.0	0.1	0.1	0.1	0.2
	5/8	14.1	1.0	0.1	0.1	0.2	0.2	0.3
	7/8	27.6	3.9	0.1	0.2	0.3	0.5	0.7
	1 1/8	45.6	6.4	0.2	0.3	0.5	0.8	1.1
	1 5/8	95.2	13.4	0.4	0.7	1.1	1.6	2.3
	2 1/8	162.8	22.9	0.7	1.2	1.8		3.9
	2 5/8	248.4	34.0	1.1	1.8	2.8	4.1	6.0
	3 1/8	-	49.6	1.5	2.5	3.9	5.9	8.5
4 1/8	-	86.4	2.7	4.4	6.8	10.2	14.8	

EVACUATION

Proper installation procedures must include **DEEP EVACUATION** of the system. It takes both a deep vacuum and filter-drier in a system for proper protection. The filter-drier will pick up moisture, oxides, fibers, particles of metal, flux, and other materials that evacuation cannot remove. **Removing the AIR and MOISTURE from a system by applying a DEEP VACUUM is an absolute necessity.**

Only by using a rotary deep vacuum pump and an electronic deep vacuum gauge can the installer be sure a system is dehydrated sufficiently to prevent early breakdown. By using a rotary deep vacuum pump and the multiple evacuation method, an electronic deep vacuum gauge can indicate that the system has been adequately evacuated and if a leak exists. The installer must comply with government regulations and use appropriate procedures and equipment to avoid releasing refrigerants into the atmosphere.

A two-valve test manifold mounted on the vacuum pump is recommended. To shorten the evacuation time and to prevent erroneous gauge readings, install the largest diameter vacuum line feasible and as short as practical. A minimum 3/8 inch OD Cooper tube or seamless metal hose is recommended. The larger the system, the larger the vacuum line diameter should be. Do not use neoprene hose for evacuation. Neoprene hose is not sufficiently vacuum tight for evacuation or testing. Using a deep vacuum sealant on all line connections and fittings is good practice.

Be prepared to frequently change the vacuum pump oil. Use oil that is specifically refined for rotary deep vacuum pumps. A vacuum pump cannot create a vacuum less than the vapor pressure of its sealing oil. Clean and dry deep vacuum oil is essential for proper system evacuation and protection of the vacuum pump. If the vacuum pump cannot quickly pull down to a low blank-off vacuum reading the oil must be changed. If the pump and oil are in good condition it should quickly attain a 100 micron reading when blanked-off. We recommend checking the pump condition with this test before attempting to evacuate a refrigeration system.

Use an electronic deep vacuum gauge. The system must hold 400 microns or less on POE systems after final evacuation. The vacuum gauge should hold very close to this reading for 10 minutes after the pump is closed off. Holding steady at or close to this micron reading indicates the system is dry and leak free. The compressor service valves must be open for the final evacuation so that the compressor and entire system is evacuated.

Pull a continuous vacuum for a minimum of 4 hours. Longer is better. On systems over 5 horsepower pull the vacuum overnight. POE lubricants are much slower than mineral oils to release moisture. Proper evacuation of systems with POE lubricants can take more time. The vacuum decay test for 10 minutes described in paragraph 5 is strongly recommended. **Deep evacuation is an absolute necessity!**

Make the charging line connection with a line purged of air & break the vacuum. Break the vacuum with the proper system refrigerant and pressurize the system to 5 to 10 PSI before removing the vacuum pump lines. **DO NOT START THE COMPRESSOR WHILE THE SYSTEM IS UNDER VACUUM.** Do not use the compressor as a vacuum pump.

EVACUATION RECORD

System ID _____ HP _____

Start Vacuum: _____ AM/PM Date ____-____-____

_____ microns after 4 hours

_____ microns after 8 hours

_____ microns after 12 hours

_____ microns after 16 hours

Stop Vacuum: _____ AM/PM Date ____-____-____

_____ microns after _____ hours of evacuation

_____ microns 10 minutes after pump shut off

Evacuated by _____

FIELD WIRING

All field wiring must be in compliance with local and national codes. Use only Copper conductors of the appropriate size. The equipment specplates are marked with the electrical characteristics. All field wiring should enter the equipment control panels through bushing.

Disconnect switches and evaporator branch circuit protection are supplied by the installer and must comply with the governing electrical codes.

Be sure the power is disconnected and tighten all connections before starting equipment. If any electrical components are located outdoor, use the appropriate outdoor fixture, fittings, and conduit.

System wiring diagrams are located inside the condensing unit control panel door. Wire components as shown on the wiring diagrams. All equipment must be grounded. To aid the evacuation and provide additional compressor protection during charging and start-up, the crankcase heater should be energized 24 hours before charging begins. After start-up, any vibrating armored cable should be secured and must not contact refrigerant tubing.

The room thermostat and liquid line solenoid should be wired in series per the diagrams. The pumpdown cycle is mandatory to maintain compressor warranty. Carefully follow the diagrams of multiple evaporator systems to ensure proper defrosting of all units.

TYPICAL FIELD WIRING

OFF-CYCLE AIR DEFROST WITH OR WITHOUT TIMER

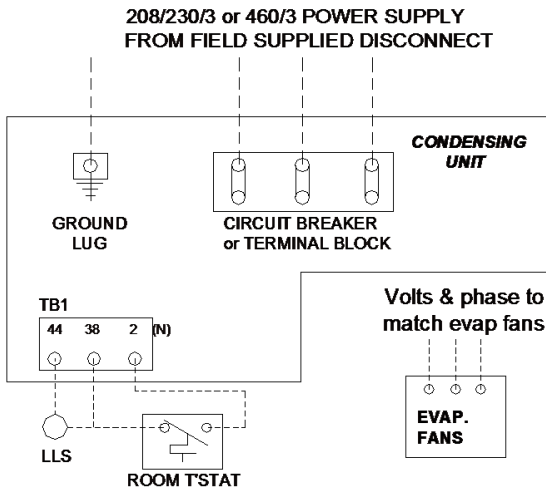

ALTERNATE UNIT COOLER WIRING AIR DEFROST WITHOUT TIMER

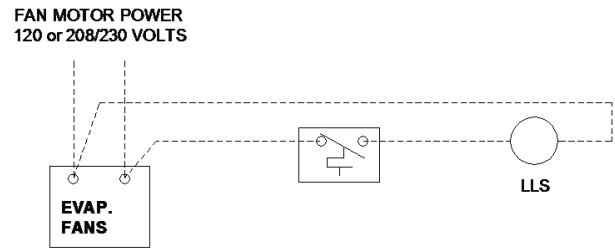

ALL UNITS MUST BE GROUNDED

For factory wiring refer to the diagram in the unit.

If liquid line solenoid (LLS) is factory mounted or if unit has low ambient flooded condenser option, connection to TB1 - 38 terminal **must** be made.

ELECTRIC DEFROST, 1Ø FANS & HEATERS

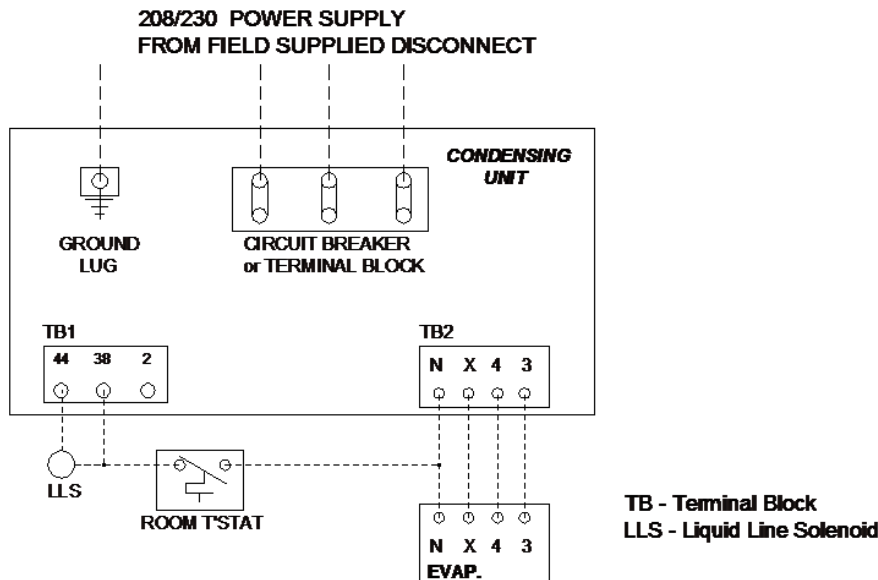

TYPICAL FIELD WIRING

ELECTRIC DEFROST, 1Ø FANS & 3Ø HEATERS

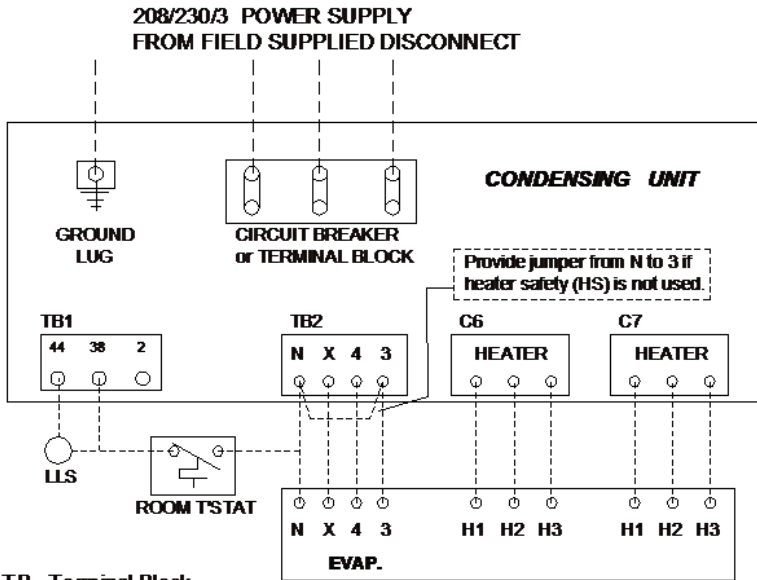

TB - Terminal Block
 C# - Contactor #
 LLS - Liquid Line Solenoid
 H - Heater terminal

ALL UNITS MUST BE GROUNDED

For factory wiring refer to the diagram in the unit.

If liquid line solenoid (LLS) is factory mounted or if unit has low ambient flooded condenser option, connection to TB1 - 38 terminal **must** be made.

ELECTRIC DEFROST, MULTIPLE EVAPORATOR, 1Ø FANS & 1Ø HEATERS

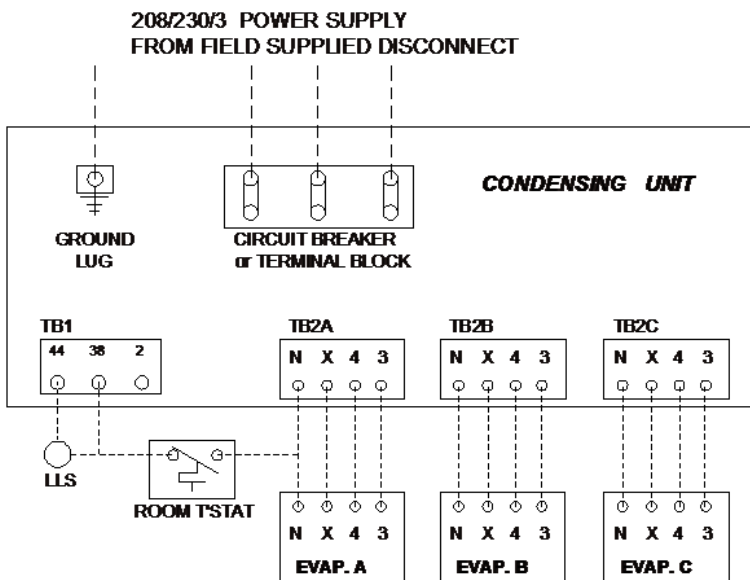

TB - Terminal Block
 LLS - Liquid Line Solenoid

ALL UNITS MUST BE GROUNDED

For factory wiring refer to the diagram in the unit.

If liquid line solenoid (LLS) is factory mounted or if unit has low ambient flooded condenser option, connection to TB1 - 38 terminal **must** be made.

THE MOST POSITIVE AND DEPENDABLE MEANS OF KEEPING LIQUID REFRIGERANT
 OUT OF THE COMPRESSOR CRANKCASE IS THE USE OF A PUMPDOWN CYCLE

TYPICAL FIELD WIRING

ELECTRIC DEFROST, MULTIPLE EVAPORATOR, 1Ø FANS & 3Ø HEATERS

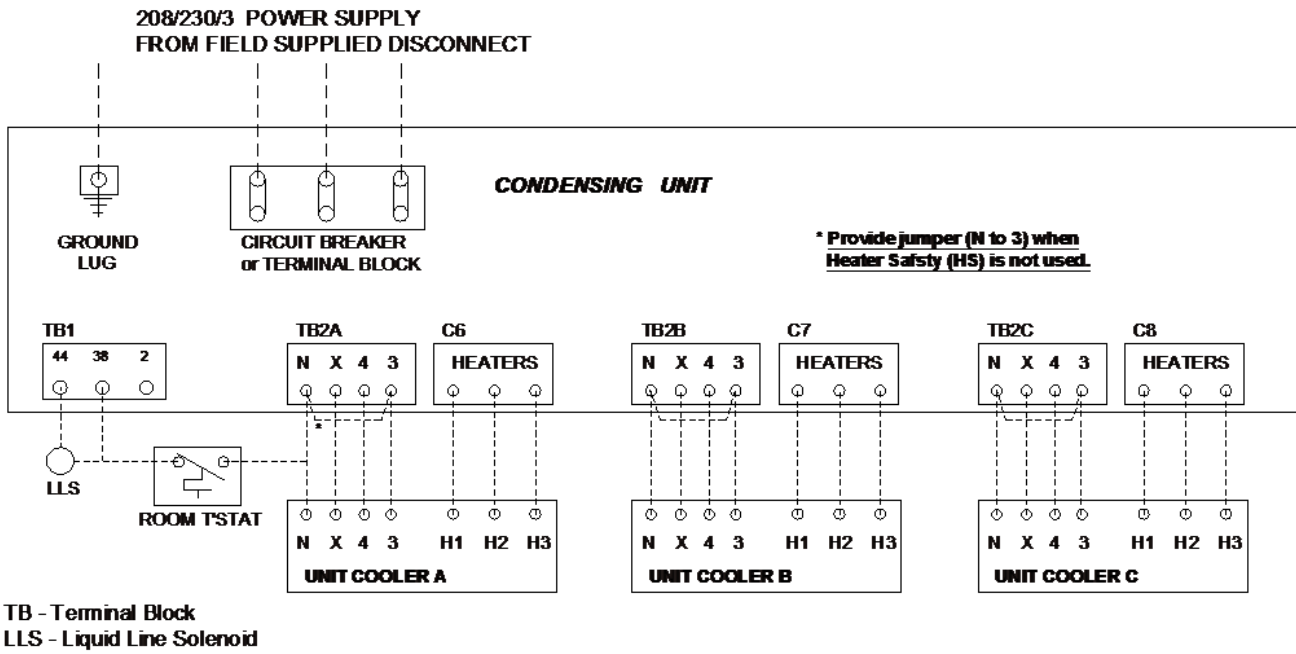

ELECTRIC DEFROST, MULTIPLE EVAPORATOR, 3Ø FANS & 3Ø HEATERS

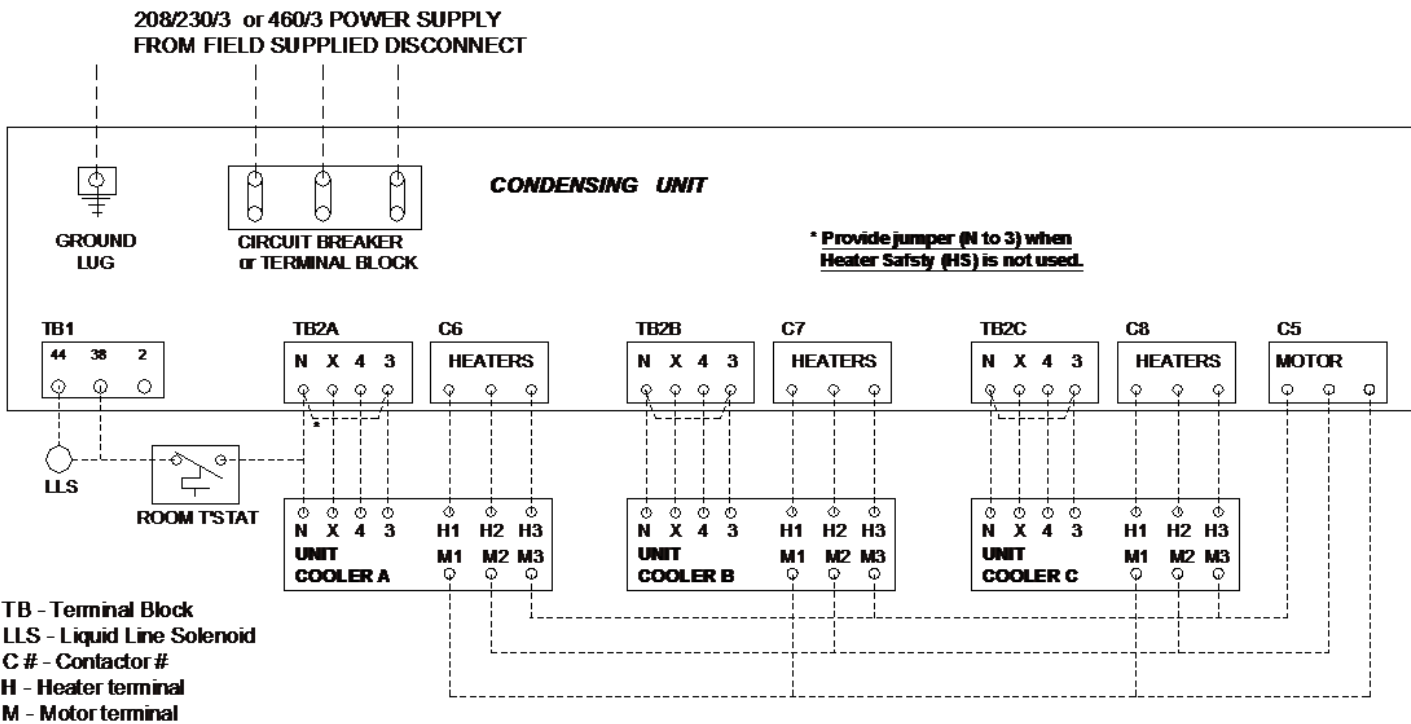

For factory wiring refer to the diagram in the unit. If liquid line solenoid (LLS) is factory mounted or if condensing unit has low ambient flooded condenser option, connection to TB1 - 38 terminal *must* be made.

TYPICAL FIELD WIRING

HOT GAS DEFROST, 1Ø FANS

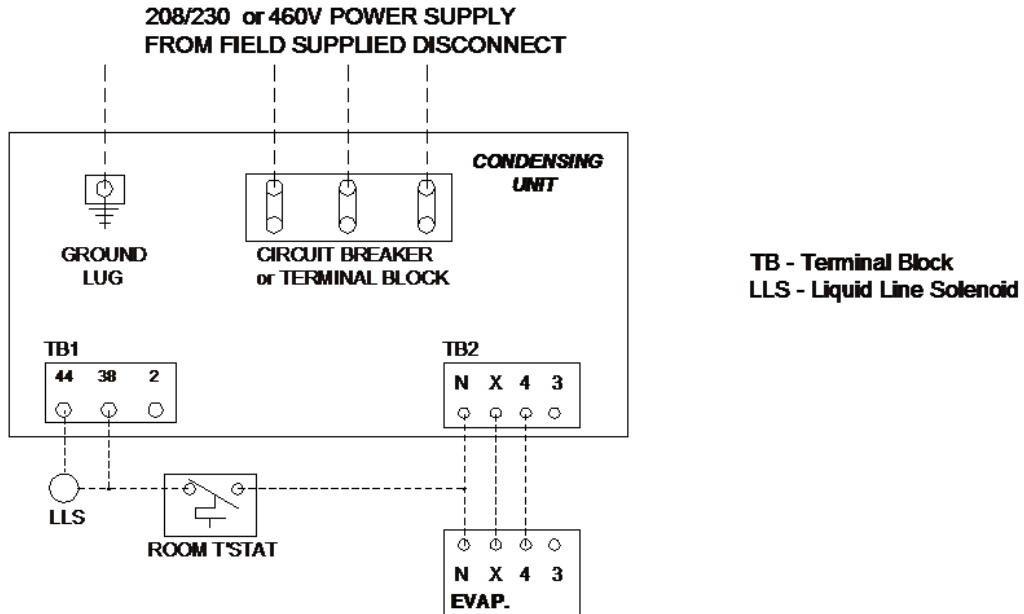

HOT GAS DEFROST, MULTIPLE EVAPORATOR, 1Ø FANS

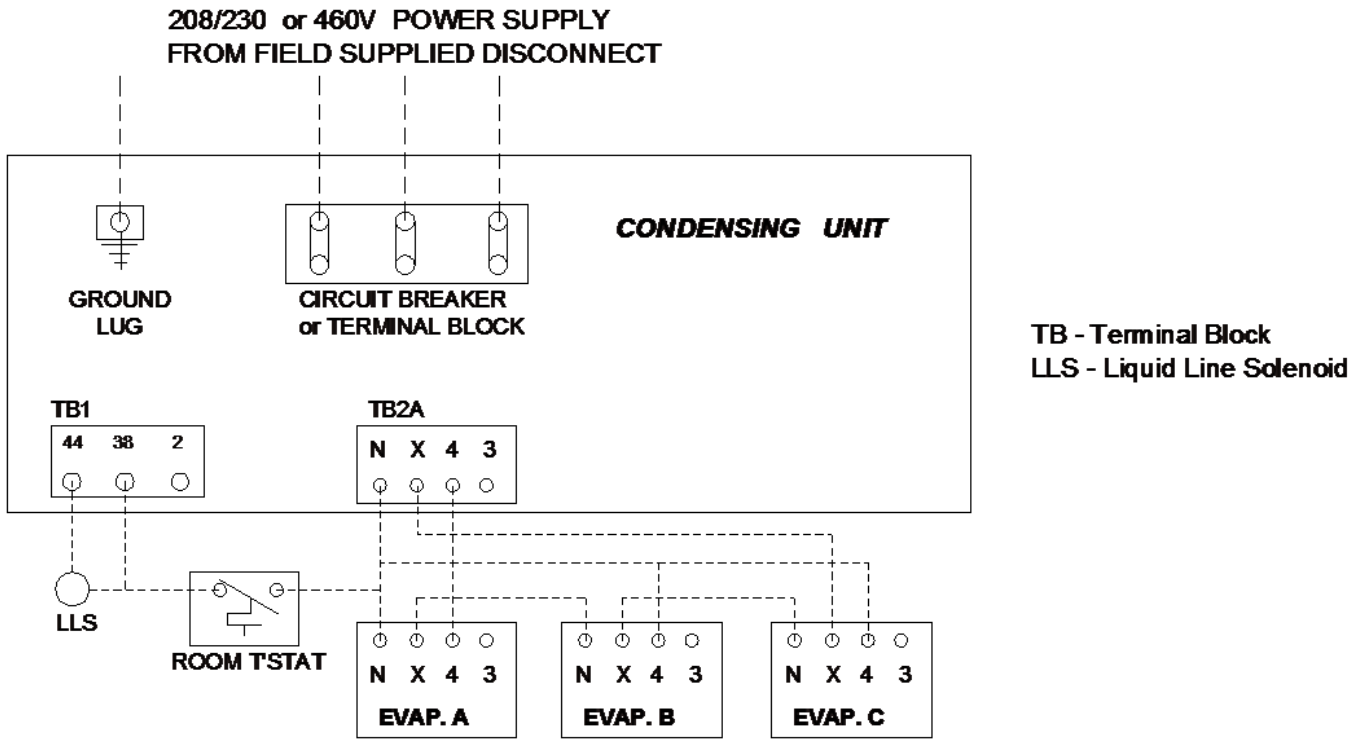

For factory wiring refer to the diagram in the unit. If liquid line solenoid (LLS) is factory mounted or if condensing unit has low ambient flooded condenser option, connection to TB1 - 38 terminal **must** be made.

CHARGING and START-UP

The control circuit should be energized 24 hours before charging and start-up to open the liquid line solenoid and turn on the crankcase heater. This will assist the evacuation and dehydration process and provide additional compressor protection during the charging and start-up.

Charge refrigerant into a system through a filter-drier in the charging line. This provides further assurance the refrigerant charge is clean and dry. The system refrigerant capacity is approximately 80% of the condenser, receiver, and liquid line capacity. If the condenser volume or refrigerant capacity is unknown, the system refrigerant capacity is often calculated at 90% of the receiver and liquid line capacity. Be cautious if the calculated charge is exceeded. Weigh the refrigerant. The actual refrigerant charge should be less than the calculated capacity. **DO NOT charge liquid refrigerant into the suction side of the compressor.**

Be sure the compressor discharge valve is open. the suction valve should be open 2 to 3 turns, with a valve stem wrench attached for quick throttle adjusting. High and low pressure gauges should be attached. Liquid charging is faster. If refrigerant blend (R407A, R404A, or R448A/449A) is used, liquid charging is mandatory. Blend refrigerant cylinders have a dip tube and liquid is charged with the cylinder upright. Break the final vacuum by charging liquid refrigerant into the receiver outlet valve access or the area of liquid line downstream from the receiver outlet.

Approximately 50 to 60% of the system charge can usually be injected into the receiver area before it is necessary to start the compressor for the system to accept more refrigerant. It may be necessary to throttle the compressor suction valve to keep suction pressures reasonable and prevent tripouts during charging and pull-down. If it is necessary to add liquid refrigerant to the suction side, a full control ball valve must be used in the charging line to slowly meter refrigerant vapor into the system.

If the condensing temperature is equal to or greater to temperature shown in table, charge the system until the sight glass just clears, being careful not to overcharge. If the condensing temperature is below table value, a part of the condenser coil can be blocked to raise the condensing temperature equal to or greater than the table value. Be careful not to block the air blast against the compressor. This procedure satisfies systems with floating head pressure control. Follow the same procedure for systems with low-ambient flooded condenser head pressure control.

At the target condensing temperature, charge until the sight glass just clears. Then accurately weigh in the additional pounds of refrigerant specified in the chart on page 17. This will provide adequate charge for all ambient operation. The actual charge should not exceed the calculated systems capacity. After system charging and room pull-down is complete, test the ability of the system to successfully pump down. Raise the room thermostat setting to close the liquid solenoid. The system must pumpdown and shut off at the low pressure cutout setting. See Table 7.

Unblock the condenser coil and return the room thermostat to the desired setting.

The first two to three hours of operation after start-up is a critical time. Do not just start-up and walk away. Watch for floodback and adjust the expansion valve if necessary. Observe system pressures. Check all fans on the evaporator and condensing unit to be sure they are operational and turning the proper direction. Record the pounds of refrigerant charged into the system. Check the compressor oil level frequently. On low temperature systems the fan delay control may cycle the evaporator fans. To keep the fans on until the room pulls down, it may be necessary to jumper the fan delay control.

Check voltage and amperage at the compressor. Voltage must be within 10% of the specplate rating. Amperage should be approximately equal across all three lines. Check the piping for vibration and add supports if needed. Check electrical conduit for vibration and route to prevent contact with tubing.

Use the Start-Up Check List on page 24 to assist you. Don't forget to remove the fan delay jumper if one was used. Also, fully open the suction valve. After the room has pulled down to design temperature and held for 24 hours, review the system guidelines on page 23 and complete a system service record on page 25.

Condenser Flood Valve and Charging Values		
Model	Flood Valve Setting	Target Condensing Temperature
Legacy Models	210 PSIG (92°F)	105°F
Next-Gen 1/2 to 6 HP	148 PSIG (70°F)	80°F
Next-Gen II 3 to 22 HP	148 PSIG (70°F)	80°F

POUNDS OF ADDITIONAL REFRIGERANT CHARGE TO ADD FOR FLOODED HEAD PRESSURE CONTROLS

Table 6

Next-Gen 1/2 to 6 HP				Legacy Medium CU's 3 to 22 HP		Next-Gen II CU's 3 to 22 HP				Vertical Air Discharge CU's 20 to 80 HP			
Base Model	Lbs. to Add			Model DLD	Lbs. to Add	Base Model	Lbs to Add			Model VLD	Lbs. to Add	Model VLD	Lbs. to Add
	R404A	R407A	R448A/ 449A				R404A	R407A/ C/F	R448A/ R449A				
O130E4S	3.6	4.0	3.8	3L22	9.5	BS03E4S	8.5	9.4	8.9	20H22	58.0	18H22	58.0
O150E4S	3.6	4.0	3.8	3L44	8.2	OS04E4S	8.5	9.4	8.9	20M44	50.0	18M44	50.0
O180E4S	3.6	4.0	3.8	4L22	14.3	OS05E4S	8.5	9.4	8.9	25H22	78.0	23H22	78.0
O200E4S	6.3	7.0	6.6	4L44	12.3	DS04M4S	8.5	9.4	8.9	25M44	67.0	23M44	67.0
O250E4S	6.3	7.0	6.6	5H22	14.3	BS04E4S	8.5	9.4	8.9	27L22	58.0	26H22	98.0
O300E4S	7.9	8.7	8.3	5M44	16.4	OS06E4S	8.5	9.4	8.9	27L44	50.0	26M44	84.0
O350E4S	7.9	8.7	8.3	5L22	14.3	BS05E4S	8.5	9.4	8.9	30H22	98.0	32H22	86.0
O400E4S	7.9	8.7	8.3	5L44	12.3	DS05M4S	8.5	9.4	8.9	30M44	84.0	32M44	74.0
O450E4S	11.9	13.1	12.5	6M44	23.0	OS07E4S	16.0	17.7	16.9	30L22	58.0	42H22	115.0
O500E4S	11.9	13.1	12.5	6L22	14.3	BS06E4S	16.0	17.7	16.9	30L44	50.0	42M44	99.0
O600E4S	11.9	13.1	12.5	6L44	12.3	DS06M4S	16.0	17.7	16.9	35H22	115.0	46L44	74.0
O200L4S	3.6	4.0	3.8	7H22	27.0	OS08E4S	16.0	17.7	16.9	35M44	99.0	52H22	117.0
O250L4S	6.3	7.0	6.6	7M44	23.0	BS07E4S	16.0	17.7	16.9	40H22	144.0	52M44	101.0
O300L4S	6.3	7.0	6.6	8H22	27.0	DS07M4S	16.0	17.7	16.9	40M44	124.0	56L44	99.0
O350L4S	6.3	7.0	6.6	8M44	23.0	OS09E4S	16.0	17.7	16.9	50H22	156.0	62H22	195.0
O400L4S	7.9	8.7	8.3	8L22	27.0	DS08M4S	16.0	17.7	16.9	50M44	134.0	62M44	168.0
O500L4S	7.9	8.7	8.3	8L44	23.0	BS08E4S	16.0	17.7	16.9	60H22	195.0	62L44	124.0
O600L4S	7.9	8.7	8.3	9L22	27.0	OS10E4S	16.0	17.7	16.9	60M44	168.0	72H22	173.0
H055E44	2.1	2.3	2.2	9L44	23.0	DS10M4S	16.0	17.7	16.9	1 - Adder is total system capacity.	72M44	149.0	
H080E44	2.1	2.3	2.2	10H22	44.0	BS10E4S	16.0	17.7	16.9		82H22	231.0	
H090E44	2.1	2.3	2.2	10M44	38.0	OS13E4S	26.3	29.0	27.7		82M44	198.0	
H100E44	2.1	2.3	2.2	10L22	27.0	BS12E4S	26.3	29.0	27.7	PARALLEL			
H125E44	3.6	4.0	3.8	10L44	23.0	DS12M4S	26.3	29.0	27.7	17H22	58.0	51H22	117.0
H150E44	3.6	4.0	3.8	12H22	44.0	OS15E4S	26.3	29.0	27.7	17M44	50.0	51M44	101.0
H200E44	3.6	4.0	3.8	12M44	38.0	DS15M4S	26.3	29.0	27.7	21H22	78.0	54L44	99.0
H250E44	6.3	7.0	6.6	12L22	27.0	BS15E4S	26.3	29.0	27.7	21M44	67.0	61H22	195.0
H300E44	6.3	7.0	6.6	12L44	23.0	DS03L4S	5.7	6.3	6.0	24H22	98.0	61M44	168.0
H325E44	7.9	8.7	8.3	15H22	54.0	BS03L4S	5.7	6.3	6.0	24M44	84.0	61L44	124.0
H100L44	3.6	4.0	3.8	15M44	38.0	DS04L4S	8.5	9.4	8.9	31H22	86.0	71H22	173.0
H150L44	3.6	4.0	3.8	15L22	44.0	BS04L4S	8.5	9.4	8.9	31M44	74.0	71M44	149.0
H200L44	3.6	4.0	3.8	15L44	38.0	DS04L4S	8.5	9.4	8.9	41H22	115.0	81H22	231.0
H300L44	3.6	4.0	3.8	22L22	54.0	BS05L4S	8.5	9.4	8.9	41M44	99.0	81M44	198.0
				22L44	46.0	DS05L4S	8.5	9.4	8.9	44L44	74.0		
						OS10L4S	16.0	17.7	16.9				
						DS10L4S	16.0	17.7	16.9				
						OS15L4S	16.0	17.7	16.9				
						DS12L4S	16.0	17.7	16.9				
						BS12L4S	16.0	17.7	16.9				
						DS15L4S	16.0	17.7	16.9				
						BS15L4S	16.0	17.7	16.9				
						DS22L4S	26.3	29.0	27.7				
						BS22L4S	26.3	29.0	27.7				

**RECOMMENDED INITIAL
LOW PRESSURE CONTROL SETTING - PSIG**

Table 7

Minimum System* Temp. °F	R404A		R407A**		R448/449A**	
	Max Cut In	Cut Out	Max Cut In	Cut Out	Max Cut In	Cut Out
50	85	35	65	22	67	23
40	70	35	50	22	52	23
30	55	35	38	22	40	23
20	50	30	34	18	35	20
10	45	25	30	14	31	15
0	25	5	16	3" VAC	15	1
-10	20	1	10	4" VAC	11	4" VAC
-20	12	1	3	4" VAC	5	4" VAC
-30	8	0	1	4" VAC	2	4" VAC

* Minimum System Temperature is the coldest point in the system, whether it is the outdoor ambient or the refrigerated room temperature. the Minimum System Temperature dictates the low pressure control setting. When possible, keep the low pressure cut out at positive pressure. Low pressure controls are factory set at 15 PSI cut in and 3 PSI cut out.

** R407A, R448A and R449A settings reference dew pt.

**RECOMMENDED INITIAL
HIGH PRESSURE CONTROL SETTING - PSIG**

Table 8

R404A, R407A, R448/449A	
CUT IN	CUT OUT
315 - 320	390 - 400

**RECOMMENDED MINIMUM
MACHINE ROOM VENTILATION**

Table 9

SATURATED SUCTION °F	CFM PER HORSEPOWER
High Temp. +28 to +45	2,000
Med. Temp. +1 to +27	1,500
Low temp. -1 to -30	1,000

These estimates are based on limiting the equipment room ventilation air temperature rise to 10°F above the make up air. The total fresh air CFM must be available to the condenser coil inlets at design ambient. The temperature rise may be reduced by increasing the ventilation CFM.

High temperature CFM required = HT HP x 2000 = _____

Med. temperature CFM required = MT HP x 2000 = _____

Low temperature CFM required = LT HP x 1000 = _____

TOTAL estimated CFM required = (add above) _____

DEFROST

AIR DEFROST - An air defrost system, sometimes called off-cycle, is wired so that the evaporator fans run continuously, unless manually de-energized. Whenever the compressor stops, the room air (minimum = 34°F) warms the coils to room temperature melting the frost. It is essential that the frost completely melts and drains each time the compressor cycles off. If it does not, a partial defrost results, and the residual water and slush will re-freeze into ice during the next run cycle. Ice removal will require a manual defrost.

Adequate of cycle time is a function of system capacity. If the system is too small for the room, ice build-up will usually result. Use of an air defrost timer is sometimes successful on undersized systems to avoid coil icing. A temporary rise in room temperature will occur during the defrost cycle.

Optional defrost timers are suitable for Time Initiated, and either Time or Temperature terminated air defrost. Time termination is done by setting the fail-safe dial of the timer to the desired defrost duration. This keeps the compressor off during that duration. Temperature termination requires the mounting of a close-on-rise termination thermostat whose remote sensing bulb can be affixed to the coil at the point of heaviest frosting. The best setting for the termination temperature is usually the design room temperature.

ELECTRIC DEFROST - The recommended electric defrost circuitry is typical wiring designed for the Paragon 8145-20 and Grasslin DTSX defrost timers, with the addition of Lock-out Relay R1. This relay prevents the simultaneous operation of the compressor and the defrost heaters, and thus avoids the need for oversized wiring and service.

Relay R1 contact (4-5) is normally closed (relay de-energized), and is wired in series with the defrost heaters and terminal 3 (heater power) in the timer. Whenever R1 is energized, the relay contact opens, breaking the heater power circuit. R1 holding coil is in parallel with the compressor motor on single phase, or the compressor contactor holding coil (M1) on three phase, and is therefore energized any time the compressor starts. When the timer switches the system into defrost, the heaters will not energize until the compressor completes pumpdown and stops, even through the timer has applied power to terminal 3. If the compressor starts up for additional pumpdown during defrost, R1 energizes, breaking power to the heaters until the compressor stops again.

TIMER SETTING - Timers should be set to the correct time. Determine the number of defrost per day and the best time of day to occur. Insert defrost pins accordingly. Set the fail-safe time to terminate the defrost a few minutes beyond the estimated temperature termination time. Air defrost fail-safe (termination time) is usually 30 to 50 minutes. The colder the room, the longer the fail-safe time required. Electric defrost systems normally have a 25 to 35 minute fail-safe time. Hot gas defrost systems usually have a 15 minute fail-safe.

SUCCESSFUL DEFROSTING - Numerous factors should be considered when selecting and starting up low temperature refrigeration systems. For storage freezers holding packaged product, two defrost per day is normal. If the freezer has heavy usage with lots of door openings then three or four defrost per day may be required. For blast chilling and freezing or freezing of products with high moisture content, six or more defrost per day may be necessary. Do not have more defrosts than are necessary. Unnecessary extra defrosts add heat to the refrigerated space that must be removed. Excessive defrost periods may also cause steaming and lead to undesirable ice formation on the unit cooler, ceiling, and product.

Another factor to consider when determining the frequency of defrost is oil return. Oil will tend to settle out in the evaporator or suction line on low temperature systems. This oil should return to the compressor shortly after a defrost. Watch the compressor oil level. If it becomes low, a defrost may be needed for oil return. In critical situations an oil separator may be required. Two to four defrost per day are usually sufficient to maintain proper oil level in the compressor. Synthetic (POE) lubricants are considered more miscible with refrigerants than mineral oil and do not separate out as rapidly. Some installations may require only one defrost per day.

Evaporators with a medium frost load will defrost best. If the frost load is very light, the moisture cannot form water drops and run off the fins. Instead, it will vaporize off as steam and can create ice on colder surfaces like the ceiling, fan blades, fan guards, and evaporator housing. With medium frost loads, the frost will melt off as water and drain away. Too heavy a frost load will restrict air flow and cause uneven temperature in the freezer. Defrost with a medium frost load to maintain stable room temperature, optimum evaporator performance, and have a complete clearing of all frost.

Once ice forms in an evaporator coil it keeps building more ice and eventually will lead to equipment failure if not manually defrosted. Some symptoms of ice forming in the coil are: (1) Loss of air circulation and air throw, (2) Loss of room temperature, (3) No off-cycle time, (4) Floodback, and (5) Water spitting out of the fans or coil on air defrost systems. Long term ice formation will crush the refrigerant tubes in the coil causing leaks and major equipment problems. If ice formation is suspected, carefully check the interior rows of the coil with a good light. Ice formation usually starts at the bottom of the coil in the middle rows and can be difficult to detect. Any ice formation, however small, requires a manually assisted defrost. Clear 100% of the ice before placing a unit back into operation.

PRODUCT LOADING and AIR CIRCULATION

Always allow space for good air throw, air circulation, air return, cleaning and servicing of the evaporator unit. Always leave air circulation space between the products and walls of the cooler. Leave space between the boxes or cartons of product for the fastest temperature reduction or freezing. The larger the mass of product, the longer it takes to remove heat from the center of that mass. Divide the mass with air circulation space so the circulating cold air can carry the heat away from the product faster. Baffles may be required to direct air to specific areas of a room. How the product is stacked will influence pulldown time and stable product temperature. Direct the air to flow over and through the product. Refer to the evaporator location recommendations on page 4 to 5. It is a good practice to avoid stacking product closer than 12 inches to the evaporator drain pan. The room size, layout, aisle ways, height, door location, product stacking, and other factors influence the location of the evaporator. Locate evaporators so that the air pattern covers the entire room. Avoid placing evaporators above or close to doors. Direct the air stream

toward the door or down an aisle when possible. Use strip curtains on doors if they are open frequently or for extended periods. Minimize the entry of warm, humid, air into the room.

There are always exceptions to the guidelines for general use storage cooler or freezers. Special exceptions could be the product, air velocity, temperature, humidity, process, people, or machinery involved. Tomatoes, bananas, flowers, meat cutting and processing, and many other products have special requirements. Work or process rooms with people involved also have specifications requiring special attention. Facilities with USDA or other inspections can have special regulations and we suggest contacting the local inspector when selecting and locating equipment. Blast chill or blast freeze rooms may require special equipment or parts. We have years of experience and are always ready to assist you with special applications or projects.

Drawing 9

TYPICAL EVAPORATOR LOCATION IN A FREEZER

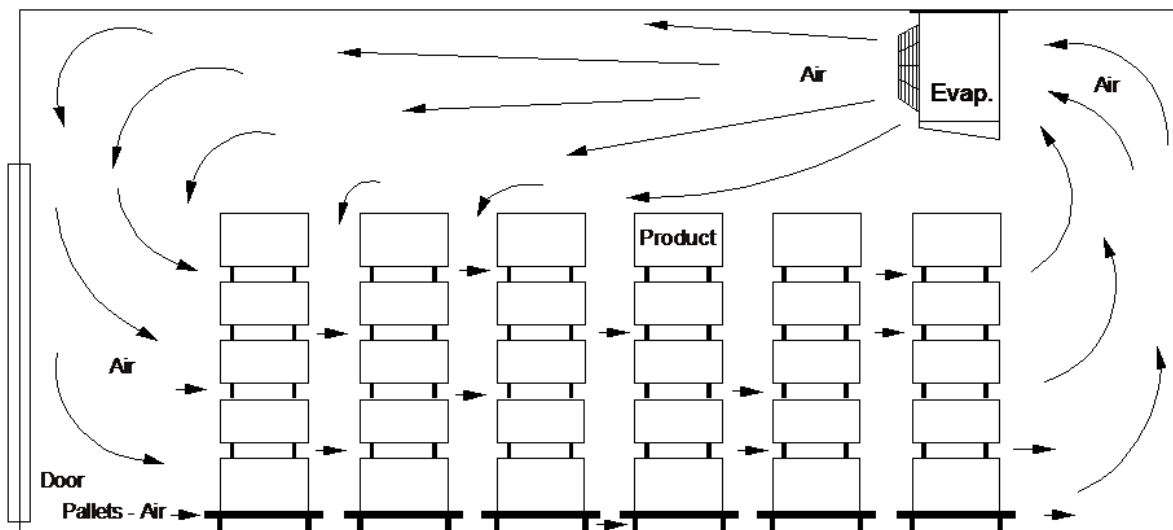

EVAPORATOR SUPERHEAT

Normally 6° to 12° is acceptable on most refrigeration systems. Preferably 6° to 8° on low temperature systems and 8° to 10° on medium temperature systems. Obtain evaporator superheat by measuring the suction line temperature at the expansion valve bulb. Obtain pressure at a Schrader fitting in the evaporator suction connection area, near the expansion valve bulb, and convert to dew point temperature with a

pressure-temperature chart. Subtract the converted temperature from the measured temperature and the difference is superheat at the evaporator. Obtain the desired superheat by adjusting the expansion valve. Evaporator superheat greater than 14°F can substantially reduce the evaporator and system capacity, while superheat less than 4°F has the potential for floodback.

COMPRESSOR SUPERHEAT

To improve compressor life expectancy 25° to 40° of compressor superheat is preferred. Copeland recommends a MINIMUM of 20°F superheat at the compressor. Compressor superheat is sometimes called suction superheat. Obtain compressor super-heat by measuring the suction line temperature about 6 to 12 inches from the compressor service valve. Obtain pressure at the suction service valve and convert to temperature with a pressure-temperature chart. Subtract the converted temperature from the measured temperature and the difference is superheat at the compressor. Compressor superheat is a critical value and should override evaporator superheat. Too low a compressor superheat can permit liquid return to the compressor causing damage or failure. Too high a compressor superheat can cause high discharge temperature, resulting in lubricant breakdown, compressor overheating and

can lead to compressor damage or failure. System capacity decreases as compressor superheat increases so superheat should be as low as practical, but with 20°F MINIMUM at all times. Compressor superheat can be changed by adjusting the expansion valve, adding a suction-liquid line heat exchanger, or by insulating just the suction line. Remember that increasing the superheat at the evaporator will decrease the evaporator capacity. For that reason, suction-liquid line heat exchanger are often used on systems with short line runs. Each system must be thoughtfully planned and adjusted to obtain optimum performance.

Maximum superheats must be observed with extended range models.

RETURN GAS TEMPERATURE

Although compressors may be capacity rated with 65°F return gas, most low temperature systems should not be operated at that condition. A 65°F return gas is usually acceptable on medium temperature systems. We recommend a 20°F to 40°F maximum return gas temperature on low temperature systems. Higher return gas temperatures on low temperature systems may cause compressor overheating and shorten

compressor life. Always maintain a minimum 20°F superheat at the compressor.

If necessary, insulate the suction line on low temperature systems to improve the return gas temperature and superheat at the compressor. Always observe maximum return gas temperatures noted in the product literature.

DISCHARGE LINE TEMPERATURE

The discharge line temperature should be measured about 6 inches down line from the compressor discharge service valve. Discharge line temperature has a direct relationship to internal temperatures in the compressor. A discharge line temperature of 220°F or lower is desirable and will improve compressor life expectancy. Maintaining a discharge line temperature below 220°F prevent oil breakdown, prevents excess wear on internal parts, and is assurance that the compressor is not overheating. Copeland recommends a MAXIMUM discharge line temperature of 225°F. “Lower is better”.

There is a relationship between discharge line temperature and return gas temperature. Lowering the return gas temperature by insulating the suction line will usually lower the discharge line temperature about the same degree.

Make sure low temperature compressor have a direct air blast over the compressor body. This air blast is essential to maintain proper cooling of low temperature compressors. Check head cooling fans for operation.

An operational check and adjustment is recommended after the room has pulled down to operating temperature and the outdoor ambient is above 70°F. To simulate design conditions, the condenser face can be partially blocked (Do not block condenser air blast cooling compressor body) to raise the head pressure. Carefully adjust each system for optimum performance and trouble free long life.

SCROLL COMPRESSOR OPERATION

LIQUID INJECTION

The low temperature scroll compressor is provided with an injection port suitable for connection to a source of liquid refrigerant. Internally, this port is connected to an inner pocket

of the scroll mechanism. Since this pocket is separated from the suction inlet, no loss of capacity or mass flow results from injecting at this point.

DISCHARGE TEMPERATURE CONTROL VALVE

The purpose of the DTC valve is to eliminate the need for a capillary tube on the 2 through 9 horsepower "ZF" scroll model family. The DTC valve is approved for all refrigerants in this

product range. A DTC valve must be used for ZF**K4E applications with R-407C, R-407A, R-448A and R-449A.

IPR VALVE

Refrigeration scroll compressors (up to 9 HP size) have internal pressure relief valves which open at a discharge to suction

differential pressure of 375 to 450 psi. This action will trip the motor protector and remove the motor from the line.

STARTING CHARACTERISTICS

Single phase scrolls are designed with PSC type motors and therefore will start without the need of start assist devices in most applications. However, if low voltage conditions exist at

start-up, protector trips can result. Therefore start assist devices (start capacitors & relays) are available to maximize starting characteristics under abnormal conditions.

BRIEF POWER INTERRUPTIONS

Brief power interruptions (less than 1/2 second) may result in powered reverse rotation of single phase Copeland Scroll compressors. High pressure discharge gas expands backwards through the scrolls at power interruption, causing the scroll to orbit in the reverse direction. If power is re-applied while this

reversal is occurring, the compressor may continue to run noisily in the reverse direction for several minutes until the compressor's internal protector trips. This has no negative impact on durability. When the protector resets the compressor will start and run normally.

THREE PHASE SCROLL COMPRESSORS – DIRECTIONAL DEPENDENCE

Scroll compressors are directional dependent; i.e. they will compress in one rotational direction only. Three phase scrolls will rotate in either direction depending on power phasing. Since there is a 50/50 chance of connected power being "backwards", contractors should be warned of this. Appropriate instructions or notices should be provided by the

OEM. Verification of proper rotation can be made by observing that the suction pressure drops and the discharge pressure rises when the compressor is energized. No time delay is required on three phase models to prevent reverse rotation due to brief power interruptions.

TROUBLE-SHOOTING REFRIGERATION SYSTEMS

PROBLEM	POSSIBLE CAUSES	POSSIBLE CORRECTIVE ACTION
<p style="text-align: center;">COMPRESSOR WILL NOT RUN</p>	<ol style="list-style-type: none"> 1. Fused disconnect switch or circuit breaker open. 2. Blown fuse or tripped breaker. 3. Low line voltage. 4. Compressor motor protector open. 5. Defective compressor contactor. 6. Open room thermostat . 7. Open low pressure control. 8. Open defrost timer. 9. Open oil failure switch. 10. Liquid line solenoid will not open. 11. Compressor motor defective. 12. Loose wiring. 	<ol style="list-style-type: none"> 1. Close switch and / or breaker. 2. Check for reason and repair. Replace fuse after correcting problem. 3. Check line voltage; if more than 10% from compressor marking, correcting is necessary. 4. Motor protector automatically resets. Allow time for compressor to cool down so protector will reset. Restart and check for reason overheat occurred. 5. Replace contactor. 6. Check room temperature. If temperature is proper, wait for thermostat to close. 7. Check low pressure control settings. See page 20 for initial settings and adjust as required. 8. Check defrost timer for proper operation. Replace if defective. 9. Check for causes of low pressure and reset switch. 10. Check holding coil; replace if defective. 11. Check motor for open circuit, short-circuit, grounded windings or burn-out. 12. Check all wire terminals and tighten as necessary.
<p style="text-align: center;">COMPRESSOR NOISY OR VIBRATING</p>	<ol style="list-style-type: none"> 1. Flooding of liquid refrigerant into crankcase 2. Compressor hold-down nuts too tight. 3. Scroll compressor rotation sensitive. 4. Worn or damaged compressor. 	<ol style="list-style-type: none"> 1. Check expansion valve superheat setting. 2. Loosen compressor hold-down nuts until compressor floats freely on mounting springs. 3. Rewire for reverse rotation. 4. Replace the compressor.
<p style="text-align: center;">HIGH HEAD PRESSURE</p>	<ol style="list-style-type: none"> 1. Too much refrigerant. 2. Non-condensibles in system. 3. Dirty condenser coil. 4. Condenser fan not running. 5. Discharge valve partially closed. 	<ol style="list-style-type: none"> 1. Remove excess refrigerant. 2. Remove non-condensibles from system. 3. Clean condenser coil. 4. Check electrical circuit and fuse. Check fan cycling controls. 5. Open valve.
<p style="text-align: center;">HIGH SUCTION PRESSURE</p>	<ol style="list-style-type: none"> 1. Improper suction pressure regulator setting. 2. Thermostatic expansion valve pressure limit feature incorrect or inoperative. Overfeeding. 3. Damaged valves in compressor. 4. Worn piston rings and/or cylinder. 5. Room load too large. 	<ol style="list-style-type: none"> 1. Check electrical circuit and fuse. Check fan cycling 2. Check bulb location and clamping. Adjust superheat. Replace expansion valve power head 3. Replace valve plate or compressor. 4. Replace compressor. 5. Reduce the load or add more equipment.

TROUBLE-SHOOTING REFRIGERATION SYSTEMS

PROBLEM	POSSIBLE CAUSES	POSSIBLE CORRECTIVE ACTION
LOW HEAD PRESSURE	<ol style="list-style-type: none"> 1. Insufficient refrigerant. 2. Faulty condenser temperature controls. 3. Damaged valves in compressor. 4. Worn piston rings and/or cylinder. 	<ol style="list-style-type: none"> 1. Check system for leaks. Repair leaks and add refrigerant. 2. Check condenser controls and reset to obtain desired condensing temperature. 3. Replace valve plate or compressor. 4. Replace compressor.
LOW SUCTION PRESSURE	<ol style="list-style-type: none"> 1. Insufficient refrigerant 2. Unit cooler iced up or air flow restricted. 3. Plugged liquid line filter-drier. 4. Plugged suction filter. 5. Improper suction pressure regulator setting. 6. Expansion valve superheat too high or valve too small. 	<ol style="list-style-type: none"> 1. Check system for leaks. Repair leaks and add refrigerant. 2. Check defrost system. Clean the coil. check fan operation. Check air flow. 3. Replace filter-drier or cartridges. 4. Replace the suction filter. 5. Check setting and correct as required. 6. Adjust valve for proper superheat or replace the expansion valve if too small.
LOSS OF OIL OR LOW OIL PRESSURE	<ol style="list-style-type: none"> 1. Insufficient oil in system. 2. Compressor short cycling. 3. Defective oil pressure control. 4. Loose fittings on pump housing, compressor or oil lines. 5. Too much liquid refrigerant in the crankcase. 6. Plugged suction oil strainer. 7. Worn oil pump. 8. Worn compressor bearings. 	<ol style="list-style-type: none"> 1. Thoroughly defrost evaporator. After defrost, observe level, add oil. Check for leaks. Check lines for proper slope and traps. 2. Check low pressure control settings. 3. Replace oil pressure control. 4. Check and tighten system. Check bottom plate on compressor. 5. Adjust expansion valve for higher superheat. Check crankcase heater. 6. Clean oil strainer. 7. Replace the oil pump. 8. Replace the compressor.
ICE BUILD UP ON CEILING, EVAPORATOR GUARDS OR FAN BLADES	<ol style="list-style-type: none"> 1. Defrost time is too long. 2. Too many defrost. 3. Defective fan delay, defrost termination, or timer. 4. Voltage too high. 5. Ambient air leaks into room. 	<ol style="list-style-type: none"> 1. Adjust defrost termination thermostat. 2. Reduce number of defrost. 3. Replace the defective component. 4. Reduce voltage to defrost heaters. 5. Seal all air leaks.
COIL NOT CLEARING DURING DEFROST	<ol style="list-style-type: none"> 1. Coil temperature not getting high enough during defrost, or defrost cycle too short. 2. Not enough defrost per day. 3. Defective defrost controls or timer. 4. Voltage too low. 	<ol style="list-style-type: none"> 1. Check heater operation. Check termination temperature. Adjust defrost thermostat for longer defrost. 2. Set timer for more defrost. 3. Replace defective component. 4. Increase voltage to defrost heaters.

WATER COOLED CONDENSER MAINTENANCE

SHELL & TUBE CONDENSER

General : The unit should be level with no horizontal pitch. Connect water lines according to the local plumbing codes.

Fittings : Fittings should be in line so that they are not under tension or forced in anyway. Vibration isolation should be used. If the fittings are out of line or under strain, threads on the fittings may be damaged. Brazed connections must also be carefully aligned before brazing.

Testing : Test for water circuit leaks. Water flow rates below eight feet per second are recommended. Higher velocity through the tubes results in greater risk of impingement corrosion and tube failure.

WATER CONNECTIONS FOR CITY

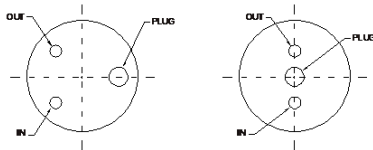

WATER CONNECTIONS FOR TOWER

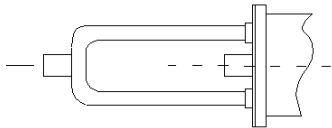

Draining : Theoretically it is easy to drain a condenser; in practice it is complex. As much as 20% of the water in the condenser can be retained if the service technician simply opens the vent and drain fittings on the condenser. To fully drain all water from the condenser tubes, it is necessary to take off the back plate and tilt the condenser a minimum of 5 degrees.

Chemical Cleaning : Use only preparations from an established, reliable source. Follow directions exactly, particularly regarding amounts to use and flushing or neutralizing procedure after cleaning.

Mechanical Cleaning : Drain water from condenser. Remove the nuts, water plates and gaskets from both ends of the condenser. If space is limited, the tubes can be cleaned with only one open end, however it is difficult to flush out closed ended passages.

Cleaning Procedure : Gaskets need only to be rinsed in running water. A rag or soft brush is all that is needed to remove rust any foreign matter. Clear water or a soft brush such as a paint brush should be used to clean the inside of the water end plates.

DO NOT SCRATCH OR DAMAGE THE EPOXY COATING ON THE INSIDE SURFACE OF THE END PLATES. NEVER USE A WIRE BRUSH OR STRONG CAUSTICS ON THESE SURFACES.

Condenser tubes should be flushed clear with air or water. If a rough coating remains inside the tubes, further cleaning is desirable. Nylon, brass or Copper brushes are recommended. Never use any tool which will scratch or otherwise damage the tube surface. Stop when a few places begin to show a Copper color.

After cleaning, wipe all foreign matter from the tube sheets and stubs. To reassemble, replace clean gaskets, water end plates and nuts. Test for leaks. If no leaks are found, the condenser should be isolated from the remaining system and evacuated. After assuring that there are no refrigerant circuit leaks the condenser can be replaced into the system.

SYSTEM START -UP CHECK LIST

Customer _____ Job Name _____
 City / State _____ System No. _____ Date _____
 Condensing Unit Model No. _____ Serial No. _____
 Evaporator Model No. _____ Qty. _____ Serial No. _____
 Room No. or Name _____ Design Temp. _____ °F Size(Ft.) _____ L x _____ W x _____ H
 Suction Line _____ OD Liquid Line _____ OD Equivalent Length _____ Ft. Liquid Lift _____ Ft.
 Leak Test at _____ PSIG, For _____ Hours System is Leak Free _____
 Evacuated _____ Times to _____ Microns + Final Vacuum to _____ Microns, for _____ Hours Total Hrs _____
 Sight Glass Dry _____ Pressure Controls Set _____ Thermostat Set _____ Outdoor Ambient _____ °F
 Design Voltage _____ Test Volts _____ Control Circuit Volts _____
 Disconnect Fuse Size _____ Amps Control Circuit Fuse _____ Amps Estimated Refrigerant Charge _____ Lbs.
 Refrigerant R- _____ Charge _____ + _____ + _____ = _____ Total Lbs. Sight Glass Clear _____
 Compressor Oil Level _____ Glass Evap. Fans Running _____ Room Temp at Start-up _____ °F
 Room Temp. at 1 Hr. _____ °F Compressor Oil Level _____ Glass Defrost Timer Set _____
 Room Temp. at 2 Hr. _____ °F Compressor Oil Level _____ Glass Sight Glass Clear _____
 Room Temp. at 4 Hr. _____ °F Compressor Oil Level _____ Glass Outdoor Ambient _____

Electrical Component	Specplate Amps	Test Amps		
		L1	L2	L3
Compressor	_____	_____	_____	_____
Condenser	_____	_____	_____	_____
Evaporator	_____	_____	_____	_____
Defrost Heaters	_____	_____	_____	_____

Evaporator Suction Temp _____ °F Evaporator Suction Pressure _____ PSIG
 Convert PSIG to _____ °F Evaporator Superheat _____ °F
 Compressor Suction Temp _____ °F Compressor Suction Pressure _____ PSIG
 Convert PSIG to _____ °F Compressor Superheat _____ °F Sight Glass Clear _____
 Compressor Discharge Pressure _____ PSIG Compressor Discharge Line Temp _____ °F
 Liquid Temp. Leaving Condensing Unit _____ °F Liquid Temp. Entering Expansion Valve _____ °F

Evaporator Drain Line Trapped _____, Heated _____, Sloped _____, Will not freeze up _____
 Type of Defrost: _____ Air _____ Electric _____ Hot Gas Defrost Time _____ Min. Is Coil Clean? _____
 Temperature Termination _____ Fan Delay _____ Is Defrost Satisfactory? _____
 Compressor Oil Level _____ Glass Timer Set _____ Defrost per Day with _____ Minute Fail Safe

**FINAL
CONDITION**

Room Thermostat Set at _____ °F Room Temp. Holding at _____ °F
 Evaporator Superheat _____ °F Sight Glass Clear _____ Pumpdown OK _____
 Compressor Superheat _____ °F Compressor Oil Level _____ Glass
 Discharge Line Temperature _____ °F Suction Pressure _____ PSIG

Start-Up By: _____ Company: _____ Phone: _____

REFRIGERATION SYSTEM SERVICE RECORD

Customer _____ Job Name _____

City / State _____ System No. _____ Date _____

Condensing Unit Model No. _____ Serial No. _____

Evaporator Model No. _____ Qty. _____ Serial No. _____

Room No. or Name _____ Design Temp. _____ °F Actual Room Temp. _____ °F

Date System was Installed _____ Product Stored _____ Total Pounds _____

Routine / Scheduled Preventive Maintenance Service Call Outdoor Ambient _____ °F

Service Requested _____

Service Performed _____

Design Voltage _____ Actual Voltage _____ Refrigerant R- _____

Electrical	Specplate	Test Amps		
Component	Amps	L1	L2	L3
Compressor	_____	_____	_____	_____
Condenser	_____	_____	_____	_____
Evaporator	_____	_____	_____	_____
Defrost Heaters	_____	_____	_____	_____

Evaporator Suction Temp _____ °F Evaporator Suction Pressure _____ PSIG

Convert PSIG to _____ °F Evaporator Superheat _____ °F

Compressor Suction Temp _____ °F Compressor Suction Pressure _____ PSIG

Convert PSIG to _____ °F Compressor Superheat _____ °F Sight Glass Clear _____

Compressor Discharge Pressure _____ PSIG Compressor Discharge Line Temp _____ °F

Compressor Oil Level _____ Glass Sight Glass Clear _____ Sight Glass Dry _____

Cond. Coil Clean _____ All Cond. Fans Operate _____ Liquid Temp. Leaving Cond. Unit _____ °F

Room Thermostat Set at _____ °F Room Temperature Holding at _____ °F

Evaporator Coil Clean _____ Drain Pan Clean _____ Fan Blades / Guards Clean _____

All Evap. Fans Operate _____ Room Air Circulation OK _____ Defrosting OK _____

System Pumpdown OK _____ Cooler and Equipment in Safe Condition _____

System Notes: _____

Serviced by _____

SYSTEM MAINTENANCE

Remove all leaves, grass, paper, lint, fluff, soil, feathers, cottonwood hair, or other materials from the condenser coil with a brush, blower, or vacuum. Grease and dirt removal may require washing with a coil cleaning detergent. **Always rinse thoroughly with clean water after using a chemical cleaner. Do not use cleaners containing ammonia.** The coil must be kept clean at all times. Be sure the condenser fans are operating and the air flow is not restricted. Keep the condensing unit area clean.

There is additional oil installed in the compressor to allow for a limited amount to circulate throughout the system with the refrigerant. The oil is clear and can be difficult to see if above the oil level glass. The longer the compressor runs the lower the oil level may go. The oil level may approach the bottom of the glass before the system cycles off or a defrost occurs. After an off cycle or defrost period, the oil normally returns to the compressor. Once the room is down to design temperature the oil level range should be about 1/8 to 5/8 glass.

Excess oil dangerous to the compressor. Do not add oil just because the oil safety trips out. Thoroughly check out the loss oil or oil pressure on trouble-shooting, page 24, before adding oil. Correct any condition that prevents oil return to the compressor. Visually check the oil pump, oil lines, and compressor bottom plate area for oil leaks.

Add only lubricant approved by the compressor manufacturer. Polyol ester, "POE", synthetic lubricant must be used with R404A, R407A, R407C, R448A/R449A and R507 systems. Take caution not to fill above 1/2 glass. POE lubricants quickly absorb moisture from the atmosphere. The system must be kept sealed as much as possible to prevent moisture contamination.

Check the system pressures and temperatures on a regular basis to be sure they are within the guidelines recommended on page 21. Refer to trouble-shooting on page 23 and 24 for suggestions.

Evaporators should be checked frequently and cleaned of dirt and grease accumulation. Disconnect electrical power to the evaporator when inspecting or cleaning. The fan blades, fan guards and coil may require frequent cleaning. Do not use ammonia or other cleaning chemicals that are corrosive to Copper or Aluminum. The drain pan should be lowered for inspection and thoroughly cleaned to prevent buildup of foreign materials. Make sure the drain connection area is clean and clear.

Make sure all motors and fans are in good operating condition. If uneven frosting of the coil is observed, look for air leaking into the room. Eliminate all air leaks for optimum evaporator performance and energy savings. Do not leave the access panels off after adjustment or service. The access panels should always be in place when the evaporator is operating. Keep cold room doors closed when possible.

TO INQUIRE OR ORDER REPLACEMENT PARTS

Email: parts@htpgusa.com Telephone (800) 288-3488 or (256) 259-7400 Fax (256) 259-7478

1. Provide the complete Model Number and Serial Number of the unit.
2. Provide a detailed description of the part with any model, diameter, HP, or other markings.
3. State the quantity you are ordering.
4. Advise special shipping methods, routes, procedures, or instructions with ship to address.
5. Provide complete and accurate data to insure prompt and accurate delivery.
6. Compressors and compressor parts must be obtained from your local wholesaler.