



HOT WATER ON DEMAND

Enjoy fast hot water delivery to faucets and showers, saving time and reducing hot water waste

- **INSTANT HOT WATER** – Get hot water where you want it and when you need it
- **ACTIVATION FLEXIBILITY** – Choose the best activation method that meets your needs
- **WATER CONSERVATION** – Reduce water waste by not waiting for hot water, saving up to 12,000 gallons of water per year*

Plus, on-demand recirculation pumps can be used with any Ruud Tankless or Ruud Tank-Type water heater

DEMAND PUMP KIT – STANDARD

The standard on-demand recirculation pump is an easy install solution and perfect for new construction, meeting on demand activation regulations for new homes.

APPLICATIONS – New construction

INSTALL LOCATION – Next to the water heater

ACTIVATION – Wired push button (included), motion sensor or remote transmitter

PLUMBING REQUIREMENTS – Requires a dedicated return line

COMPATIBILITY – Tank-type and tankless water heaters

DEMAND PUMP KIT – UNDER SINK

This under the sink option is a perfect solution for adding instant hot water to an existing water heater piping application.

APPLICATIONS – Retrofit and new construction

INSTALL LOCATION – Under sink cabinet of the fixture furthest from your water heater

ACTIVATION – Wired push button (included), motion sensor or remote transmitter

PLUMBING REQUIREMENTS – Uses existing cold water supply pipe as the return line – no dedicated return line required

COMPATIBILITY – Tank-type and tankless water heaters

KIT: AP18403



KIT CONTAINS

- 008-CT Taco Genie
- Wired push button
- Piping diagrams and instruction sheets for ease of installation

KIT: AP18537



KIT CONTAINS

- 008-CT Taco Genie
- Wired push button
- Piping diagrams and instruction sheets for ease of installation
- + 2 Tee fittings
- + 2 Corrugated flex tubes

MAX. PIPE LENGTHS

- 400 ft. total pipe length – 3/4" copper pipe
- 100 ft. total pipe length – 1/2" copper pipe

*Savings per News Bulletin released by the United States Department of Energy / Oak Ridge National Laboratory, November 2002 study on water and energy savings in residential homes using hot water recirculating system.





DEMAND PUMP KIT – STANDARD PIPING DIAGRAM

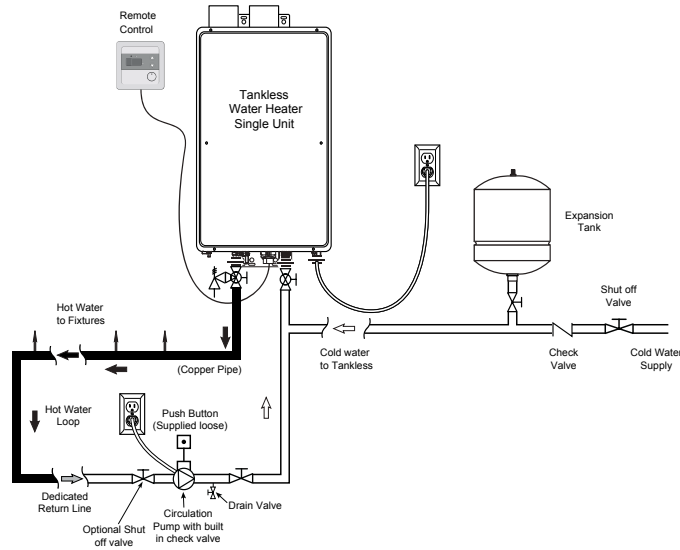

DEMAND PUMP KIT – UNDER SINK PIPING DIAGRAM

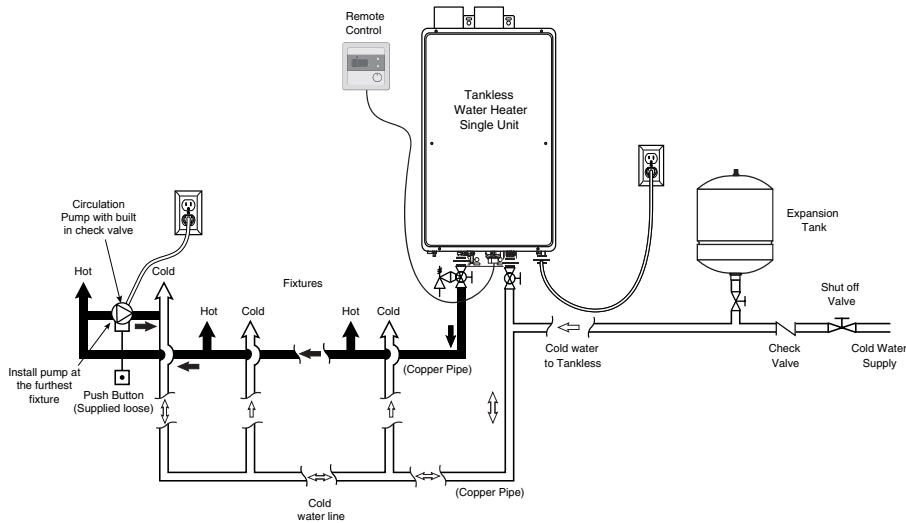

ACTIVATION ACCESSORIES



WIRED PUSH BUTTON – Install the wired push button at the point of use for easy and convenient system activation.

Part No: SP20863



MOTION SENSOR KIT – Install the motion sensor at the point of use so homeowners don't have to lift a finger to activate the system.

Part No: SP20862



REMOTE TRANSMITTER KIT – Utilize the remote transmitter kit to activate the system via a small remote button without being next to the point of use.

Part No: SP20861

Pump kits and activation accessories can be ordered through Ruud Parts. For more information call 800-621-5622.

In keeping with its policy of continuous progress and product improvement, Ruud reserves the right to make changes without notice.

Ruud Water Heating • 101 Bell Road
 Montgomery, Alabama 36117-4305 • 1.800.621.5622

PRINTED IN U.S.A. 02/17 WP FORM NO. TKR-508

