

INSTALLATION & OPERATING INSTRUCTIONS

Electric SPA-PAK Heater



Models
ELS 552-2 & ELS 1102-2



FOR YOUR SAFETY: Do not store or use gasoline or other flammable vapors and liquids or other combustible materials in the vicinity of this or any other appliance. To do so may result in an explosion or fire.

WATER CHEMISTRY

For your health and the protection of your pool equipment, it is essential that your water be chemically balanced. The following levels must be used as a guide for balanced water.

CAUTION: Corrosive water voids all warranties.

Occasional chemical shock dosing of the pool or spa should not damage the heater providing the water is balanced.

Automatic chemical dosing devices and salt chlorinators are usually more efficient in heater water, unless controlled, they can lead to excessive chlorine level which can damage your heater.

Further advice should be obtained from your pool or spa builder, accredited pool shop, or chemical supplier for the correct levels for your water.

Recommended Level(s)	Fiberglass Pools	Fiberglass Spas	Other Pool and Spa Types
Water Temperature	68-88°F (20-31°C)	89-104°F (31-40°C)	68-104°F (20-40°C)
pH	7.3-7.4	7.3-7.4	7.6-7.8
Total Alkalinity (ppm)	120-150	120-150	80-120
Calcium Hardness (ppm)	200-300	150-200	200-400
Salt (ppm)	6000 Maximum	6000 Maximum	6000 Maximum
Free Chlorine (ppm)*	2-3	2-3	2-3
Total Dissolved Solids (ppm)	3000 Maximum	3000 Maximum	3000 Maximum

*Free Chlorine **MUST NOT EXCEED 5 ppm!**

INTRODUCTION

The Spa-Pak spa Heaters have been designed to provide efficient, pollution-free, electric pool heating while requiring minimal installation. The Spa-Pak consists of a sheathed resistance element installed in a copper tank.

This tank has a 1-1/2" inlet and outlet on the side for plumbing connections. The heater voltage is 208/240V single-phase. The control circuit passes through a manual switch, the temperature control, and the magnetic contactor coil. All items are pre-wired and installed in a baked enamel steel case.

It is essential that the heater be installed in accordance with the instructions given herein. Failure to do so may cause damage to the heater and to the equipment to which it is connected, or may prevent the heater from operating in a correct manner. The heater is to be installed in accordance with article 680 of the National Electrical Code ANSI/NFPA No. 70. Consult State and local codes BEFORE installing this unit. Where such codes have requirements beyond the instructions given herein, the codes shall have precedence over these instructions.

Location

These heaters are listed by UL for either indoor or outdoor use. Unit must be mounted on a level base parallel to the ground. Allow 6" clearance at sides and 18" clearance at top and front for maintenance. Secure the unit with 5/16" mounting hardware using the holes provided. The heater must be located where leakage of heat exchanger or connections will not damage the area adjacent to the heater or structure.

Water Connections

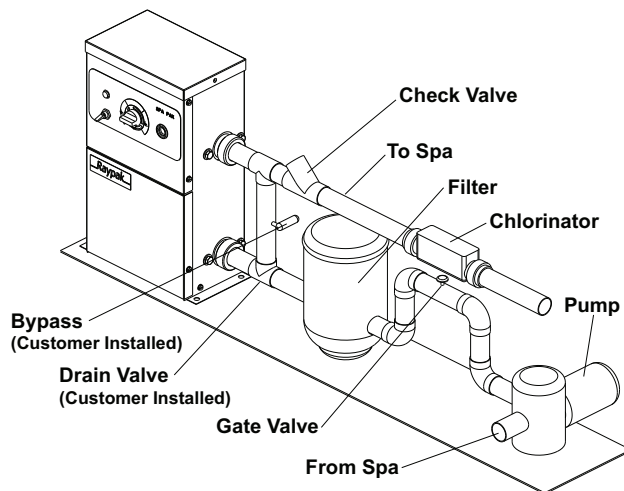

NOTE: PVC pipe may be used.

NOTE: When using two speed pumps, do not install gate valve on inlet.

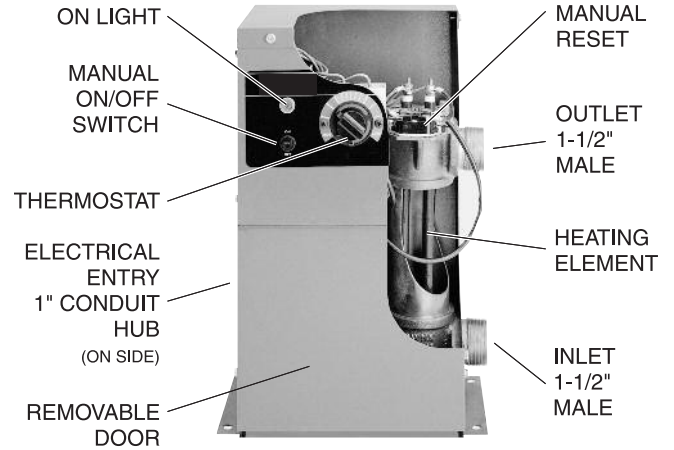

The Spa-Pak has 1-1/2" male NPT inlet and outlet connections at the right side of the heater. The inlet is at the base of the heater and must be piped directly to the filter discharge to ensure proper flow direction. Minimum flow rate through the heater is 15 gpm, maximum is 60 gpm. If this is exceeded, an external bypass must be added as shown. Unions should be used on piping connections. A shut-off valve should be included on the heater inlet to prevent draining the spa when performing maintenance.

CAUTION: No shut-off valves are to be installed in the piping between the heater outlet and the spa. Any chlorinators, valves, etc., that can cause return line blockage will void the warranty.

Automatic Chlorinators and Chemical Feeders

All chemicals must be introduced and completely diluted into the spa water before being circulated through the heater. Do not place chlorine tablets or bromine sticks in the skimmer. High chemical concentrations will result when the pump is not running (e.g. overnight).

Chlorinators must feed downstream of the heater and have an anti-siphoning device to prevent chemical backup into the heater when the pump is shut off.

CAUTION: High chemical concentrates from feeders and chlorinators that are out of adjustment will cause very rapid corrosion to the heater. Such damage is not covered under the warranty.

Thermostat

The heater thermostat located on the front of the unit, may be set for any desired spa temperature.

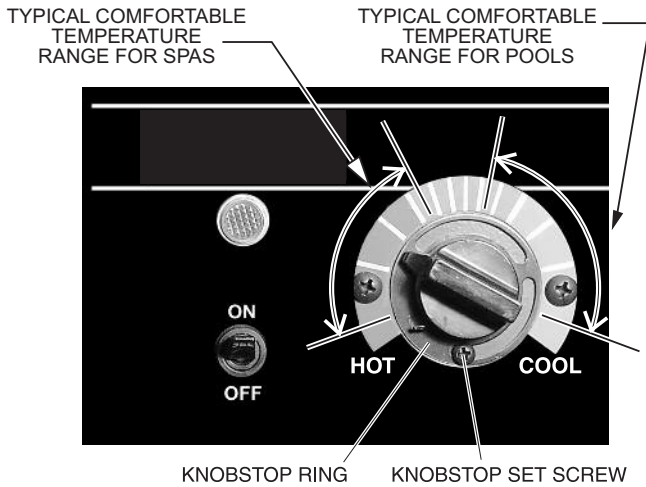

Maximum Temperature Setpoint (Knobstop Adjustment)

Adjustment to a different maximum setting is a simple task. Loosen the small set screw on the knobstop and rotate the knobstop ring until vertical "stop" tab is at the desired maximum setting. Retighten the set screw.

ELECTRICAL

WARNING: The power supply circuit to this heater shall be protected by a ground-fault circuit interrupter (GFCI), in accordance with Art. 680 of the latest edition of the National Electrical Code (NEC). Failure to do so could result in severe personal injury or death.

The GFCI devices shall be of the self-contained types, circuit breaker types or the receptacle types. Feeder ground-fault protection is not required where GFCI is already provided in the branch circuits or receptacles supplying power to the heater.

Electrical Disconnect

An electrical disconnect and over-current protection device must be provided in accordance with local

codes. Keep wire runs as short as possible to minimize voltage drop. Bring wires of size indicated from a fused disconnect switch (customer furnished) with an amp rating of at least 125% of the amp rating shown on the spa heater nameplate. A ground lug is provided for connection to the supply ground. A wiring diagram of the heater is shown at right. It is also affixed to the inside front cover of the units.

Field Wiring

Heater requires three-wire service. With 240 VAC there are two hot wires and a grounding conductor. Even when metallic conduit is used, the grounding conductor must be run to the supply ground.

Field wiring connections are made to the electrical entry at the left side of the unit. A hole in the jacket is provided for a 1" trade size conduit hub. The location of the field wiring box is shown below. Wire nuts are used to connect all leads except the grounding conductor, for which a pressure lug is provided.

NOTE: Heater grounding conductor shall be the same or larger than the live power supply conductor.

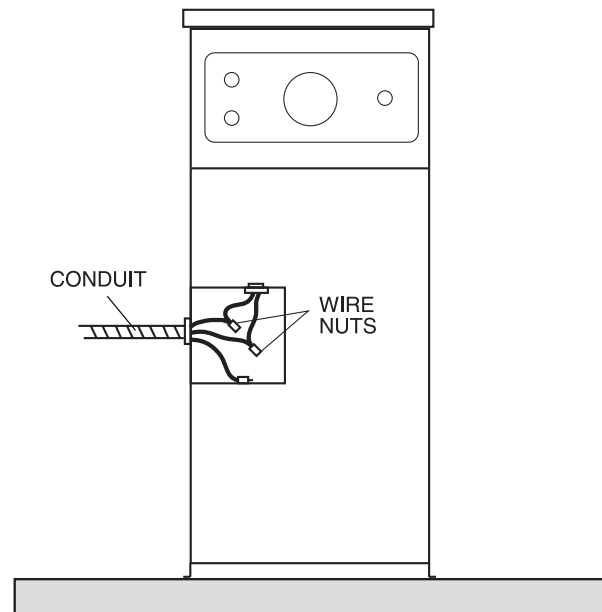

Recommended Wire Sizes for Field Connection

Use type THWN copper wire to the unit, with the AWG wire sizes (Internal wire sizes may differ) listed in Table A on the following page.

Model	Amp Draw	Conduit Size	Wire Size (including ground)	Size of Fused Disconnect (amps)
ELS 1102-2	46	1"	6	60
ELS 552-2	23	*1/2"	10	30

*Use a reducer bushing.

Table A: Wire Sizes for Field Connection

LADDER DIAGRAM

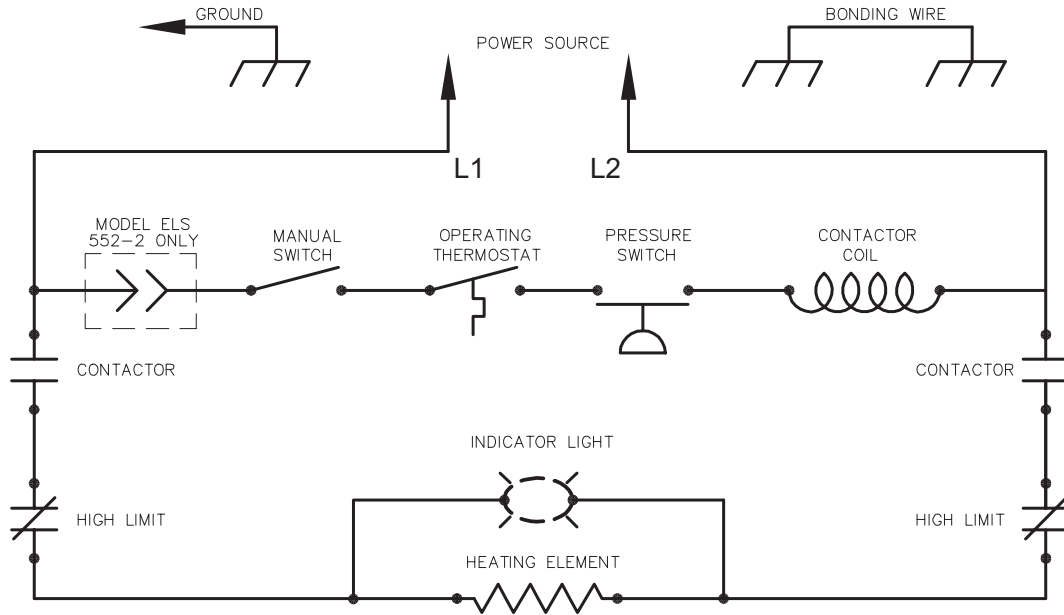

SCHEMATIC DIAGRAM

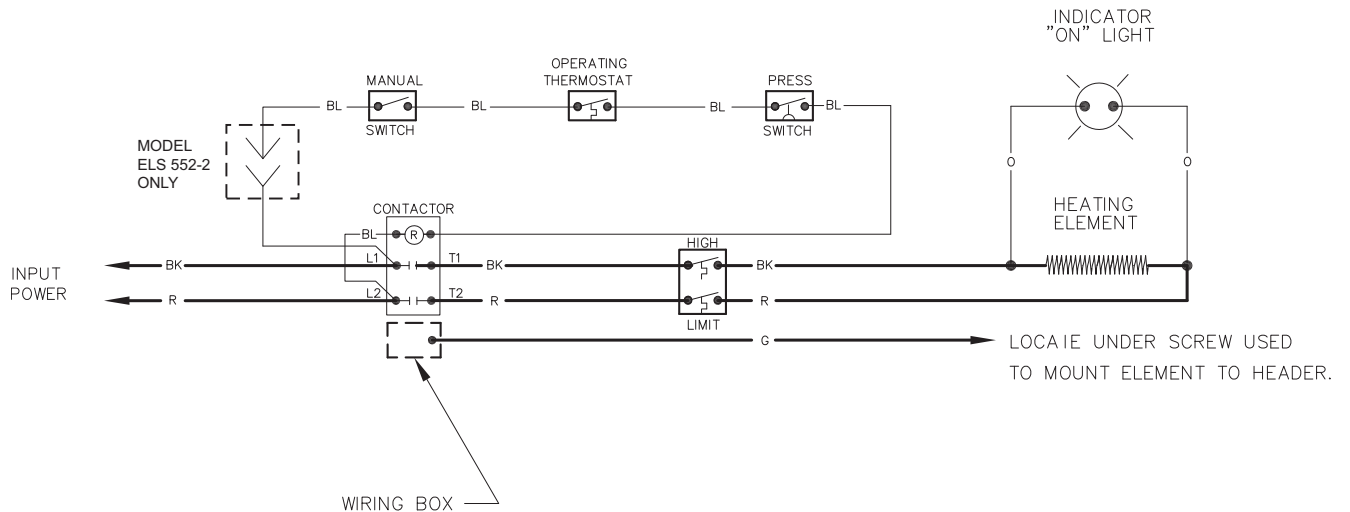

Controls

Spa-Pak spa heaters have integral thermostats and contactors. They are also equipped with a high temperature limit thermostat which will open the circuit cutting off power to the heating element in the event of excessive water temperature. This high limit thermostat is factory set at 140°F. A pressure switch is utilized to ensure water flow through the heater before the unit will function.

NOTE: The filter must be kept clean so the flow rate will be maintained above 15 gpm. Failure to do so will cause the pressure switch to drop out, and the heater will become inoperative.

OPERATION

Preliminary

MAKE SURE THAT POWER TO THE UNIT IS OFF.

Remove any tools or other foreign objects from the inside of the unit. Replace the removable lower panel. Place temperature control in the off position. Check tightness of electrical screw terminals.

Filling

Open all valves in the inlet piping and fill the system with water. Turn on the filter pump and purge all air from the system. On in-ground spa installations it may be necessary to prime the pump. Check the unit and all piping connections for leaks.

Start-up

FILTER PUMP MUST BE ON FOR THE HEATER TO OPERATE. Turn on the main power to the unit, then set the temperature control to the desired position and turn the switch to the "ON" position to place the heater in operation. Shut pump off and on to be certain that heater shuts off when pump is off.

A thermal cutout prevents the unit from overheating. Should overheating occur, the control circuit may be made operational by depressing the manual reset button through the grommet on the front panel. This will be possible only after the unit has cooled down for several minutes.

IMPORTANT SAFETY INSTRUCTIONS

CAUTION: Elevated water temperature can be hazardous.

The U.S. Consumer Product Safety Commission recommends the following guidelines. When using this electrical equipment, basic safety precautions should always be followed, including the following:

1. **READ AND FOLLOW ALL INSTRUCTIONS.**
2. To reduce the risk of injury:
 - a. The water in a pool or tub should never exceed 104°F (40°C). A water temperature in excess of 104°F is considered unsafe for all persons. Lower water temperatures are recommended for extended use (exceeding 10 – 15 minutes) and for young children.
 - b. Since excessive water temperatures have a high potential for causing fetal damage during the early months of pregnancy, pregnant or possibly pregnant women should limit pool or tub water temperatures to 100°F (38°C).
 - c. Before entering a pool or tub, the user should measure the water temperature at several occupant locations using an accurate thermometer since the tolerance of water temperature-regulating devices may vary as much as ±5°F (±3°C).
 - d. Alcohol, drugs, or medication should not be used before or during pool or tub use since their use may lead to unconsciousness with the possibility of drowning.
 - e. Persons suffering from obesity or with a medical history of heart disease, low or high blood pressure, circulatory system problems, or diabetes should consult a physician before using a pool or tub.
 - f. Persons using medication should consult a physician before using a pool or tub since some medication may induce drowsiness while other medication may affect heart rate, blood pressure, and circulation.

WARNING: The use of alcohol, drugs, or medication can greatly increase the risk of fatal hyperthermia in pools and tubs.

NOTE: Hyperthermia occurs when the internal temperature of the body reaches a level several degrees above the normal body temperature of 98.6°F (37°C). The symptoms of hyperthermia include dizziness, fainting, drowsiness, lethargy, and an increase in the internal temperature of the body. The effects of hyperthermia include (1) unawareness of impending hazard, (2) failure to perceive heat, (3) failure to recognize the need to exit pool or tub, (4) physical inability to exit pool or tub, (5) fetal damage in pregnant women, and (6) unconsciousness resulting in a danger of drowning.

3. A green terminal (or wire connector marked "G", "GR", "GROUND" or "GROUNDING") is provided within the control box. To reduce the risk of electric shock, connect this terminal or connector to the grounding terminal of the electric service or supply panel with a continuous copper wire in accordance with the Canadian Electrical Code, Part I.
4. This product shall be protected by a Class A ground fault circuit interrupter (GFCI).
5. **SAVE THESE INSTRUCTIONS.**

Pressure Switch Adjustment

Pressure switch is normally factory set for universal spa applications. Heater must not be installed more than five feet above water level or five feet below. If the heater is installed below the spa level or if a two speed filter pump is used it is necessary to reset the pressure switch as follows:

1. With pump and heater on, turn adjustment knob clockwise until a click is heard.
2. Turn adjustment knob counter clockwise 1/4 turn.
3. Turn pump off and on several times. Heater should shut off immediately. If it does not, repeat steps above until proper adjustment is made.

Shut Down

Turn off electrical power to heater at main disconnect when draining spa.

MAINTENANCE

WARNING: ONLY QUALIFIED PERSONNEL SHOULD ATTEMPT MAINTENANCE ON THIS EQUIPMENT (N.E.C. ARTICLE 100-1971) (MAINTENANCE MUST BE DONE WITH MAIN DISCONNECT OPEN).

Spa Water Chemistry

Chemical imbalance can cause severe damage to your heater and associated equipment. Maintain your water chemistry according to the chart on page 8. If the mineral content and dissolved solids in the water become too high, scale forms inside the heat exchanger tubes, reducing heater efficiency and also damaging the heater. If the pH drops below 7.2, the heater will be severely damaged. This will result in corrosion of the heat exchanger. **Heat exchanger damage resulting from chemical imbalance is not covered by the warranty.**

Element Inspection and Replacement

The element assembly head is removed as follows:

1. Turn off electrical power to heater at the main disconnect and turn off water supply line.
2. Drain the heater.
3. Remove access panel.
4. Disconnect all wires to terminals of elements.
5. Remove four bolts holding element in place.
6. Remove element assembly.
7. Replace element assembly and gasket using reverse procedure.

Removing the Aquastat

1. Turn off electrical power to heater at main disconnect.
2. Remove screw holding aquastat to mounting plate.
3. Disconnect wires from aquastat and control knob.

-
4. Remove retainer clip at bulb and remove capillary bulb.
 5. Remove aquastat, using extreme care to see that the capillary tube is not kinked or broken. (Never use anything but fingers to bend capillary tubing).

Removing the High Limit

1. Turn off electrical power to heater at main disconnect.
2. Disconnect wires from high limit.
3. Remove screws holding high limit to tank.

Removing the Pressure Switch

1. Turn off electrical power to heater at main disconnect.
2. Drain heater.
3. Disconnect pressure switch leads.
4. Unscrew pressure switch.

Removing the Magnetic Contactor

1. Turn off electric power to heater at main disconnect.
2. Remove wires from contactor.
3. Remove screw holding contactor to cabinet.

Winterizing

Damage will occur if water is allowed to freeze inside the heater. Normally the heater will drain when the spa is drained. If the heater is positioned lower than the spa a drain valve must be added at the heater inlet. The water must be drained from the heater and the main disconnect switch shut off.

Filter

CAUTION: Do not allow filter to become clogged to the extent that cycling of the pressure switch occurs. This can result in accelerated wear of the magnetic contactor. Contactor damage caused by dirty filter is not covered by warranty.

TROUBLESHOOTING

Problem	Cause	Solution
Nothing happens when the thermostat is turned on	Low flow..... High limit..... Thermostat not calling for heat.....	1. Check filter, skimmer basket, pump. 2. If a 2-speed pump is used, turn to high speed. If heater operates, adjust pressure switch for low speed operation. Push reset button. Turn thermostat to higher temperature.
It takes a long time to heat the spa	Low input voltage..... Undersized heater..... Heat loss from poor weather conditions (cold, high winds)..... Defective heating element.....	Call electric company. Calculate temperature in Heat rise °/hr.= Heater input (kw) x 410 divided by spa gallonage (This does not take into account heat loss due to weather). Use spa cover. Call electrician. Check resistance/element bundle: 240V 11 kw = 5.0 to 5.8 OHMS 240V 5.5 kw = 10.0 to 11.6 OHMS
Spa does not reach temperature	Mis-adjusted knob-stop..... Low flow.....	Re-adjust knob-stop. Check filter, skimmer basket, pump.
Heating element continuously burning out	High input voltage..... Poor water chemistry..... Heating element split open.....	Call electric company. See Water Chemistry on page 11. Over-acid condition. Watch pH, add acid slowly.
Continuous shutdown of manual reset high limit	Mis-adjusted or defective pressure switch.....	Replace pressure switch.
Fuses blow or circuit breaker opens	Shorted heating elements..... Undersized wire.....	Replace element. Replace wire.
Contactor hum	Circuit breaker or fuses too small.. Contactor contacts dirty or worn.... (NOTE: Some hum is normal)	Replace. Replace contactor.
Contactor chatter	Low flow.....	Check filter skimmer basket and pump.

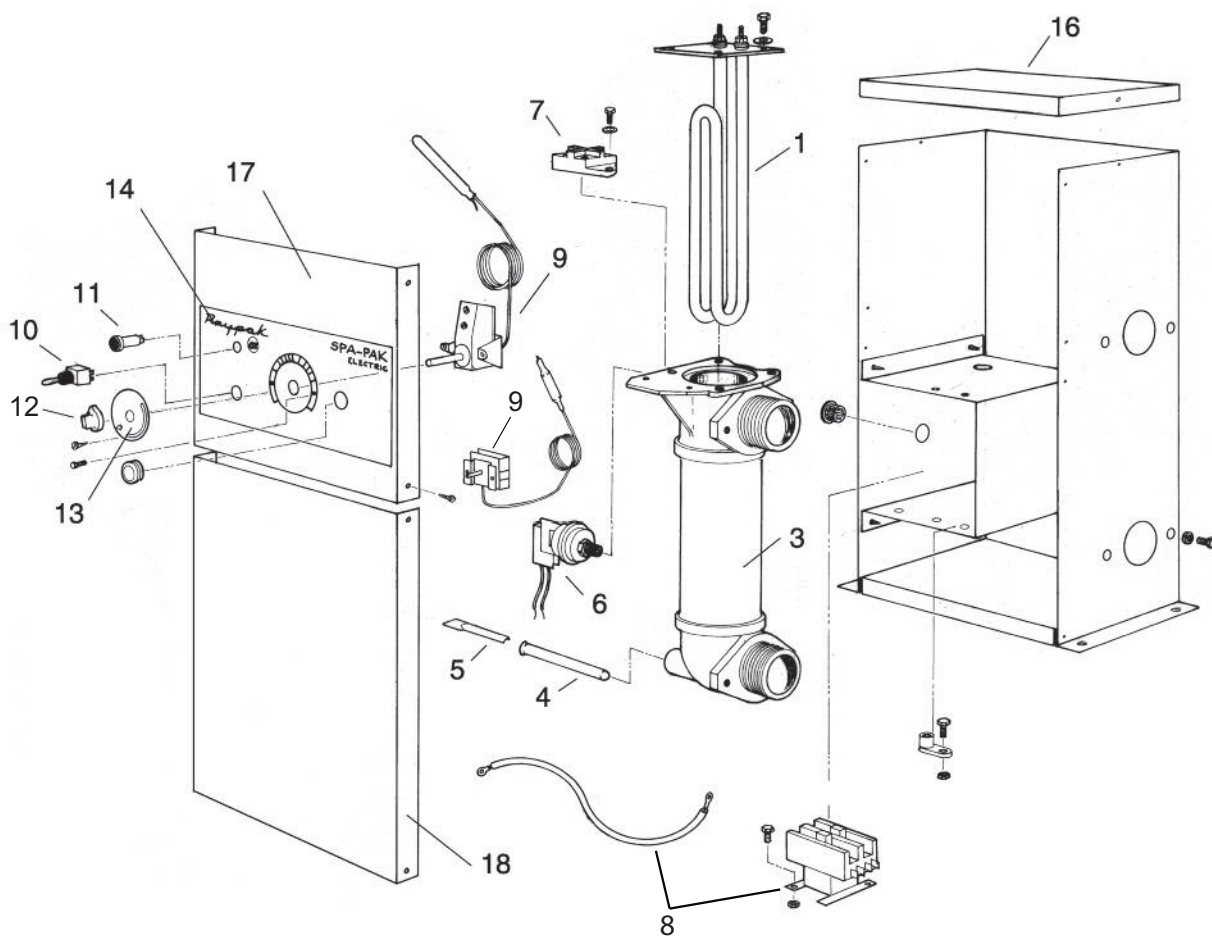

	PART DESCRIPTION	ELS 552-2	ELS 1102-2
1	Element	001801F	001802F
2	Element Gasket (Not Shown)	800164	800164
3	Element Tube Assy.	001805F	001808F
4	Sensor Well	004087F	004087F
5	Well Retaining Clip	300203	300203
6	Pressure Switch	062237B	062237B
7	High Limit	001811F	001811F
8	Contactor/Wire Kit	001813F	001813F
9	Thermostat Control	003346F	003346F
10	Toggle Switch	650761	650761
11	Indicator Light	001812F	001812F
12	Knob	006885F	006885F
13	Knobstop	006886F	006886F
14	Dial Plate	900615	900615
15	Wire Kit (Complete)	N/A	N/A
16	Jacket Top	N/A	N/A
17	Upper Front Panel	N/A	N/A
18	Lower Front Panel	N/A	N/A



www.raypak.com

Raypak, Inc., 2151 Eastman Avenue, Oxnard, CA 93030 (805) 278-5300 Fax (805) 278-5468
Litho in U.S.A.