



The new degree of comfort.™

SUBMITTAL COVER SHEET

PROJECT NAME _____

LOCATION _____

ARCHITECT _____

ENGINEER _____

CONTRACTOR _____

SUBMITTED BY _____ DATE _____

UNIT SUMMARY

Quantity						
Unit Designation						
Model No.						
Total Cooling						
Sensible Cooling						
Air Ent. Evaporator						
Air Lvg. Evaporator						
Heating Input						
Heating Output						
CFM/ESP						
EER/SEER						
Electrical						
Minimum Ampacity						
Min.-Max. Breaker						
Net Unit Weight						
Accessory						
Catalog Form Number						

ACCESSORIES:

NOTES:



INTEGRATED HOME COMFORT

MULTI POSITION GAS FURNACES

R96P Series

96% A.F.U.E.†

Input Rates 40 to 115 kBTU [11.72 to 33.71 kW]

JOB NAME _____ MODEL NO. _____
 CONTRACTOR _____ OUTDOOR UNIT MODEL NO. _____
 ENGINEER _____ LOCATION _____
 SUBMITTED FOR APPROVAL RECORD ORDER NO. _____
 DATE _____

UNIT DATA

HEATING PERFORMANCE

TOTAL CAPACITY INPUT* MBH [kW]
 TOTAL CAPACITY OUTPUT* MBH [kW]
 DESIGN TEMP. RISE °F [°C] DB
 AFUE %
 CALIFORNIA SEASONAL EFFICIENCY %
(*uses blower motor heat)

SUPPLY AIR BLOWER PERFORMANCE

TOTAL AIR SUPPLY CFM [L/s]
 TOTAL RESISTANCE EXTERNAL TO UNIT IWG
 BLOWER SPEED RPM
 POWER OUTPUT REQUIREMENT BHP
 MOTOR RATING HP [W]
 POWER INPUT REQUIREMENT kW

ELECTRICAL DATA

POWER SUPPLY Hz
 TOTAL UNIT AMPACITY AMPS
 MINIMUM WIRE SIZE AWG
 MAXIMUM OVERCURRENT DEVICE FUSES/HACR BREAKER AMPS

FEATURES FOR R96P

- Up to 96% residential gas furnace CSA certified
- 4 way multi-poise design
- Two stages of operation to save energy and maintain optimal comfort level.
- PlusOne™ Diagnostics 7-Segment LED all units
- PlusOne™ Ignition System – DSI for reliability and longevity
- PlusOne™ Water Management System with patented Blocked Drain Sensor
- Heat exchanger is removable for improved serviceability. Primary is constructed of aluminized steel, secondary is constructed of stainless steel, for maximum corrosion resistance and thermal fatigue reliability.
- Low profile “34 inch” cabinet ideal for space constrained installations.
- Blower Shelf design – serviceable in all furnace orientations
- Pre marked hoses – insures proper system drainage
- Vent with 2" or 3" PVC
- Replaceable Collector box
- Hemmed edges on cabinet and doors
- Solid bottom included
- Quarter turn fasteners for tool less access
- Integrated control boards feature dip switches for easy system set up
- Self priming condensate trap

†A.F.U.E. (Annual Fuel Utilization Efficiency) calculated in accordance with Department of Energy test procedures.

FIELD INSTALLED ACCESSORIES

- Vent Termination Kits Concentric:
 Vertical/Horizontal = RXGY-E03A-E02A (US & Canadian Installations)
- Combustion Air Drain Kit
 RXGY-D05, RXGY-D06
- Neutralizer Kit: RXGY-A01
- Fossil Fuel Kit: RXPF-F01 and F02
- External Bottom Filter Rack RXGF-CB
- External Side Filter Rack RXGF-CD
- External (Downflow) Filter Rack RXGF-CC



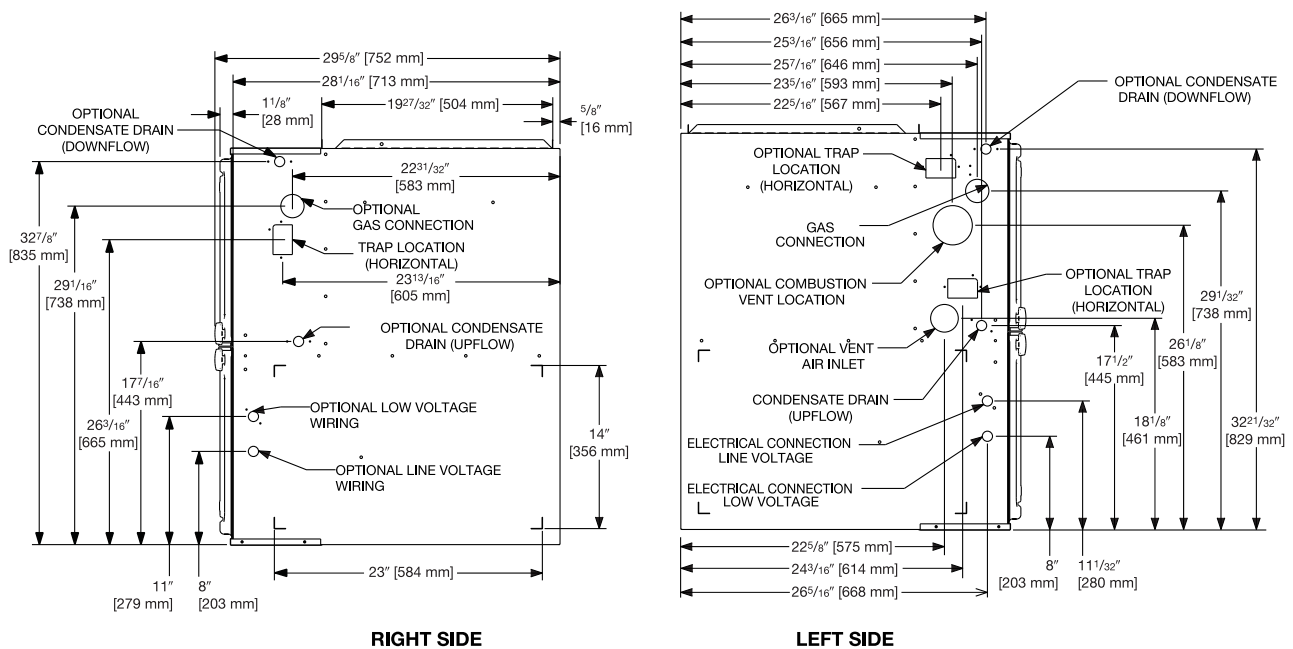
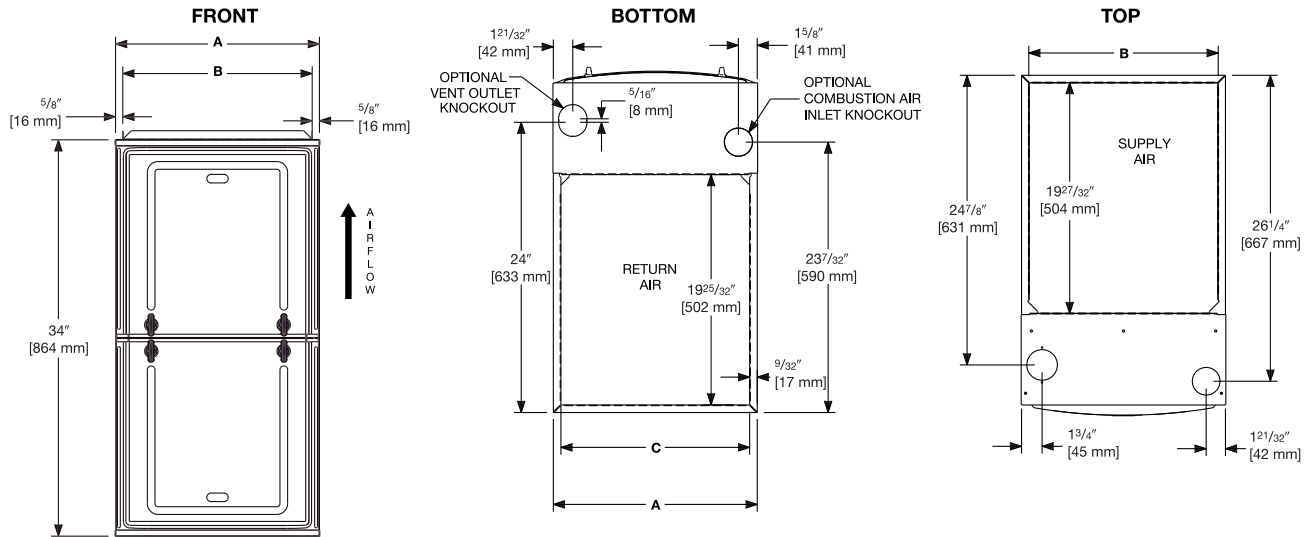

UNIT DIMENSIONS (CLEARANCE TO COMBUSTIBLES)

MODEL R96P	LEFT SIDE	MINIMUM CLEARANCE (IN.) [mm]					SHIP WGTs. (LBS.) [kg]	FLANGE DIMENSIONS		
		RIGHT SIDE	BACK	TOP	FRONT	VENT		A	B	C
040	0	0	0	1 [25]	2 [51]	0	123 [56]	17 1/2 [445]	16 17/64 [413]	16 13/64 [412]
060	0	0	0	1 [25]	2 [51]	0	128 [58]	17 1/2 [445]	16 17/64 [413]	16 13/64 [412]
070	0	0	0	1 [25]	2 [51]	0	132 [60]	17 1/2 [445]	16 17/64 [413]	16 13/64 [412]
085	0	0	0	1 [25]	2 [51]	0	147.5 [67]	21 [533]	19 49/64 [502]	19 45/64 [500]
100	0	0	0	1 [25]	2 [51]	0	152 [69]	21 [533]	19 49/64 [502]	19 45/64 [500]
115	0	0	0	1 [25]	2 [51]	0	165 [75]	24 1/2 [622]	23 17/64 [591]	23 13/64 [589]

*A service clearance of at least 24" is recommended in front of all furnaces
 Supply and return depicted as upflow configuration.
 Flange configuration will vary depending on installation orientation.

[] Designates Metric Conversions

Before proceeding with installation, refer to installation instructions packaged with each model, as well as complying with all Federal, State, Provincial, and Local codes, regulations, and practices.

"In keeping with its policy of continuous progress and product improvement, Manufacturer reserves the right to make changes without notice."