



RELY ON RUUD.™

# SUBMITTAL COVER SHEET

PROJECT NAME \_\_\_\_\_  
LOCATION \_\_\_\_\_  
ARCHITECT \_\_\_\_\_  
ENGINEER \_\_\_\_\_  
CONTRACTOR \_\_\_\_\_  
SUBMITTED BY \_\_\_\_\_ DATE \_\_\_\_\_

## UNIT SUMMARY

Quantity						
Unit Designation						
Model No.						
Total Cooling						
Sensible Cooling						
Air Ent. Evaporator						
Air Lvg. Evaporator						
Heating Input						
Heating Output						
CFM/ESP						
EER/SEER						
Electrical						
Minimum Ampacity						
Min.-Max. Breaker						
Net Unit Weight						
Accessory						
Catalog Form Number						

**ACCESSORIES:**

**NOTES:**

# SUBMITTAL SHEET FOR PACKAGE GAS ELECTRIC RGEA15 SERIES, Nominal Sizes 2-5 Tons [7.0-17.6 kW]

JOB NAME \_\_\_\_\_  
 CONTRACTOR \_\_\_\_\_  
 ENGINEER \_\_\_\_\_  
 LOCATION \_\_\_\_\_  
 ORDER NO. \_\_\_\_\_  
 SUBMITTED FOR  APPROVAL  RECORD  
 SUBMITTED BY \_\_\_\_\_  
 DATE \_\_\_\_\_  
 UNIT DESIGNATION \_\_\_\_\_  
 MODEL NO. \_\_\_\_\_

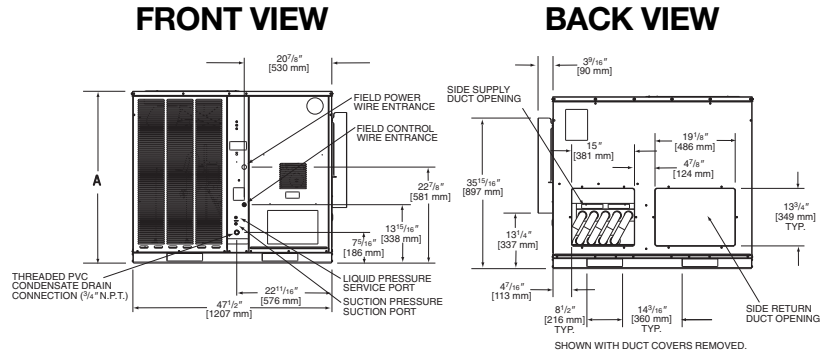

## SIDE VIEW

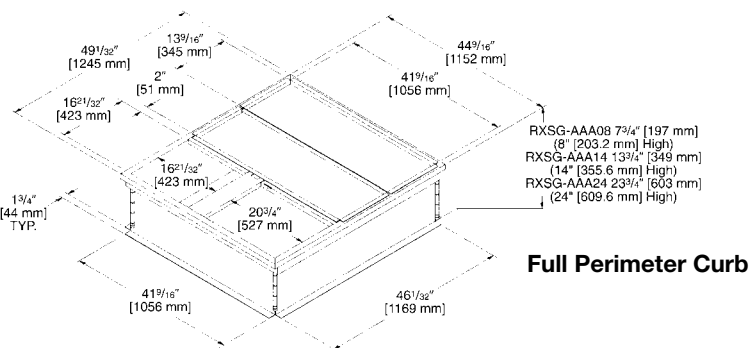
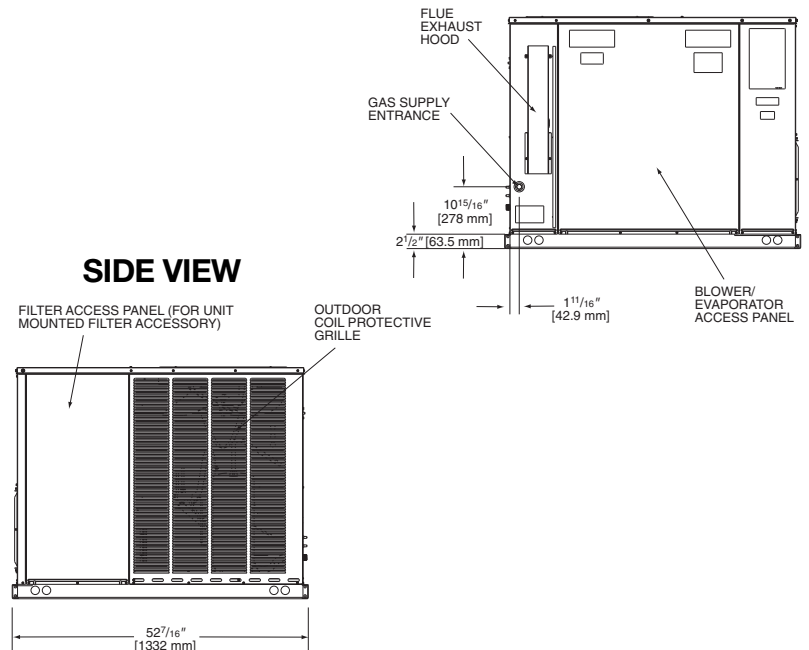

## UNIT DATA

### COOLING PERFORMANCE

TOTAL CAPACITY\* ..... MBH  
 SENSIBLE CAPACITY\* ..... MBH  
 OUTDOOR DESIGN TEMP. ... °F [°C] DB/WB  
 TOTAL SUPPLY AIR ..... CFM [L/s]  
 TEMP. OF AIR ENTERING  
 EVAPORATOR COIL ..... °F [°C] DB/WB  
 POWER INPUT REQUIREMENT ..... kW  
 SEER/EER RATING .....  
 (\*uses blower motor heat)

### HEATING PERFORMANCE

GAS HEAT INPUT CAPACITY ..... MBH  
 GAS HEAT OUTPUT CAPACITY ..... MBH  
 STEADY STATE EFFICIENCY .....

### SUPPLY AIR BLOWER PERFORMANCE

TOTAL SUPPLY AIR ..... CFM [L/s]  
 TOTAL RESISTANCE EXTERNAL  
 TO UNIT ..... IWG  
 BLOWER SPEED ..... RPM  
 POWER OUTPUT REQUIREMENT .... BHP  
 MOTOR RATING ..... HP [W]  
 POWER INPUT REQUIREMENT ..... kW

### ELECTRICAL DATA

POWER SUPPLY ..... Hz  
 TOTAL UNIT AMPACITY ..... AMPS  
 MINIMUM WIRE SIZE ..... AWG  
 MAXIMUM OVERCURRENT DEVICE  
 FUSES HACR BREAKER ..... AMPS

### TOTAL UNIT WEIGHT

TOTAL OPERATING WEIGHT ..... LBS [kg]  
 (including field-installed accessories)

### CLEARANCES

FRONT	48" [1219 mm]
CONDENSER COIL	18" [457 mm]
DUCT SIDE	12" [305 mm]
EVAPORATOR END	36" [914 mm]
ABOVE UNIT	60" [1524 mm]

[ ] Designates Metric Conversions

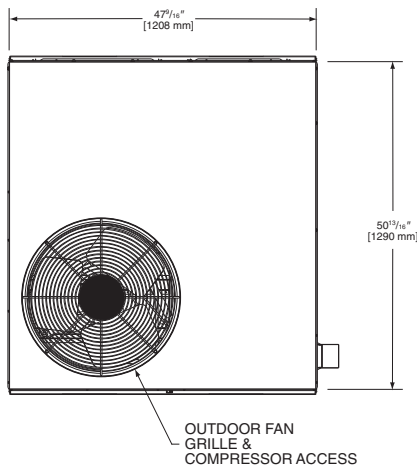

**TOP VIEW**

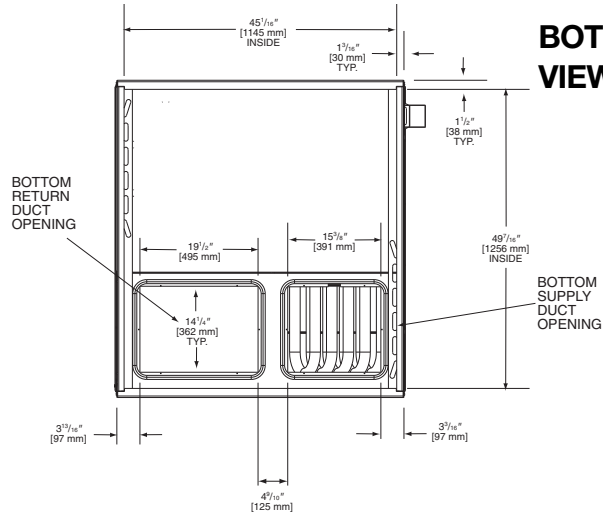

**BOTTOM VIEW**

[ ] Designates Metric Conversions

**FEATURES**

1. All models feature Scroll® compressors for maximum efficiency and quiet operation. 5 Ton RGEA15 models feature UltraTech™ Scroll 2-Stage compressors with Comfort Alert™ diagnostics (see below), high/low pressure switches, and hard start kits.
2. Louvered condenser compartment for protecting the coil against yard hazards and/or weather extremes.
3. One-piece top with a deep flange to help keep water out of the unit.
4. Supply and return air openings feature a one-inch tall flange to prevent water migration into the ductwork.
5. Access panels have “weep holes” and channels to further help manage water run-off.
6. Side and down discharge options available on all models. All models are shipped ready for horizontal application.
7. Easily accessible blower section complete with slide-out blower. The RGEA15 comes standard with variable speed motor with adjustable airflow in heating and cooling. The variable speed motor also comes with a interface that allows for dehumidification when used in continuous humidistat. The variable speed system is capable of 1 inch external static.
8. Refrigerant connections are conveniently located for easy service diagnostics.
9. Condenser and evaporator coils feature enhanced fins for better heat transfer and rifled copper tubing for greater efficiency.
10. Inside the easily accessible furnace compartment is the draft inducer motor. This motor is specially designed for quiet reliable operation. In addition to the draft inducer motor, the in-shot gas burners and manifold efficiently regulate the flow of gas for combustion. These new gas/electric units also feature direct-spark ignition and remote flame sensors for added reliability and efficiency.
11. All units feature an internal trap on the condensate line eliminating the need for installing an on-site external trap.
12. Easily accessible control box.
13. Single point wiring simplifies installation.
14. Our gas/electric package units feature a tubular heat exchanger design. Tubular heat exchangers are more efficient and durable than older-style clamshell heat exchangers.
15. Thermal expansion valve standard on all models for superior superheat control, reliability, and energy efficiency at all operating conditions.
16. Filter drier standard on all models (not shown).
17. Rugged baserail included for improved installation and handling
18. Complete factory charged, wired and run tested.
19. Molded compressor plugs.

**FIELD INSTALLED ACCESSORIES**

- Roof Curb (8" [203.2 mm], 14" [355.6 mm] & 24" [609.6 mm] High Full Platform).....
- Roof Curb (14" [355.6 mm] & 24" [609.6 mm] Sloped Platform) .....
- Filter Accessory .....
- Lift Kit (For Rigging) .....
- Time Delay Relay.....
- Start Assist .....
- Low Ambient Control .....

- Low Pressure Control .....
- Economizer (Enthalpy Controlled) Downflow Only.....
- Manual Fresh Air Damper .....
- L.P. (Propane) Kit .....
- Transition (Rectangular-Round) Downflow/Sideflow .....
- Concentric Diffuser and Grille .....
- High Pressure Control .....
- Thermostat .....

**Before proceeding with installation, refer to installation instructions packaged with each model, as well as complying with all Federal, State, Provincial, and Local codes, regulations, and practices.**

Rheem Sales Company, Inc.  
P.O. Box 17010, Fort Smith, AR 72917

*"In keeping with its policy of continuous progress and product improvement, Rheem reserves the right to make changes without notice."*