



Real People. Real Savings. Real Fast.®

# SUBMITTAL COVER SHEET

PROJECT NAME \_\_\_\_\_

LOCATION \_\_\_\_\_

ARCHITECT \_\_\_\_\_

ENGINEER \_\_\_\_\_

CONTRACTOR \_\_\_\_\_

SUBMITTED BY \_\_\_\_\_ DATE \_\_\_\_\_

## UNIT SUMMARY

|                     |  |  |  |  |  |  |
|---------------------|--|--|--|--|--|--|
| Quantity            |  |  |  |  |  |  |
| Unit Designation    |  |  |  |  |  |  |
| Model No.           |  |  |  |  |  |  |
| Total Cooling       |  |  |  |  |  |  |
| Sensible Cooling    |  |  |  |  |  |  |
| Air Ent. Evaporator |  |  |  |  |  |  |
| Air Lvg. Evaporator |  |  |  |  |  |  |
| Heating Input       |  |  |  |  |  |  |
| Heating Output      |  |  |  |  |  |  |
| CFM/ESP             |  |  |  |  |  |  |
| EER/SEER            |  |  |  |  |  |  |
| Electrical          |  |  |  |  |  |  |
| Minimum Ampacity    |  |  |  |  |  |  |
| Min.-Max. Breaker   |  |  |  |  |  |  |
| Net Unit Weight     |  |  |  |  |  |  |
| Accessory           |  |  |  |  |  |  |
| Catalog Form Number |  |  |  |  |  |  |

**ACCESSORIES:**

**NOTES:**

# SUBMITTAL SHEET FOR SP15

## 1 1/2 TO 5 NOMINAL TON [5.28 TO 17.6 kW], EFFICIENCIES: 14-15 SEER/11.5-12.5 EER HEAT PUMPS

JOB NAME \_\_\_\_\_ LOCATION \_\_\_\_\_

CONTRACTOR \_\_\_\_\_ ORDER NO. \_\_\_\_\_

ENGINEER \_\_\_\_\_ UNIT MODEL NO. \_\_\_\_\_

SUBMITTED FOR       APPROVAL       RECORD      COIL MODEL NO. \_\_\_\_\_

DATE \_\_\_\_\_ AIR HANDLER MODEL NO. \_\_\_\_\_

### UNIT DATA

#### COOLING PERFORMANCE

EFFICIENCY ..... SEER

TOTAL CAPACITY\* ..... MBH [kW]

SENSIBLE CAPACITY\* ..... MBH [kW]

OUTDOOR DESIGN TEMP ..... °F [°C] DB

TEMP. OF AIR ENTERING  
EVAPORATOR COIL ..... °F [°C] DB

..... °F [°C] WB

POWER INPUT REQUIREMENT ..... kW  
(\*uses blower motor heat)

#### HEATING PERFORMANCE

EFFICIENCY ..... HSPF

TOTAL CAPACITY\* ..... MBH [kW]

OUTDOOR DESIGN TEMP ..... °F [°C] DB

TEMP. OF AIR ENTERING  
EVAPORATOR COIL ..... °F [°C] DB

#### SUPPLY AIR BLOWER PERFORMANCE

TOTAL AIR SUPPLY ..... CFM [L/s]

TOTAL RESISTANCE EXTERNAL  
TO UNIT ..... IWG

BLOWER SPEED ..... RPM

POWER OUTPUT REQUIREMENT ..... BHP

MOTOR RATING ..... HP [W]

POWER INPUT REQUIREMENT ..... kW

#### ELECTRICAL DATA

POWER SUPPLY ..... Hz

TOTAL UNIT AMPACITY ..... AMPS

MINIMUM WIRE SIZE ..... AWG

MAXIMUM OVERCURRENT DEVICE  
FUSES/HACR BREAKER ..... AMPS

#### CLEARANCES

ACCESS SIDE ..... 24" [609.6 mm]

AIR INLETS ..... 12" [304.8 mm]

ABOVE UNIT ..... 60" [1524 mm]

### FEATURES FOR SP15 HEAT PUMP UNITS

- New composite base pan – dampens sound, secures wire grille, eliminates corrosion and reduces number of fasteners needed
- Improved tubing design – reduces vibration and stress, making unit quieter and reducing opportunity for leaks
- Optimized defrost characteristics - decrease defrosting and provide better home comfort
- Powder coat paint finish – for a long lasting professional finish
- Optimized reversing valve sizing – improves shifting performance for quieter unit operation and increased life of the system
- Enhanced mufflers – help to dissipate vibration energy for quieter unit operation
- Scroll compressor – a sound abating feature added to the compressor significantly reduces noise when system transitions in and out of defrost mode
- Modern cabinet aesthetics – increased curb appeal with visually appealing design
- Wire grille – provide ultimate coil protection, enhance cabinet strength, and increased cabinet rigidity
- Optimized fan orifice – optimizes airflow and reduces unit sound
- Rust resistant screws – confirmed through 1500-hour salt spray testing
- 3"-4"-5" service valve space – provides a minimum working area of 27-square inches for easier access
- Integrated heat pump lift receptacle – allows standard CPVC stands to be inserted into the base
- 15" wide, industry leading corner service access – makes repairs easier and faster.
- External gauge port access – allows easy connection of "low-loss" gauge ports
- Single-row condenser coil – makes unit lighter and allows thorough coil cleaning to maintain "out of the box" performance
- Fewer cabinet fasteners and fastener-free base – allow for faster access to internal components and hassle-free panel removal
- Service trays – hold fasteners or caps during service calls
- QR code – provides technical information on demand for faster service calls
- Fan motor harness with extra-long wires – allows unit top to be removed without disconnecting fan wire

### ACCESSORIES/OPTIONS

- Compressor Crankcase Heater .....
- Low Ambient Control (Model No. RXAD-A08) .....
- Compressor Sound Cover .....
- Compressor Hard Start Kit .....
- Classic Top Cap w/label (91-101123-21) .....
- Low Pressure Control (RXAC-A07) .....
- High Pressure Control (RXAB-A07) .....
- Heat Pump Riser 6 in. (686020) .....



(IN CERTAIN MATCHED SYSTEMS)

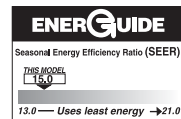

**SP15 18, 24, 30,  
36, 42, 48, 60**

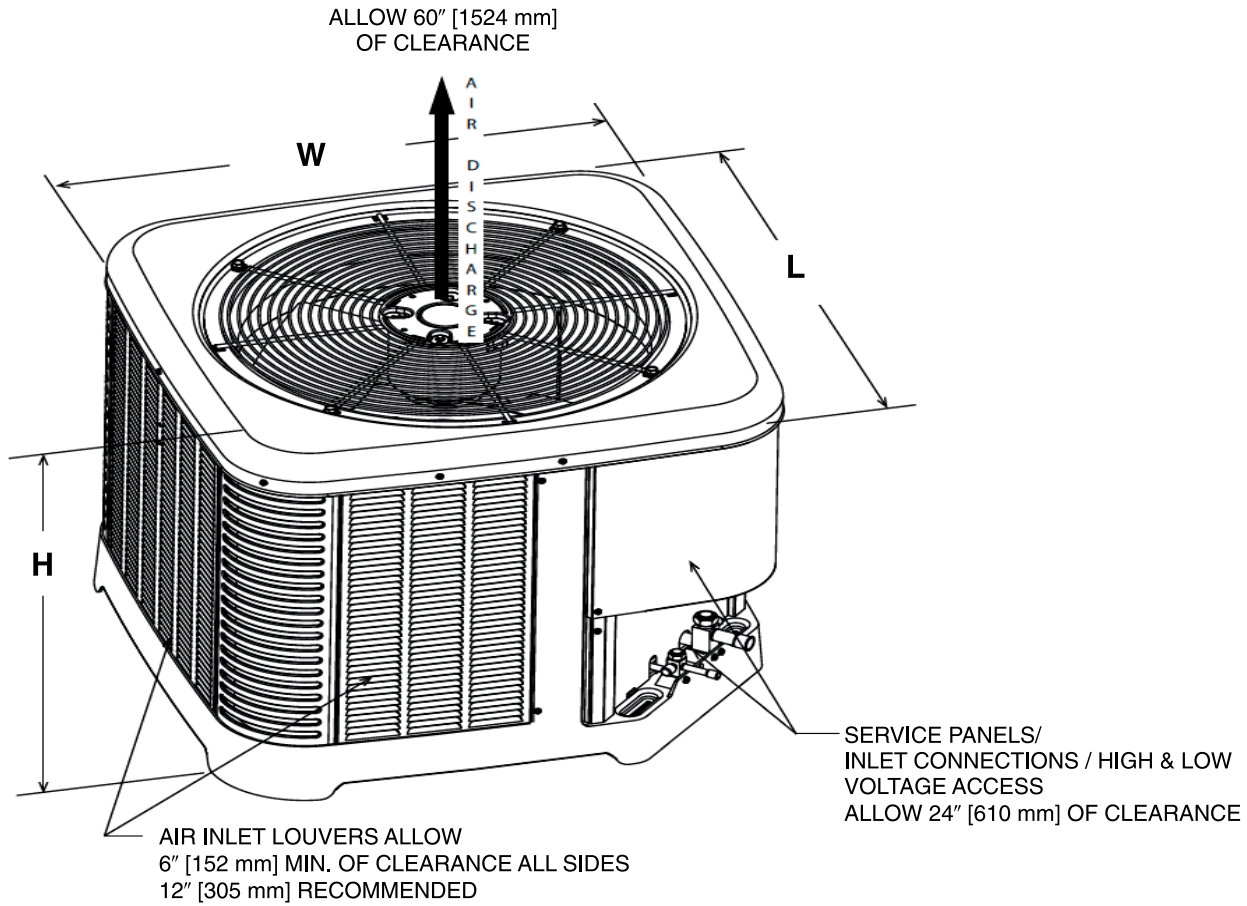

ST-A1226-02-00

## Unit Dimensions

| MODEL NUMBER | OPERATING  |      |            |     |           |     | SHIPPING   |      |            |     |           |     |
|--------------|------------|------|------------|-----|-----------|-----|------------|------|------------|-----|-----------|-----|
|              | H (Height) |      | L (Length) |     | W (Width) |     | H (Height) |      | L (Length) |     | W (Width) |     |
|              | INCHES     | mm   | INCHES     | mm  | INCHES    | mm  | INCHES     | mm   | INCHES     | mm  | INCHES    | mm  |
| SP1518       | 25         | 635  | 29.75      | 755 | 29.75     | 755 | 26.75      | 679  | 32.38      | 822 | 32.38     | 822 |
| SP1524       | 25         | 635  | 29.75      | 755 | 29.75     | 755 | 26.75      | 679  | 32.38      | 822 | 32.38     | 822 |
| SP1530       | 31         | 787  | 33.75      | 857 | 33.75     | 857 | 32.75      | 831  | 32.38      | 822 | 32.38     | 822 |
| SP1536       | 35         | 889  | 33.75      | 857 | 33.75     | 857 | 36.75      | 933  | 36.38      | 924 | 36.38     | 924 |
| SP1542       | 35         | 889  | 33.75      | 857 | 33.75     | 857 | 36.75      | 933  | 36.38      | 924 | 36.38     | 924 |
| SP1548       | 39         | 990  | 35.75      | 908 | 35.75     | 908 | 40.75      | 1035 | 38.38      | 974 | 38.38     | 974 |
| SP1560       | 45         | 1143 | 35.75      | 908 | 35.75     | 908 | 46.75      | 1187 | 38.38      | 974 | 38.38     | 974 |

[ ] Designates Metric Conversions

Before proceeding with installation, refer to installation instructions packaged with each model, as well as complying with all Federal, State, Provincial, and Local codes, regulations, and practices.

Sure Comfort® Heating and Cooling  
P.O. Box 17010, Fort Smith, AR 72917

"In keeping with its policy of continuous progress and product improvement, Sure Comfort® reserves the right to make changes without notice."