

INSTALLATION OPERATION AND MAINTENANCE INSTRUCTIONS

IOM 115

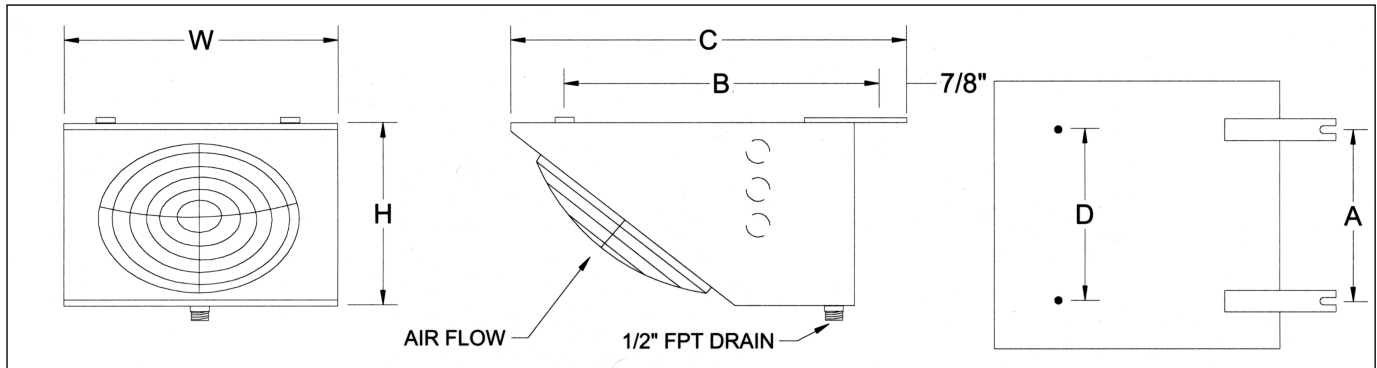

DIMENSIONS (IN)

MODEL	A	B	C	D	F	H	W	Liquid Conn.	Suction Conn.	Weight (lbs.)
WE 17-12	12-3/4	13-5/8	15-13/16	11-7/16	1-1/4	8-5/16	15-1/4	1/2 FN	1/2 OD	16
WE 17-15	12-3/4	13-5/8	15-13/16	11-7/16	1-1/4	8-5/16	15-1/4	1/2 FN	1/2 OD	19
WE 17-18	15-3/4	13-5/8	15-13/16	14-1/2	1-1/4	8-5/16	17-3/4	1/2 FN	1/2 OD	22
WE 17-25	18-3/4	14-5/8	16-13/16	17-1/2	1-1/4	8-5/16	19-7/8	1/2 FN	1/2 OD	29
WE 17-35	21-3/4	15-5/8	17-7/8	20-1/2	1-1/4	9-1/2	22-7/8	1/2 FN	1/2 OD	36
WE 17-45	24-3/4	15-5/8	20-1/2	23-5/8	1-7/8	9-5/8	26-3/4	1/2 FN	1/2 OD	57
WE 18-55	24-3/4	15-5/8	20-1/2	23-5/8	1-7/8	9-5/8	26-3/4	1/2 FN	1/2 OD	65



GENERAL

RECEIPT AND EXAMINATION

Carefully check all items against bill of lading to be sure everything has been received as ordered. Carefully inspect all items for damage and, if any is found, report it immediately to the carrier and file damage claim with same.

INSTALLATION

LOCATION AND MOUNTING

The WE is designed to mount on ceiling only. The unit should be installed so that there are no restrictions on the air inlet or outlet as this will cause the refrigeration system to operate less efficiently.

Remove the unit from the carton. Using the fastener holes in the unit as a guide, locate the mounting fasteners in the ceiling of the walk-in or reach-in cooler. Use #10 screws or 1/4" diameter bolts to secure the unit to the ceiling. This unit must be installed so as to allow drainage of condensate coming off the coil.

The National Sanitation Foundation (NSF) requires that any flush mounted unit be properly and completely sealed, with an approved NSF sealant, between the unit and the mounting surface.

ELECTRICAL

System electrical installation should conform to all applicable codes and practices. All models will require the connection of power to the fan motor according to the nameplate motor circuit electrical ratings.

REPLACEMENT PARTS

To order replacement parts, contact your local representative or contact the factory (800) 288-9488 for the location of the nearest HTP wholesaler. Always provide the evaporator model number, serial number, unit voltage and a complete description of the part required.

Coil Model Number	FAN MOTOR			FAN BLADE			FAN GUARD		DRAIN PAN
	MOTOR HP	MOTOR RPM	PART NUMBER	BORE	DESCRIPTION	PART NUMBER	DIA.	PART NUMBER	PART NUMBER
WE 17-12	4 Watt	1550	102104002	1/4"	831 CCW	204395010	8"	206569000	20193200
WE 17-15	9 Watt	1550	103104004	1/4"	831 CCW	204395010	8"	206569000	20193200
WE 17-18	9 Watt	1550	103104004	1/4"	831 CCW	204395010	8"	206569000	20193000
WE 17-25	9 Watt	1550	103104004	Hubless	1020 CCW	204395016	8"	201006002	20192600
WE 17-35	16 Watt	1550	103104007	1/4"	1031 CCW	204395018	10"	201006002	20192400
WE 17-45	1/20	1550	102540001	5/16	1219 CCW	11860	12"	201006003	20194000
WE 18-55	1/20	1550	102540001	5/16	1219 CCW	11860	12"	201006003	20194000