



Real People. Real Savings. Real Fast.®

# SUBMITTAL COVER SHEET

PROJECT NAME \_\_\_\_\_

LOCATION \_\_\_\_\_

ARCHITECT \_\_\_\_\_

ENGINEER \_\_\_\_\_

CONTRACTOR \_\_\_\_\_

SUBMITTED BY \_\_\_\_\_ DATE \_\_\_\_\_

## UNIT SUMMARY

Quantity						
Unit Designation						
Model No.						
Total Cooling						
Sensible Cooling						
Air Ent. Evaporator						
Air Lvg. Evaporator						
Heating Input						
Heating Output						
CFM/ESP						
EER/SEER						
Electrical						
Minimum Ampacity						
Min.-Max. Breaker						
Net Unit Weight						
Accessory						
Catalog Form Number						

**ACCESSORIES:**

**NOTES:**

# TWO STAGE MULTI POSITION GAS FURNACE

## S96TA

Input Rates 40 to 115 kBTU [11.72 to 33.71 kW]

JOB NAME \_\_\_\_\_ MODEL NO. \_\_\_\_\_  
 CONTRACTOR \_\_\_\_\_ OUTDOOR UNIT MODEL NO. \_\_\_\_\_  
 ENGINEER \_\_\_\_\_ LOCATION \_\_\_\_\_  
 SUBMITTED FOR  APPROVAL  RECORD ORDER NO. \_\_\_\_\_  
 DATE \_\_\_\_\_

### UNIT DATA

#### HEATING PERFORMANCE

TOTAL CAPACITY INPUT\* ..... \_\_\_\_\_ MBH [kW]  
 TOTAL CAPACITY OUTPUT\* ..... \_\_\_\_\_ MBH [kW]  
 DESIGN TEMP. RISE ..... \_\_\_\_\_ °F [°C] DB  
 AFUE ..... \_\_\_\_\_ %  
 CALIFORNIA SEASONAL EFFICIENCY ..... \_\_\_\_\_ %  
(\*uses blower motor heat)

#### SUPPLY AIR BLOWER PERFORMANCE

TOTAL AIR SUPPLY ..... \_\_\_\_\_ CFM [L/s]  
 TOTAL RESISTANCE EXTERNAL TO UNIT ..... \_\_\_\_\_ IWG  
 BLOWER SPEED ..... \_\_\_\_\_ RPM  
 POWER OUTPUT REQUIREMENT .... \_\_\_\_\_ BHP  
 MOTOR RATING ..... \_\_\_\_\_ HP [W]  
 POWER INPUT REQUIREMENT ..... \_\_\_\_\_ kW

#### ELECTRICAL DATA

POWER SUPPLY ..... \_\_\_\_\_ Hz  
 TOTAL UNIT AMPACITY ..... \_\_\_\_\_ AMPS  
 MINIMUM WIRE SIZE ..... \_\_\_\_\_ AWG  
 MAXIMUM OVERCURRENT DEVICE FUSES/HACR BREAKER ..... \_\_\_\_\_ AMPS

### FEATURES FOR S96TA

- Up to 96% residential gas furnace CSA certified
- 4 way multi-poise design
- Two stages of operation to save energy and maintain optimal comfort level.
- 7-Segment LED all units
- Direct Spark Ignition for reliability and longevity
- Water Management System with patented Blocked Drain Sensor
- Heat exchanger is removable for improved serviceability. Primary is constructed of aluminized steel, secondary is constructed of stainless steel, for maximum corrosion resistance and thermal fatigue reliability.
- Low profile "34 inch" cabinet ideal for space constrained installations.
- Blower Shelf design – serviceable in all furnace orientations
- Pre marked hoses – insures proper system drainage
- Vent with 2" or 3" PVC
- Replaceable Collector box
- Hemmed edges on cabinet and doors
- Solid bottom included
- Quarter turn fasteners for tool less access
- Integrated control boards feature dip switches for easy system set up
- Self priming condensate trap

†A.F.U.E. (Annual Fuel Utilization Efficiency) calculated in accordance with Department of Energy test procedures.

### FIELD INSTALLED ACCESSORIES

- Vent Termination Kits Concentric:  
 Vertical/Horizontal = RXGY-E03A-E02A (US & Canadian Installations) .....
- Combustion Air Drain Kit  
 RXGY-D05, RXGY-D06 .....
- Neutralizer Kit: RXGY-A01 .....
- External Bottom Filter Rack RXGF-CB .....
- External Side Filter Rack RXGF-CD .....
- External (Downflow) Filter Rack RXGF-CC .....



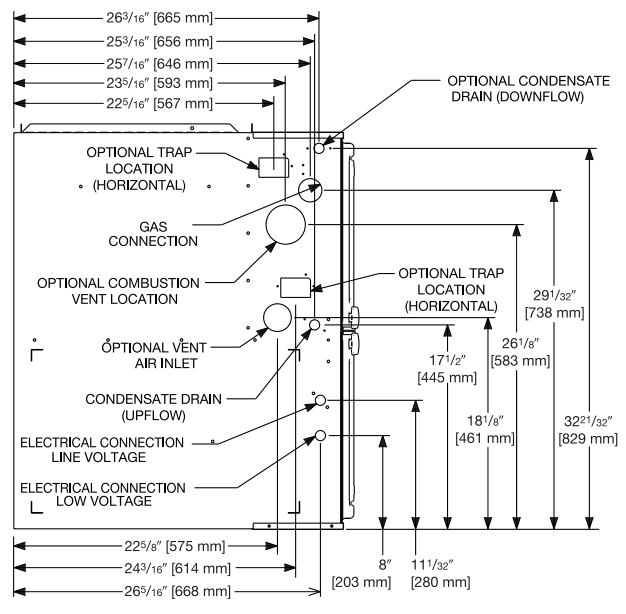
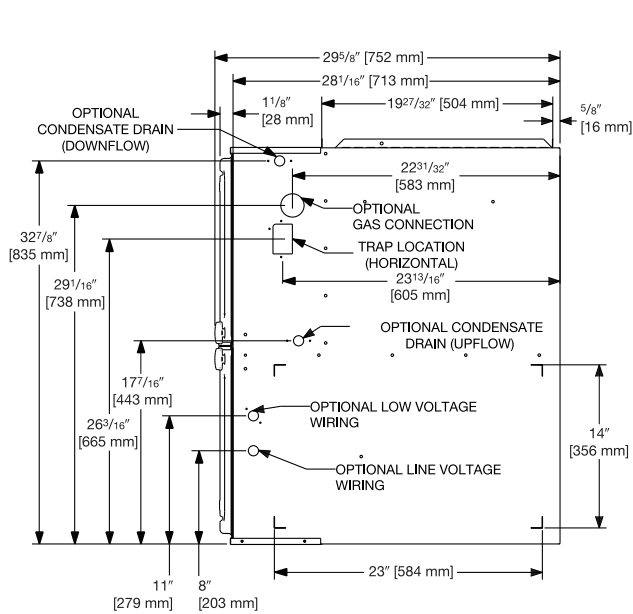
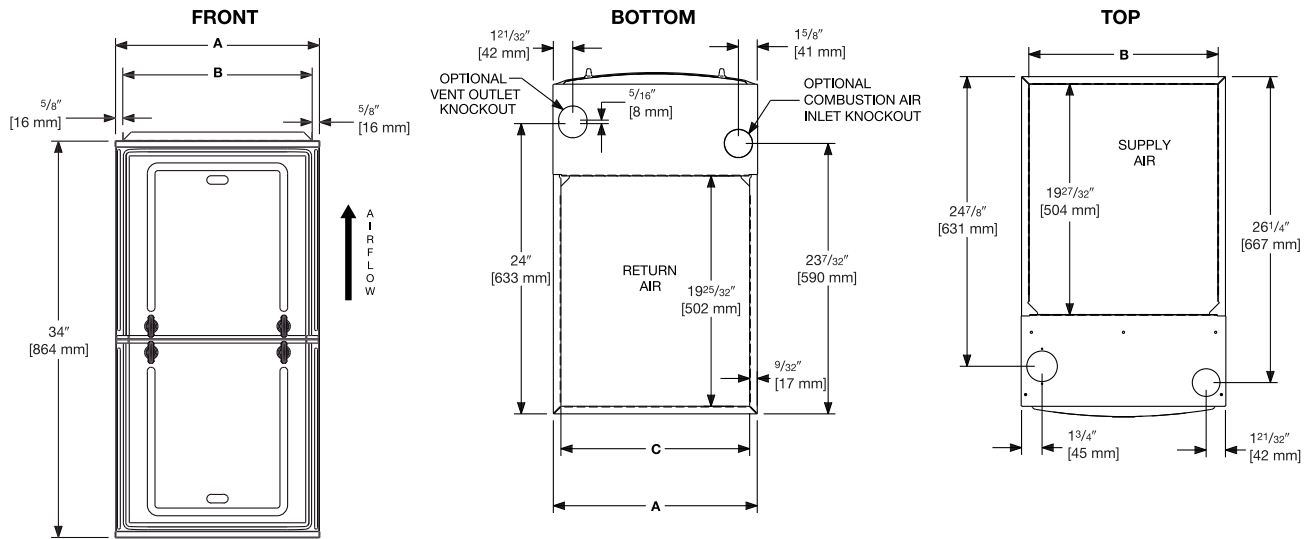

**UNIT DIMENSIONS (CLEARANCE TO COMBUSTIBLES)**

MODEL	LEFT SIDE	MINIMUM CLEARANCE (IN.) [mm]					SHIP WGTs. (LBS.) [kg]	FLANGE DIMENSIONS		
		RIGHT SIDE	BACK	TOP	FRONT	VENT		A	B	C
040	0	0	0	1 [25]	2 [51]	0	123.5 [56]	17 1/2 [445]	16 17/64 [413]	16 13/64 [412]
060	0	0	0	1 [25]	2 [51]	0	128 [58]	17 1/2 [445]	16 17/64 [413]	16 13/64 [412]
070	0	0	0	1 [25]	2 [51]	0	132 [60]	17 1/2 [445]	16 17/64 [413]	16 13/64 [412]
085	0	0	0	1 [25]	2 [51]	0	147.5 [67]	21 [533]	19 49/64 [502]	19 45/64 [500]
100	0	0	0	1 [25]	2 [51]	0	152 [69]	21 [533]	19 49/64 [502]	19 45/64 [500]
115	0	0	0	1 [25]	2 [51]	0	165 [75]	24 1/2 [622]	23 17/64 [591]	23 13/64 [589]

\*A service clearance of at least 24" is recommended in front of all furnaces  
 Supply and return depicted as upflow configuration.  
 Flange configuration will vary depending on installation orientation.

[ ] Designates Metric Conversions

**Before proceeding with installation, refer to installation instructions packaged with each model, as well as complying with all Federal, State, Provincial, and Local codes, regulations, and practices.**

Sure Comfort® Heating and Cooling  
 P.O. Box 17010, Fort Smith, AR 72917

"In keeping with its policy of continuous progress and product improvement, Sure Comfort® reserves the right to make changes without notice."