

# INSTALLATION INSTRUCTIONS

## PACKAGE HEAT PUMPS

RJNL-C 13 SEER SERIES (3-5 TON)

RJNL-C 11.0 EER SERIES (6 TON)

RJPL-C 14 SEER SERIES (3-5 TON)

FEATURING INDUSTRY STANDARD R-410A REFRIGERANT ~~R-410A~~



RECOGNIZE THIS SYMBOL AS AN INDICATION OF IMPORTANT SAFETY INFORMATION!

### WARNING

THESE INSTRUCTIONS ARE INTENDED AS AID TO QUALIFIED, LICENSED SERVICE PERSONNEL FOR PROPER INSTALLATION, ADJUSTMENT AND OPERATION OF THIS UNIT. READ THESE INSTRUCTIONS THOROUGHLY BEFORE ATTEMPTING INSTALLATION OR OPERATION. FAILURE TO FOLLOW THESE INSTRUCTIONS MAY RESULT IN IMPROPER INSTALLATION, ADJUSTMENT, SERVICE OR MAINTENANCE POSSIBLY RESULTING IN FIRE, ELECTRICAL SHOCK, PROPER DAMAGE, PERSONAL INJURY OR DEATH.



ISO 9001:2008  
Certificate Number: 30164

**DO NOT DESTROY THIS MANUAL**

PLEASE READ CAREFULLY AND KEEP IN A SAFE PLACE FOR FUTURE REFERENCE BY A SERVICEMAN



# I. TABLE OF CONTENTS

I. Table of Contents . . . . .	2
II. Safety Information . . . . .	3
III. Introduction . . . . .	5
A. R-410A Refrigerant . . . . .	5
IV. Checking Product Received . . . . .	6
V. Equipment Protection From The Environment . . . . .	6
VI. Installation . . . . .	6
A. General . . . . .	6
B. Outside Slab Installation . . . . .	12
C. Clearances . . . . .	13
D. Rooftop Installation . . . . .	13
VII. Ductwork . . . . .	13
VIII. Filters . . . . .	14
IX. Conversion Procedure . . . . .	14
X. Condensate Drain . . . . .	15
XI. Condensate Drain, Outdoor Coil . . . . .	15
XII. Electrical Wiring . . . . .	15
A. Power Wiring . . . . .	15
B. Special Instructions for Power Wiring with Aluminum Conductors . . . . .	16
C. Control Wiring . . . . .	17
D. Internal Wiring . . . . .	17
E. Grounding . . . . .	17
F. Thermostat . . . . .	17
XIII. Indoor Air Flow Data . . . . .	17
XIV. Room Temperature Sensors . . . . .	18
XV. Crankcase Heat . . . . .	18
XVI. Pre-Start Check . . . . .	18
XVII. Startup . . . . .	18
XVIII. Operation . . . . .	19
XIX. Auxiliary Heat . . . . .	19
A. Control System Operation . . . . .	19
XX. Demand Defrost Control . . . . .	19
XXI. Replacement Parts . . . . .	20
XXII. Charge Information . . . . .	20
XXIII. Troubleshooting . . . . .	20
XXIV. Wiring Diagrams . . . . .	20
XXV. General Data . . . . .	21-29
XXVI. Miscellaneous	
Electrical Data . . . . .	30-35
Indoor Airflow Performance . . . . .	36-38
Heater Kits Characteristics . . . . .	39-46
Wiring Diagram . . . . .	47
Charge Charts . . . . .	48-53
Troubleshooting . . . . .	54

## II. SAFETY INFORMATION

### WARNING

THESE INSTRUCTIONS ARE INTENDED AS AN AID TO QUALIFIED, LICENSED SERVICE PERSONNEL FOR PROPER INSTALLATION, ADJUSTMENT AND OPERATION OF THIS UNIT. READ THESE INSTRUCTIONS THOROUGHLY BEFORE ATTEMPTING INSTALLATION OPERATION. FAILURE TO FOLLOW THESE INSTRUCTIONS MAY RESULT IN IMPROPER INSTALLATION, ADJUSTMENT, SERVICE OR MAINTENANCE POSSIBLY RESULTING IN FIRE, ELECTRICAL SHOCK, PROPERTY DAMAGE, PERSONAL INJURY OR DEATH.

### WARNING

IMPORTANT: ALL MANUFACTURER PRODUCTS MEET CURRENT FEDERAL OSHA GUIDELINES FOR SAFETY. CALIFORNIA PROPOSITION 65 WARNINGS ARE REQUIRED FOR CERTAIN PRODUCTS, WHICH ARE NOT COVERED BY THE OSHA STANDARDS.

CALIFORNIA'S PROPOSITION 65 REQUIRES WARNINGS FOR PRODUCTS SOLD IN CALIFORNIA THAT CONTAIN, OR PRODUCE, ANY OF OVER 600 LISTED CHEMICALS KNOWN TO THE STATE OF CALIFORNIA TO CAUSE CANCER OR BIRTH DEFECTS SUCH AS FIBERGLASS INSULATION, LEAD IN BRASS, AND COMBUSTION PRODUCTS FROM NATURAL GAS.

ALL "NEW EQUIPMENT" SHIPPED FOR SALE IN CALIFORNIA WILL HAVE LABELS STATING THAT THE PRODUCT CONTAINS AND/OR PRODUCES PROPOSITION 65 CHEMICALS. ALTHOUGH WE HAVE NOT CHANGED OUR PROCESSES, HAVING THE SAME LABEL ON ALL OUR PRODUCTS FACILITATES MANUFACTURING AND SHIPPING. WE CANNOT ALWAYS KNOW "WHEN, OR IF" PRODUCTS WILL BE SOLD IN THE CALIFORNIA MARKET.

YOU MAY RECEIVE INQUIRIES FROM CUSTOMERS ABOUT CHEMICALS FOUND IN, OR PRODUCED BY, SOME OF OUR HEATING AND AIR-CONDITIONING EQUIPMENT, OR FOUND IN NATURAL GAS USED WITH SOME OF OUR PRODUCTS. LISTED BELOW ARE THOSE CHEMICALS AND SUBSTANCES COMMONLY ASSOCIATED WITH SIMILAR EQUIPMENT IN OUR INDUSTRY AND OTHER MANUFACTURERS.

- GLASS WOOL (FIBERGLASS) INSULATION
- CARBON MONOXIDE (CO)
- FORMALDEHYDE
- BENZENE

MORE DETAILS ARE AVAILABLE AT THE WEBSITES FOR OSHA (OCCUPATIONAL SAFETY AND HEALTH ADMINISTRATION), AT [WWW.OSHA.GOV](http://WWW.OSHA.GOV) AND THE STATE OF CALIFORNIA'S OEHHA (OFFICE OF ENVIRONMENTAL HEALTH HAZARD ASSESSMENT), AT [WWW.OEHHA.ORG](http://WWW.OEHHA.ORG). CONSUMER EDUCATION IS IMPORTANT SINCE THE CHEMICALS AND SUBSTANCES ON THE LIST ARE FOUND IN OUR DAILY LIVES. MOST CONSUMERS ARE AWARE THAT PRODUCTS PRESENT SAFETY AND HEALTH RISKS, WHEN IMPROPERLY USED, HANDLED AND MAINTAINED.

### WARNING

THE MANUFACTURER'S WARRANTY DOES NOT COVER ANY DAMAGE OR DEFECT TO THE AIR CONDITIONER CAUSED BY THE ATTACHMENT OR USE OF ANY COMPONENTS, ACCESSORIES OR DEVICES (OTHER THAN THOSE AUTHORIZED BY THE MANUFACTURER) INTO, ONTO OR IN CONJUNCTION WITH THE AIR CONDITIONER. YOU SHOULD BE AWARE THAT THE USE OF UNAUTHORIZED COMPONENTS, ACCESSORIES OR DEVICES MAY ADVERSELY AFFECT THE OPERATION OF THE AIR CONDITIONER AND MAY ALSO ENDANGER LIFE AND PROPERTY. THE MANUFACTURER DISCLAIMS ANY RESPONSIBILITY FOR SUCH LOSS OR INJURY RESULTING FROM THE USE OF SUCH UNAUTHORIZED COMPONENTS, ACCESSORIES OR DEVICES.

### WARNING

DISCONNECT ALL POWER TO THE UNIT BEFORE STARTING MAINTENANCE. FAILURE TO DO SO CAN RESULT IN SEVERE ELECTRICAL SHOCK OR DEATH.

** WARNING**

DO NOT, UNDER ANY CIRCUMSTANCES, CONNECT RETURN DUCTWORK TO ANY OTHER HEAT PRODUCING DEVICE SUCH AS A FIREPLACE INSERT, STOVE, ETC. UNAUTHORIZED USE OF SUCH DEVICES MAY RESULT IN FIRE, CARBON MONOXIDE POISONING, EXPLOSION, PROPERTY DAMAGE, SEVERE PERSONAL INJURY OR DEATH.

** WARNING**

THE UNIT MUST BE PERMANENTLY GROUNDED. A GROUNDING LUG IS PROVIDED IN THE ELECTRIC HEAT KIT FOR A GROUND WIRE. (SEE FIGURES 16 AND 17.) FAILURE TO GROUND THIS UNIT CAN RESULT IN FIRE OR ELECTRICAL SHOCK CAUSING PROPERTY DAMAGE, SEVERE PERSONAL INJURY OR DEATH.

** WARNING**


ONLY ELECTRIC HEATER KITS SUPPLIED BY THIS MANUFACTURER AS DESCRIBED IN THIS PUBLICATION HAVE BEEN DESIGNED, TESTED, AND EVALUATED BY A NATIONALLY RECOGNIZED SAFETY TESTING AGENCY FOR USE WITH THIS UNIT. USE OF ANY OTHER MANUFACTURED ELECTRIC HEATERS INSTALLED WITHIN THIS UNIT MAY CAUSE HAZARDOUS CONDITIONS RESULTING IN PROPERTY DAMAGE, FIRE, BODILY INJURY OR DEATH.

** WARNING**

PROPOSITION 65: THIS APPLIANCE CONTAINS FIBERGLASS INSULATION. RESPIRABLE PARTICLES OF FIBERGLASS ARE KNOWN TO THE STATE OF CALIFORNIA TO CAUSE CANCER.

** CAUTION**

R-410A systems operate at higher pressures than R-22 systems. Do not use R-22 service equipment or components on R-410A equipment.

 Recognize this symbol as an indication of Important Safety Information!

## WARNING

**IMPORTANT: ALL MANUFACTURER PRODUCTS MEET CURRENT FEDERAL OSHA GUIDELINES FOR SAFETY. CALIFORNIA PROPOSITION 65 WARNINGS ARE REQUIRED FOR CERTAIN PRODUCTS, WHICH ARE NOT COVERED BY THE OSHA STANDARDS.**

**CALIFORNIA'S PROPOSITION 65 REQUIRES WARNINGS FOR PRODUCTS SOLD IN CALIFORNIA THAT CONTAIN, OR PRODUCE, ANY OF OVER 600 LISTED CHEMICALS KNOWN TO THE STATE OF CALIFORNIA TO CAUSE CANCER OR BIRTH DEFECTS SUCH AS FIBERGLASS INSULATION, LEAD IN BRASS, AND COMBUSTION PRODUCTS FROM NATURAL GAS.**

**ALL "NEW EQUIPMENT" SHIPPED FOR SALE IN CALIFORNIA WILL HAVE LABELS STATING THAT THE PRODUCT CONTAINS AND/OR PRODUCES PROPOSITION 65 CHEMICALS. ALTHOUGH WE HAVE NOT CHANGED OUR PROCESSES, HAVING THE SAME LABEL ON ALL OUR PRODUCTS FACILITATES MANUFACTURING AND SHIPPING. WE CANNOT ALWAYS KNOW "WHEN, OR IF" PRODUCTS WILL BE SOLD IN THE CALIFORNIA MARKET.**

**YOU MAY RECEIVE INQUIRIES FROM CUSTOMERS ABOUT CHEMICALS FOUND IN, OR PRODUCED BY, SOME OF OUR HEATING AND AIR-CONDITIONING EQUIPMENT, OR FOUND IN NATURAL GAS USED WITH SOME OF OUR PRODUCTS. LISTED BELOW ARE THOSE CHEMICALS AND SUBSTANCES COMMONLY ASSOCIATED WITH SIMILAR EQUIPMENT IN OUR INDUSTRY AND OTHER MANUFACTURERS.**

- GLASS WOOL (FIBERGLASS) INSULATION
- CARBON MONOXIDE (CO)
- FORMALDEHYDE
- BENZENE

**MORE DETAILS ARE AVAILABLE AT THE WEBSITES FOR OSHA (OCCUPATIONAL SAFETY AND HEALTH ADMINISTRATION), AT [WWW.OSHA.GOV](http://WWW.OSHA.GOV) AND THE STATE OF CALIFORNIA'S OEHHA (OFFICE OF ENVIRONMENTAL HEALTH HAZARD ASSESSMENT), AT [WWW.OEHHA.ORG](http://WWW.OEHHA.ORG). CONSUMER EDUCATION IS IMPORTANT SINCE THE CHEMICALS AND SUBSTANCES ON THE LIST ARE FOUND IN OUR DAILY LIVES. MOST CONSUMERS ARE AWARE THAT PRODUCTS PRESENT SAFETY AND HEALTH RISKS, WHEN IMPROPERLY USED, HANDLED AND MAINTAINED.**

## III. INTRODUCTION

This booklet contains the installation and operating instructions for your package heat pump. There are a few precautions that should be taken to derive maximum satisfaction from it. Improper installation can result in unsatisfactory operation or dangerous conditions.

Read this booklet and any instructions packaged with separate equipment required to make up the system prior to installation. Give this booklet to the owner and explain its provisions. The owner should retain this booklet for future reference.

**NOTE:** A load calculation must be performed to properly determine the required heating and cooling for the structure. Also, the duct must be properly designed and installed for proper airflow. Existing ductwork must be inspected for proper size and sealed system. Proper airflow is necessary for both user comfort and equipment performance.

**IMPORTANT:** Proper application, installation and maintenance of this equipment is a must if consumers are to receive the full benefit for which they have paid.

### A. R-410A REFRIGERANT

All units are factory charged with R-410A refrigerant.

#### 1. Specification of R-410A:

**Application:** **R-410A is not a drop-in replacement for R-22;** equipment designs must accommodate its higher pressures. It cannot be retrofitted into R-22 units.

**Pressure:** **The pressure of R-410A is approximately 60% (1.6 times) greater than R-22.** Recovery and recycle equipment, pumps, hoses and the like need to have design pressure ratings appropriate for R-410A. *Manifold sets need to range up to 800 psig high-side and 250 psig low-side with a 550 psig low-side retard. Hoses need to have a service pressure rating of 800 psig. Recovery cylinders need to have a 400 psig service pressure rating.* DOT 4BA400 or DOT BW400.

**Combustibility:** At pressures above 1 atmosphere, mixture of R-410A and air can become combustible. **R-410A and air should never be mixed in tanks or supply lines, or be allowed to accumulate in storage tanks. Leak checking should never be done with a mixture of R-410A and air.** Leak checking can be performed safely with nitrogen or a mixture of R-410A and nitrogen.

#### 2. Quick Reference Guide For R-410A

- R-410A refrigerant operates at approximately 60% higher pressure (1.6 times) than R-22. Ensure that servicing equipment is designed to operate with R-410A.
- R-410A refrigerant cylinders are pink.
- R-410A, as with other HFC's is only compatible with POE oils.
- Vacuum pumps will not remove moisture from POE oil.
- R-410A systems are to be charged with liquid refrigerants. Prior to March 1999, R-410A refrigerant cylinders had a dip tube. These cylinders should be kept upright for equipment charging. Post March 1999 cylinders do not have a dip tube and should be inverted to ensure liquid charging of the equipment.
- Do not install a suction line filter drier in the liquid line.
- A liquid line filter drier is standard on every unit.
- Desiccant (drying agent) must be compatible for POE oils and R-410A.

#### 3. Evaporator Coil / TXV

The thermostatic expansion valve is specifically designed to operate with R-410A. **DO NOT use an R-22 TXV. The existing evaporator must be replaced with the factory specified TXV evaporator specifically designed for R-410A.**

#### 4. Tools Required For Installing & Servicing R-410A Models

Manifold Sets:

- Up to 800 PSIG High side
- Up to 250 PSIG Low Side
- 550 PSIG Low Side Retard

Manifold Hoses:

- Service Pressure Rating of 800 PSIG

Recovery Cylinders:

-400 PSIG Pressure Rating

-Dept. of Transportation 4BA400 or BW400

### CAUTION

R-410A systems operate at higher pressures than R-22 systems. Do not use R-22 service equipment or components on R-410A equipment.

## IV. CHECKING PRODUCT RECEIVED

Upon receiving the unit, inspect it for any damage from shipment. Claims for damage, either shipping or concealed, should be filed immediately with the shipping company. Check the unit model number, heating size, electrical characteristics, and accessories to determine if they are correct.

## V. EQUIPMENT PROTECTION FROM THE ENVIRONMENT

The metal parts of this unit may be subject to rust or deterioration in adverse environmental conditions. This oxidation could shorten the equipment's useful life. Salt spray, fog or mist in seacoast areas, sulphur or chlorine from lawn watering systems, and various chemical contaminants from industries such as paper mills and petroleum refineries are especially corrosive.

**If the unit is to be installed in an area where contaminants are likely to be a problem, special attention should be given to the equipment location and exposure.**

1. Avoid having lawn sprinkler heads spray direction on the unit cabinet.
2. In coastal areas, locate the unit on the side of the building away from the waterfront.
3. Shielding provided by a fence or shrubs may give some protection.

**Regular maintenance will reduce the buildup of contaminants and help to protect the unit's finish.**

### WARNING

**DISCONNECT ALL POWER TO THE UNIT BEFORE STARTING MAINTENANCE. FAILURE TO DO SO CAN RESULT IN SEVERE ELECTRICAL SHOCK OR DEATH.**

1. Frequent washing of the cabinet, fan blade and coil with fresh water will remove most of the salt or other contaminants that build up on the unit.
2. Regular cleaning and waxing of the cabinet with a good automobile polish will provide some protection.
3. A good liquid cleaner may be used several times a year to remove matter that will not wash off with water.

Several different types of protective coatings are offered in some areas. These coatings may provide some benefit, but the effectiveness of such coating materials cannot be verified by the equipment manufacturer.

**The best protection is frequent cleaning, maintenance and minimal exposure to contaminants.**

## VI. INSTALLATION

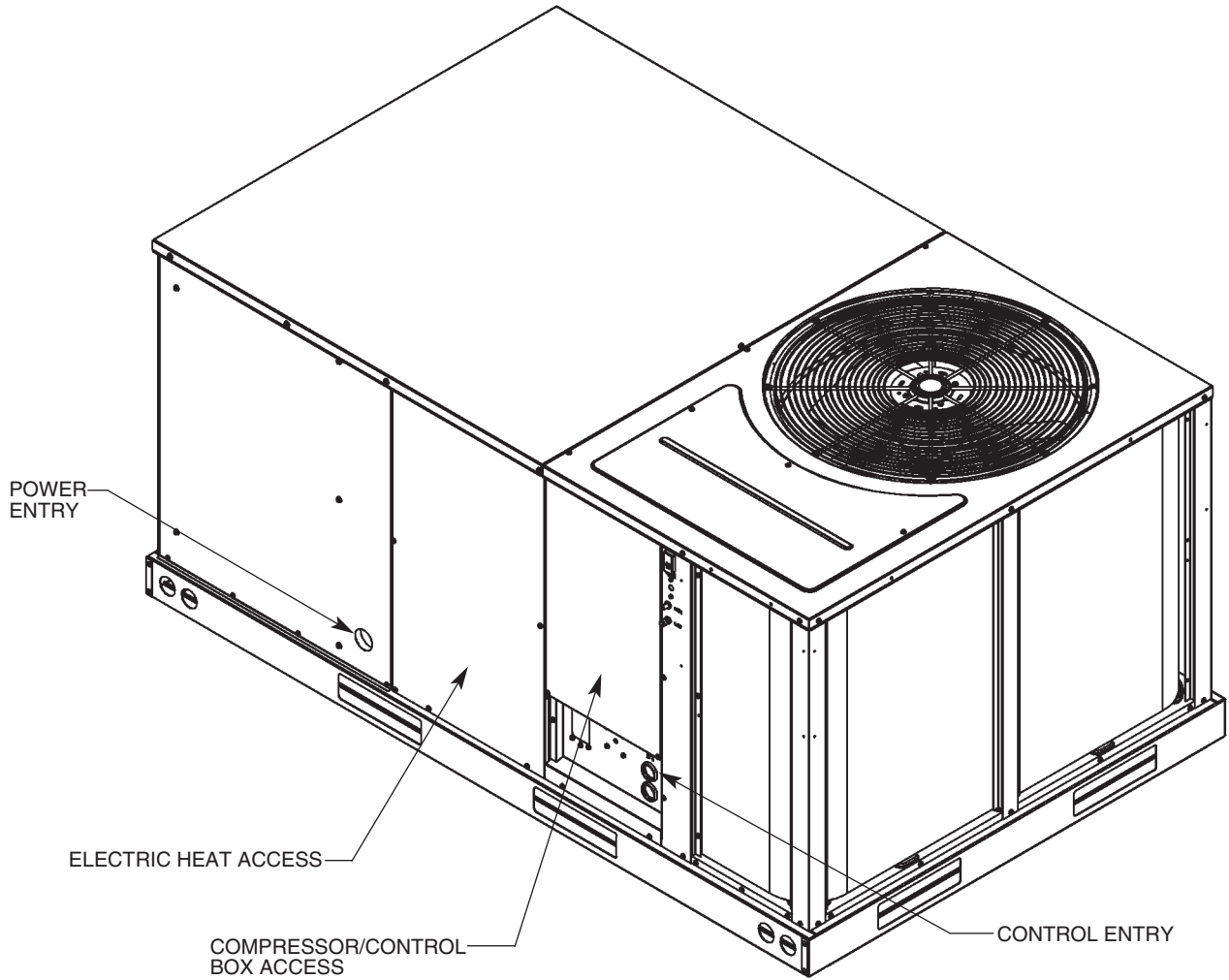
### A. GENERAL

#### 1. PRE-INSTALLATION CHECK-POINTS

Before attempting any installation, the following points should be carefully considered:

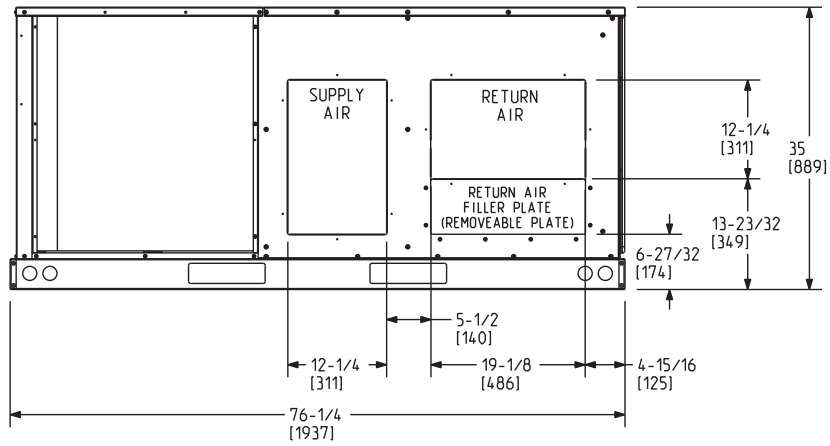
- a. Structural strength of supporting members.  
(rooftop installation)
- b. Clearances and provision for servicing.
- c. Power supply and wiring.
- d. Air duct connections.

**FIGURE 1**  
RJNL-C/RJPL-C 3-5 TON

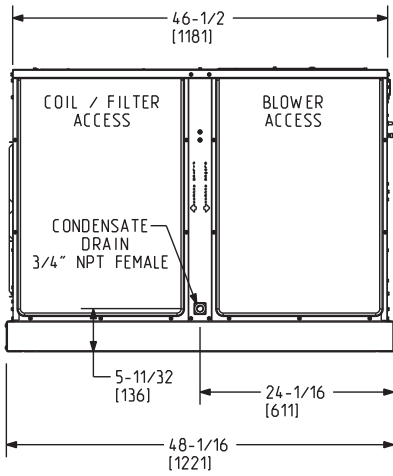


**FIGURE 2**  
**UNIT DIMENSIONS – 3-5 TONS**

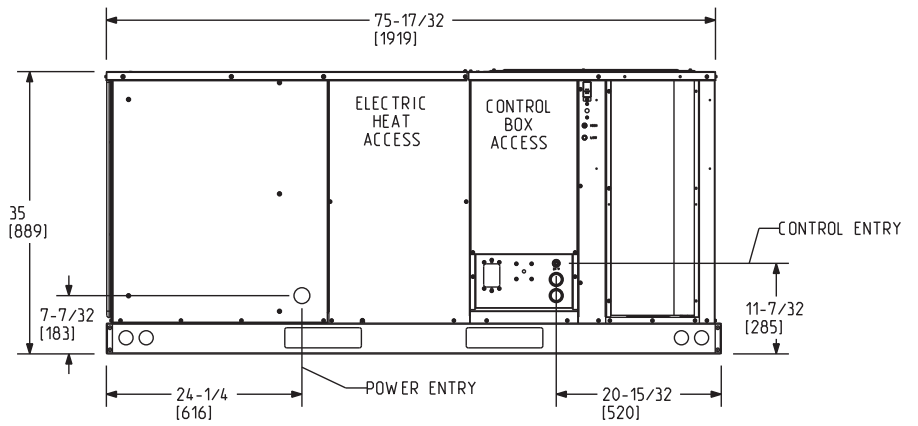
**BACK VIEW**



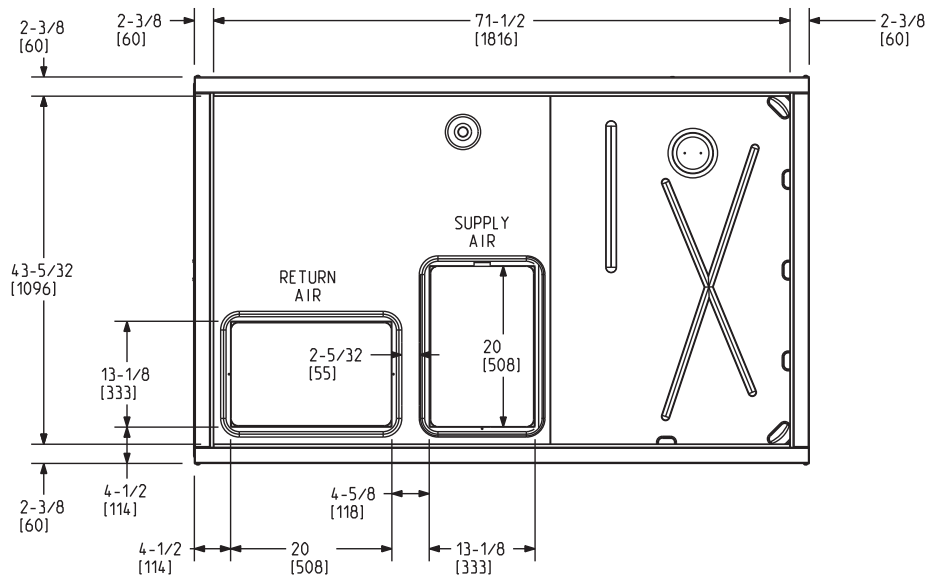
**SIDE VIEW**



**FRONT VIEW**



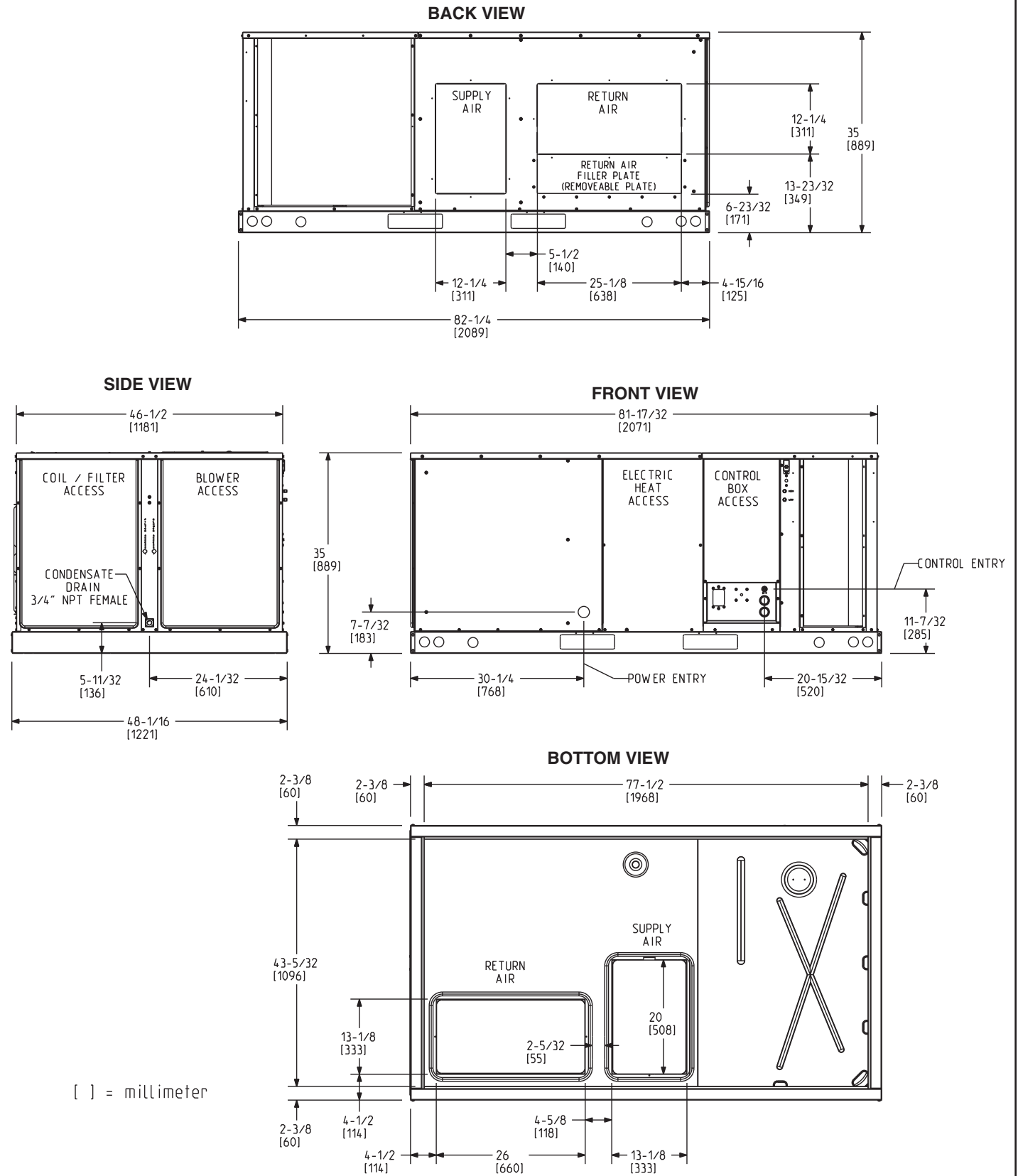
**BOTTOM VIEW**



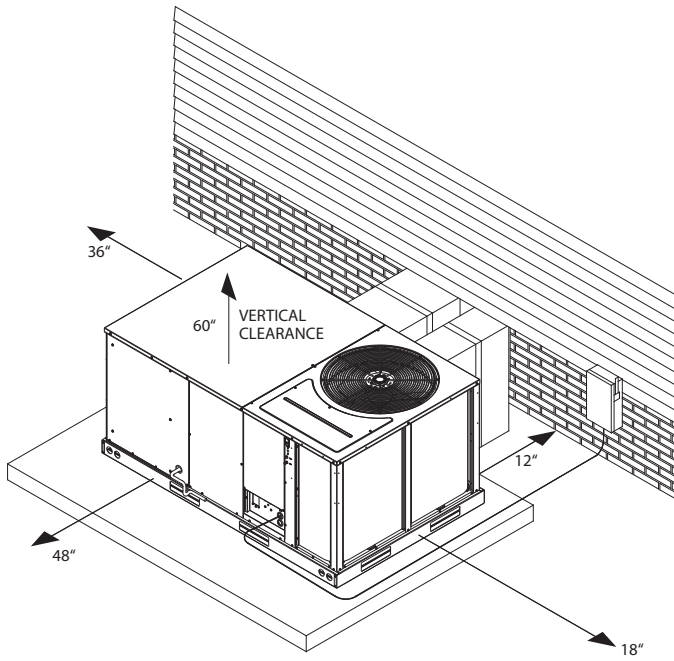
[ ] = millimeter



**FIGURE 3**  
**UNIT DIMENSIONS – 6 TON**

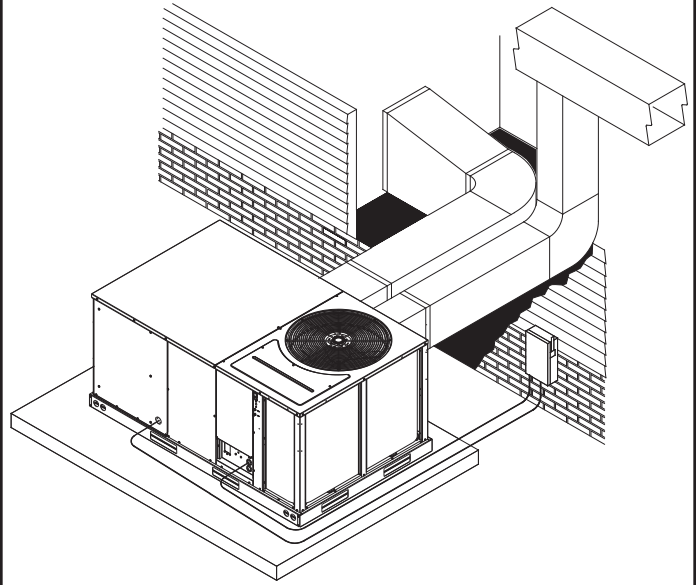


**FIGURE 4**  
**PACKAGED HEAT PUMP**  
**OUTSIDE SLAB INSTALLATION, BASEMENT OR**  
**CRAWL SPACE DISTRIBUTION SYSTEM**



\*Allow 57" for economizer on duct side.

**FIGURE 5**  
**PACKAGED HEAT PUMP**  
**OUTSIDE SLAB INSTALLATION, CLOSET DISTRIBUTION**  
**SYSTEM. SLAB FLOOR CONSTRUCTION**

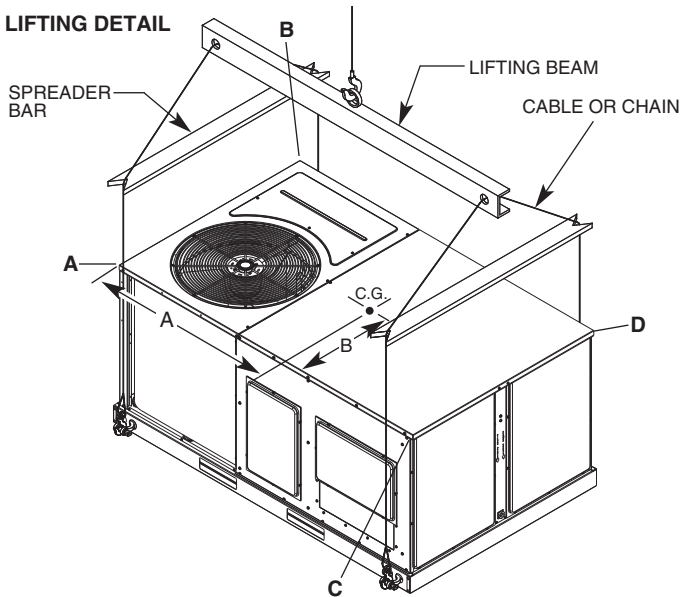


**FIGURE 6**  
**PACKAGED HEAT PUMP**  
**RIGGING FOR LIFTING**

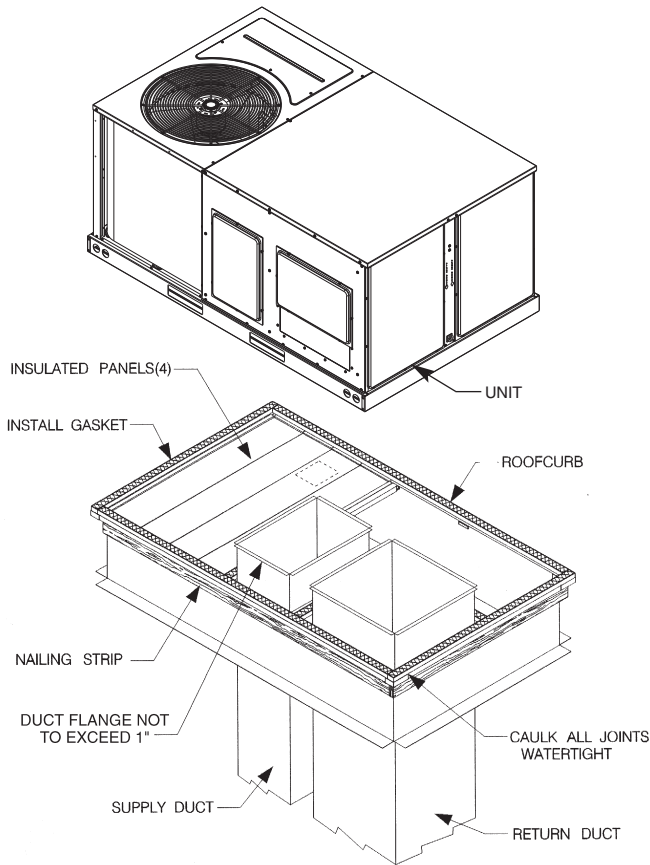
Capacity Tons [kW]	A in. [mm]	B in. [mm]
3.5 [10.6-17.6]	38 1/4 [972]	25 3/4 [654]
6 [21.1]	39 [991]	26 1/8 [664]

Capacity Tons [kW]	Corner Weights by Percentage			
	A	B	C	D
3.5 [10.6-17.6]	22%	27%	23%	28%
6 [21.1]	23%	29%	21%	27%

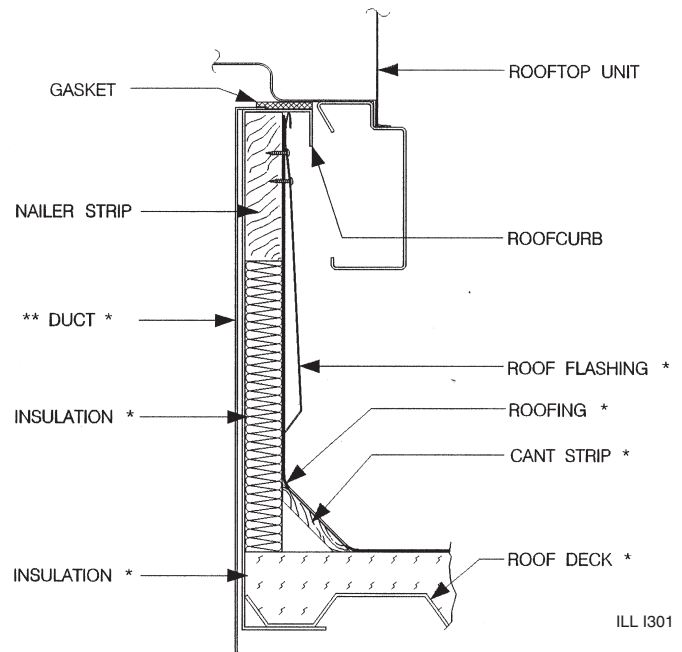
**LIFTING DETAIL**



**FIGURE 7  
PACKAGED HEAT PUMP  
ROOFCURB INSTALLATION**



ILL 1300



ILL 1301

\* BY CONTRACTOR

\*\* FOR INSTALLATION OF DUCT AS SHOWN, USE RECOMMENDED DUCT SIZES FROM ROOFCURB INSTALLATION INSTRUCTIONS. FOR DUCT FLANGE ATTACHMENT TO UNIT, SEE UNIT INSTALLATION INSTRUCTIONS FOR RECOMMENDED DUCT SIZES.

- e. Drain facilities and connections.
- f. Location for minimum noise.

## 2. LOCATION

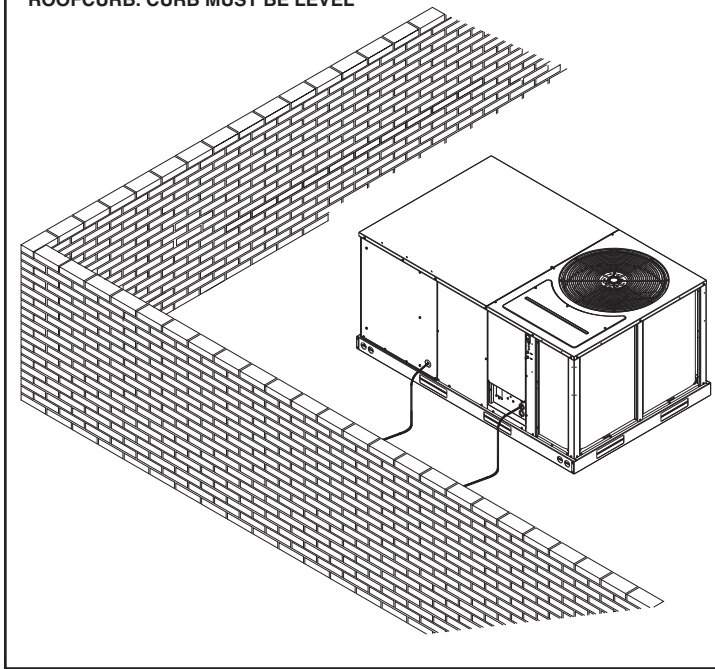
These units are designed for outdoor installations. They can be mounted on a slab or rooftop. They are not to be installed within any part of a structure such as an attic, crawl space, closet, or any other place where condenser air flow is restricted or other than outdoor ambient conditions prevail. Since the application of the units is of the outdoor type, it is important to consult your local code authorities at the time the first installation is made.

## B. OUTSIDE SLAB INSTALLATION

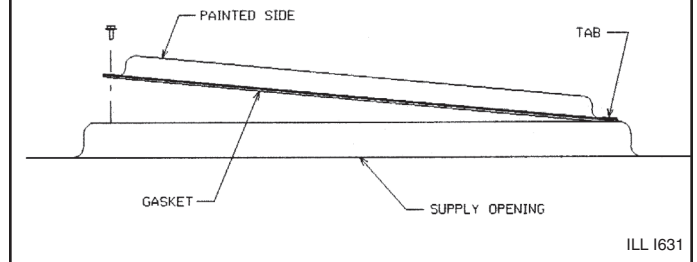
(Typical outdoor slab installations are shown in Figures 4 and 5.)

1. Select a location where external water drainage cannot collect around the unit.
2. Provide a level concrete slab extending 3" beyond all four sides of the unit. The slab should be sufficient above grade to prevent ground water from entering the unit. **IMPORTANT:** To prevent transmission of noise or vibration, slab should not be connected to building structure.
3. The location of the unit should be such as to provide proper access for inspection and servicing.
4. Locate unit where operating sounds will not disturb owner or neighbors.
5. Locate unit so roof runoff water does not pour directly on the unit. Provide gutter or other shielding at roof level. Do not locate unit in an area where excessive snow drifting may occur or accumulate.
6. It is essential that the unit be elevated above the base pad to allow for condensate drainage and possible refreezing of condensation. Provide a base pad which is slightly pitched away from the structure. Route condensate off base pad to an area which will not become slippery and result in personal injury.
7. Where snowfall is anticipated, the height of the unit above the ground level must be considered. Mount unit high enough to be above average area snowfall and to allow for proper condensate drainage.

**FIGURE 8**  
**PACKAGED HEAT PUMP**  
**FLAT ROOFTOP INSTALLATION, ATTIC OR DROP CEILING**  
**DISTRIBUTION SYSTEM. MOUNTED ON**  
**ROOFCURB. CURB MUST BE LEVEL**



**FIGURE 9**  
**COVER GASKET DETAIL**



ILL 1631

### C. CLEARANCES

The following minimum clearances must be observed for proper unit performance and serviceability.

1. Provide 48" minimum clearance at the front of the unit. Provide 36" minimum clearance at the left and right side of the unit for service access.
2. Provide 60" minimum clearance between top of unit and maximum 3 foot overhang.
3. Unit is design certified for application on combustible flooring with 0" minimum clearance.
4. See Figure 4 for illustration of minimum installation-service clearances.

### D. ROOFTOP INSTALLATION

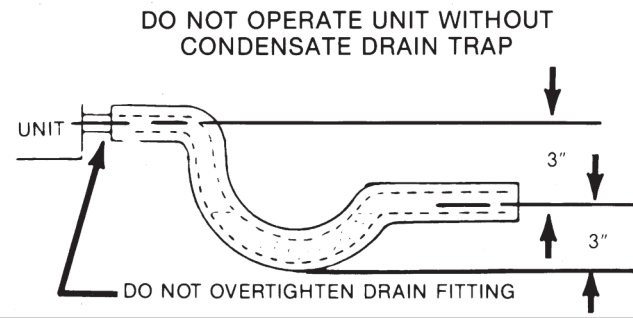
1. Before locating the unit on the roof, make sure that the strength of the roof and beams is adequate at that point to support the weight involved. (See specification sheet for weight of unit.) This is very important and user's responsibility.
2. For rigging and roofcurb details, see Figures 6 and 7. Use field-furnished spreaders.
3. For roofcurb assembly, see Roofcurb Installation Instructions.
4. If the roofcurb is not used, provisions for disposing of condensate water runoff during defrosting must be provided.
5. The unit should be placed on a solid and level roofcurb or platform of adequate strength. See Figure 8.
6. The location of the unit on the roof should be such as to provide proper access for inspection and servicing.

**IMPORTANT:** *If unit will not be put into service immediately, cover supply and return openings to prevent excessive condensation.*

## VII. DUCTWORK

Ductwork should be fabricated by the installing contractor in accordance with local codes and NFPA90A. Industry manuals may be used as a guide when sizing and designing the duct system - contact Air Conditioning Contractors of America, 1513 16th St. N.W., Washington, D.C. 20036.

**FIGURE 10**  
CONDENSATE DRAIN



## **⚠ WARNING**

**DO NOT, UNDER ANY CIRCUMSTANCES, CONNECT RETURN DUCTWORK TO ANY OTHER HEAT PRODUCING DEVICE SUCH AS A FIREPLACE INSERT, STOVE, ETC. UNAUTHORIZED USE OF SUCH DEVICES MAY RESULT IN FIRE, CARBON MONOXIDE POISONING, EXPLOSION, PROPERTY DAMAGE, SEVERE PERSONAL INJURY OR DEATH.**

The unit should be placed as close to the space to be air conditioned as possible allowing clearance dimensions as indicated. Ducts should be run as directly as possible to supply and return outlets. Use of non-flammable waterproof flexible connectors on both supply and return connections at the unit to reduce noise transmission is recommended.

It is preferable to install the unit on the roof of the structure if the registers or diffusers are located on the wall or in the ceiling. A slab installation could be considered when the registers are low on a wall or in the floor.

On ductwork exposed to outside air conditions of temperature and humidity, use a minimum of 2" of insulation and a vapor barrier. Distribution system in attic, furred space or crawl space should be insulated with at least 2" of insulation with vapor barrier. One-half to 1" thickness of insulation is usually sufficient for ductwork inside the air conditioned space.

Balancing dampers should be provided for each branch duct in the supply system. Ductwork should be properly supported from the structure.

When installing ductwork, consider the following items:

1. Noncombustible flexible connectors should be used between ductwork and unit to reduce noise and vibration transmission into the ductwork.
2. When auxiliary heaters are installed, use noncombustible flexible connectors and clearance to combustible material of 0" for the first 3 feet of discharge duct. Clearance to unit top and side is 0".

## **VIII. FILTERS**

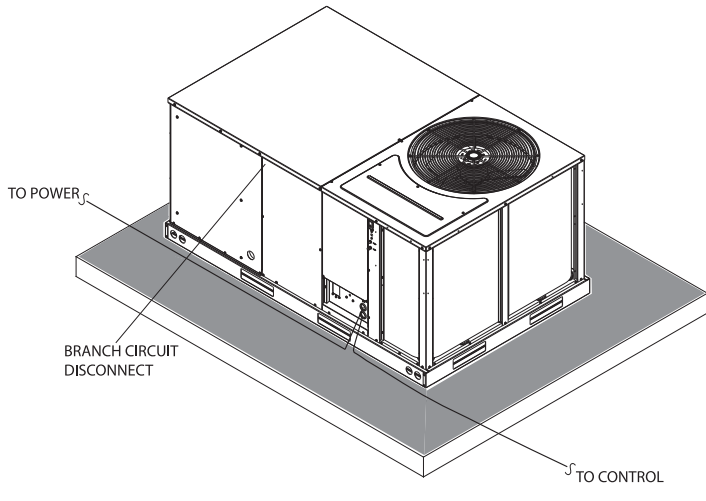
This unit is provided with 2 - 25" x 16" x 1" (3-5 ton) 4 - 16" x 16" x 1" (6 ton) disposable filters. When replacing filters, ensure they are inserted fully to the back to prevent bypass.

## **IX. CONVERSION PROCEDURE**

### **DOWNFLOW TO HORIZONTAL**

1. Remove the screws and covers from the outside of the supply and return sections.
2. Install the covers in the bottom supply and return openings with the painted side up. See Figure 9. Use the existing gasket to seal the covers.
3. Secure the supply cover to the base of the unit with 1 screw, engaging prepunched tab in unit base.
4. Secure the return cover to the base of the unit with screws, engaging prepunched holes in the unit base.

**FIGURE 11**  
**BRANCH CIRCUIT DISCONNECT LOCATION**



**TABLE A**  
**WIRE SIZES**

AWG Copper Wire Size	AWG Aluminum Wire Size	Connector Type and Size (or equivalent)	
#12	#10	T&B Wire Nut	PT2
#10	#8	T&B Wire Nut	PT3
#8	#6	IlSCO Split Bolt	AK-6
#6	#4	IlSCO Split Bolt	AK-4
#4	#2	IlSCO Split Bolt	AK-2
#3	#1	IlSCO Split Bolt	AK-1/0
#2	#0	IlSCO Split Bolt	AK-1/0
#1	#00	IlSCO Split Bolt	AK-2/0
#0	#000	IlSCO Split Bolt	AK-4/0

## X. CONDENSATE DRAIN

The condensate drain connection of the evaporator is 3/4" nominal female pipe thread. **IMPORTANT:** Install a condensate trap to ensure proper condensate drainage. See Figure 10.

## XI. CONDENSATE DRAIN, OUTDOOR COIL

The outdoor coil during heating operation will sweat or run water off. The outdoor coil will also run water off during the defrost cycle. See Section V, Installation, for mounting precautions.

## XII. ELECTRICAL WIRING

Field wiring must comply with the National Electrical Code\* and local ordinances that may apply.

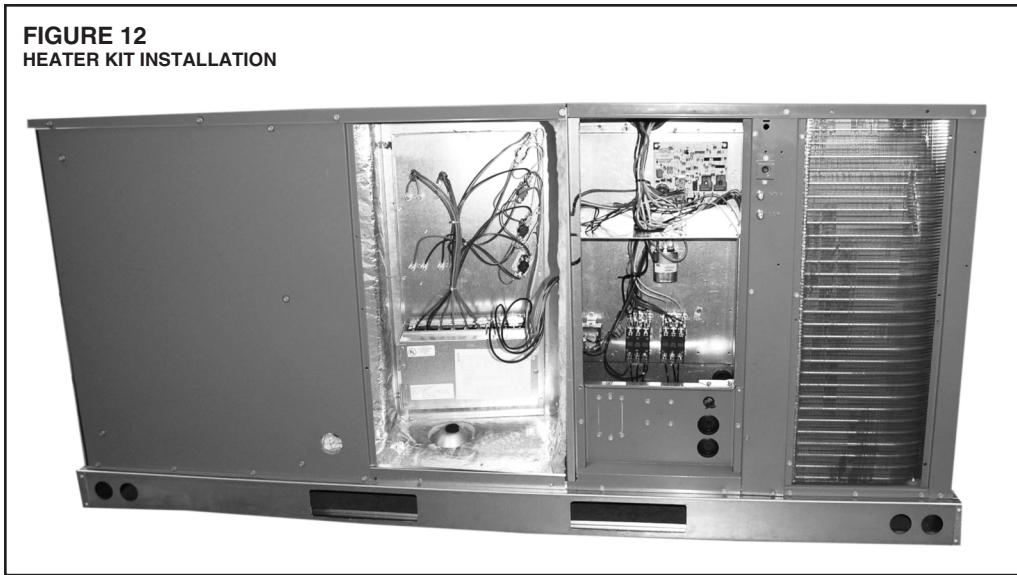
\*C.E.C. in Canada

### A. POWER WIRING

1. It is important that proper electrical power is available at the unit. Voltage should not vary more than 10% from that stamped on the unit rating plate. On three phase units, phases must be balanced within 3%.
- 2. Install a branch circuit disconnect within sight of the unit and of adequate size to handle the starting current. Refer to Figure 11 for proper location.
3. For branch circuit wiring (main power supply to unit disconnect), the minimum wire size can be determined from Table C using the circuit ampacity found on the unit nameplate or from the Electrical Data.
4. This unit incorporates single point electrical connection for unit and electric heat accessory.
5. Power wiring must be run in grounded rain-tight conduit. Connect the power field wiring as follows:
  - a. NO ELECTRIC HEAT - Connect the field wires directly to the contactor pigtailed in the electric heat access area. Connect ground wire to ground lug.
  - b. WITH ELECTRIC HEAT - Connect the field wires to the terminal block on the electric heater kit in the electric heat access area. Connect the ground wire to the ground lug on the heater kit.

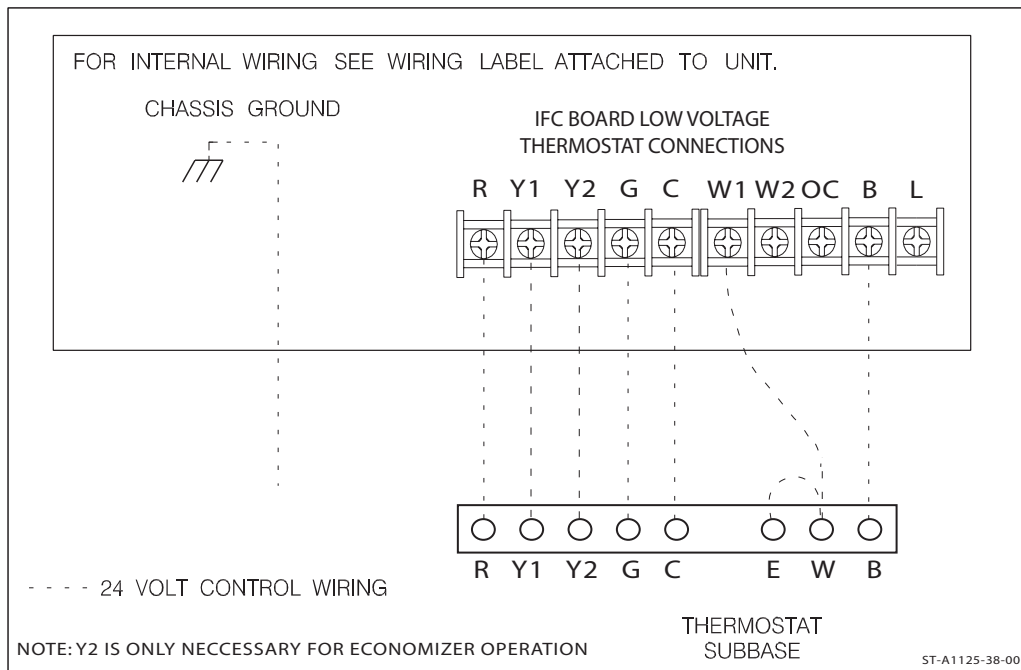
**NOTE:** For field installation of a heater kit, follow the instructions provided with the heater kit.

**FIGURE 12**  
HEATER KIT INSTALLATION



**FIGURE 13**  
VOLTAGE CONNECTIONS DIAGRAM

STANDARD WIRING



6. The pigtail wires in the electric heat access area are factory wired to the contactor in the control box.
7. DO NOT connect aluminum field wires to electric heat kit power input terminals.

**B. SPECIAL INSTRUCTIONS FOR POWER WIRING WITH ALUMINUM CONDUCTORS.**

1. Select the equivalent aluminum wire size from the tabulation below:
2. Attach a length (6" or more) of recommended size copper wire to the unit terminals L1 and L3 for single phase, L1, L2, L3 for three phase.
3. Splice copper wire pigtails to aluminum wire with U.L. recognized connectors for copper-aluminum splices. Follow these instructions very carefully to make a positive and lasting connection;
  - a. Strip insulation from aluminum conductor.
  - b. Coat the stripped end of the aluminum wire with the recommended inhibitor and wire brush aluminum surface through inhibitor. Inhibitors: Brundy, Pentex "A"; Alcoa, No. 2EJC; T&B KPOR Shield.

**TABLE C**  
**COPPER WIRE SIZE – AWG (1% VOLTAGE DROP)**

	300	4	3	2	2	1	1/0	1/0	2/0	2/0	3/0	3/0	3/0	4/0	4/0	4/0	4/0	250	250	250	250	300	300	300	300	300	350	350	350	350
Supply	250	4	4	3	3	2	1	1	1/0	1/0	2/0	2/0	2/0	3/0	3/0	3/0	4/0	4/0	4/0	4/0	4/0	250	250	250	250	250	350	350	350	350
Wire	200	6	4	4	4	3	2	2	1	1	1/0	1/0	1/0	2/0	2/0	2/0	3/0	3/0	3/0	3/0	3/0	4/0	4/0	4/0	4/0	4/0	300	300	300	300
Length	150	8	6	6	4	4	4	3	3	2	2	1	1	1/0	1/0	1/0	1/0	2/0	2/0	2/0	2/0	2/0	3/0	3/0	3/0	3/0	4/0	4/0	4/0	4/0
Feet	100	10	8	8	6	6	6	4	4	4	3	3	2	2	1	1	1	1	1	1	1/0	1/0	1/0	1/0	1/0	1/0	1/0	2/0	2/0	2/0
	50	14	12	10	10	8	8	6	6	6	4	4	4	3	3	3	2	2	2	2	2	1	1	1	1	1/0	1/0	1/0	2/0	2/0
		15	20	25	30	35	40	45	50	55	60	65	70	75	80	85	90	95	100	105	110	115	120	125	130	135	140	145	150	155

Circuit Ampacity

**NOTE:**

1. Wire size based on 60°C type copper conductors below 100 ampacity.
2. Wire size based on 75°C type copper conductors for 100 ampacity and above.

- c. Clean and recoat aluminum conductor with inhibitor.
- d. Make the splice using the above listed wire nuts or split bolt connectors.
- e. Coat the entire connection with inhibitor and wrap with electrical insulating tape.

WARRANTY MAY NOT APPLY IF CONNECTIONS ARE NOT MADE PER INSTRUCTIONS

**C. CONTROL WIRING (Class II)**

1. Low voltage wiring should not be run in conduit with power wiring.
2. Control wiring is routed through the 7/8" hole adjacent to the compressor access panel. Use a minimum #18 AWG thermostat wire. For wire lengths exceeding 50', use #16 AWG thermostat wire. The low voltage wires are connected to the unit pig-tails which are supplied with the unit below the unit control box.
3. It is necessary that only heat pump thermostats be used.
4. Figure 13 shows representative low voltage connection diagrams. Read your thermostat installation instructions for any special requirements for your specific thermostat.

NOTE — Units installed in Canada require that an outdoor thermostat (30,000 min. cycles of endurance) be installed and be wired with C.E.C. Class I wiring.

**D. INTERNAL WIRING**

1. A diagram of the internal wiring of this unit is located on the inside of the compressor access panel. If any of the original wire as supplied with the appliance must be replaced, the wire gauge and insulation must be the same as original wiring.

**IMPORTANT:** Some single phase units are equipped with a single pole contactor. Caution must be exercised when servicing as only one leg of the power supply is broken with the contactor. Some models are equipped with electrically commutated blower motors which are constantly energized unless the main unit disconnect is in the off position.

**E. GROUNDING**

**⚠ WARNING**

**THE UNIT MUST BE PERMANENTLY GROUNDED. A GROUNDING LUG IS PROVIDED IN THE ELECTRIC HEAT ACCESS AREA FOR A GROUND WIRE. FAILURE TO GROUND THIS UNIT CAN RESULT IN FIRE OR ELECTRICAL SHOCK CAUSING PROPERTY DAMAGE, SEVERE PERSONAL INJURY OR DEATH.**

**F. THERMOSTAT**

The thermostat should be mounted on an inside wall about five feet above the floor in a location where it will not be affected by unconditioned air, sun, or drafts from open doors or other sources. READ installation instructions in heat pump thermostat package CAREFULLY because each has some different wiring requirements.

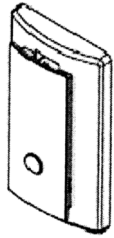
**XIII. INDOOR AIR FLOW DATA**

Direct-drive blower models are shipped factory wired for the proper speed at a typical external static. Belt-drive blower models have motor sheaves set for proper CFM at a typical external static.



## XIV. ROOM TEMPERATURE SENSORS

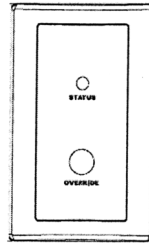
**FIGURE 14**  
FLUSH MOUNT ROOM TEMPERATURE SENSOR FOR NETWORKED DDC APPLICATIONS  
(REPLACES THERMOSTAT)



**ROOM TEMPERATURE SENSOR WITH TIMED OVERRIDE BUTTON**

ZNS1

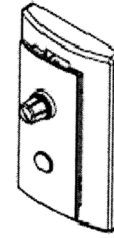
←10kΩ room temperature sensor transmits room temperature to DDC system. Times override buttons allows tenant to change from unoccupied temperature setpoint to occupied temperature setpoint for a preset time.



**ROOM TEMPERATURE SENSOR WITH TIMED OVERRIDE BUTTON AND STATUS INDICATOR**

ZNS2

←10kΩ room temperature sensor transmits room temperature to DDC system. Times override button allows tenant to change from unoccupied temperature setpoint to occupied temperature setpoint for a preset time. Status Indicator Light transmits ALARM flash code to occupied space.



**ROOM TEMPERATURE SENSOR WITH SETPOINT ADJUSTMENT AND TIMED OVERRIDE BUTTON**

ZNS3

←10kΩ room temperature sensor with setpoint adjustment transmits room temperature to DDC system along with desired occupied room temperature setpoint. Timed override button allows tenant to change from unoccupied temperature setpoint to occupied temperature setpoint for a preset time.

## XV. CRANKCASE HEAT (OPTIONAL)

Crankcase heat is not required on scroll type compressors, but may be necessary for difficult starting situations.

## XVI. PRE-START CHECK

1. Is unit properly located and slightly slanted toward indoor condensate drain?
2. Is ductwork insulated, weatherproofed, with proper spacing to combustible materials?
3. Is air free to travel to and from outdoor coil? (See Figure 4.)
4. Is the wiring correct, tight, and according to unit wiring diagram?
5. Is unit grounded?
6. Are field supplied air filters in place and clean?
7. Do the outdoor fan and indoor blower turn freely without rubbing, and are they tight on the motor shafts?
8. Is unit elevated to allow for outdoor coil condensate drainage during heating operation and defrost?

## XVII. STARTUP

1. Turn thermostat to "OFF," turn "on" power supply at disconnect switch.
2. Turn temperature setting as high as it will go.
3. Turn fan switch to "ON."
4. Indoor blower should run. Be sure it is running in the right direction.
5. Turn fan switch to "AUTO." Turn system switch to "COOL" and turn temperature setting below room temperature. Unit should run in cooling mode.
6. Is outdoor fan operating correctly in the right direction?
7. Is compressor running correctly.
8. Turn thermostat system switch to "HEAT." Unit should stop. Wait 5 minutes, then raise temperature setting to above room temperature. Unit should run in heating mode and after about 30 to 50 seconds auxiliary heaters, if installed, should come on.
9. Check the refrigerant charge using the instructions located on compressor access panel cover. Replace service port caps. Service port cores are for system access only and will leak if not tightly capped.
10. Turn thermostat system switch to proper mode "HEAT" or "COOL" and set thermostat to proper temperature setting. Record the following after the unit has run some time.
  - A. Operating Mode \_\_\_\_\_
  - B. Discharge Pressure (High) \_\_\_\_\_ PSIG
  - C. Vapor Pressure at Compressor (Low) \_\_\_\_\_ PSIG

- D. Vapor Line Temperature at Compressor \_\_\_\_\_ °F.
- E. Indoor Dry Bulb \_\_\_\_\_ °F.
- F. Indoor Wet Bulb \_\_\_\_\_ °F.
- G. Outdoor Dry Bulb \_\_\_\_\_ °F.
- H. Outdoor Wet Bulb \_\_\_\_\_ °F.
- I. Voltage at Contactor \_\_\_\_\_ Volts
- J. Current at Contactor \_\_\_\_\_ Amps
- K. Model Number \_\_\_\_\_
- L. Serial Number \_\_\_\_\_
- M. Location \_\_\_\_\_
- N. Owner \_\_\_\_\_
- O. Date \_\_\_\_\_

11. Adjust discharge air grilles and balance system.
12. Check ducts for condensation and air leaks.
13. Check unit for tubing and sheet metal rattles.
14. Instruct the owner on operation and maintenance.
15. Leave "INSTALLATION" and "USE AND CARE" instructions with owner

## XVIII. OPERATION

Most single phase units are operated PSC (no start relay or start capacitor). It is important that such systems be off for a minimum of 5 minutes before restarting to allow equalization of pressures. The thermostat should not be moved to cycle unit without waiting five minutes. To do so may cause the compressor to stop on an automatic open overload device or blow a fuse. Poor electrical service can cause nuisance tripping in overloads or blow fuses.

**IMPORTANT:** *The compressor has an internal overload protector. Under some conditions, it can take up to 2 hours for this overload to reset. Make sure overload has had time to reset before condemning the compressor.*

Some units are equipped with a time delay control (TDC1). The control allows the blower to operate for up to 90 seconds after the thermostat is satisfied.

## XIX. AUXILIARY HEAT

The amount of auxiliary heat required depends on the heat loss of the structure to be heated and the capacity of the heat pump. It is good practice to install strip heat to maintain at least 60°F indoor temperatures in case of compressor failure. The auxiliary heat is energized by the second stage of the thermostat. The amount of electric heat that is allowed to come on, as determined by the output of the heat pump, may be controlled by an outdoor thermostat.

### WARNING

**ONLY ELECTRIC HEATER KITS SUPPLIED BY THIS MANUFACTURER AS DESCRIBED IN THIS PUBLICATION HAVE BEEN DESIGNED, TESTED, AND EVALUATED BY A NATIONALLY RECOGNIZED SAFETY TESTING AGENCY FOR USE WITH THIS UNIT. USE OF ANY OTHER MANUFACTURED ELECTRIC HEATERS INSTALLED WITHIN THIS UNIT MAY CAUSE HAZARDOUS CONDITIONS RESULTING IN PROPERTY DAMAGE, FIRE, BODILY INJURY OR DEATH.**

### A. CONTROL SYSTEM OPERATION

1. In the cooling mode, the thermostat will, on a call for cooling, energize the compressor contactor and the indoor blower relay. The indoor blower can be operated continuously by setting the thermostat fan switch at the "ON" position. The reversing valve coil is de-energized.
2. In the heating mode, the first heat stage of the thermostat will energize the compressor contactor and the indoor blower relay. The second heat stage will turn on one or more supplementary resistance heaters. The reversing valve is energized except in defrost. If required or considered desirable, the resistance heat may also be controlled by outdoor thermostats.

## XX. DEMAND DEFROST CONTROL AND HIGH/LOW PRESSURE CONTROLS

The demand defrost control monitors the outdoor ambient temperature, outdoor coil temperature and the compressor run time to determine when a defrost cycle is required.

**Enhanced Feature Demand Defrost Control:** This defrost control has high and low pressure control inputs with unique pressure switch logic built into the microprocessor to provide compressor and system protection without nuisance lockouts. The control cycles the compressor off for 30 seconds at the beginning and the end of the defrost cycle to eliminate the increased compressor noise caused by rapidly changing system pressures when the reversing valve switches. See next page for diagnostic flash codes and sensor resistance values at various temperatures.

## DEFROST INITIATION

A defrost will be initiated when the three conditions below are satisfied:

1. The outdoor coil temperature is below 35°F as measured by a good coil sensor,
2. The compressor has operated for at least 34 minutes with the outdoor coil temperature below 35°F and
3. The measured difference between the ambient temperature and the outdoor coil temperature is greater than the calculated difference determined by the defrost control microprocessor.

## DEFROST TERMINATION

Once a defrost is initiated, the defrost will continue until fourteen minutes has elapsed or the coil temperature has reached the selected termination temperature. The factory setting is 70°F but can be changed to 50°F, 60°F, or 80°F by relocating the jumper on the control board.

## TEMPERATURE SENSORS

The coil sensor is located on the outdoor coil near the point fed by the distribution tubes from the expansion device, on the top most cross-over tube. The ambient air sensor is located outside the control box so it can sense outdoor temperatures.

If the ambient sensor fails, the defrost control will initiate a defrost every 34 minutes of compressor run time with the coil temperature below 35°F.

If the coil sensor fails, the defrost control will not initiate a defrost.

## TEST MODE

The test mode is initiated by shorting the TEST pins. The unit must have an active heat pump heating call to enter the test mode. In this mode of operation, the enable temperature is ignored and all timers are sped up. To initiate a manual defrost, short and hold the TEST pins. Remove the short when the system switches to defrost mode after the compressor noise abatement delay. The defrost will terminate on time (14 minutes) or when the termination temperature has been reached.

Test Sequence of Operation:

- 1) Provide a heating call to the heat pump.
- 2) Short test pins to bypass anti-short cycle timer. (If unit is running, this step is not necessary.)
- 3) Short test pins and hold them shorted to enter defrost mode.
- 4) Release test pins once control exits noise abatement delay.
- 5) Monitor coil temperature when control exits defrost.
- 6) Unit should return to heating mode.

## TROUBLE SHOOTING DEMAND DEFROST

During the test mode the coil temperature should be monitored. If the system exits defrost at approximately the termination temperature, the control is operating normally. If not, check the coil and ambient temperature sensor resistances, using the sensor temperature vs. resistance table at the end of this section.

Immerse the sensor in water and measure the resistance of the sensor. At 35°F the resistance of the sensor should be approximately 30,000 ohms.

Ensure that the coil sensor is properly installed that is not loose or touching the cabinet.

## HIGH/LOW PRESSURE CONTROL MONITORING - ENHANCED DEFROST CONTROL

Status of high and low pressure controls is monitored by the enhanced feature demand defrost control and the following actions are taken.

**High Pressure Control** – Provides active protection in both cooling and heating modes at all outdoor ambient temperatures. The high pressure control is an automatic reset type and opens at approximately 610 psig and closes at approximately 420 psig. The compressor and fan motor will stop when the high pressure control opens and will start again if the high side pressure drops to approximately 420 psig where the automatic reset high pressure control resets. If the high pressure control opens 3 times within a

particular call for heating or cooling operation, the defrost control will lock out compressor and outdoor fan operation.

**Low Pressure Control** – Provides active protection in both heating and cooling modes at all outdoor ambient temperatures. The low pressure control is an automatic reset type and opens at approximately 15 psig and closes at approximately 40 psig. Operation is slightly different between cooling and heating modes.

**Cooling Mode:** The compressor and fan motor will stop when the low pressure control opens and will start again when the low side pressure rises to approximately 40 psig after the low pressure control automatically resets. If the low pressure switch opens 3 times within a particular call for cooling operation, the defrost control will lock out compressor and outdoor fan operation.

**Heating Mode:** The compressor and outdoor fan motor will stop when the low pressure control opens and will start again when the low side pressure rises to approximately 40 psig when the low pressure control automatically resets. If the low pressure switch trips 3 times within 120 minutes of operation during a particular call for heating operation, the defrost control will lock out compressor and outdoor fan operation. If the lock-out due to low pressure occurs at an outdoor ambient temperature below 5°F, the defrost control will automatically exit the lock-out mode when the outdoor ambient temperature rises to 5°F. This feature is necessary since the low pressure control could possibly have opened due to the outdoor ambient being very low rather than an actual system fault.

**Exiting Lock-Out Mode:** To exit the lock-out mode, remove 24 volts to the defrost control by removing power to the unit or by shorting the two defrost control pins together.

## ENHANCED FEATURE DEFROST CONTROL DIAGNOSTIC CODES

LED 1	LED 2	Control Board Status
OFF	OFF	No Power
ON	ON	Coil Sensor Failure
OFF	ON	Ambient Sensor Failure
FLASH	FLASH	Normal
OFF	FLASH	Low Pressure Lockout (short test pins to reset)
FLASH	OFF	High Pressure Lockout (short test pins to reset)
ON	FLASH	Low Pressure Control Open
FLASH	ON	High Pressure Control Open
Alternate Flashing		5 Minute Time Delay

## SENSOR TEMPERATURE VS. RESISTANCE TABLE

Degrees C	Degrees F	Ohms
-20	-4	96,974
-10	14	55,298
0	32	32,650
10	50	19,903
20	68	12,493
25	77	10,000
30	86	8,056
40	104	5,324

## XXI. REPLACEMENT PARTS

Contact your local distributor for a complete parts list.

## XXII. CHARGE INFORMATION

Refer to the appropriate charge chart included in this manual.

## XXIII. TROUBLESHOOTING

Refer to the troubleshooting chart included in this manual.

## XXIV. WIRING DIAGRAMS

Refer to the appropriate wiring diagram included in this manual.

# XXV. GENERAL DATA - RJNL-C MODELS

## NOMINAL SIZES 3-6 TONS [10.6-21.1 kW]

Model RJNL - Series	C036CL	C036CM	C036DL	C036DM
<b>Cooling performance<sup>1</sup></b>				<b>Continued -&gt;</b>
Gross Cooling Capacity Btu [kW]	37,800 [11.08]	37,800 [11.08]	37,800 [11.08]	37,800 [11.08]
EER, SEER <sup>2</sup>	11.5/13	11.5/13	11.5/13	11.5/13
Nominal CFM/AHRI Rated CFM [L/s]	1200/1200 [566/566]	1200/1200 [566/566]	1200/1200 [566/566]	1200/1200 [566/566]
AHRI Net Cooling Capacity Btu [kW]	36,200 [10.61]	36,200 [10.61]	36,200 [10.61]	36,200 [10.61]
Net Sensible Capacity Btu [kW]	27,000 [7.91]	27,000 [7.91]	27,000 [7.91]	27,000 [7.91]
Net Latent Capacity Btu [kW]	9,200 [2.7]	9,200 [2.7]	9,200 [2.7]	9,200 [2.7]
Net System Power kW	3.1	3.1	3.1	3.1
<b>Heating Performance (Heat Pumps)</b>				
High Temp. Btuh [kW] Rating	34,400 [10.08]	34,400 [10.08]	34,400 [10.08]	34,400 [10.08]
System Power KW / COP	2.94/3.4	2.94/3.4	2.94/3.4	2.94/3.4
Low Temp. Btuh [kW] Rating	19,600 [5.74]	19,600 [5.74]	19,600 [5.74]	19,600 [5.74]
System Power KW / COP	2.72/2.1	2.72/2.1	2.72/2.1	2.72/2.1
HSPF (Btu/Watts-hr)	7.699999809	7.699999809	7.699999809	7.699999809
<b>Compressor</b>				
No./Type	1/Scroll	1/Scroll	1/Scroll	1/Scroll
<b>Outdoor Sound Rating (dB)<sup>5</sup></b>	83	83	83	83
<b>Outdoor Coil - Fin Type</b>	Louvered	Louvered	Louvered	Louvered
Tube Type	Rifled	Rifled	Rifled	Rifled
Tube Size in. [mm] OD	0.375 [9.5]	0.375 [9.5]	0.375 [9.5]	0.375 [9.5]
Face Area sq. ft. [sq. m]	16.89 [1.57]	16.89 [1.57]	16.89 [1.57]	16.89 [1.57]
Rows / FPI [FPcm]	1 / 22 [9]	1 / 22 [9]	1 / 22 [9]	1 / 22 [9]
Refrigerant Control	TX Valves	TX Valves	TX Valves	TX Valves
<b>Indoor Coil - Fin Type</b>	Louvered	Louvered	Louvered	Louvered
Tube Type	Rifled	Rifled	Rifled	Rifled
Tube Size in. [mm]	0.375 [9.5]	0.375 [9.5]	0.375 [9.5]	0.375 [9.5]
Face Area sq. ft. [sq. m]	5.16 [0.48]	5.16 [0.48]	5.16 [0.48]	5.16 [0.48]
Rows / FPI [FPcm]	3 / 13 [5]	3 / 13 [5]	3 / 13 [5]	3 / 13 [5]
Refrigerant Control	TX Valves	TX Valves	TX Valves	TX Valves
Drain Connection No./Size in. [mm]	1/1 [25.4]	1/1 [25.4]	1/1 [25.4]	1/1 [25.4]
<b>Outdoor Fan - Type</b>	Propeller	Propeller	Propeller	Propeller
No. Used/Diameter in. [mm]	1/24 [609.6]	1/24 [609.6]	1/24 [609.6]	1/24 [609.6]
Drive Type/No. Speeds	Direct/1	Direct/1	Direct/1	Direct/1
CFM [L/s]	4000 [1888]	4000 [1888]	4000 [1888]	4000 [1888]
No. Motors/HP	1 at 1/3 HP	1 at 1/3 HP	1 at 1/3 HP	1 at 1/3 HP
Motor RPM	1075	1075	1075	1075
<b>Indoor Fan - Type</b>	FC Centrifugal	FC Centrifugal	FC Centrifugal	FC Centrifugal
No. Used/Diameter in. [mm]	1/10x10 [254x254]	1/10x10 [254x254]	1/10x10 [254x254]	1/10x10 [254x254]
Drive Type/No. Speeds	Belt/Variable	Belt/Variable	Belt/Variable	Belt/Variable
No. Motors	1	1	1	1
Motor HP	1/2	3/4	1/2	3/4
Motor RPM	1725	1725	1725	1725
Motor Frame Size	56	56	56	56
<b>Filter - Type</b>	Disposable	Disposable	Disposable	Disposable
Furnished	Yes	Yes	Yes	Yes
(NO.) Size Recommended in. [mm x mm x mm]	(2)1x25x16 [25x635x406]	(2)1x25x16 [25x635x406]	(2)1x25x16 [25x635x406]	(2)1x25x16 [25x635x406]
<b>Refrigerant Charge Oz. [g]</b>	116 [3289]	116 [3289]	116 [3289]	116 [3289]
<b>Weights</b>				
Net Weight lbs. [kg]	517 [235]	517 [235]	517 [235]	517 [235]
Ship Weight lbs. [kg]	532 [241]	532 [241]	532 [241]	532 [241]

### NOTES:

- Cooling Performance is rated at 95° F ambient, 80° F entering dry bulb, 67° F entering wet bulb. Gross capacity does not include the effect of fan motor heat. AHRI capacity is net and includes the effect of fan motor heat. Units are suitable for operation to ±20% of nominal cfm. Units are certified in accordance with the Unitary Air Conditioner Equipment certification program, which is based on AHRI Standard 210/240 or 360.
- EER and/or SEER are rated at AHRI conditions and in accordance with DOE test procedures.
- Outdoor Sound Rating shown is tested in accordance with AHRI Standard 270.

# GENERAL DATA - RJNL-C MODELS

## NOMINAL SIZES 3-6 TONS [10.6-21.1 kW]

Model RJNL - Series	C042CL	C042CM	C042DL	C042DM
<b>Cooling performance<sup>1</sup></b>				<b>Continued -&gt;</b>
Gross Cooling Capacity Btu [kW]	44,000 [12.89]	44,000 [12.89]	44,000 [12.89]	44,000 [12.89]
EER, SEER <sup>2</sup>	11.2/13	11.2/13	11.2/13	11.2/13
Nominal CFM/AHRI Rated CFM [L/s]	1400/1400 [661/661]	1400/1400 [661/661]	1400/1400 [661/661]	1400/1400 [661/661]
AHRI Net Cooling Capacity Btu [kW]	42,000 [12.31]	42,000 [12.31]	42,000 [12.31]	42,000 [12.31]
Net Sensible Capacity Btu [kW]	31,200 [9.14]	31,200 [9.14]	31,200 [9.14]	31,200 [9.14]
Net Latent Capacity Btu [kW]	10,800 [3.16]	10,800 [3.16]	10,800 [3.16]	10,800 [3.16]
Net System Power kW	3.74	3.74	3.74	3.74
<b>Heating Performance (Heat Pumps)</b>				
High Temp. Btuh [kW] Rating	41,000 [12.01]	41,000 [12.01]	41,000 [12.01]	41,000 [12.01]
System Power KW / COP	3.38/3.5	3.38/3.5	3.38/3.5	3.38/3.5
Low Temp. Btuh [kW] Rating	24,400 [7.15]	24,400 [7.15]	24,400 [7.15]	24,400 [7.15]
System Power KW / COP	3.12/2.3	3.12/2.3	3.12/2.3	3.12/2.3
HSPF (Btu/Watts-hr)	7.699999809	7.699999809	7.699999809	7.699999809
<b>Compressor</b>				
No./Type	1/Scroll	1/Scroll	1/Scroll	1/Scroll
<b>Outdoor Sound Rating (dB)<sup>5</sup></b>	83	83	83	83
<b>Outdoor Coil - Fin Type</b>	Louvered	Louvered	Louvered	Louvered
Tube Type	Rifled	Rifled	Rifled	Rifled
Tube Size in. [mm] OD	0.375 [9.5]	0.375 [9.5]	0.375 [9.5]	0.375 [9.5]
Face Area sq. ft. [sq. m]	16.89 [1.57]	16.89 [1.57]	16.89 [1.57]	16.89 [1.57]
Rows / FPI [FPcm]	1 / 22 [9]	1 / 22 [9]	1 / 22 [9]	1 / 22 [9]
Refrigerant Control	TX Valves	TX Valves	TX Valves	TX Valves
<b>Indoor Coil - Fin Type</b>	Louvered	Louvered	Louvered	Louvered
Tube Type	Rifled	Rifled	Rifled	Rifled
Tube Size in. [mm]	0.375 [9.5]	0.375 [9.5]	0.375 [9.5]	0.375 [9.5]
Face Area sq. ft. [sq. m]	5.16 [0.48]	5.16 [0.48]	5.16 [0.48]	5.16 [0.48]
Rows / FPI [FPcm]	3 / 13 [5]	3 / 13 [5]	3 / 13 [5]	3 / 13 [5]
Refrigerant Control	TX Valves	TX Valves	TX Valves	TX Valves
Drain Connection No./Size in. [mm]	1/1 [25.4]	1/1 [25.4]	1/1 [25.4]	1/1 [25.4]
<b>Outdoor Fan - Type</b>	Propeller	Propeller	Propeller	Propeller
No. Used/Diameter in. [mm]	1/24 [609.6]	1/24 [609.6]	1/24 [609.6]	1/24 [609.6]
Drive Type/No. Speeds	Direct/1	Direct/1	Direct/1	Direct/1
CFM [L/s]	4000 [1888]	4000 [1888]	4000 [1888]	4000 [1888]
No. Motors/HP	1 at 1/3 HP	1 at 1/3 HP	1 at 1/3 HP	1 at 1/3 HP
Motor RPM	1075	1075	1075	1075
<b>Indoor Fan - Type</b>	FC Centrifugal	FC Centrifugal	FC Centrifugal	FC Centrifugal
No. Used/Diameter in. [mm]	1/10x10 [254x254]	1/10x10 [254x254]	1/10x10 [254x254]	1/10x10 [254x254]
Drive Type/No. Speeds	Belt/Variable	Belt/Variable	Belt/Variable	Belt/Variable
No. Motors	1	1	1	1
Motor HP	1/2	3/4	1/2	3/4
Motor RPM	1725	1725	1725	1725
Motor Frame Size	56	56	56	56
<b>Filter - Type</b>	Disposable	Disposable	Disposable	Disposable
Furnished	Yes	Yes	Yes	Yes
(NO.) Size Recommended in. [mm x mm x mm]	(2)1x25x16 [25x635x406]	(2)1x25x16 [25x635x406]	(2)1x25x16 [25x635x406]	(2)1x25x16 [25x635x406]
<b>Refrigerant Charge Oz. [g]</b>	120 [3402]	120 [3402]	120 [3402]	120 [3402]
<b>Weights</b>				
Net Weight lbs. [kg]	521 [236]	521 [236]	521 [236]	521 [236]
Ship Weight lbs. [kg]	536 [243]	536 [243]	536 [243]	536 [243]

### NOTES:

- Cooling Performance is rated at 95° F ambient, 80° F entering dry bulb, 67° F entering wet bulb. Gross capacity does not include the effect of fan motor heat. AHRI capacity is net and includes the effect of fan motor heat. Units are suitable for operation to ±20% of nominal cfm. Units are certified in accordance with the Unitary Air Conditioner Equipment certification program, which is based on AHRI Standard 210/240 or 360.
- EER and/or SEER are rated at AHRI conditions and in accordance with DOE test procedures.
- Outdoor Sound Rating shown is tested in accordance with AHRI Standard 270.

# GENERAL DATA - RJNL-C MODELS

## NOMINAL SIZES 3-6 TONS [10.6-21.1 kW]

Model RJNL - Series	C048CL	C048CM	C048DL	C048DM
<b>Cooling performance<sup>1</sup></b>				<b>Continued -&gt;</b>
Gross Cooling Capacity Btu [kW]	50,000 [14.65]	50,000 [14.65]	50,000 [14.65]	50,000 [14.65]
EER, SEER <sup>2</sup>	11.2/13	11.2/13	11.2/13	11.2/13
Nominal CFM/AHRI Rated CFM [L/s]	1600/1600 [755/755]	1600/1600 [755/755]	1600/1600 [755/755]	1600/1600 [755/755]
AHRI Net Cooling Capacity Btu [kW]	47,500 [13.92]	47,500 [13.92]	47,500 [13.92]	47,500 [13.92]
Net Sensible Capacity Btu [kW]	35,700 [10.46]	35,700 [10.46]	35,700 [10.46]	35,700 [10.46]
Net Latent Capacity Btu [kW]	11,800 [3.46]	11,800 [3.46]	11,800 [3.46]	11,800 [3.46]
Net System Power kW	4.22	4.22	4.22	4.22
<b>Heating Performance (Heat Pumps)</b>				
High Temp. Btuh [kW] Rating	49,000 [14.36]	49,000 [14.36]	49,000 [14.36]	49,000 [14.36]
System Power KW / COP	3.93/3.6	3.93/3.6	3.93/3.6	3.93/3.6
Low Temp. Btuh [kW] Rating	29,000 [8.5]	29,000 [8.5]	29,000 [8.5]	29,000 [8.5]
System Power KW / COP	3.63/2.3	3.63/2.3	3.63/2.3	3.63/2.3
HSPF (Btu/Watts-hr)	7.699999809	7.699999809	7.699999809	7.699999809
<b>Compressor</b>				
No./Type	1/Scroll	1/Scroll	1/Scroll	1/Scroll
<b>Outdoor Sound Rating (dB)<sup>5</sup></b>	83	83	83	83
<b>Outdoor Coil - Fin Type</b>	Louvered	Louvered	Louvered	Louvered
Tube Type	Rifled	Rifled	Rifled	Rifled
Tube Size in. [mm] OD	0.375 [9.5]	0.375 [9.5]	0.375 [9.5]	0.375 [9.5]
Face Area sq. ft. [sq. m]	16.56 [1.54]	16.56 [1.54]	16.56 [1.54]	16.56 [1.54]
Rows / FPI [FPcm]	2 / 22 [9]	2 / 22 [9]	2 / 22 [9]	2 / 22 [9]
Refrigerant Control	TX Valves	TX Valves	TX Valves	TX Valves
<b>Indoor Coil - Fin Type</b>	Louvered	Louvered	Louvered	Louvered
Tube Type	Rifled	Rifled	Rifled	Rifled
Tube Size in. [mm]	0.375 [9.5]	0.375 [9.5]	0.375 [9.5]	0.375 [9.5]
Face Area sq. ft. [sq. m]	5.16 [0.48]	5.16 [0.48]	5.16 [0.48]	5.16 [0.48]
Rows / FPI [FPcm]	4 / 13 [5]	4 / 13 [5]	4 / 13 [5]	4 / 13 [5]
Refrigerant Control	TX Valves	TX Valves	TX Valves	TX Valves
Drain Connection No./Size in. [mm]	1/1 [25.4]	1/1 [25.4]	1/1 [25.4]	1/1 [25.4]
<b>Outdoor Fan - Type</b>	Propeller	Propeller	Propeller	Propeller
No. Used/Diameter in. [mm]	1/24 [609.6]	1/24 [609.6]	1/24 [609.6]	1/24 [609.6]
Drive Type/No. Speeds	Direct/1	Direct/1	Direct/1	Direct/1
CFM [L/s]	4000 [1888]	4000 [1888]	4000 [1888]	4000 [1888]
No. Motors/HP	1 at 1/3 HP	1 at 1/3 HP	1 at 1/3 HP	1 at 1/3 HP
Motor RPM	1075	1075	1075	1075
<b>Indoor Fan - Type</b>	FC Centrifugal	FC Centrifugal	FC Centrifugal	FC Centrifugal
No. Used/Diameter in. [mm]	1/10x10 [254x254]	1/10x10 [254x254]	1/10x10 [254x254]	1/10x10 [254x254]
Drive Type/No. Speeds	Belt/Variable	Belt/Variable	Belt/Variable	Belt/Variable
No. Motors	1	1	1	1
Motor HP	1/2	3/4	1/2	3/4
Motor RPM	1725	1725	1725	1725
Motor Frame Size	56	56	56	56
<b>Filter - Type</b>	Disposable	Disposable	Disposable	Disposable
Furnished	Yes	Yes	Yes	Yes
(NO.) Size Recommended in. [mm x mm x mm]	(2)1x25x16 [25x635x406]	(2)1x25x16 [25x635x406]	(2)1x25x16 [25x635x406]	(2)1x25x16 [25x635x406]
<b>Refrigerant Charge Oz. [g]</b>	187 [5301]	187 [5301]	187 [5301]	187 [5301]
<b>Weights</b>				
Net Weight lbs. [kg]	535 [243]	535 [243]	535 [243]	535 [243]
Ship Weight lbs. [kg]	550 [249]	550 [249]	550 [249]	550 [249]

### NOTES:

- Cooling Performance is rated at 95° F ambient, 80° F entering dry bulb, 67° F entering wet bulb. Gross capacity does not include the effect of fan motor heat. AHRI capacity is net and includes the effect of fan motor heat. Units are suitable for operation to ±20% of nominal cfm. Units are certified in accordance with the Unitary Air Conditioner Equipment certification program, which is based on AHRI Standard 210/240 or 360.
- EER and/or SEER are rated at AHRI conditions and in accordance with DOE test procedures.
- Outdoor Sound Rating shown is tested in accordance with AHRI Standard 270.

# GENERAL DATA - RJNL-C MODELS

## NOMINAL SIZES 3-6 TONS [10.6-21.1 kW]

Model RJNL - Series	C060CL	C060CM	C060DL	C060DM
<b>Cooling performance<sup>1</sup></b>				<b>Continued -&gt;</b>
Gross Cooling Capacity Btu [kW]	61,500 [18.02]	61,500 [18.02]	61,500 [18.02]	61,500 [18.02]
EER, SEER <sup>2</sup>	11.5/13	11.5/13	11.5/13	11.5/13
Nominal CFM/AHRI Rated CFM [L/s]	2000/2000 [944/944]	2000/2000 [944/944]	2000/2000 [944/944]	2000/2000 [944/944]
AHRI Net Cooling Capacity Btu [kW]	59,000 [17.29]	59,000 [17.29]	59,000 [17.29]	59,000 [17.29]
Net Sensible Capacity Btu [kW]	44,050 [12.91]	44,050 [12.91]	44,050 [12.91]	44,050 [12.91]
Net Latent Capacity Btu [kW]	14,950 [4.38]	14,950 [4.38]	14,950 [4.38]	14,950 [4.38]
Net System Power kW	5.04	5.04	5.04	5.04
<b>Heating Performance (Heat Pumps)</b>				
High Temp. Btuh [kW] Rating	60,000 [17.58]	60,000 [17.58]	60,000 [17.58]	60,000 [17.58]
System Power KW / COP	4.78/3.6	4.78/3.6	4.78/3.6	4.78/3.6
Low Temp. Btuh [kW] Rating	35,800 [10.49]	35,800 [10.49]	35,800 [10.49]	35,800 [10.49]
System Power KW / COP	4.31/2.4	4.31/2.4	4.31/2.4	4.31/2.4
HSPF (Btu/Watts-hr)	7.699999809	7.699999809	7.699999809	7.699999809
<b>Compressor</b>				
No./Type	1/Scroll	1/Scroll	1/Scroll	1/Scroll
<b>Outdoor Sound Rating (dB)<sup>5</sup></b>	83	83	83	83
<b>Outdoor Coil - Fin Type</b>	Louvered	Louvered	Louvered	Louvered
Tube Type	Rifled	Rifled	Rifled	Rifled
Tube Size in. [mm] OD	0.375 [9.5]	0.375 [9.5]	0.375 [9.5]	0.375 [9.5]
Face Area sq. ft. [sq. m]	16.56 [1.54]	16.56 [1.54]	16.56 [1.54]	16.56 [1.54]
Rows / FPI [FPcm]	2 / 22 [9]	2 / 22 [9]	2 / 22 [9]	2 / 22 [9]
Refrigerant Control	TX Valves	TX Valves	TX Valves	TX Valves
<b>Indoor Coil - Fin Type</b>	Louvered	Louvered	Louvered	Louvered
Tube Type	Rifled	Rifled	Rifled	Rifled
Tube Size in. [mm]	0.375 [9.5]	0.375 [9.5]	0.375 [9.5]	0.375 [9.5]
Face Area sq. ft. [sq. m]	5.16 [0.48]	5.16 [0.48]	5.16 [0.48]	5.16 [0.48]
Rows / FPI [FPcm]	4 / 13 [5]	4 / 13 [5]	4 / 13 [5]	4 / 13 [5]
Refrigerant Control	TX Valves	TX Valves	TX Valves	TX Valves
Drain Connection No./Size in. [mm]	1/1 [25.4]	1/1 [25.4]	1/1 [25.4]	1/1 [25.4]
<b>Outdoor Fan - Type</b>	Propeller	Propeller	Propeller	Propeller
No. Used/Diameter in. [mm]	1/24 [609.6]	1/24 [609.6]	1/24 [609.6]	1/24 [609.6]
Drive Type/No. Speeds	Direct/1	Direct/1	Direct/1	Direct/1
CFM [L/s]	4000 [1888]	4000 [1888]	4000 [1888]	4000 [1888]
No. Motors/HP	1 at 1/3 HP	1 at 1/3 HP	1 at 1/3 HP	1 at 1/3 HP
Motor RPM	1075	1075	1075	1075
<b>Indoor Fan - Type</b>	FC Centrifugal	FC Centrifugal	FC Centrifugal	FC Centrifugal
No. Used/Diameter in. [mm]	1/10x10 [254x254]	1/10x10 [254x254]	1/10x10 [254x254]	1/10x10 [254x254]
Drive Type/No. Speeds	Belt/Variable	Belt/Variable	Belt/Variable	Belt/Variable
No. Motors	1	1	1	1
Motor HP	3/4	1	3/4	1
Motor RPM	1725	1725	1725	1725
Motor Frame Size	56	56	56	56
<b>Filter - Type</b>	Disposable	Disposable	Disposable	Disposable
Furnished	Yes	Yes	Yes	Yes
(NO.) Size Recommended in. [mm x mm x mm]	(2)1x25x16 [25x635x406]	(2)1x25x16 [25x635x406]	(2)1x25x16 [25x635x406]	(2)1x25x16 [25x635x406]
<b>Refrigerant Charge Oz. [g]</b>	197 [5585]	197 [5585]	197 [5585]	197 [5585]
<b>Weights</b>				
Net Weight lbs. [kg]	565 [256]	565 [256]	565 [256]	565 [256]
Ship Weight lbs. [kg]	580 [263]	580 [263]	580 [263]	580 [263]

### NOTES:

- Cooling Performance is rated at 95° F ambient, 80° F entering dry bulb, 67° F entering wet bulb. Gross capacity does not include the effect of fan motor heat. AHRI capacity is net and includes the effect of fan motor heat. Units are suitable for operation to ±20% of nominal cfm. Units are certified in accordance with the Unitary Air Conditioner Equipment certification program, which is based on AHRI Standard 210/240 or 360.
- EER and/or SEER are rated at AHRI conditions and in accordance with DOE test procedures.
- Outdoor Sound Rating shown is tested in accordance with AHRI Standard 270.



# GENERAL DATA - RJNL-C MODELS

## NOMINAL SIZES 3-6 TONS [10.6-21.1 kW]

Model RJNL - Series	C072CL	C072CM	C072DL	C072DM
<b>Cooling performance<sup>1</sup></b>				<b>Continued -&gt;</b>
Gross Cooling Capacity Btu [kW]	73,000 [21.39]	73,000 [21.39]	73,000 [21.39]	73,000 [21.39]
EER, SEER <sup>2</sup>	11/NA	11/NA	11/NA	11/NA
Nominal CFM/AHRI Rated CFM [L/s]	2400/2125 [1133/1003]	2400/2125 [1133/1003]	2400/2125 [1133/1003]	2400/2125 [1133/1003]
AHRI Net Cooling Capacity Btu [kW]	70,000 [20.51]	70,000 [20.51]	70,000 [20.51]	70,000 [20.51]
Net Sensible Capacity Btu [kW]	50,700 [14.85]	50,700 [14.85]	50,700 [14.85]	50,700 [14.85]
Integrated Part Load Value <sup>3</sup>	19,300 [5.65]	19,300 [5.65]	19,300 [5.65]	19,300 [5.65]
Net Latent Capacity Btu [kW]	N/A	N/A	N/A	N/A
Net System Power kW	6.37	6.37	6.37	6.37
<b>Heating Performance (Heat Pumps)</b>				
High Temp. Btuh [kW] Rating	68,000 [19.92]	68,000 [19.92]	68,000 [19.92]	68,000 [19.92]
System Power KW / COP	5.79/3.44	5.79/3.44	5.79/3.44	5.79/3.44
Low Temp. Btuh [kW] Rating	41,000 [12.01]	41,000 [12.01]	41,000 [12.01]	41,000 [12.01]
System Power KW / COP	5.22/2.3	5.22/2.3	5.22/2.3	5.22/2.3
<b>Compressor</b>				
No./Type	1/Scroll	1/Scroll	1/Scroll	1/Scroll
<b>Outdoor Sound Rating (dB)<sup>5</sup></b>	83	83	83	83
<b>Outdoor Coil - Fin Type</b>	Louvered	Louvered	Louvered	Louvered
Tube Type	Rifled	Rifled	Rifled	Rifled
Tube Size in. [mm] OD	0.375 [9.5]	0.375 [9.5]	0.375 [9.5]	0.375 [9.5]
Face Area sq. ft. [sq. m]	16.56 [1.54]	16.56 [1.54]	16.56 [1.54]	16.56 [1.54]
Rows / FPI [FPcm]	2/22 [9]	2/22 [9]	2/22 [9]	2/22 [9]
Refrigerant Control	TX Valves	TX Valves	TX Valves	TX Valves
<b>Indoor Coil - Fin Type</b>	Louvered	Louvered	Louvered	Louvered
Tube Type	Rifled	Rifled	Rifled	Rifled
Tube Size in. [mm]	0.375 [9.5]	0.375 [9.5]	0.375 [9.5]	0.375 [9.5]
Face Area sq. ft. [sq. m]	6.5 [0.6]	6.5 [0.6]	6.5 [0.6]	6.5 [0.6]
Rows / FPI [FPcm]	4 / 13 [5]	4 / 13 [5]	4 / 13 [5]	4 / 13 [5]
Refrigerant Control	TX Valves	TX Valves	TX Valves	TX Valves
Drain Connection No./Size in. [mm]	1/1 [25.4]	1/1 [25.4]	1/1 [25.4]	1/1 [25.4]
<b>Outdoor Fan - Type</b>	Propeller	Propeller	Propeller	Propeller
No. Used/Diameter in. [mm]	1/24 [609.6]	1/24 [609.6]	1/24 [609.6]	1/24 [609.6]
Drive Type/No. Speeds	Direct/1	Direct/1	Direct/1	Direct/1
CFM [L/s]	4000 [1888]	4000 [1888]	4000 [1888]	4000 [1888]
No. Motors/HP	1 at 1/3 HP	1 at 1/3 HP	1 at 1/3 HP	1 at 1/3 HP
Motor RPM	1075	1075	1075	1075
<b>Indoor Fan - Type</b>	FC Centrifugal	FC Centrifugal	FC Centrifugal	FC Centrifugal
No. Used/Diameter in. [mm]	1/11x11 [279x279]	1/11x11 [279x279]	1/11x11 [279x279]	1/11x11 [279x279]
Drive Type/No. Speeds	Belt/Variable	Belt/Variable	Belt/Variable	Belt/Variable
No. Motors	1	1	1	1
Motor HP	1 1/2	1 1/2	1 1/2	1 1/2
Motor RPM	1725	1725	1725	1725
Motor Frame Size	56	56	56	56
<b>Filter - Type</b>	Disposable	Disposable	Disposable	Disposable
Furnished	Yes	Yes	Yes	Yes
(NO.) Size Recommended in. [mm x mm x mm]	(2)1x16x16 [25x406x406]	(2)1x16x16 [25x406x406]	(2)1x16x16 [25x406x406]	(2)1x16x16 [25x406x406]
<b>Refrigerant Charge Oz. [g]</b>	221 [6265]	221 [6265]	221 [6265]	221 [6265]
<b>Weights</b>				
Net Weight lbs. [kg]	620 [281]	620 [281]	620 [281]	620 [281]
Ship Weight lbs. [kg]	635 [288]	635 [288]	635 [288]	635 [288]

### NOTES:

- Cooling Performance is rated at 95° F ambient, 80° F entering dry bulb, 67° F entering wet bulb. Gross capacity does not include the effect of fan motor heat. AHRI capacity is net and includes the effect of fan motor heat. Units are suitable for operation to ±20% of nominal cfm. Units are certified in accordance with the Unitary Air Conditioner Equipment certification program, which is based on AHRI Standard 210/240 or 360.
- EER and/or SEER are rated at AHRI conditions and in accordance with DOE test procedures.
- Outdoor Sound Rating shown is tested in accordance with AHRI Standard 270.

# GENERAL DATA - RJPL-C MODELS

## NOMINAL SIZES 3-6 TONS [10.6-21.1 kW]

Model RJPL - Series	C036CL	C036CM	C036DL	C036DM
<b>Cooling performance<sup>1</sup></b>				<b>Continued -&gt;</b>
Gross Cooling Capacity Btu [kW]	38,500 [11.28]	38,500 [11.28]	38,500 [11.28]	38,500 [11.28]
EER, SEER <sup>2</sup>	12/14	12/14	12/14	12/14
Nominal CFM/AHRI Rated CFM [L/s]	1200/1200 [566/566]	1200/1200 [566/566]	1200/1200 [566/566]	1200/1200 [566/566]
AHRI Net Cooling Capacity Btu [kW]	36,800 [10.78]	36,800 [10.78]	36,800 [10.78]	36,800 [10.78]
Net Sensible Capacity Btu [kW]	27,200 [7.97]	27,200 [7.97]	27,200 [7.97]	27,200 [7.97]
Net Latent Capacity Btu [kW]	9,600 [2.81]	9,600 [2.81]	9,600 [2.81]	9,600 [2.81]
Net System Power kW	2.99	2.99	2.99	2.99
<b>Heating Performance (Heat Pumps)</b>				
High Temp. Btuh [kW] Rating	33,600 [9.84]	33,600 [9.84]	33,600 [9.84]	33,600 [9.84]
System Power KW / COP	2.79/3.48	2.79/3.48	2.79/3.48	2.79/3.48
Low Temp. Btuh [kW] Rating	19,400 [5.68]	19,400 [5.68]	19,400 [5.68]	19,400 [5.68]
System Power KW / COP	2.56/2.22	2.56/2.22	2.56/2.22	2.56/2.22
HSPF (Btu/Watts-hr)	8	8	8	8
<b>Compressor</b>				
No./Type	1/Scroll	1/Scroll	1/Scroll	1/Scroll
<b>Outdoor Sound Rating (dB)<sup>5</sup></b>	83	83	83	83
<b>Outdoor Coil - Fin Type</b>	Louvered	Louvered	Louvered	Louvered
Tube Type	Rifled	Rifled	Rifled	Rifled
Tube Size in. [mm] OD	0.375 [9.5]	0.375 [9.5]	0.375 [9.5]	0.375 [9.5]
Face Area sq. ft. [sq. m]	16.89 [1.57]	16.89 [1.57]	16.89 [1.57]	16.89 [1.57]
Rows / FPI [FPcm]	1 / 22 [9]	1 / 22 [9]	1 / 22 [9]	1 / 22 [9]
Refrigerant Control	TX Valves	TX Valves	TX Valves	TX Valves
<b>Indoor Coil - Fin Type</b>	Louvered	Louvered	Louvered	Louvered
Tube Type	Rifled	Rifled	Rifled	Rifled
Tube Size in. [mm]	0.375 [9.5]	0.375 [9.5]	0.375 [9.5]	0.375 [9.5]
Face Area sq. ft. [sq. m]	5.16 [0.48]	5.16 [0.48]	5.16 [0.48]	5.16 [0.48]
Rows / FPI [FPcm]	3 / 13 [5]	3 / 13 [5]	3 / 13 [5]	3 / 13 [5]
Refrigerant Control	TX Valves	TX Valves	TX Valves	TX Valves
Drain Connection No./Size in. [mm]	1/1 [25.4]	1/1 [25.4]	1/1 [25.4]	1/1 [25.4]
<b>Outdoor Fan - Type</b>	Propeller	Propeller	Propeller	Propeller
No. Used/Diameter in. [mm]	1/24 [609.6]	1/24 [609.6]	1/24 [609.6]	1/24 [609.6]
Drive Type/No. Speeds	Direct/1	Direct/1	Direct/1	Direct/1
CFM [L/s]	4000 [1888]	4000 [1888]	4000 [1888]	4000 [1888]
No. Motors/HP	1 at 1/3 HP	1 at 1/3 HP	1 at 1/3 HP	1 at 1/3 HP
Motor RPM	1075	1075	1075	1075
<b>Indoor Fan - Type</b>	FC Centrifugal	FC Centrifugal	FC Centrifugal	FC Centrifugal
No. Used/Diameter in. [mm]	1/10x10 [254x254]	1/10x10 [254x254]	1/10x10 [254x254]	1/10x10 [254x254]
Drive Type/No. Speeds	Belt/Variable	Belt/Variable	Belt/Variable	Belt/Variable
No. Motors	1	1	1	1
Motor HP	1/2	3/4	1/2	3/4
Motor RPM	1725	1725	1725	1725
Motor Frame Size	56	56	56	56
<b>Filter - Type</b>	Disposable	Disposable	Disposable	Disposable
Furnished	Yes	Yes	Yes	Yes
(NO.) Size Recommended in. [mm x mm x mm]	(2)1x25x16 [25x635x406]	(2)1x25x16 [25x635x406]	(2)1x25x16 [25x635x406]	(2)1x25x16 [25x635x406]
<b>Refrigerant Charge Oz. [g]</b>	116 [3289]	116 [3289]	116 [3289]	116 [3289]
<b>Weights</b>				
Net Weight lbs. [kg]	517 [235]	517 [235]	517 [235]	517 [235]
Ship Weight lbs. [kg]	532 [241]	532 [241]	532 [241]	532 [241]

### NOTES:

- Cooling Performance is rated at 95° F ambient, 80° F entering dry bulb, 67° F entering wet bulb. Gross capacity does not include the effect of fan motor heat. AHRI capacity is net and includes the effect of fan motor heat. Units are suitable for operation to ±20% of nominal cfm. Units are certified in accordance with the Unitary Air Conditioner Equipment certification program, which is based on AHRI Standard 210/240 or 360.
- EER and/or SEER are rated at AHRI conditions and in accordance with DOE test procedures.
- Outdoor Sound Rating shown is tested in accordance with AHRI Standard 270.

# GENERAL DATA - RJPL-C MODELS

## NOMINAL SIZES 3-6 TONS [10.6-21.1 kW]

Model RJPL - Series	C042CL	C042CM	C042DL	C042DM
<b>Cooling performance<sup>1</sup></b>				<b>Continued -&gt;</b>
Gross Cooling Capacity Btu [kW]	44,000 [12.89]	44,000 [12.89]	44,000 [12.89]	44,000 [12.89]
EER, SEER <sup>2</sup>	11.6/14	11.6/14	11.6/14	11.6/14
Nominal CFM/AHRI Rated CFM [L/s]	1400/1400 [661/661]	1400/1400 [661/661]	1400/1400 [661/661]	1400/1400 [661/661]
AHRI Net Cooling Capacity Btu [kW]	42,000 [12.31]	42,000 [12.31]	42,000 [12.31]	42,000 [12.31]
Net Sensible Capacity Btu [kW]	31,750 [9.3]	31,750 [9.3]	31,750 [9.3]	31,750 [9.3]
Net Latent Capacity Btu [kW]	10,250 [3]	10,250 [3]	10,250 [3]	10,250 [3]
Net System Power kW	3.64	3.64	3.64	3.64
<b>Heating Performance (Heat Pumps)</b>				
High Temp. Btuh [kW] Rating	40,000 [11.72]	40,000 [11.72]	40,000 [11.72]	40,000 [11.72]
System Power KW / COP	3.23/3.6	3.23/3.6	3.23/3.6	3.23/3.6
Low Temp. Btuh [kW] Rating	24,200 [7.09]	24,200 [7.09]	24,200 [7.09]	24,200 [7.09]
System Power KW / COP	2.94/2.4	2.94/2.4	2.94/2.4	2.94/2.4
HSPF (Btu/Watts-hr)	8	8	8	8
<b>Compressor</b>				
No./Type	1/Scroll	1/Scroll	1/Scroll	1/Scroll
<b>Outdoor Sound Rating (dB)<sup>5</sup></b>	83	83	83	83
<b>Outdoor Coil - Fin Type</b>	Louvered	Louvered	Louvered	Louvered
Tube Type	Rifled	Rifled	Rifled	Rifled
Tube Size in. [mm] OD	0.375 [9.5]	0.375 [9.5]	0.375 [9.5]	0.375 [9.5]
Face Area sq. ft. [sq. m]	16.89 [1.57]	16.89 [1.57]	16.89 [1.57]	16.89 [1.57]
Rows / FPI [FPcm]	1 / 22 [9]	1 / 22 [9]	1 / 22 [9]	1 / 22 [9]
Refrigerant Control	TX Valves	TX Valves	TX Valves	TX Valves
<b>Indoor Coil - Fin Type</b>	Louvered	Louvered	Louvered	Louvered
Tube Type	Rifled	Rifled	Rifled	Rifled
Tube Size in. [mm]	0.375 [9.5]	0.375 [9.5]	0.375 [9.5]	0.375 [9.5]
Face Area sq. ft. [sq. m]	5.16 [0.48]	5.16 [0.48]	5.16 [0.48]	5.16 [0.48]
Rows / FPI [FPcm]	3 / 13 [5]	3 / 13 [5]	3 / 13 [5]	3 / 13 [5]
Refrigerant Control	TX Valves	TX Valves	TX Valves	TX Valves
Drain Connection No./Size in. [mm]	1/1 [25.4]	1/1 [25.4]	1/1 [25.4]	1/1 [25.4]
<b>Outdoor Fan - Type</b>	Propeller	Propeller	Propeller	Propeller
No. Used/Diameter in. [mm]	1/24 [609.6]	1/24 [609.6]	1/24 [609.6]	1/24 [609.6]
Drive Type/No. Speeds	Direct/1	Direct/1	Direct/1	Direct/1
CFM [L/s]	4000 [1888]	4000 [1888]	4000 [1888]	4000 [1888]
No. Motors/HP	1 at 1/3 HP	1 at 1/3 HP	1 at 1/3 HP	1 at 1/3 HP
Motor RPM	1075	1075	1075	1075
<b>Indoor Fan - Type</b>	FC Centrifugal	FC Centrifugal	FC Centrifugal	FC Centrifugal
No. Used/Diameter in. [mm]	1/10x10 [254x254]	1/10x10 [254x254]	1/10x10 [254x254]	1/10x10 [254x254]
Drive Type/No. Speeds	Belt/Variable	Belt/Variable	Belt/Variable	Belt/Variable
No. Motors	1	1	1	1
Motor HP	1/2	3/4	1/2	3/4
Motor RPM	1725	1725	1725	1725
Motor Frame Size	56	56	56	56
<b>Filter - Type</b>	Disposable	Disposable	Disposable	Disposable
Furnished	Yes	Yes	Yes	Yes
(NO.) Size Recommended in. [mm x mm x mm]	(2)1x25x16 [25x635x406]	(2)1x25x16 [25x635x406]	(2)1x25x16 [25x635x406]	(2)1x25x16 [25x635x406]
<b>Refrigerant Charge Oz. [g]</b>	120 [3402]	120 [3402]	120 [3402]	120 [3402]
<b>Weights</b>				
Net Weight lbs. [kg]	521 [236]	521 [236]	521 [236]	521 [236]
Ship Weight lbs. [kg]	536 [243]	536 [243]	536 [243]	536 [243]

### NOTES:

- Cooling Performance is rated at 95° F ambient, 80° F entering dry bulb, 67° F entering wet bulb. Gross capacity does not include the effect of fan motor heat. AHRI capacity is net and includes the effect of fan motor heat. Units are suitable for operation to ±20% of nominal cfm. Units are certified in accordance with the Unitary Air Conditioner Equipment certification program, which is based on AHRI Standard 210/240 or 360.
- EER and/or SEER are rated at AHRI conditions and in accordance with DOE test procedures.
- Outdoor Sound Rating shown is tested in accordance with AHRI Standard 270.

# GENERAL DATA - RJPL-C MODELS

## NOMINAL SIZES 3-6 TONS [10.6-21.1 kW]

Model RJPL - Series	C048CL	C048CM	C048DL	C048DM
<b>Cooling performance<sup>1</sup></b>				<b>Continued -&gt;</b>
Gross Cooling Capacity Btu [kW]	50,000 [14.65]	50,000 [14.65]	50,000 [14.65]	50,000 [14.65]
EER, SEER <sup>2</sup>	11.6/14	11.6/14	11.6/14	11.6/14
Nominal CFM/AHRI Rated CFM [L/s]	1600/1600 [755/755]	1600/1600 [755/755]	1600/1600 [755/755]	1600/1600 [755/755]
AHRI Net Cooling Capacity Btu [kW]	47,500 [13.92]	47,500 [13.92]	47,500 [13.92]	47,500 [13.92]
Net Sensible Capacity Btu [kW]	36,200 [10.61]	36,200 [10.61]	36,200 [10.61]	36,200 [10.61]
Net Latent Capacity Btu [kW]	11,300 [3.31]	11,300 [3.31]	11,300 [3.31]	11,300 [3.31]
Net System Power kW	4.09	4.09	4.09	4.09
<b>Heating Performance (Heat Pumps)</b>				
High Temp. Btuh [kW] Rating	49,000 [14.36]	49,000 [14.36]	49,000 [14.36]	49,000 [14.36]
System Power KW / COP	3.76/3.8	3.76/3.8	3.76/3.8	3.76/3.8
Low Temp. Btuh [kW] Rating	29,800 [8.73]	29,800 [8.73]	29,800 [8.73]	29,800 [8.73]
System Power KW / COP	3.48/2.4	3.48/2.4	3.48/2.4	3.48/2.4
HSPF (Btu/Watts-hr)	8	8	8	8
<b>Compressor</b>				
No./Type	1/Scroll	1/Scroll	1/Scroll	1/Scroll
<b>Outdoor Sound Rating (dB)<sup>5</sup></b>	83	83	83	83
<b>Outdoor Coil - Fin Type</b>	Louvered	Louvered	Louvered	Louvered
Tube Type	Rifled	Rifled	Rifled	Rifled
Tube Size in. [mm] OD	0.375 [9.5]	0.375 [9.5]	0.375 [9.5]	0.375 [9.5]
Face Area sq. ft. [sq. m]	16.56 [1.54]	16.56 [1.54]	16.56 [1.54]	16.56 [1.54]
Rows / FPI [FPcm]	2 / 22 [9]	2 / 22 [9]	2 / 22 [9]	2 / 22 [9]
Refrigerant Control	TX Valves	TX Valves	TX Valves	TX Valves
<b>Indoor Coil - Fin Type</b>	Louvered	Louvered	Louvered	Louvered
Tube Type	Rifled	Rifled	Rifled	Rifled
Tube Size in. [mm]	0.375 [9.5]	0.375 [9.5]	0.375 [9.5]	0.375 [9.5]
Face Area sq. ft. [sq. m]	5.16 [0.48]	5.16 [0.48]	5.16 [0.48]	5.16 [0.48]
Rows / FPI [FPcm]	4 / 13 [5]	4 / 13 [5]	4 / 13 [5]	4 / 13 [5]
Refrigerant Control	TX Valves	TX Valves	TX Valves	TX Valves
Drain Connection No./Size in. [mm]	1/1 [25.4]	1/1 [25.4]	1/1 [25.4]	1/1 [25.4]
<b>Outdoor Fan - Type</b>	Propeller	Propeller	Propeller	Propeller
No. Used/Diameter in. [mm]	1/24 [609.6]	1/24 [609.6]	1/24 [609.6]	1/24 [609.6]
Drive Type/No. Speeds	Direct/1	Direct/1	Direct/1	Direct/1
CFM [L/s]	4000 [1888]	4000 [1888]	4000 [1888]	4000 [1888]
No. Motors/HP	1 at 1/3 HP	1 at 1/3 HP	1 at 1/3 HP	1 at 1/3 HP
Motor RPM	1075	1075	1075	1075
<b>Indoor Fan - Type</b>	FC Centrifugal	FC Centrifugal	FC Centrifugal	FC Centrifugal
No. Used/Diameter in. [mm]	1/10x10 [254x254]	1/10x10 [254x254]	1/10x10 [254x254]	1/10x10 [254x254]
Drive Type/No. Speeds	Belt/Variable	Belt/Variable	Belt/Variable	Belt/Variable
No. Motors	1	1	1	1
Motor HP	1/2	3/4	1/2	3/4
Motor RPM	1725	1725	1725	1725
Motor Frame Size	56	56	56	56
<b>Filter - Type</b>	Disposable	Disposable	Disposable	Disposable
Furnished	Yes	Yes	Yes	Yes
(NO.) Size Recommended in. [mm x mm x mm]	(2)1x25x16 [25x635x406]	(2)1x25x16 [25x635x406]	(2)1x25x16 [25x635x406]	(2)1x25x16 [25x635x406]
<b>Refrigerant Charge Oz. [g]</b>	187 [5301]	187 [5301]	187 [5301]	187 [5301]
<b>Weights</b>				
Net Weight lbs. [kg]	535 [243]	535 [243]	535 [243]	535 [243]
Ship Weight lbs. [kg]	550 [249]	550 [249]	550 [249]	550 [249]

### NOTES:

- Cooling Performance is rated at 95° F ambient, 80° F entering dry bulb, 67° F entering wet bulb. Gross capacity does not include the effect of fan motor heat. AHRI capacity is net and includes the effect of fan motor heat. Units are suitable for operation to ±20% of nominal cfm. Units are certified in accordance with the Unitary Air Conditioner Equipment certification program, which is based on AHRI Standard 210/240 or 360.
- EER and/or SEER are rated at AHRI conditions and in accordance with DOE test procedures.
- Outdoor Sound Rating shown is tested in accordance with AHRI Standard 270.

# GENERAL DATA - RJPL-C MODELS

## NOMINAL SIZES 3-6 TONS [10.6-21.1 kW]

Model RJPL - Series	C060CL	C060CM	C060DL	C060DM
<b>Cooling performance<sup>1</sup></b>				
Gross Cooling Capacity Btu [kW]	61,000 [17.87]	61,000 [17.87]	61,000 [17.87]	61,000 [17.87]
EER, SEER <sup>2</sup>	11.7/14	11.7/14	11.7/14	11.7/14
Nominal CFM/AHRI Rated CFM [L/s]	2000/1850 [944/873]	2000/1850 [944/873]	2000/1850 [944/873]	2000/1850 [944/873]
AHRI Net Cooling Capacity Btu [kW]	59,500 [17.43]	59,500 [17.43]	59,500 [17.43]	59,500 [17.43]
Net Sensible Capacity Btu [kW]	43,600 [12.77]	43,600 [12.77]	43,600 [12.77]	43,600 [12.77]
Net Latent Capacity Btu [kW]	15,900 [4.66]	15,900 [4.66]	15,900 [4.66]	15,900 [4.66]
Net System Power kW	5.05	5.05	5.05	5.05
<b>Heating Performance (Heat Pumps)</b>				
High Temp. Btuh [kW] Rating	59,500 [17.43]	59,500 [17.43]	59,500 [17.43]	59,500 [17.43]
System Power KW / COP	4.8/3.6	4.8/3.6	4.8/3.6	4.8/3.6
Low Temp. Btuh [kW] Rating	36,400 [10.67]	36,400 [10.67]	36,400 [10.67]	36,400 [10.67]
System Power KW / COP	4.47/2.2	4.47/2.2	4.47/2.2	4.47/2.2
HSPF (Btu/Watts-hr)	8	8	8	8
<b>Compressor</b>				
No./Type	1/Scroll	1/Scroll	1/Scroll	1/Scroll
<b>Outdoor Sound Rating (dB)<sup>5</sup></b>				
	83	83	83	83
<b>Outdoor Coil - Fin Type</b>				
Tube Type	Louvered	Louvered	Louvered	Louvered
Tube Size in. [mm] OD	Rifled	Rifled	Rifled	Rifled
Face Area sq. ft. [sq. m]	0.375 [9.5]	0.375 [9.5]	0.375 [9.5]	0.375 [9.5]
Rows / FPI [FPcm]	16.56 [1.54]	16.56 [1.54]	16.56 [1.54]	16.56 [1.54]
Refrigerant Control	2 / 22 [9]	2 / 22 [9]	2 / 22 [9]	2 / 22 [9]
	TX Valves	TX Valves	TX Valves	TX Valves
<b>Indoor Coil - Fin Type</b>				
Tube Type	Louvered	Louvered	Louvered	Louvered
Tube Size in. [mm]	Rifled	Rifled	Rifled	Rifled
Face Area sq. ft. [sq. m]	0.375 [9.5]	0.375 [9.5]	0.375 [9.5]	0.375 [9.5]
Rows / FPI [FPcm]	5.16 [0.48]	5.16 [0.48]	5.16 [0.48]	5.16 [0.48]
Refrigerant Control	4 / 13 [5]	4 / 13 [5]	4 / 13 [5]	4 / 13 [5]
Drain Connection No./Size in. [mm]	TX Valves	TX Valves	TX Valves	TX Valves
	1/1 [25.4]	1/1 [25.4]	1/1 [25.4]	1/1 [25.4]
<b>Outdoor Fan - Type</b>				
No. Used/Diameter in. [mm]	Propeller	Propeller	Propeller	Propeller
Drive Type/No. Speeds	1/24 [609.6]	1/24 [609.6]	1/24 [609.6]	1/24 [609.6]
CFM [L/s]	Direct/1	Direct/1	Direct/1	Direct/1
No. Motors/HP	4000 [1888]	4000 [1888]	4000 [1888]	4000 [1888]
Motor RPM	1 at 1/3 HP	1 at 1/3 HP	1 at 1/3 HP	1 at 1/3 HP
	1075	1075	1075	1075
<b>Indoor Fan - Type</b>				
No. Used/Diameter in. [mm]	FC Centrifugal	FC Centrifugal	FC Centrifugal	FC Centrifugal
Drive Type/No. Speeds	1/10x10 [254x254]	1/10x10 [254x254]	1/10x10 [254x254]	1/10x10 [254x254]
No. Motors	Belt/Variable	Belt/Variable	Belt/Variable	Belt/Variable
Motor HP	1	1	1	1
Motor RPM	3/4	3/4	3/4	3/4
Motor Frame Size	1725	1725	1725	1725
	56	56	56	56
<b>Filter - Type</b>				
Furnished	Disposable	Disposable	Disposable	Disposable
(NO.) Size Recommended in. [mm x mm x mm]	Yes	Yes	Yes	Yes
	(2)1x25x16 [25x635x406]	(2)1x25x16 [25x635x406]	(2)1x25x16 [25x635x406]	(2)1x25x16 [25x635x406]
<b>Refrigerant Charge Oz. [g]</b>				
	197 [5585]	197 [5585]	197 [5585]	197 [5585]
<b>Weights</b>				
Net Weight lbs. [kg]	565 [256]	565 [256]	565 [256]	565 [256]
Ship Weight lbs. [kg]	580 [263]	580 [263]	580 [263]	580 [263]

### NOTES:

- Cooling Performance is rated at 95° F ambient, 80° F entering dry bulb, 67° F entering wet bulb. Gross capacity does not include the effect of fan motor heat. AHRI capacity is net and includes the effect of fan motor heat. Units are suitable for operation to ±20% of nominal cfm. Units are certified in accordance with the Unitary Air Conditioner Equipment certification program, which is based on AHRI Standard 210/240 or 360.
- EER and/or SEER are rated at AHRI conditions and in accordance with DOE test procedures.
- Outdoor Sound Rating shown is tested in accordance with AHRI Standard 270.

# XXVI. MISCELLANEOUS

ELECTRICAL DATA – RJNL-C SERIES									
		C036CL	C036CM	C036DL	C036DM	C042CL	C042CM	C042DL	C042DM
Unit Information	Unit Operating Voltage Range	187-253	187-253	414-506	414-506	187-253	187-253	414-506	414-506
	Volts	208/230	208/230	460	460	208/230	208/230	460	460
	Minimum Circuit Ampacity	18/18	19/19	10	10	22/22	22/22	10	11
	Minimum Overcurrent Protection Device Size	20/20	25/25	15	15	25/25	30/30	15	15
	Maximum Overcurrent Protection Device Size	25/25	25/25	15	15	30/30	35/35	15	15
Compressor Motor	No.	1	1	1	1	1	1	1	1
	Volts	208/230	208/230	460	460	208/230	208/230	460	460
	Phase	3	3	3	3	3	3	3	3
	RPM	3450	3450	3450	3450	3450	3450	3450	3450
	HP, Compressor 1	2 1/2	2 1/2	2 1/2	2 1/2	3	3	3	3
	Amps (RLA), Comp. 1	10.4/10.4	10.4/10.4	5.8	5.8	13.5/13.5	13.5/13.5	6	6
	Amps (LRA), Comp. 1	88/88	88/88	38	38	88/88	88/88	44	44
Condenser Motor	No.	1	1	1	1	1	1	1	1
	Volts	208/230	208/230	460	460	208/230	208/230	460	460
	Phase	1	1	1	1	1	1	1	1
	HP	1/3	1/3	1/3	1/3	1/3	1/3	1/3	1/3
	Amps (FLA, each)	1.5/1.5	1.5/1.5	1	1	1.5/1.5	1.5/1.5	1	1
	Amps (LRA, each)	3/3	3/3	1.9	1.9	3/3	3/3	1.9	1.9
Evaporator Fan	No.	1	1	1	1	1	1	1	1
	Volts	208/230	208/230	460	460	208/230	208/230	460	460
	Phase	3	3	3	3	3	3	3	3
	HP	1/2	3/4	1/2	3/4	1/2	3/4	1/2	3/4
	Amps (FLA, each)	2.2/2.2	3.2/3.2	1.1	1.6	2.2/2.2	3.2/3.2	1.1	1.6
	Amps (LRA, each)	10.6/10.6	16.8/16.8	5.3	8.4	10.6/10.6	16.8/16.8	5.3	8.4

**ELECTRICAL DATA – RJNL-C SERIES**

		C048CL	C048CM	C048DL	C048DM	C060CL	C060CM	C060DL	C060DM
Unit Information	Unit Operating Voltage Range	187-253	187-253	414-506	414-506	187-253	187-253	414-506	414-506
	Volts	208/230	208/230	460	460	208/230	208/230	460	460
	Minimum Circuit Ampacity	22/22	23/23	11	11	26/26	26/26	13	14
	Minimum Overcurrent Protection Device Size	25/25	30/30	15	15	30/30	30/30	15	20
	Maximum Overcurrent Protection Device Size	35/35	35/35	15	15	40/40	40/40	20	20
Compressor Motor	No.	1	1	1	1	1	1	1	1
	Volts	208/230	208/230	460	460	208/230	208/230	460	460
	Phase	3	3	3	3	3	3	3	3
	RPM	3450	3450	3450	3450	3450	3450	3450	3450
	HP, Compressor 1	3 1/2	3 1/2	3 1/2	3 1/2	5	5	5	5
	Amps (RLA), Comp. 1	13.7/13.7	13.7/13.7	6.2	6.2	16/16	16/16	7.8	7.8
	Amps (LRA), Comp. 1	83.1/83.1	83.1/83.1	41	41	110/110	110/110	52	52
Condenser Motor	No.	1	1	1	1	1	1	1	1
	Volts	208/230	208/230	460	460	208/230	208/230	460	460
	Phase	1	1	1	1	1	1	1	1
	HP	1/3	1/3	1/3	1/3	1/3	1/3	1/3	1/3
	Amps (FLA, each)	1.5/1.5	1.5/1.5	1	1	1.5/1.5	1.5/1.5	1	1
	Amps (LRA, each)	3/3	3/3	1.9	1.9	4.7/4.7	4.7/4.7	2.4	2.4
Evaporator Fan	No.	1	1	1	1	1	1	1	1
	Volts	208/230	208/230	460	460	208/230	208/230	460	460
	Phase	3	3	3	3	3	3	3	3
	HP	1/2	3/4	1/2	3/4	3/4	1	3/4	1
	Amps (FLA, each)	2.2/2.2	3.2/3.2	1.1	1.6	3.2/3.2	3.8/3.8	1.6	1.9
	Amps (LRA, each)	10.6/10.6	16.8/16.8	5.3	8.4	16.8/16.8	24/24	8.4	12

ELECTRICAL DATA – RJNL-C SERIES					
		C072CL	C072CM	C072DL	C072DM
Unit Information	Unit Operating Voltage Range	187-253	187-253	414-506	414-506
	Volts	208/230	208/230	460	460
	Minimum Circuit Ampacity	34/34	34/34	17	17
	Minimum Overcurrent Protection Device Size	40/40	40/40	20	20
	Maximum Overcurrent Protection Device Size	50/50	50/50	25	25
Compressor Motor	No.	1	1	1	1
	Volts	208/230	208/230	460	460
	Phase	3	3	3	3
	RPM	3450	3450	3450	3450
	HP, Compressor 1	7 1/2	7 1/2	7 1/2	7 1/2
	Amps (RLA), Comp. 1	19/19	19/19	9.7	9.7
	Amps (LRA), Comp. 1	123/123	123/123	62	62
Condenser Motor	No.	1	1	1	1
	Volts	208/230	208/230	460	460
	Phase	1	1	1	1
	HP	1/3	1/3	1/3	1/3
	Amps (FLA, each)	1.8/1.8	1.8/1.8	1	1
	Amps (LRA, each)	3/3	3/3	2.2	2.2
Evaporator Fan	No.	1	1	1	1
	Volts	208/230	208/230	460	460
	Phase	3	3	3	3
	HP	1 1/2	1 1/2	1 1/2	1 1/2
	Amps (FLA, each)	5.8/5.8	5.8/5.8	2.8	2.8
	Amps (LRA, each)	34/34	34/34	17	17



ELECTRICAL DATA – RJPL-C SERIES									
		C036CL	C036CM	C036DL	C036DM	C042CL	C042CM	C042DL	C042DM
Unit Information	Unit Operating Voltage Range	187-253	187-253	414-506	414-506	187-253	187-253	414-506	414-506
	Volts	208/230	208/230	460	460	208/230	208/230	460	460
	Minimum Circuit Ampacity	18/18	18/18	10	10	22/22	22/22	10	11
	Minimum Overcurrent Protection Device Size	20/20	25/25	15	15	25/25	30/30	15	15
	Maximum Overcurrent Protection Device Size	25/25	25/25	15	15	30/30	35/35	15	15
Compressor Motor	No.	1	1	1	1	1	1	1	1
	Volts	208/230	208/230	460	460	208/230	208/230	460	460
	Phase	3	3	3	3	3	3	3	3
	RPM	3450	3450	3450	3450	3450	3450	3450	3450
	HP, Compressor 1	2 1/2	2 1/2	2 1/2	2 1/2	3	3	3	3
	Amps (RLA), Comp. 1	10.4/10.4	10.4/10.4	5.8	5.8	13.5/13.5	13.5/13.5	6	6
	Amps (LRA), Comp. 1	88/88	88/88	38	38	88/88	88/88	44	44
Condenser Motor	No.	1	1	1	1	1	1	1	1
	Volts	208/230	208/230	460	460	208/230	208/230	460	460
	Phase	1	1	1	1	1	1	1	1
	HP	1/3	1/3	1/3	1/3	1/3	1/3	1/3	1/3
	Amps (FLA, each)	1.5/1.5	1.5/1.5	1	1	1.5/1.5	1.5/1.5	1	1
	Amps (LRA, each)	3/3	3/3	1.9	1.9	3/3	3/3	1.9	1.9
Evaporator Fan	No.	1	1	1	1	1	1	1	1
	Volts	208/230	208/230	460	460	208/230	208/230	460	460
	Phase	3	3	3	3	3	3	3	3
	HP	1/2	3/4	1/2	3/4	1/2	3/4	1/2	3/4
	Amps (FLA, each)	2.8/2.8	3.4/3.4	1.4	1.6	2.8/2.8	3.4/3.4	1.4	1.6
	Amps (LRA, each)	10.6/10.6	16.8/16.8	5.3	8.4	10.6/10.6	16.8/16.8	5.3	8.4

**ELECTRICAL DATA – RJPL-C SERIES**

		C048CL	C048CM	C048DL	C048DM	C060CL	C060CM	C060DL	C060DM
Unit Information	Unit Operating Voltage Range	187-253	187-253	414-506	414-506	187-253	187-253	414-506	414-506
	Volts	208/230	208/230	460	460	208/230	208/230	460	460
	Minimum Circuit Ampacity	22/22	23/23	11	11	26/26	26/26	13	13
	Minimum Overcurrent Protection Device Size	25/25	30/30	15	15	30/30	30/30	15	15
	Maximum Overcurrent Protection Device Size	35/35	35/35	15	15	40/40	40/40	20	20
Compressor Motor	No.	1	1	1	1	1	1	1	1
	Volts	208/230	208/230	460	460	208/230	208/230	460	460
	Phase	3	3	3	3	3	3	3	3
	RPM	3450	3450	3450	3450	3450	3450	3450	3450
	HP, Compressor 1	3 1/2	3 1/2	3 1/2	3 1/2	5	5	5	5
	Amps (RLA), Comp. 1	13.7/13.7	13.7/13.7	6.2	6.2	16/16	16/16	7.8	7.8
	Amps (LRA), Comp. 1	83.1/83.1	83.1/83.1	41	41	110/110	110/110	52	52
Condenser Motor	No.	1	1	1	1	1	1	1	1
	Volts	208/230	208/230	460	460	208/230	208/230	460	460
	Phase	1	1	1	1	1	1	1	1
	HP	1/3	1/3	1/3	1/3	1/3	1/3	1/3	1/3
	Amps (FLA, each)	1.5/1.5	1.5/1.5	1	1	2.2/2.2	2.2/2.2	1	1
	Amps (LRA, each)	3/3	3/3	1.9	1.9	4.7/4.7	4.7/4.7	2.4	2.4
Evaporator Fan	No.	1	1	1	1	1	1	1	1
	Volts	208/230	208/230	460	460	208/230	208/230	460	460
	Phase	3	3	3	3	3	3	3	3
	HP	1/2	3/4	1/2	3/4	3/4	1	3/4	1
	Amps (FLA, each)	2.8/2.8	3.4/3.4	1.4	1.6	3.4/3.4	3.8/3.8	1.6	1.9
	Amps (LRA, each)	10.6/10.6	16.8/16.8	5.3	8.4	16.8/16.8	24/24	8.4	12

ELECTRICAL DATA – RJPL-C SERIES									
		C048CL	C048CM	C048DL	C048DM	C060CL	C060CM	C060DL	C060DM
Unit Information	Unit Operating Voltage Range	187-253	187-253	414-506	414-506	187-253	187-253	414-506	414-506
	Volts	208/230	208/230	460	460	208/230	208/230	460	460
	Minimum Circuit Ampacity	22/22	23/23	11	11	26/26	26/26	13	13
	Minimum Overcurrent Protection Device Size	25/25	30/30	15	15	30/30	30/30	15	15
	Maximum Overcurrent Protection Device Size	35/35	35/35	15	15	40/40	40/40	20	20
Compressor Motor	No.	1	1	1	1	1	1	1	1
	Volts	208/230	208/230	460	460	208/230	208/230	460	460
	Phase	3	3	3	3	3	3	3	3
	RPM	3450	3450	3450	3450	3450	3450	3450	3450
	HP, Compressor 1	3 1/2	3 1/2	3 1/2	3 1/2	5	5	5	5
	Amps (RLA), Comp. 1	13.7/13.7	13.7/13.7	6.2	6.2	16/16	16/16	7.8	7.8
	Amps (LRA), Comp. 1	83.1/83.1	83.1/83.1	41	41	110/110	110/110	52	52
Condenser Motor	No.	1	1	1	1	1	1	1	1
	Volts	208/230	208/230	460	460	208/230	208/230	460	460
	Phase	1	1	1	1	1	1	1	1
	HP	1/3	1/3	1/3	1/3	1/3	1/3	1/3	1/3
	Amps (FLA, each)	1.5/1.5	1.5/1.5	1	1	2.2/2.2	2.2/2.2	1	1
	Amps (LRA, each)	3/3	3/3	1.9	1.9	4.7/4.7	4.7/4.7	2.4	2.4
Evaporator Fan	No.	1	1	1	1	1	1	1	1
	Volts	208/230	208/230	460	460	208/230	208/230	460	460
	Phase	3	3	3	3	3	3	3	3
	HP	1/2	3/4	1/2	3/4	3/4	1	3/4	1
	Amps (FLA, each)	2.8/2.8	3.4/3.4	1.4	1.6	3.4/3.4	3.8/3.8	1.6	1.9
	Amps (LRA, each)	10.6/10.6	16.8/16.8	5.3	8.4	16.8/16.8	24/24	8.4	12

# INDOOR AIRFLOW PERFORMANCE - RJPL/RJNL-C

## 3-3.5 TON

AIR FLOW CFM [L/s]	CAPACITY 3 & 3.5 TON HEAT PUMP (13 SEER) VOLTAGE 208-230, 460 - 3 PHASE																													
	EXTERNAL STATIC PRESSURE - INCHES OF WATER																													
	0.1 [.02]	0.2 [.05]	0.3 [.07]	0.4 [.10]	0.5 [.12]	0.6 [.15]	0.7 [.17]	0.8 [.20]	0.9 [.22]	1.0 [.25]	1.1 [.27]	1.2 [.30]	1.3 [.32]	1.4 [.35]	1.5 [.37]															
900 [425]	—	—	665	290	730	300	780	315	830	330	875	360	920	375	960	380	990	410	1040	445	1080	470	1140	510	1190	540	1235	590		
1000 [472]	—	625	275	680	295	750	310	805	325	850	345	895	375	935	390	970	410	1015	435	1065	465	1100	500	1160	530	1210	560	1255	610	
1100 [519]	—	640	300	710	315	780	325	830	340	875	365	915	390	955	405	990	430	1040	450	1080	485	1115	540	1180	540	1230	600	1270	630	
1200 [566]	—	670	315	735	330	800	345	850	365	890	385	935	410	975	430	1010	450	1060	475	1100	520	1145	560	1200	600	1250	630	1285	660	
1300 [614]	625	315	700	330	770	350	830	370	875	400	915	415	955	440	990	450	1040	495	1085	530	1125	565	1165	590	1220	645	1260	675	1305	710
1400 [661]	655	340	730	365	795	385	850	400	890	430	935	445	975	470	1010	500	1070	540	1110	575	1150	615	1195	645	1230	685	1280	725	1325	760
1500 [708]	685	380	755	390	825	415	870	435	915	450	955	480	990	505	1040	545	1090	590	1135	630	1180	660	1220	720	1255	740	1295	785	1350	820
1600 [755]	730	420	790	435	850	455	890	490	935	505	970	525	1005	550	1075	605	1110	640	1160	680	1200	730	1245	780	1280	800	1325	840	1365	885
1700 [802]	755	465	825	475	875	505	915	535	955	550	985	570	1040	630	1100	685	1135	710	1185	750	1225	800	1265	830	1295	875	1350	910	—	—
1800 [850]	790	500	850	530	890	550	935	570	975	600	1020	650	1080	690	1125	940	1165	770	1210	830	1245	870	1290	910	1310	930	—	—	—	—

NOTE: Bold lines separate L, M and N drives respectively.

DRIVE PACKAGE	L						M						N (FIELD-SUPPLIED)								
MOTOR H.P.	1/2 (3/4 - 575V)						3/4						3/4								
BLOWER SHEAVE	6.9 PITCH DIAMETER						6.4 PITCH DIAMETER						6.4 PITCH DIAMETER								
MOTOR SHEAVE	ADJUSTABLE 2.4 - 3.4 PITCH DIAMETER						ADJUSTABLE 3.4 - 4.4 PITCH DIAMETER						ADJUSTABLE 4.0 - 5.0 PITCH DIAMETER								
TURNS OPEN	0	1	2	3	4	5	6	0	1	2	3	4	5	6	0	1	2	3	4	5	6
RPM	935	875	830	780	730	680	625	1295	1230	1185	1135	1085	1000	955	1090	1030	970	915	860	805	750

Factory sheave settings are shown in bold print.

## 4 TON

AIR FLOW CFM [L/s]	CAPACITY 4 TON HEAT PUMP (13 SEER) VOLTAGE 208-230, 460 - 3 PHASE																													
	EXTERNAL STATIC PRESSURE - INCHES OF WATER																													
	0.1 [.02]	0.2 [.05]	0.3 [.07]	0.4 [.10]	0.5 [.12]	0.6 [.15]	0.7 [.17]	0.8 [.20]	0.9 [.22]	1.0 [.25]	1.1 [.27]	1.2 [.30]	1.3 [.32]	1.4 [.35]	1.5 [.37]															
1200 [566]	—	—	745	340	810	375	865	390	900	400	945	420	1000	440	1040	460	1075	490	1115	540	1170	580	1215	620	1260	650	1300	685		
1300 [614]	—	695	330	770	365	835	395	880	415	920	435	975	455	1010	470	1060	490	1100	530	1140	570	1190	600	1235	640	1270	685	1315	740	
1400 [661]	—	725	350	795	395	855	420	895	435	945	455	995	470	1030	500	1070	520	1115	560	1160	600	1205	640	1250	685	1290	745	1335	810	
1500 [708]	690	360	750	390	820	425	875	450	920	465	970	480	1010	500	1055	560	1100	590	1140	630	1180	660	1230	700	1270	760	1315	815	1350	865
1600 [755]	720	390	780	430	850	460	895	480	945	500	990	530	1035	565	1075	590	1115	635	1160	680	1205	725	1250	770	1290	830	1335	880	1365	935
1700 [802]	750	430	810	465	870	485	920	500	970	530	1015	570	1055	600	1090	645	1140	695	1180	735	1225	790	845	1315	910	1350	960	—	—	
1800 [850]	780	475	840	515	895	540	945	555	990	600	1035	625	1080	660	1115	710	1155	740	1205	800	1250	860	1295	930	1340	995	1365	1030	—	—
1900 [897]	820	520	870	560	925	580	970	600	1015	640	1060	690	1115	750	1145	790	1185	835	1225	880	1275	900	1315	1010	1355	1060	—	—	—	—
2000 [944]	850	585	900	610	950	630	1000	665	1045	715	1090	760	1130	810	1170	865	1205	900	1255	965	1300	1050	1340	1100	1365	1140	—	—	—	—

NOTE: Bold lines separate L, M and N drives respectively.

DRIVE PACKAGE	L						M						N (FIELD-SUPPLIED)								
MOTOR H.P.	1/2 (3/4 - 575V)						3/4						3/4								
BLOWER SHEAVE	6.9 PITCH DIAMETER						6.4 PITCH DIAMETER						6.4 PITCH DIAMETER								
MOTOR SHEAVE	ADJUSTABLE 2.8 - 3.8 PITCH DIAMETER						ADJUSTABLE 3.4 - 4.4 PITCH DIAMETER						ADJUSTABLE 4.0 - 5.0 PITCH DIAMETER								
TURNS OPEN	0	1	2	3	4	5	6	0	1	2	3	4	5	6	0	1	2	3	4	5	6
RPM	990	945	895	850	800	750	695	1270	1225	1170	1115	1065	1015	965	1090	1030	970	915	860	805	750

Factory sheave settings are shown in bold print.

# INDOOR AIRFLOW PERFORMANCE – RJPL/RJNL-C

## 5 TON

AIR FLOW CFM [L/s]	CAPACITY'S TON - 13 SEER 208-230, 460 - 3 PHASE																											
	EXTERNAL STATIC PRESSURE-INCHES OF WATER																											
	0.1 [.02]	0.2 [.05]	0.3 [.07]	0.4 [.10]	0.5 [.12]	0.6 [.15]	0.7 [.17]	0.8 [.20]	0.9 [.22]	1.0 [.25]	1.10 [.27]	1.20 [.30]	1.30 [.32]	1.40 [.35]	1.50 [.37]													
	RPM	WATTS	RPM	WATTS	RPM	WATTS	RPM	WATTS	RPM	WATTS	RPM	WATTS	RPM	WATTS	RPM	WATTS	RPM	WATTS										
1400 [661]	—	—	780	370	815	385	425	930	460	970	490	1030	540	1065	570	1150	615	1195	645	1235	660	1300	705	1300	705	1340	745	
1500 [708]	—	—	795	405	840	415	895	440	945	500	540	1045	595	1080	615	1165	675	1215	700	1255	735	1320	775	1320	775	1355	805	
1600 [755]	—	780	390	805	870	470	915	510	965	560	600	1060	640	1105	680	1180	730	1225	750	1275	790	1340	840	1340	840	1385	880	
1700 [802]	—	795	450	840	490	530	940	570	990	605	640	1075	660	1120	725	1200	790	1245	815	1300	855	1355	905	1355	905	1375	940	
1800 [850]	780	455	815	470	870	540	915	540	965	605	660	1100	760	1140	785	1175	850	1260	880	1320	930	1365	985	1365	985	1390	1020	
1900 [897]	800	485	850	530	895	590	945	640	995	675	720	1070	775	1120	810	1160	850	1240	890	1290	960	1335	1000	1335	1000	1375	1050	1100
2000 [944]	830	550	880	605	930	655	970	700	1015	730	790	1055	830	1145	875	1180	910	1225	950	1260	980	1320	1035	1320	1035	1370	1120	—
2100 [991]	860	615	915	655	955	705	1005	760	1040	820	870	1130	910	1170	950	1210	995	1250	1020	1290	1060	1335	1100	1370	1150	1400	1200	—
2200 [1038]	895	680	945	735	995	780	1030	830	1060	880	1120	940	1155	1240	1020	1240	1055	1275	1100	1320	1140	1360	1180	1385	1225	—	—	—
2300 [1085]	940	755	975	795	1015	830	1065	910	1100	965	1150	1025	1180	1265	1085	1265	1125	1310	1175	1350	1230	1375	1405	1405	1320	—	—	—
2400 [1133]	970	825	1015	880	1040	925	1100	1005	1145	1055	1175	1085	1225	1140	1260	1175	1300	1210	1340	1255	1370	1400	1375	1400	1200	—	—	—

**NOTE:** L-Drive left of bold line, M-Drive right of bold line.

DRIVE PACKAGE	"L"						"M"							
MOTOR H.P.	3/4						1							
BLOWER SHEAVE	6.4 PITCH DIAMETER						6.4 PITCH DIAMETER							
MOTOR SHEAVE	2.8-3.8 PITCH DIAMETER - ADJ.						3.4-4.4 PITCH DIAMETER - ADJ.							
URNS OPEN	0	1	2	3	4	5	6	0	1	2	3	4	5	6
RPM	1095	1040	<b>995</b>	940	890	835	780	1405	1360	1305	<b>1250</b>	1195	1145	1095

Factory sheave settings are shown in bold.

**AIRFLOW PERFORMANCE — 6 TON [21.1kW] — SIDEFLOW**

**INDOOR AIRFLOW PERFORMANCE – RJNL-C**

Air Flow CFM [L/s]		External Static Pressure — Inches of Water [kPa]																												
		0.1 [0.02]		0.2 [0.05]		0.3 [0.07]		0.4 [0.10]		0.5 [0.12]		0.6 [0.15]		0.7 [0.17]		0.8 [0.20]		0.9 [0.22]		1.0 [0.25]		1.1 [0.27]		1.2 [0.30]		1.3 [0.32]		1.4 [0.35]		1.5 [0.37]
RPM	W	RPM	W	RPM	W	RPM	W	RPM	W	RPM	W	RPM	W	RPM	W	RPM	W	RPM	W	RPM	W	RPM	W	RPM	W	RPM	W	RPM	W	
1900 [897]	—	—	—	847	656	886	687	924	720	962	755	989	793	1036	834	1073	877	1110	923	1146	971	1181	1021	1217	1074	1252	1130	1287	1188	
2000 [944]	—	—	—	872	706	910	740	947	776	984	815	1020	856	1057	900	1092	947	1128	995	1163	1047	1198	1101	1232	1157	1266	1216	1300	1277	
2100 [991]	—	—	—	862	731	899	766	935	803	971	842	1007	885	1043	929	1113	1026	1147	1078	1181	1133	1215	1190	1249	1250	1282	1312	1315	1377	
2200 [1038]	854	762	890	797	926	835	962	876	997	919	1032	964	1066	1012	1101	1062	1135	1115	1168	1171	1201	1229	1234	1289	1352	1299	1418	1331	1486	
2300 [1085]	885	834	920	873	955	914	990	958	1024	1004	1058	1053	1091	1104	1125	1158	1158	1214	1190	1273	1222	1334	1254	1398	1465	1317	1533	1348	1605	
2400 [1133]	917	917	951	959	985	1004	1019	1051	1062	1100	1085	1152	1118	1207	1150	1264	1182	1323	1213	1385	1245	1450	1276	1517	1306	1587	1336	1659	1733	
2500 [1180]	950	1009	983	1055	1016	1103	1049	1153	1081	1206	1113	1261	1145	1319	1176	1379	1207	1442	1238	1508	1288	1575	1298	1646	1328	1719	1357	1794	1886	1872
2600 [1227]	985	1112	1017	1160	1049	1211	1081	1265	1112	1321	1143	1380	1174	1441	1204	1505	1234	1571	1264	1639	1293	1711	1322	1784	1351	1861	1379	1939	1407	2020
2700 [1274]	1020	1224	1052	1276	1083	1330	1114	1387	1144	1446	1174	1508	1204	1573	1233	1640	1262	1709	1291	1781	1319	1856	1347	1933	1375	2012	—	—	—	—
2800 [1321]	1057	1345	1088	1401	1118	1458	1148	1519	1177	1582	1206	1647	1235	1715	1263	1785	1291	1858	1319	1933	1346	2011	—	—	—	—	—	—	—	—
2900 [1368]	1096	1477	1125	1536	1154	1597	1183	1660	1211	1726	1240	1795	1267	1866	1295	1940	1322	2016	—	—	—	—	—	—	—	—	—	—	—	—

NOTE: L-Drive left of bold line. M-Drive right of bold line.

Drive Package	L												M											
Motor H.P. [W]	1.5 [1118.5]												1.5 [1118.5]											
Blower Sheave	AK66												AK66											
Motor Sheave	1VP-44												1VP-50											
Turns Open	0	1	2	3	4	5	6	0	1	2	3	4	5	6	0	1	2	3	4	5	6			
RPM	1103	1052	1002	956	900	849	811	1381	1326	1272	1220	1163	1108	1108	1163	1108	1108	1163	1108	1108	1163	1108		

- 1. Factory sheave settings are shown in bold type.
- 2. Do not set motor sheave below minimum or above maximum turns open shown.
- 3. Re-adjustment of sheave required to achieve rated airflow at ARI minimum External Static Pressure
- 4. Drive data shown is for horizontal airflow with dry coil. Add component resistance (below) to duct resistance to determine total External Static Pressure.

**COMPONENT AIRFLOW RESISTANCE — 6 TON [21.1kW]**

CFM [L/s]	Resistance — Inches of Water [kPa]											
	1900 [897]	2000 [944]	2100 [991]	2200 [1038]	2300 [1085]	2400 [1133]	2500 [1180]	2600 [1227]	2700 [1274]	2800 [1321]	2900 [1368]	
Wet Coil	0.05 [.01]	0.06 [.01]	0.07 [.02]	0.08 [.02]	0.08 [.02]	0.09 [.02]	0.10 [.02]	0.10 [.02]	0.11 [.03]	0.11 [.03]	0.12 [.03]	
Downflow	0.03 [.01]	0.04 [.01]	0.05 [.01]	0.06 [.01]	0.07 [.02]	0.08 [.02]	0.08 [.02]	0.09 [.02]	0.09 [.02]	0.10 [.02]	0.10 [.02]	
Downflow Economizer RA Damper Open	0.08 [.02]	0.08 [.02]	0.09 [.02]	0.09 [.02]	0.10 [.02]	0.10 [.02]	0.11 [.03]	0.11 [.03]	0.11 [.03]	0.12 [.03]	0.12 [.03]	
Horizontal Economizer RA Damper Open	0.08 [.02]	0.08 [.02]	0.09 [.02]	0.09 [.02]	0.10 [.02]	0.10 [.02]	0.11 [.03]	0.11 [.03]	0.11 [.03]	0.12 [.03]	0.12 [.03]	
Concentric Grill RXRN-FA65 or RXRN-FA75 & Transition RXMC-CC04	0.07 [.02]	0.08 [.02]	0.09 [.02]	0.10 [.02]	0.12 [.03]	0.13 [.03]	0.15 [.04]	0.17 [.04]	0.19 [.05]	0.21 [.05]	0.23 [.06]	

[ ] Designates Metric Conversions

# AUXILIARY ELECTRIC HEATER KITS CHARACTERISTICS AND APPLICATION – RJNL-C

<b>208-240 VOLT, THREE PHASE, 60 HZ, AUXILIARY ELECTRIC HEATER KITS CHARACTERISTICS AND APPLICATION</b>												
<b>Separate Power Supply For Both Unit And Heater Kit</b>												
Unit Model Number	<b>Single Power Supply For Both Unit And Heater Kit</b>						<b>Separate Power Supply For Both Unit And Heater Kit</b>					
	<b>Heater Kit</b>			<b>Heat Pump</b>			<b>Heater Kit</b>			<b>Heat Pump</b>		
RXJJ-Heater Kit Nominal kW	No. of Sequence Steps	Rated Heater kW @ 208/240 V	Heater KBTU/Hr @ 208/240 V	Heater Amp. @ 208/240 V	Unit Min. Ckt Ampacity @ 208-240V	Over Current Protective Device Size Min/Max @ 240 V	Min. Ckt. Ampacity 208/240V	Max. Fuse Size 208/240V	Min. Circuit Ampacity 208/240V	Over Current Protective Device Size Min/Max @ 240 V	Min/Max @ 208 V	Min/Max @ 240 V
No Heat	—	—	—	—	18/18	20/25	20/25	—	18/18	20/25	20/25	20/25
A06C	1	4.2/5.6	14.33/19.1	11.7/13.5	33/35	35/35	35/40	15/17	15/20	18/18	20/25	20/25
A10C	1	7.2/9.6	24.56/32.75	20/23.1	43/47	45/45	50/50	25/29	25/30	18/18	20/25	20/25
A12C	1	8.4/11.2	28.66/38.21	23.4/27	48/52	50/50	60/60	30/34	30/35	18/18	20/25	20/25
A15C	1	10.8/14.4	36.84/49.13	30.1/34.7	56/62	60/60	70/70	38/44	40/45	18/18	20/25	20/25
A20C	1	14.4/19.2	49.13/65.5	40/46.3	68/76	70/70	80/80	50/58	50/60	18/18	20/25	20/25
No Heat	—	—	—	—	22/22	25/30	25/30	—	—	22/22	25/30	25/30
A06C	1	4.2/5.6	14.33/19.1	11.7/13.5	37/39	40/45	40/45	15/17	15/20	22/22	25/30	25/30
A10C	1	7.2/9.6	24.56/32.75	20/23.1	47/51	50/50	60/60	25/29	25/30	22/22	25/30	25/30
A12C	1	8.4/11.2	28.66/38.21	23.4/27	52/56	60/60	60/60	30/34	30/35	22/22	25/30	25/30
A15C	1	10.8/14.4	36.84/49.13	30.1/34.7	60/66	60/60	70/70	38/44	40/45	22/22	25/30	25/30
A20C	1	14.4/19.2	49.13/65.5	40/46.3	72/80	80/80	80/80	50/58	50/60	22/22	25/30	25/30
No Heat	—	—	—	—	22/22	25/35	25/35	—	—	22/22	25/35	25/35
A06C	1	4.2/5.6	14.33/19.1	11.7/13.5	37/39	40/45	40/45	15/17	15/20	22/22	25/35	25/35
A10C	1	7.2/9.6	24.56/32.75	20/23.1	47/51	50/50	60/60	25/29	25/30	22/22	25/35	25/35
A12C	1	8.4/11.2	28.66/38.21	23.4/27	52/56	60/60	60/60	30/34	30/35	22/22	25/35	25/35
A15C	1	10.8/14.4	36.84/49.13	30.1/34.7	60/66	60/60	70/70	38/44	40/45	22/22	25/35	25/35
A20C	1	14.4/19.2	49.13/65.5	40/46.3	72/80	80/80	80/80	50/58	50/60	22/22	25/35	25/35
No Heat	—	—	—	—	26/26	30/40	30/40	—	—	26/26	30/40	30/40
A06C	1	4.2/5.6	14.33/19.1	11.7/13.5	41/43	45/50	45/50	15/17	15/20	26/26	30/40	30/40
A10C	1	7.2/9.6	24.56/32.75	20/23.1	51/55	60/60	60/60	25/29	25/30	26/26	30/40	30/40
A12C	1	8.4/11.2	28.66/38.21	23.4/27	56/60	60/50	70/70	30/34	30/35	26/26	30/40	30/40
A15C	1	10.8/14.4	36.84/49.13	30.1/34.7	64/70	70/70	80/80	38/44	40/45	26/26	30/40	30/40
A20C	1	14.4/19.2	49.13/65.5	40/46.3	76/84	80/80	90/90	50/58	50/60	26/26	30/40	30/40
No Heat	—	—	—	—	34/34	40/50	40/50	—	—	34/34	40/50	40/50
A15C	1	10.8/14.4	36.84/49.13	30.1/34.7	72/78	80/80	80/80	38/44	40/45	34/34	40/50	40/50
A20C	1	14.4/19.2	49.13/65.5	40/46.3	84/92	90/90	100/100	50/58	50/60	34/34	40/50	40/50
A24C	1	18/24	61.4/81.88	50/57.7	97/107	100/100	110/110	63/73	70/80	34/34	40/50	40/50

# AUXILIARY ELECTRIC HEATER KITS CHARACTERISTICS AND APPLICATION – RJNL-C

<b>208-240 VOLT, THREE PHASE, 60 HZ, AUXILIARY ELECTRIC HEATER KITS CHARACTERISTICS AND APPLICATION</b>														
<b>Single Power Supply For Both Unit And Heater Kit</b>														
Unit Model Number	Heater Kit							Heat Pump						
	RXJJ-Heater Kit Nominal kW	No. of Sequence Steps	Rated Heater kW @ 208/240 V	Heater KBTU/Hr @ 208/240 V	Heater Amp. @ 208/240 V	Unit Min. Ckt Ampacity @ 208-240V	Over Current Protective Device Size @ 240 V	Heater Kit			Heat Pump			
								Min. Ckt. Ampacity 208/240V	Max. Fuse Size 208/240V	Min. Circuit Ampacity 208/240V	Min/Max @ 208 V	Min/Max @ 240 V	Over Current Protective Device Size	
RJNL-C036CM	No Heat	—	—	—	—	19/19	25/25	19/19	—	—	19/19	25/25	19/19	25/25
	A06C	1	4.2/5.6	14.33/19.1	11.7/13.5	34/36	35/35	15/17	15/20	15/17	15/20	25/25	19/19	25/25
	A10C	1	7.2/9.6	24.56/32.75	20/23.1	44/48	45/45	25/29	25/30	25/29	25/30	25/25	19/19	25/25
	A12C	1	8.4/11.2	28.66/38.21	23.4/27	49/53	50/50	30/34	30/35	30/34	30/35	25/25	19/19	25/25
	A15C	1	10.8/14.4	36.84/49.13	30.1/34.7	57/63	60/60	38/44	40/45	38/44	40/45	25/25	19/19	25/25
	A20C	1	14.4/19.2	49.13/65.5	40/46.3	69/77	70/70	50/58	50/60	50/58	50/60	25/25	19/19	25/25
RJNL-C042CM	No Heat	—	—	—	—	22/22	30/35	—	—	—	—	30/35	22/22	30/35
	A06C	1	4.2/5.6	14.33/19.1	11.7/13.5	37/39	40/45	15/17	15/20	15/17	15/20	30/35	22/22	30/35
	A10C	1	7.2/9.6	24.56/32.75	20/23.1	47/51	50/50	25/29	25/30	25/29	25/30	30/35	22/22	30/35
	A12C	1	8.4/11.2	28.66/38.21	23.4/27	52/56	60/60	30/34	30/35	30/34	30/35	30/35	22/22	30/35
	A15C	1	10.8/14.4	36.84/49.13	30.1/34.7	60/66	70/70	38/44	40/45	38/44	40/45	30/35	22/22	30/35
	A20C	1	14.4/19.2	49.13/65.5	40/46.3	72/80	80/80	50/58	50/60	50/58	50/60	30/35	22/22	30/35
RJNL-C048CM	No Heat	—	—	—	—	23/23	30/35	—	—	—	—	30/35	23/23	30/35
	A06C	1	4.2/5.6	14.33/19.1	11.7/13.5	38/40	40/45	15/17	15/20	15/17	15/20	30/35	23/23	30/35
	A10C	1	7.2/9.6	24.56/32.75	20/23.1	48/52	50/50	25/29	25/30	25/29	25/30	30/35	23/23	30/35
	A12C	1	8.4/11.2	28.66/38.21	23.4/27	53/57	60/60	30/34	30/35	30/34	30/35	30/35	23/23	30/35
	A15C	1	10.8/14.4	36.84/49.13	30.1/34.7	61/67	70/70	38/44	40/45	38/44	40/45	30/35	23/23	30/35
	A20C	1	14.4/19.2	49.13/65.5	40/46.3	73/81	80/80	50/58	50/60	50/58	50/60	30/35	23/23	30/35
RJNL-C060CM	No Heat	—	—	—	—	26/26	30/40	—	—	—	—	30/40	26/26	30/40
	A06C	1	4.2/5.6	14.33/19.1	11.7/13.5	41/43	45/50	15/17	15/20	15/17	15/20	30/40	26/26	30/40
	A10C	1	7.2/9.6	24.56/32.75	20/23.1	51/55	60/60	25/29	25/30	25/29	25/30	30/40	26/26	30/40
	A12C	1	8.4/11.2	28.66/38.21	23.4/27	56/60	60/50	30/34	30/35	30/34	30/35	30/40	26/26	30/40
	A15C	1	10.8/14.4	36.84/49.13	30.1/34.7	64/70	70/70	38/44	40/45	38/44	40/45	30/40	26/26	30/40
	A20C	1	14.4/19.2	49.13/65.5	40/46.3	76/84	80/80	50/58	50/60	50/58	50/60	30/40	26/26	30/40
RJNL-C072CM	No Heat	—	—	—	—	34/34	40/50	—	—	—	—	40/50	34/34	40/50
	A15C	1	10.8/14.4	36.84/49.13	30.1/34.7	72/78	80/80	38/44	40/45	38/44	40/45	40/50	34/34	40/50
	A20C	1	14.4/19.2	49.13/65.5	40/46.3	84/92	90/90	50/58	50/60	50/58	50/60	40/50	34/34	40/50
	A24C	1	18/24	61.41/81.88	50/57.7	97/107	100/100	63/73	70/80	63/73	70/80	40/50	34/34	40/50



# AUXILIARY ELECTRIC HEATER KITS CHARACTERISTICS AND APPLICATION – RJNL-C

<b>480 VOLT, THREE PHASE, 60 HZ, AUXILIARY ELECTRIC HEATER KITS CHARACTERISTICS AND APPLICATION</b>														
<b>Separate Power Supply For Both Unit And Heater Kit</b>														
Unit Model Number	Single Power Supply For Both Unit And Heater Kit							Separate Power Supply For Both Unit And Heater Kit						
	Heater Kit				Heat Pump			Heater Kit				Heat Pump		
	RXJJ-Heater Kit Nominal kW	No. of Sequence Steps	Rated Heater kW @ 480 V	Heater KBTU/Hr @ 480 V	Heater Amp. @ 480 V	Unit Min. Ckt Ampacity @ 480V	Over Current Protective Device Size @ 480 V		Min. Ckt. Ampacity 480V	Max. Fuse Size 480V	Min. Circuit Ampacity 480V	Over Current Protective Device Size @ 480 V		
						Min/Max	Min/Max				Min/Max	Min/Max		
RJNL-C036DL	No Heat													
	A06D	1	5.6	19.1	6.8	10	15/15	10	—	10	15/15	15/15	0/0	
	A10D	1	9.6	32.75	11.6	19	20/20	9	15	10/0	15/15	15/15	0/0	
	A12D	1	11.2	38.21	13.5	25	25/25	—	15	10/0	15/15	15/15	0/0	
	A15D	1	14.4	49.13	17.4	27	30/30	—	17	10/0	15/15	15/15	0/0	
	A20D	1	19.2	65.5	23.3	32	35/35	—	22	10/0	15/15	15/15	0/0	
RJNL-C042DL	No Heat													
	A06D	1	5.6	19.1	6.8	10	15/15	10	—	10	15/15	15/15	0/0	
	A10D	1	9.6	32.75	11.6	19	20/20	9	15	10/0	15/15	15/15	0/0	
	A12D	1	11.2	38.21	13.5	25	25/25	—	15	10/0	15/15	15/15	0/0	
	A15D	1	14.4	49.13	17.4	27	30/30	—	17	10/0	15/15	15/15	0/0	
	A20D	1	19.2	65.5	23.3	32	35/35	—	22	10/0	15/15	15/15	0/0	
RJNL-C048DL	No Heat													
	A06D	1	5.6	19.1	6.8	11	15/15	11	—	11	15/15	15/15	0/0	
	A10D	1	9.6	32.75	11.6	20	20/20	9	15	11/0	15/15	15/15	0/0	
	A12D	1	11.2	38.21	13.5	26	25/25	—	15	11/0	15/15	15/15	0/0	
	A15D	1	14.4	49.13	17.4	28	30/30	—	17	11/0	15/15	15/15	0/0	
	A20D	1	19.2	65.5	23.3	33	35/35	—	22	11/0	15/15	15/15	0/0	
RJNL-C060DL	No Heat													
	A06D	1	5.6	19.1	6.8	13	15/20	13	—	13	15/20	15/20	0/0	
	A10D	1	9.6	32.75	11.6	22	25/25	9	15	13/0	15/20	15/20	0/0	
	A12D	1	11.2	38.21	13.5	28	30/30	—	15	13/0	15/20	15/20	0/0	
	A15D	1	14.4	49.13	17.4	30	30/30	—	17	13/0	15/20	15/20	0/0	
	A20D	1	19.2	65.5	23.3	35	35/35	—	22	13/0	15/20	15/20	0/0	
C072DL	No Heat													
	A06D	1	5.6	19.1	6.8	17	20/25	17	—	17	20/25	20/25	0/0	
	A10D	1	9.6	32.75	11.6	39	40/40	—	25	17/0	20/25	20/25	0/0	
	A12D	1	11.2	38.21	13.5	47	50/50	—	30	17/0	20/25	20/25	0/0	
	A15D	1	14.4	49.13	17.4	54	60/60	—	37	17/0	20/25	20/25	0/0	
	A24D	1	24	81.88	28.9	54	60/60	—	37	17/0	20/25	20/25	0/0	

# AUXILIARY ELECTRIC HEATER KITS CHARACTERISTICS AND APPLICATION – RJNL-C

<b>480 VOLT, THREE PHASE, 60 HZ, AUXILIARY ELECTRIC HEATER KITS CHARACTERISTICS AND APPLICATION</b>													
<b>Separate Power Supply For Both Unit And Heater Kit</b>													
Unit Model Number	Single Power Supply For Both Unit And Heater Kit					Heater Kit				Heat Pump			
	RXJL-Heater Kit Nominal kW	No. of Sequence Steps	Rated Heater kW @ 480 V	Heater KBTU/Hr @ 480 V	Heater Amp. @ 480 V	Unit Min. Ckt Ampacity @ 480V	Over Current Protective Device Size Min/Max @ 480 V	Min. Ckt. Ampacity 480V	Max. Fuse Size 480V	Min. Circuit Ampacity 480V	Over Current Protective Device Size Min/Max @ 480 V	Min/Max @ 480 V	Min/Max @ 480 V
RJNL-C036DM	No Heat	—	—	—	—	10	15/15	—	—	10	15/15	—	—
	A06D	1	5.6	19.1	6.8	19	20/20	—	15	10/0	15/15	0/0	0/0
	A10D	1	9.6	32.75	11.6	25	25/25	—	15	10/0	15/15	0/0	0/0
	A12D	1	11.2	38.21	13.5	27	30/30	—	20	10/0	15/15	0/0	0/0
	A15D	1	14.4	49.13	17.4	32	35/35	—	25	10/0	15/15	0/0	0/0
	A20D	1	19.2	65.5	23.3	40	40/40	—	30	10/0	15/15	0/0	0/0
RJNL-C042DM	No Heat	—	—	—	—	11	15/15	—	—	11	15/15	—	—
	A06D	1	5.6	19.1	6.8	20	20/20	—	15	11/0	15/15	0/0	0/0
	A10D	1	9.6	32.75	11.6	26	30/30	—	15	11/0	15/15	0/0	0/0
	A12D	1	11.2	38.21	13.5	28	30/30	—	20	11/0	15/15	0/0	0/0
	A15D	1	14.4	49.13	17.4	33	35/35	—	25	11/0	15/15	0/0	0/0
	A20D	1	19.2	65.5	23.3	41	40/40	—	30	11/0	15/15	0/0	0/0
RJNL-C048DM	No Heat	—	—	—	—	11	15/15	—	—	11	15/15	—	—
	A06D	1	5.6	19.1	6.8	20	20/20	—	15	11/0	15/15	0/0	0/0
	A10D	1	9.6	32.75	11.6	26	30/30	—	15	11/0	15/15	0/0	0/0
	A12D	1	11.2	38.21	13.5	28	30/30	—	20	11/0	15/15	0/0	0/0
	A15D	1	14.4	49.13	17.4	33	35/35	—	25	11/0	15/15	0/0	0/0
	A20D	1	19.2	65.5	23.3	41	45/45	—	30	11/0	15/15	0/0	0/0
RJNL-C060DM	No Heat	—	—	—	—	14	20/20	—	—	14	20/20	—	—
	A06D	1	5.6	19.1	6.8	23	25/25	—	15	14/0	20/20	0/0	0/0
	A10D	1	9.6	32.75	11.6	29	30/30	—	15	14/0	20/20	0/0	0/0
	A12D	1	11.2	38.21	13.5	31	35/35	—	20	14/0	20/20	0/0	0/0
	A15D	1	14.4	49.13	17.4	36	40/40	—	25	14/0	20/20	0/0	0/0
	A20D	1	19.2	65.5	23.3	44	45/45	—	30	14/0	20/20	0/0	0/0
RJNL-C072DM	No Heat	—	—	—	—	17	20/25	—	—	17	20/25	—	—
	A15D	1	14.4	49.13	17.4	39	40/40	—	25	17/0	20/25	0/0	0/0
	A20D	1	19.2	65.5	23.3	47	50/50	—	30	17/0	20/25	0/0	0/0
	A24D	1	24	81.88	28.9	54	60/60	—	40	17/0	20/25	0/0	0/0

# AUXILIARY ELECTRIC HEATER KITS CHARACTERISTICS AND APPLICATION – RJPL-C

<b>208/240 VOLT, THREE PHASE, 60 HZ, AUXILIARY ELECTRIC HEATER KITS CHARACTERISTICS AND APPLICATION</b>														
<b>Separate Power Supply For Both Unit And Heater Kit</b>														
Unit Model Number	<b>Single Power Supply For Both Unit And Heater Kit</b>							<b>Separate Power Supply For Both Unit And Heater Kit</b>						
	<b>Heater Kit</b>				<b>Heat Pump</b>			<b>Heater Kit</b>				<b>Heat Pump</b>		
RXJJ-Heater Kit Nominal kW	No. of Sequence Steps	Rated Heater kW @ 208/240 V	Heater KBTU/Hr @ 208/240 V	Heater Amp. @ 208/240 V	Unit Min. Ckt Ampacity @ 208/240V	Over Current Protective Device Size		Min. Ckt. Ampacity 208/240V	Max. Fuse Size 208/240V	Min. Circuit Ampacity 208/240V	Over Current Protective Device Size			
						Min/Max @ 208 V	Min/Max @ 240 V				Min/Max @ 280 V	Min/Max @ 240 V		
RJPL-C036CL	No Heat	—	—	—	18/18	20/25	20/25	—	—	18/18	20/25	20/25		
	A06C	4.2/5.6	14.33/19.1	11.7/13.5	33/35	35/35	40/40	15/17	15/20	18/18	20/25	20/25		
	A10C	7.2/9.6	24.56/32.75	20/23.1	43/47	45/45	50/50	25/29	25/30	18/18	20/25	20/25		
	A12C	8.4/11.2	28.66/38.21	23.4/27	48/52	50/50	60/60	30/34	30/35	18/18	20/25	20/25		
	A15C	10.8/14.4	36.84/49.13	30.1/34.7	56/62	60/60	70/70	38/44	40/45	18/18	20/25	20/25		
RJPL-C042CL	No Heat	—	—	—	22/22	25/30	25/30	—	—	22/22	25/30	25/30		
	A06C	4.2/5.6	14.33/19.1	11.7/13.5	37/39	40/45	40/45	15/17	15/20	22/22	25/30	25/30		
	A10C	7.2/9.6	24.56/32.75	20/23.1	47/51	50/50	60/60	25/29	25/30	22/22	25/30	25/30		
	A12C	8.4/11.2	28.66/38.21	23.4/27	52/56	60/60	60/60	30/34	30/35	22/22	25/30	25/30		
	A15C	10.8/14.4	36.84/49.13	30.1/34.7	60/66	60/60	70/70	38/44	40/45	22/22	25/30	25/30		
RJPL-C048CL	No Heat	—	—	—	22/22	25/35	25/35	—	—	22/22	25/35	25/35		
	A06C	4.2/5.6	14.33/19.1	11.7/13.5	37/39	40/45	40/45	15/17	15/20	22/22	25/35	25/35		
	A10C	7.2/9.6	24.56/32.75	20/23.1	47/51	50/50	60/60	25/29	25/30	22/22	25/35	25/35		
	A12C	8.4/11.2	28.66/38.21	23.4/27	52/56	60/60	60/60	30/34	30/35	22/22	25/35	25/35		
	A15C	10.8/14.4	36.84/49.13	30.1/34.7	60/66	70/70	70/70	38/44	40/45	22/22	25/35	25/35		
RJPL-C060CL	No Heat	—	—	—	26/26	30/40	30/40	—	—	26/26	30/40	30/40		
	A06C	4.2/5.6	14.33/19.1	11.7/13.5	41/43	45/50	45/50	15/17	15/20	26/26	30/40	30/40		
	A10C	7.2/9.6	24.56/32.75	20/23.1	51/55	60/60	60/60	25/29	25/30	26/26	30/40	30/40		
	A12C	8.4/11.2	28.66/38.21	23.4/27	56/60	60/60	70/70	30/34	30/35	26/26	30/40	30/40		
	A15C	10.8/14.4	36.84/49.13	30.1/34.7	64/70	70/70	80/80	38/44	40/45	26/26	30/40	30/40		
A20C	14.4/19.2	49.13/65.5	40/46.3	76/84	80/80	90/90	50/58	50/60	26/26	30/40	30/40			

# AUXILIARY ELECTRIC HEATER KITS CHARACTERISTICS AND APPLICATION – RJPL-C

<b>208/240 VOLT, THREE PHASE, 60 HZ, AUXILIARY ELECTRIC HEATER KITS CHARACTERISTICS AND APPLICATION</b>														
<b>Separate Power Supply For Both Unit And Heater Kit</b>														
<b>Single Power Supply For Both Unit And Heater Kit</b>							<b>Separate Power Supply For Both Unit And Heater Kit</b>							
Unit Model Number	<b>Heater Kit</b>				<b>Heat Pump</b>			<b>Heater Kit</b>				<b>Heat Pump</b>		
	RXJL-Heater Kit Nominal kW	No. of Sequence Steps	Rated Heater kW @ 208/240 V	Heater KBTU/Hr @ 208/240 V	Heater Amp. @ 208/240 V	Unit Min. Ckt Ampacity @ 208/240V	Over Current Protective Device Size Min/Max @ 208 V	Min. Ckt Ampacity 208/240V	Max. Fuse Size 208/240V	Min. Circuit Ampacity 208/240V	Over Current Protective Device Size Min/Max @ 280 V	Min/Max @ 240 V	Min/Max @ 240 V	
RJPL-C036CM	No Heat	—	—	—	—	18/18	25/25	—	—	18/18	25/25	25/25		
	A06C	1	4.2/5.6	14.33/19.1	11.7/13.5	33/35	35/35	15/17	15/20	18/18	25/25	25/25		
	A10C	1	7.2/9.6	24.56/32.75	20/23.1	43/47	45/45	25/29	25/30	18/18	25/25	25/25		
	A12C	1	8.4/11.2	28.66/38.21	23.4/27	48/52	50/50	30/34	30/35	18/18	25/25	25/25		
	A15C	1	10.8/14.4	36.84/49.13	30.1/34.7	56/62	60/60	38/44	40/45	18/18	25/25	25/25		
	A20C	1	14.4/19.2	49.13/65.5	40/46.3	68/76	70/70	50/58	50/60	18/18	25/25	25/25		
RJPL-C042CM	No Heat	—	—	—	—	22/22	30/35	—	—	22/22	30/35	30/35		
	A06C	1	4.2/5.6	14.33/19.1	11.7/13.5	37/39	40/45	15/17	15/20	22/22	30/35	30/35		
	A10C	1	7.2/9.6	24.56/32.75	20/23.1	47/51	50/50	25/29	25/30	22/22	30/35	30/35		
	A12C	1	8.4/11.2	28.66/38.21	23.4/27	52/56	60/60	30/34	30/35	22/22	30/35	30/35		
	A15C	1	10.8/14.4	36.84/49.13	30.1/34.7	60/66	60/60	38/44	40/45	22/22	30/35	30/35		
	A20C	1	14.4/19.2	49.13/65.5	40/46.3	72/80	80/80	50/58	50/60	22/22	30/35	30/35		
RJPL-C048CM	No Heat	—	—	—	—	23/23	30/35	—	—	23/23	30/35	30/35		
	A06C	1	4.2/5.6	14.33/19.1	11.7/13.5	38/40	40/45	15/17	15/20	23/23	30/35	30/35		
	A10C	1	7.2/9.6	24.56/32.75	20/23.1	48/52	50/50	25/29	25/30	23/23	30/35	30/35		
	A12C	1	8.4/11.2	28.66/38.21	23.4/27	53/57	60/60	30/34	30/35	23/23	30/35	30/35		
	A15C	1	10.8/14.4	36.84/49.13	30.1/34.7	61/67	70/70	38/44	40/45	23/23	30/35	30/35		
	A20C	1	14.4/19.2	49.13/65.5	40/46.3	73/81	80/80	50/58	50/60	23/23	30/35	30/35		
RJPL-C060CM	No Heat	—	—	—	—	26/26	30/40	—	—	26/26	30/40	30/40		
	A06C	1	4.2/5.6	14.33/19.1	11.7/13.5	41/43	45/50	15/17	15/20	26/26	30/40	30/40		
	A10C	1	7.2/9.6	24.56/32.75	20/23.1	51/55	60/60	25/29	25/30	26/26	30/40	30/40		
	A12C	1	8.4/11.2	28.66/38.21	23.4/27	56/60	60/60	30/34	30/35	26/26	30/40	30/40		
	A15C	1	10.8/14.4	36.84/49.13	30.1/34.7	64/70	70/70	38/44	40/45	26/26	30/40	30/40		
	A20C	1	14.4/19.2	49.13/65.5	40/46.3	76/84	80/80	50/58	50/60	26/26	30/40	30/40		

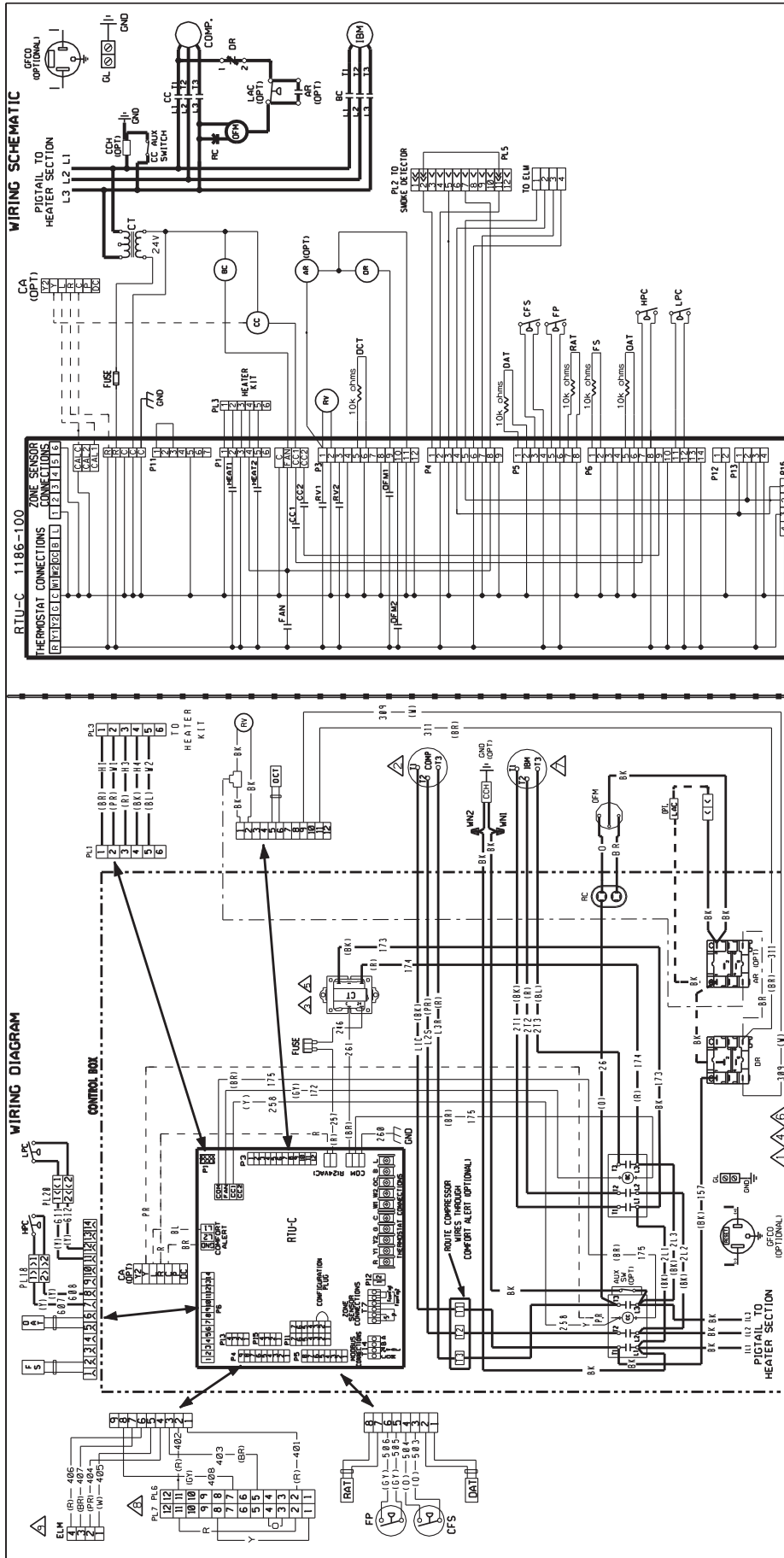
# AUXILIARY ELECTRIC HEATER KITS CHARACTERISTICS AND APPLICATION – RJPL-C

<b>480 VOLT, THREE PHASE, 60 HZ, AUXILIARY ELECTRIC HEATER KITS CHARACTERISTICS AND APPLICATION</b>																
Single Power Supply For Both Unit And Heater Kit						Separate Power Supply For Both Unit And Heater Kit										
Unit Model Number	Heater Kit					Heat Pump					Heater Kit			Heat Pump		
	RXJJ- Heater Kit Nominal kW	No. of Sequence Steps	Rated Heater kW @ 480 V	Heater KBTU/Hr @ 480 V	Heater Amp. @ 480 V	Unit Min. Ckt Ampacity @ 480V	Over Current Protective Device Size		Min. Ckt. Ampacity 480V	Max. Fuse Size 480V	Min. Circuit Ampacity 480V	Over Current Protective Device Size				
							Min/Max @ 480 V	Min/Max @ 480 V				Min/Max @ 480 V	Min/Max @ 480 V			
RJPL-C036DL	No Heat	—	—	—	—	10	15/15	—	—	10	15/15	—	—			
	A06D	1	5.6	19.1	6.8	19	20/20	—	15	10/0	15/15	0/0	0/0			
	A10D	1	9.6	32.75	11.6	25	25/25	—	15	10/0	15/15	0/0	0/0			
	A12D	1	11.2	38.21	13.5	27	30/30	—	20	10/0	15/15	0/0	0/0			
	A15D	1	14.4	49.13	17.4	32	35/35	—	25	10/0	15/15	0/0	0/0			
	A20D	1	19.2	65.5	23.3	40	40/40	—	30	10/0	15/15	0/0	0/0			
RJPL-C042DL	No Heat	—	—	—	—	10	15/15	—	—	10	15/15	—	—			
	A06D	1	5.6	19.1	6.8	19	20/20	—	15	10/0	15/15	0/0	0/0			
	A10D	1	9.6	32.75	11.6	25	25/25	—	15	10/0	15/15	0/0	0/0			
	A12D	1	11.2	38.21	13.5	27	30/30	—	20	10/0	15/15	0/0	0/0			
	A15D	1	14.4	49.13	17.4	32	35/35	—	25	10/0	15/15	0/0	0/0			
	A20D	1	19.2	65.5	23.3	40	40/40	—	30	10/0	15/15	0/0	0/0			
RJPL-C048DL	No Heat	—	—	—	—	11	15/15	—	—	11	15/15	—	—			
	A06D	1	5.6	19.1	6.8	20	20/20	—	15	11/0	15/15	0/0	0/0			
	A10D	1	9.6	32.75	11.6	26	30/30	—	15	11/0	15/15	0/0	0/0			
	A12D	1	11.2	38.21	13.5	28	30/30	—	20	11/0	15/15	0/0	0/0			
	A15D	1	14.4	49.13	17.4	33	35/35	—	25	11/0	15/15	0/0	0/0			
	A20D	1	19.2	65.5	23.3	41	40/40	—	30	11/0	15/15	0/0	0/0			
RJPL-C060DL	No Heat	—	—	—	—	13	15/20	—	—	13	15/20	—	—			
	A06D	1	5.6	19.1	6.8	22	25/25	—	15	13/0	15/20	0/0	0/0			
	A10D	1	9.6	32.75	11.6	28	30/30	—	15	13/0	15/20	0/0	0/0			
	A12D	1	11.2	38.21	13.5	30	30/30	—	20	13/0	15/20	0/0	0/0			
	A15D	1	14.4	49.13	17.4	35	35/35	—	25	13/0	15/20	0/0	0/0			
	A20D	1	19.2	65.5	23.3	43	45/45	—	30	13/0	15/20	0/0	0/0			

# AUXILIARY ELECTRIC HEATER KITS CHARACTERISTICS AND APPLICATION – RJPL-C

<b>480 VOLT, THREE PHASE, 60 HZ, AUXILIARY ELECTRIC HEATER KITS CHARACTERISTICS AND APPLICATION</b>																						
<b>Separate Power Supply For Both Unit And Heater Kit</b>																						
Unit Model Number	<b>Single Power Supply For Both Unit And Heater Kit</b>						<b>Separate Power Supply For Both Unit And Heater Kit</b>															
	<b>Heater Kit</b>			<b>Heat Pump</b>			<b>Heater Kit</b>			<b>Heat Pump</b>												
RXJJ-Heater Kit Nominal kW	No. of Sequence Steps	Rated Heater kW @ 480 V	Heater KBTU/Hr @ 480 V	Heater Amp. @ 480 V	Unit Min. Ckt Ampacity @ 480V	Over Current Protective Device Size Min/Max @ 480 V	Min. Ckt. Ampacity 480V	Max. Fuse Size 480V	Min. Circuit Ampacity 480V	Over Current Protective Device Size Min/Max @ 480 V	RJPL-Model Number	No. of Sequence Steps	Rated Heater kW @ 480 V	Heater KBTU/Hr @ 480 V	Heater Amp. @ 480 V	Unit Min. Ckt Ampacity @ 480V	Over Current Protective Device Size Min/Max @ 480 V	Min. Ckt. Ampacity 480V	Max. Fuse Size 480V	Min. Circuit Ampacity 480V	Over Current Protective Device Size Min/Max @ 480 V	
No Heat	—	—	—	—	10	15/15	—	—	—	10	15/15	—	—	—	—	10	15/15	—	—	—	—	—
A06D	1	5.6	19.1	6.8	19	20/20	—	—	—	9	15/15	—	—	—	9	15	15/15	—	—	—	—	—
A10D	1	9.6	32.75	11.6	25	25/25	—	—	—	15	25/25	—	—	—	15	15	15/15	—	—	—	—	—
A12D	1	11.2	38.21	13.5	27	30/30	—	—	—	17	30/30	—	—	—	17	20	15/15	—	—	—	—	—
A15D	1	14.4	49.13	17.4	32	35/35	—	—	—	22	35/35	—	—	—	22	25	15/15	—	—	—	—	—
A20D	1	19.2	65.5	23.3	40	40/40	—	—	—	30	40/40	—	—	—	30	30	15/15	—	—	—	—	—
No Heat	—	—	—	—	11	15/15	—	—	—	11	15/15	—	—	—	11	—	15/15	—	—	—	—	—
A06D	1	5.6	19.1	6.8	20	20/20	—	—	—	9	20/20	—	—	—	9	15	15/15	—	—	—	—	—
A10D	1	9.6	32.75	11.6	26	30/30	—	—	—	15	30/30	—	—	—	15	15	15/15	—	—	—	—	—
A12D	1	11.2	38.21	13.5	28	30/30	—	—	—	17	30/30	—	—	—	17	20	15/15	—	—	—	—	—
A15D	1	14.4	49.13	17.4	33	35/35	—	—	—	22	35/35	—	—	—	22	25	15/15	—	—	—	—	—
A20D	1	19.2	65.5	23.3	41	40/40	—	—	—	30	40/40	—	—	—	30	30	15/15	—	—	—	—	—
No Heat	—	—	—	—	11	15/15	—	—	—	11	15/15	—	—	—	11	—	15/15	—	—	—	—	—
A06D	1	5.6	19.1	6.8	20	20/20	—	—	—	9	20/20	—	—	—	9	15	15/15	—	—	—	—	—
A10D	1	9.6	32.75	11.6	26	30/30	—	—	—	15	30/30	—	—	—	15	15	15/15	—	—	—	—	—
A12D	1	11.2	38.21	13.5	28	30/30	—	—	—	17	30/30	—	—	—	17	20	15/15	—	—	—	—	—
A15D	1	14.4	49.13	17.4	33	35/35	—	—	—	22	35/35	—	—	—	22	25	15/15	—	—	—	—	—
A20D	1	19.2	65.5	23.3	41	45/45	—	—	—	30	45/45	—	—	—	30	30	15/15	—	—	—	—	—
No Heat	—	—	—	—	13	15/20	—	—	—	13	15/20	—	—	—	13	—	15/20	—	—	—	—	—
A06D	1	5.6	19.1	6.8	22	25/25	—	—	—	9	25/25	—	—	—	9	15	15/20	—	—	—	—	—
A10D	1	9.6	32.75	11.6	28	30/30	—	—	—	15	30/30	—	—	—	15	15	15/20	—	—	—	—	—
A12D	1	11.2	38.21	13.5	30	35/35	—	—	—	17	35/35	—	—	—	17	20	15/20	—	—	—	—	—
A15D	1	14.4	49.13	17.4	35	40/40	—	—	—	22	40/40	—	—	—	22	25	15/20	—	—	—	—	—
A20D	1	19.2	65.5	23.3	43	45/45	—	—	—	30	45/45	—	—	—	30	30	15/20	—	—	—	—	—

**FIGURE 15**  
**WIRING DIAGRAM**



**WIRE COLOR CODE**

BK	BLACK	GY	GRAY	R	RED
BR	BROWN	O	ORANGE	W	WHITE
BL	BLUE	PK	PINK	Y	YELLOW
G	GREEN	PR	PURPLE		

**WIRING INFORMATION**

LINE VOLTAGE

- FACTORY STANDARD
- FACTORY OPTION
- FIELD INSTALLED

LOW VOLTAGE

- FACTORY STANDARD
- FACTORY OPTION
- FIELD INSTALLED

REPLACEMENT WIRE

- MUST BE THE SAME SIZE AND TYPE OF INSULATION AS ORIGINAL (105 C MIN.)
- CABINET MUST BE PERMANENTLY GROUNDED AND CONFORM TO I.E.C., N.E.C., C.E.C. AND LOCAL CODES AS APPLICABLE.

**NOTES:**

- CONNECTORS SUITABLE FOR USE WITH COPPER CONDUCTORS ONLY.
- COMPRESSOR MOTOR, THERMALLY PROTECTED UNDER PRIMARY SINGLE PHASE CONDITIONS.
- TRANSFORMER FACTORY WIRE FOR CORRECT VOLTAGE - 230 VOLT SHOWN FROM 240 VOLT TAP TO 208 VOLT TAP.
- CONNECT FIELD WIRE TO FACTORY WIRE IN ELECTRICAL HEAT SECTION.
- LOW VOLTAGE CIRCUIT IS N.E.C. CLASS 2 WITH A CLASS 2 TRANSFORMER, 24V, 50/60 HZ SUPPLIED.
- CONNECT FIELD WIRING IN GROUNDED RAIN TIGHT CONDUIT TO FUSED DISCONNECT.
- MOTOR FACTORY WIRE FOR CORRECT VOLTAGE.
- REMOVE R7 FOR SMOKE DETECTOR ACCESSORY PL 6 & P7 LOCATED IN RETURN AIR SECTION.
- ECONOMIZER LOGIC MODULE (ELM)

**COMPONENT CODE**

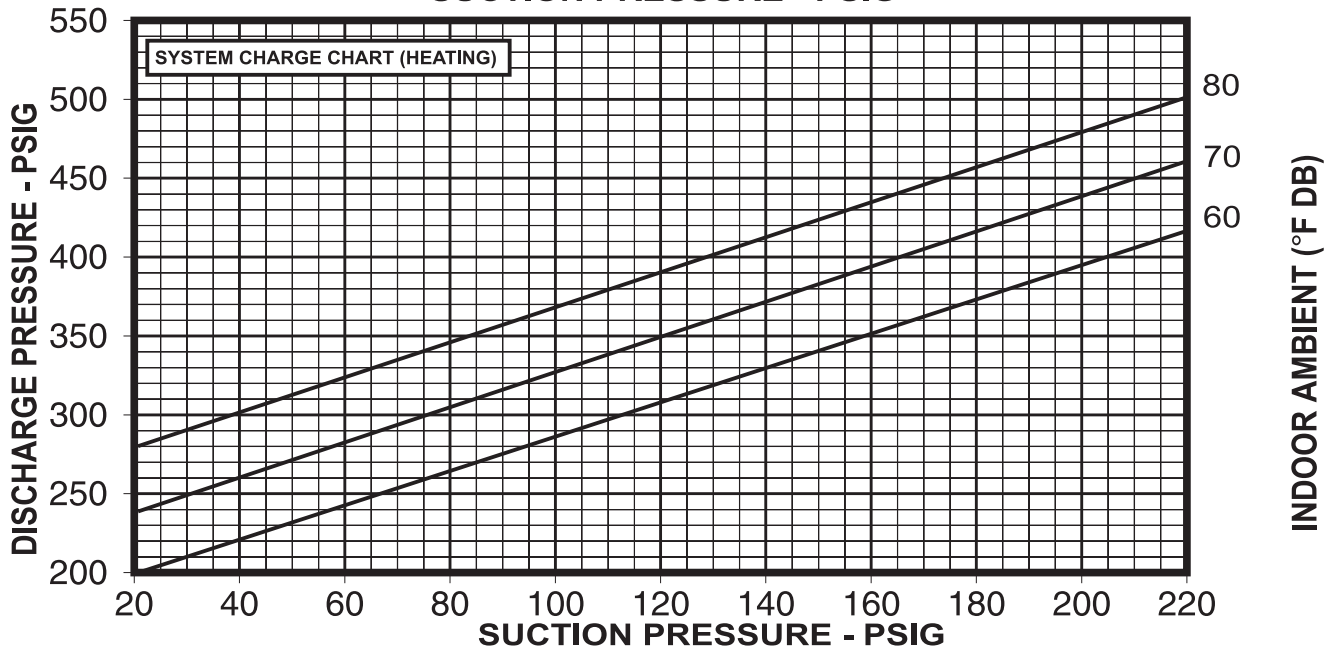
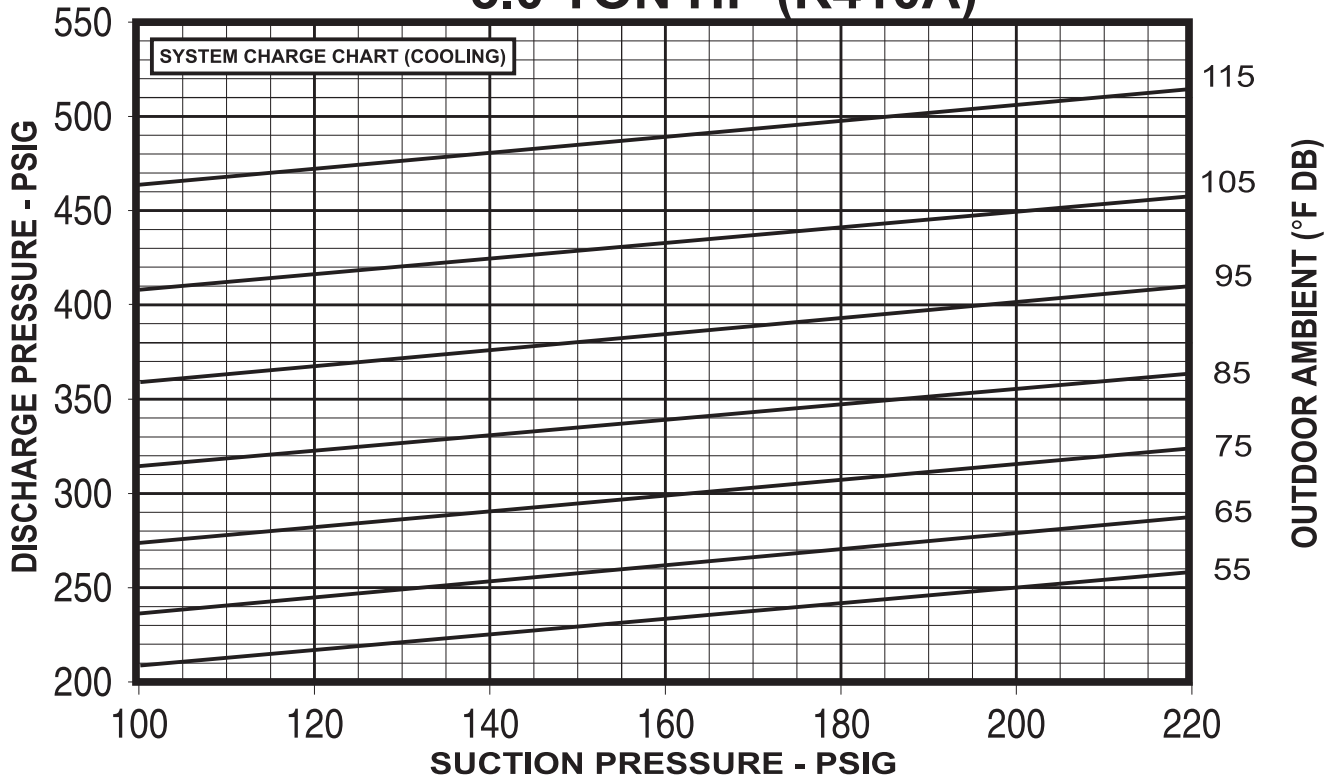
AR	ACCESSORY RELAY	GL	GROUND LUG
BC	BLOWER CONTACTOR	HPC	HIGH PRESSURE CONTROL
CA	COMFORT ALERT MODULE	IBM	INDOOR BLOWER MOTOR BELT DRIVE
CC	COMPRESSOR CONTACTOR	LAC	LOW AMBIENT COOLING CONTROL
CD	CRANKCASE HEATER	LPC	LOW PRESSURE CONTROL
CFS	CLOGGED FILTER SWITCH	DAT	OUTSIDE AIR TEMP SENSOR
COMP	COMPRESSOR	OPM	OUTDOOR FAN MOTOR
CT	CONTROL TRANSFORMER	PL	PLUG
DAT	DISCHARGE AIR SENSOR	PLC	RAIN AIR SENSOR
DR	DRY CONTACT	RC	RAIN PROTECT
ES	FAN PROTECT	RTU-C	ROOF TOP UNIT CONTROL
FS	FREZE SENSOR	RV	REVERSING VALVE
GFCD	GROUND FAULT		WIRE IN/UT
GL	GROUND OUTLET		

**ELECTRICAL WIRING DIAGRAM**  
208-230/460V 3 PH, 60 HZ.  
HEAT PUMP W/RTU-C  
3 - 6 TON

DR. BY: APP. BY: DATE: 7-27-09  
MGR: 90-103232-02  
REV: 02

(13 & 14 SEER)

### 3.0 TON HP (R410A)



**CAUTION:** BEFORE FINAL REFRIGERANT CHECK, INDOOR RETURN AIR TEMPERATURE MUST BE BETWEEN 72°F & 76°F DB AT 50% R.H. (HEATING AND COOLING), AND NO ICE ON OUTDOOR COILS (HEATING).

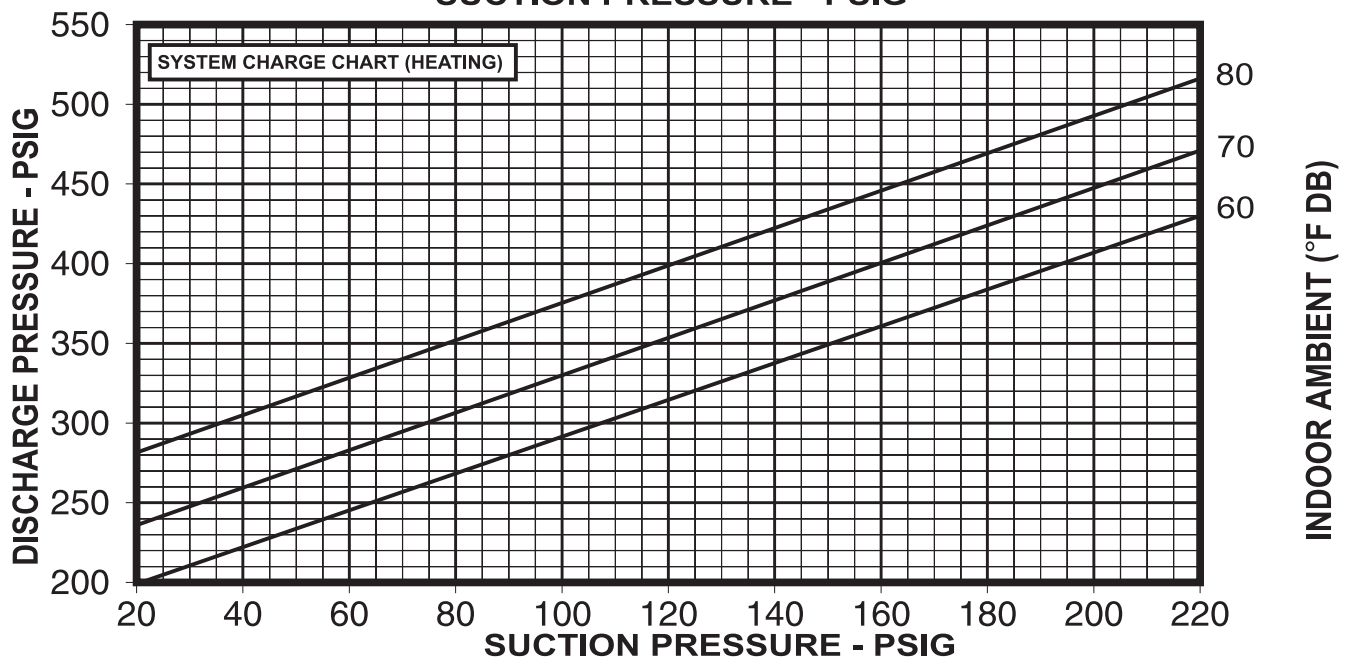
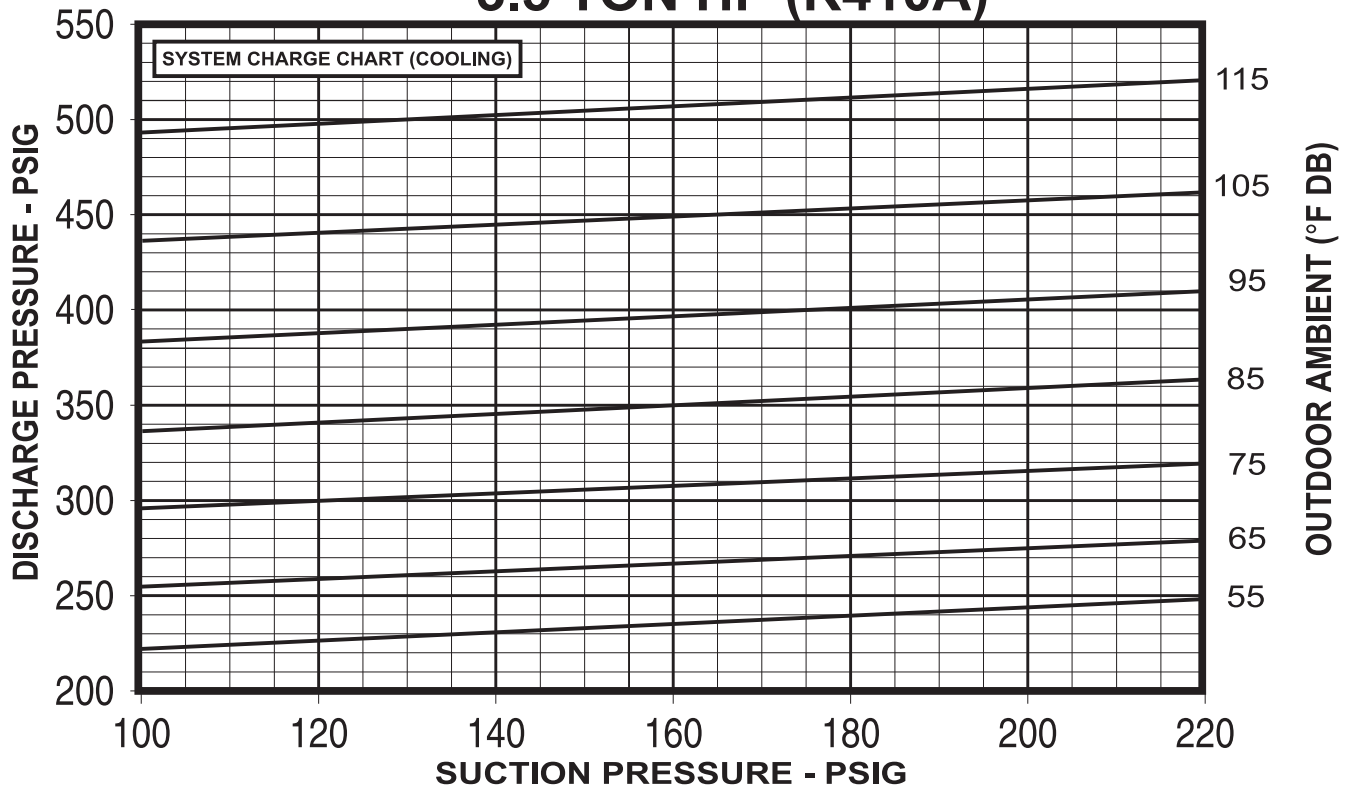
**INSTRUCTIONS:**

1. CONNECT PRESSURE GAUGES TO SUCTION AND DISCHARGE PORTS ON UNIT.
2. MEASURE AIR TEMPERATURE TO: (a) OUTDOOR COIL FOR COOLING, (b) INDOOR COIL FOR HEATING.
3. PLACE AN "X" ON THE APPROPRIATE CHART WHERE THE SUCTION AND DISCHARGE PRESSURES CROSS.
4. IF "X" IS BELOW AMBIENT TEMPERATURE LINE, ADD CHARGE AND REPEAT STEP 3.
5. IF "X" IS ABOVE AMBIENT TEMPERATURE LINE, RECOVER EXCESS CHARGE AND REPEAT STEP 3. 92-102380-01-00



(13 & 14 SEER)

### 3.5 TON HP (R410A)



**CAUTION:** BEFORE FINAL REFRIGERANT CHECK, INDOOR RETURN AIR TEMPERATURE MUST BE BETWEEN 72°F & 76°F DB AT 50% R.H. (HEATING AND COOLING), AND NO ICE ON OUTDOOR COILS (HEATING).

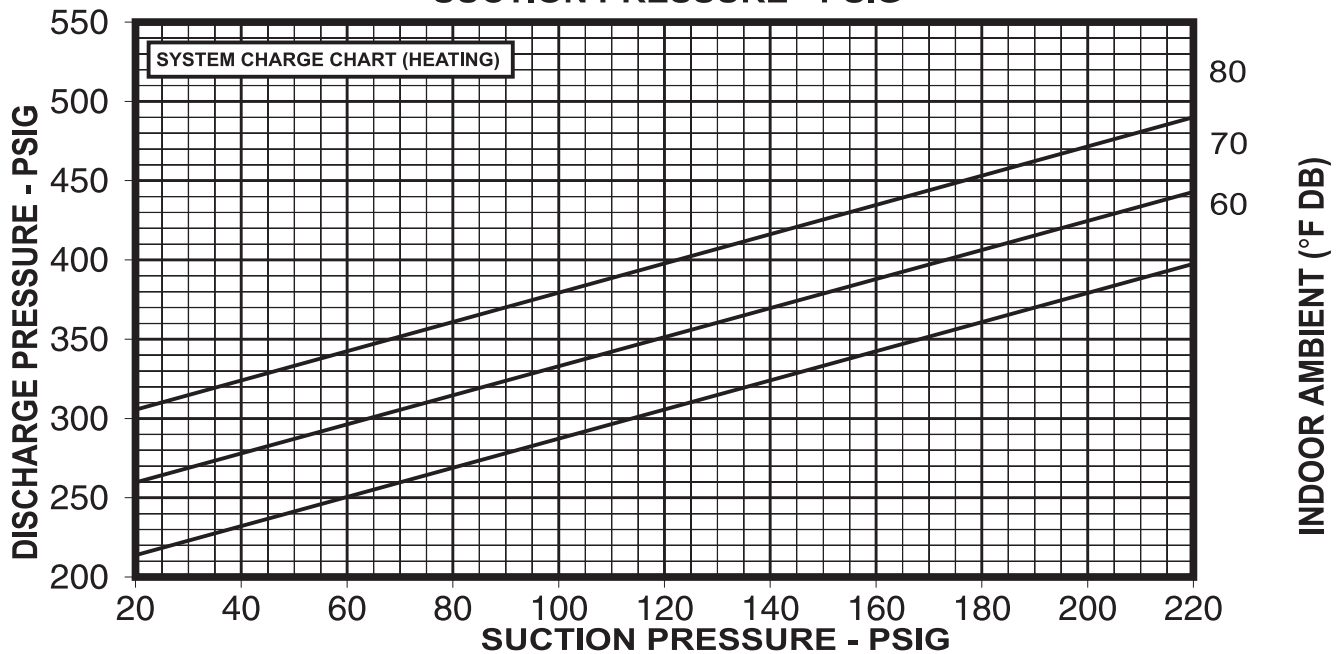
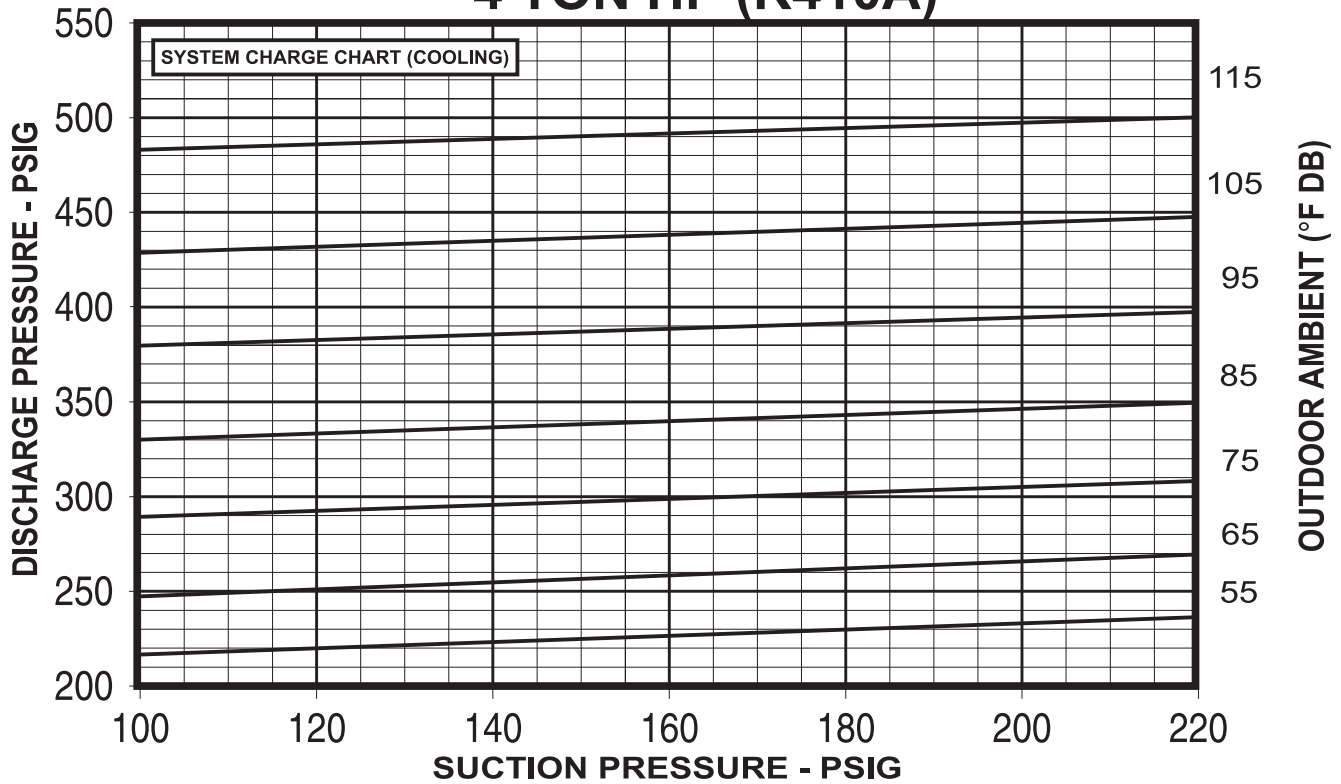
**INSTRUCTIONS:**

1. CONNECT PRESSURE GAUGES TO SUCTION AND DISCHARGE PORTS ON UNIT.
2. MEASURE AIR TEMPERATURE TO: (a) OUTDOOR COIL FOR COOLING, (b) INDOOR COIL FOR HEATING.
3. PLACE AN "X" ON THE APPROPRIATE CHART WHERE THE SUCTION AND DISCHARGE PRESSURES CROSS.
4. IF "X" IS BELOW AMBIENT TEMPERATURE LINE, ADD CHARGE AND REPEAT STEP 3.
5. IF "X" IS ABOVE AMBIENT TEMPERATURE LINE, RECOVER EXCESS CHARGE AND REPEAT STEP 3.

92-102380-02-00

(13 & 14 SEER)

## 4 TON HP (R410A)



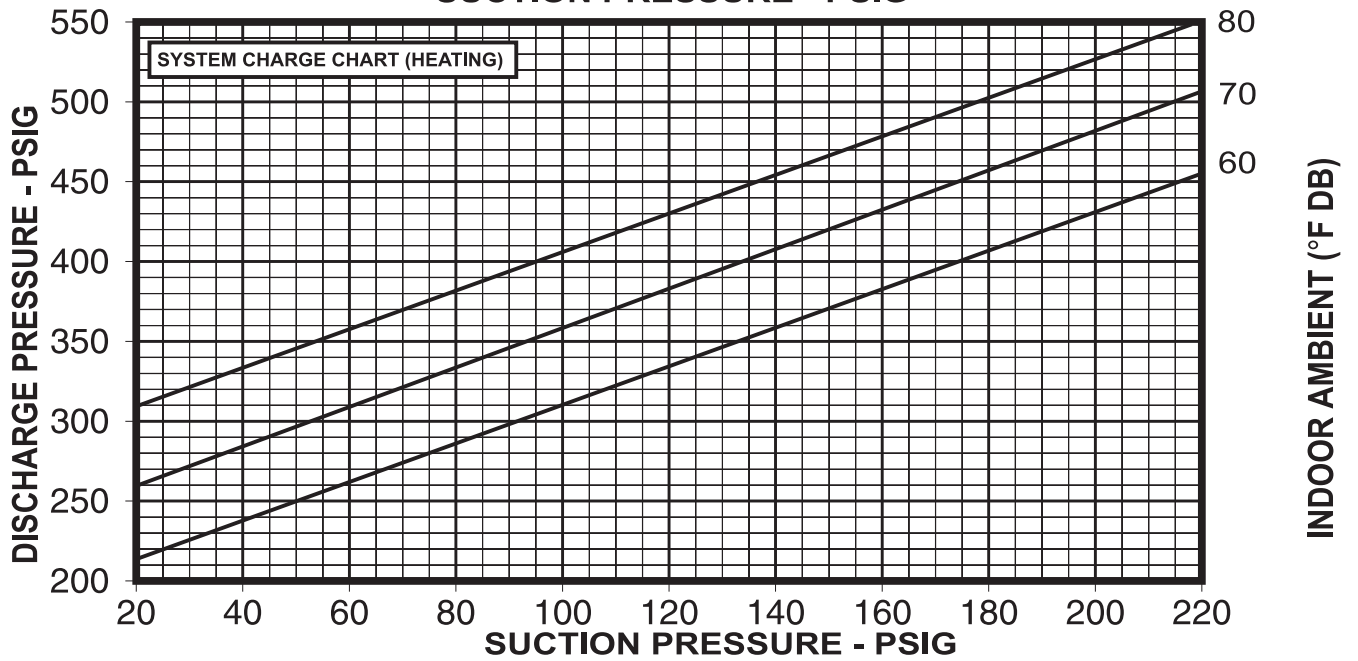
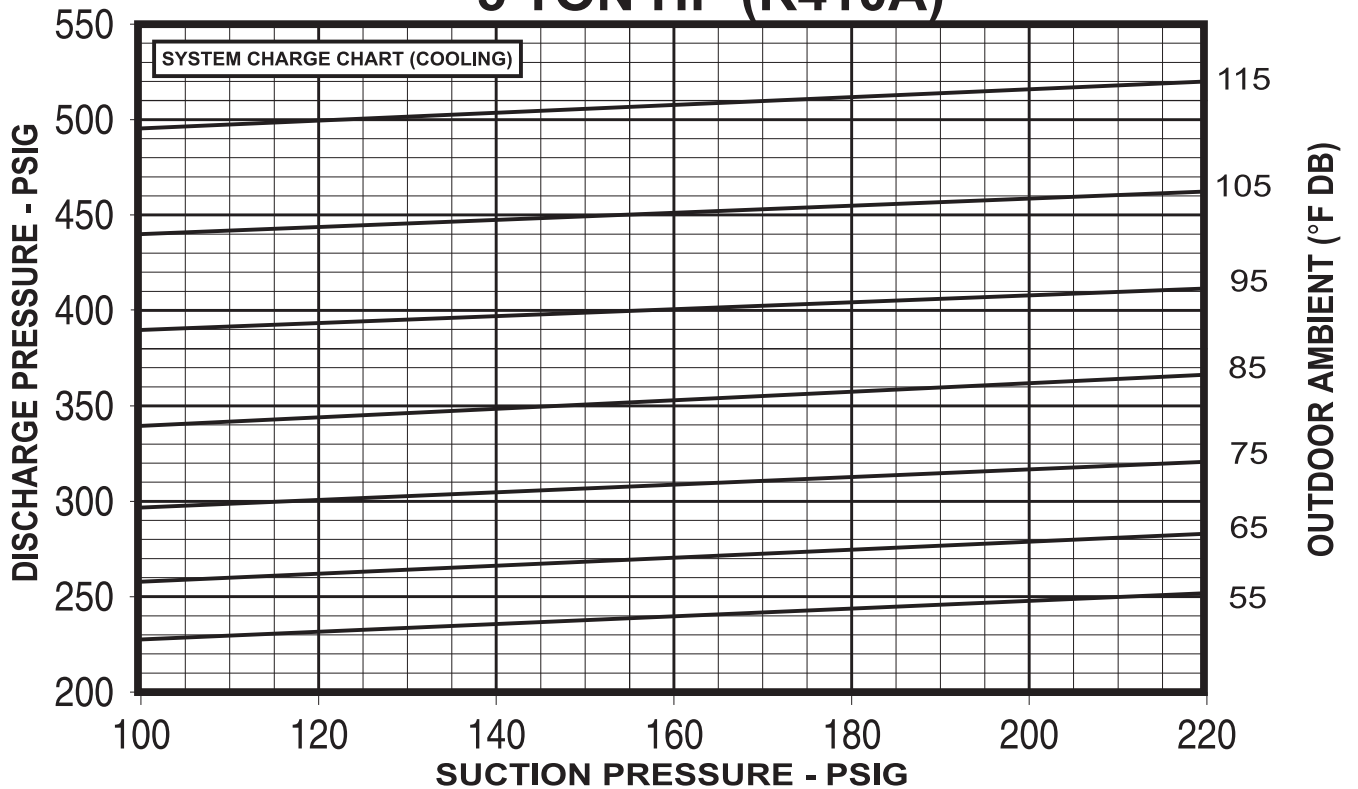
**CAUTION:** BEFORE FINAL REFRIGERANT CHECK, INDOOR RETURN AIR TEMPERATURE MUST BE BETWEEN 72°F & 76°F DB AT 50% R.H. (HEATING AND COOLING), AND NO ICE ON OUTDOOR COILS (HEATING).

**INSTRUCTIONS:**

1. CONNECT PRESSURE GAUGES TO SUCTION AND DISCHARGE PORTS ON UNIT.
2. MEASURE AIR TEMPERATURE TO: (a) OUTDOOR COIL FOR COOLING, (b) INDOOR COIL FOR HEATING.
3. PLACE AN 'X' ON THE APPROPRIATE CHART WHERE THE SUCTION AND DISCHARGE PRESSURES CROSS.
4. IF 'X' IS BELOW AMBIENT TEMPERATURE LINE, ADD CHARGE AND REPEAT STEP 3.
5. IF 'X' IS ABOVE AMBIENT TEMPERATURE LINE, RECOVER EXCESS CHARGE AND REPEAT STEP 3. 92-102380-03-00

# 5 TON – 13 SEER

## 5 TON HP (R410A)



**CAUTION:** BEFORE FINAL REFRIGERANT CHECK, INDOOR RETURN AIR TEMPERATURE MUST BE BETWEEN 72°F & 76°F DB AT 50% R.H. (HEATING AND COOLING), AND NO ICE ON OUTDOOR COILS (HEATING).

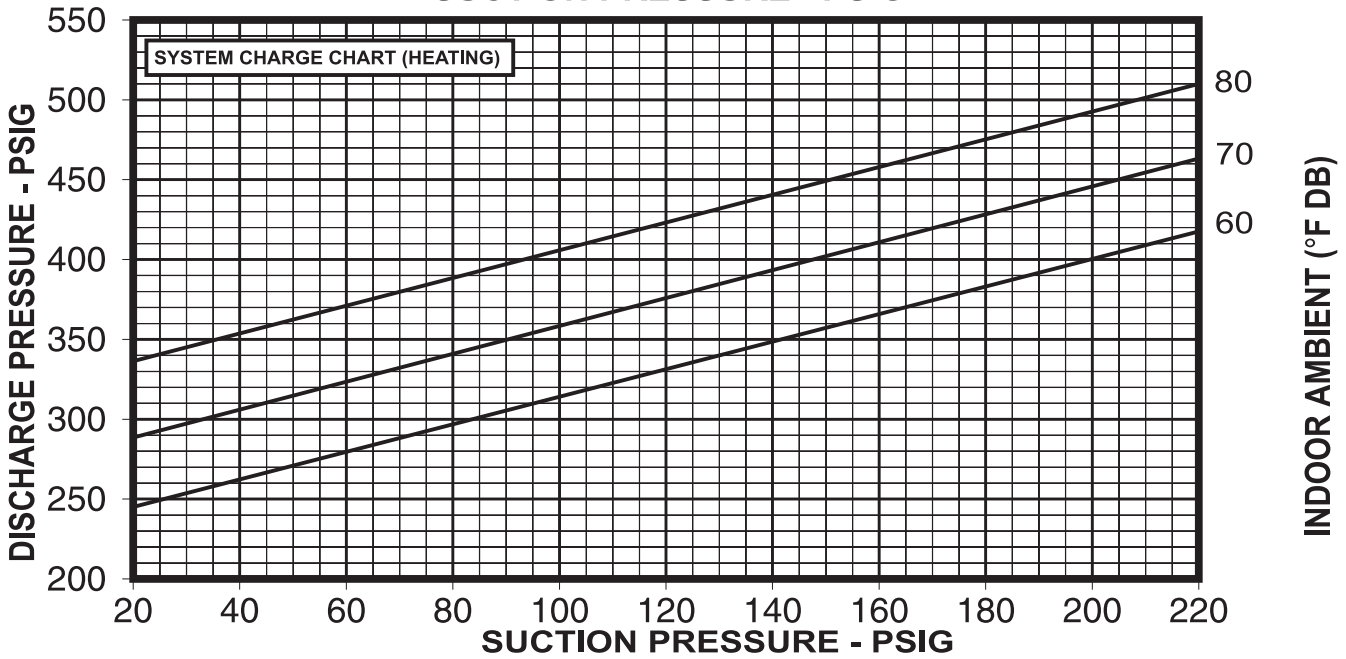
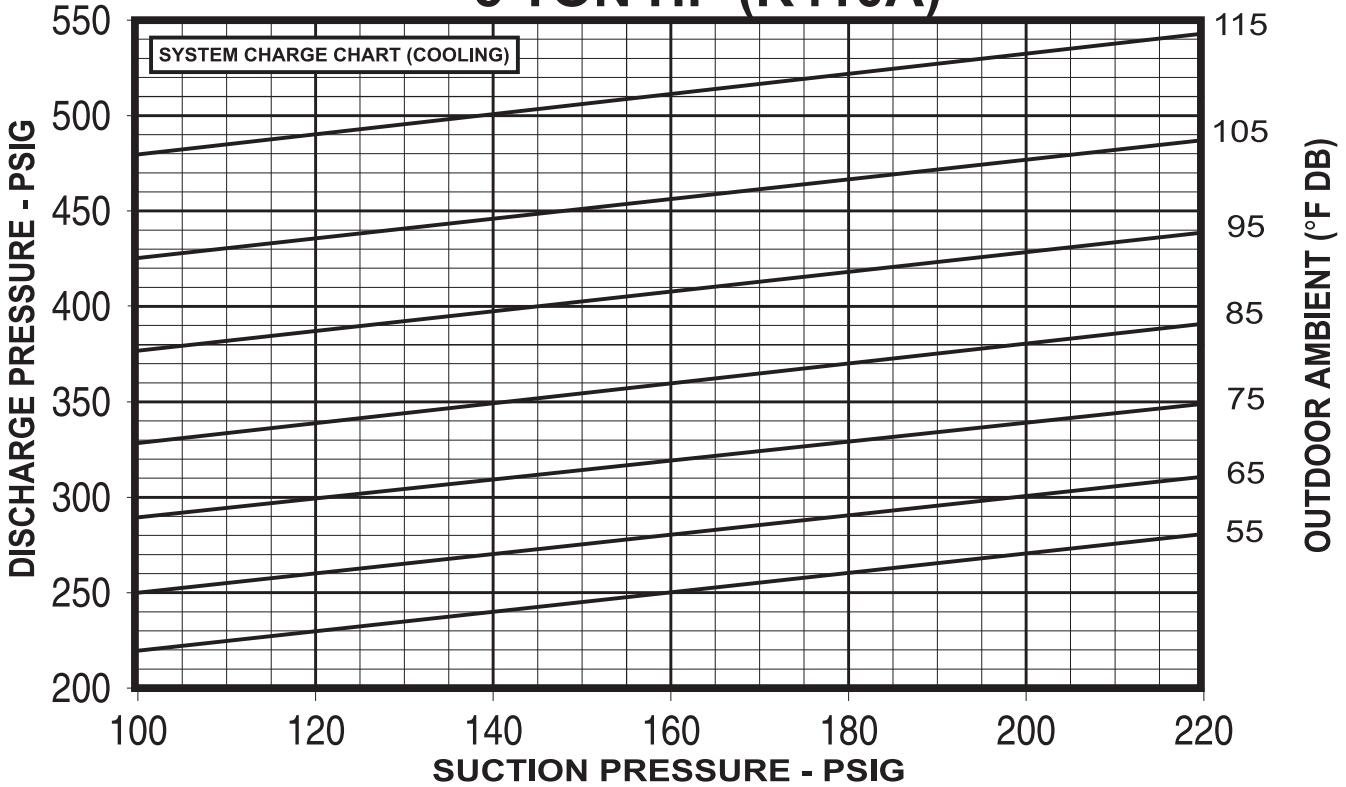
**INSTRUCTIONS:**

1. CONNECT PRESSURE GAUGES TO SUCTION AND DISCHARGE PORTS ON UNIT.
2. MEASURE AIR TEMPERATURE TO: (a) OUTDOOR COIL FOR COOLING, (b) INDOOR COIL FOR HEATING.
3. PLACE AN "X" ON THE APPROPRIATE CHART WHERE THE SUCTION AND DISCHARGE PRESSURES CROSS.
4. IF "X" IS BELOW AMBIENT TEMPERATURE LINE, ADD CHARGE AND REPEAT STEP 3.
5. IF "X" IS ABOVE AMBIENT TEMPERATURE LINE, RECOVER EXCESS CHARGE AND REPEAT STEP 3.

92-102380-04-00

# 5 TON – 14 SEER

## 5 TON HP (R410A)

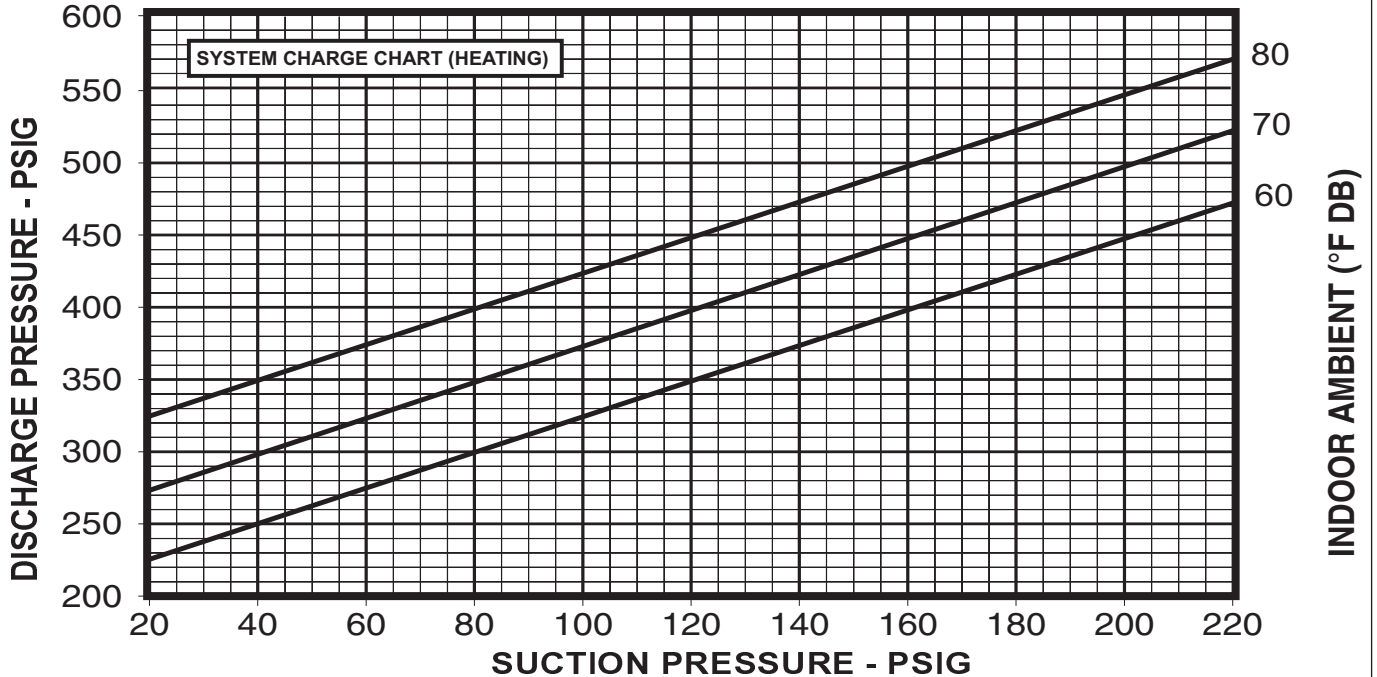
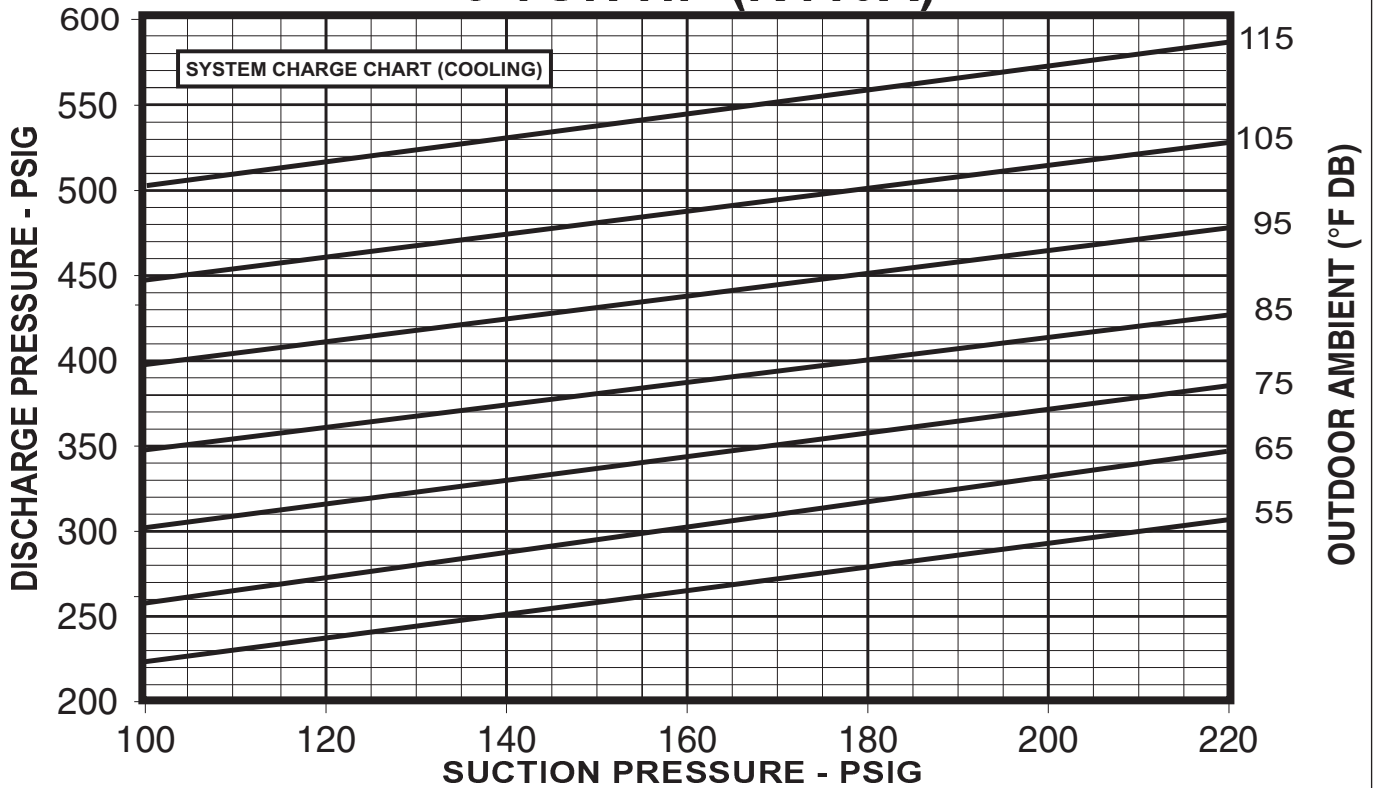


**CAUTION:** BEFORE FINAL REFRIGERANT CHECK, INDOOR RETURN AIR TEMPERATURE MUST BE BETWEEN 72°F & 76°F DB AT 50% R.H. (HEATING AND COOLING), AND NO ICE ON OUTDOOR COILS (HEATING).

**INSTRUCTIONS:**

1. CONNECT PRESSURE GAUGES TO SUCTION AND DISCHARGE PORTS ON UNIT.
2. MEASURE AIR TEMPERATURE TO: (a) OUTDOOR COIL FOR COOLING, (b) INDOOR COIL FOR HEATING.
3. PLACE AN "X" ON THE APPROPRIATE CHART WHERE THE SUCTION AND DISCHARGE PRESSURES CROSS.
4. IF "X" IS BELOW AMBIENT TEMPERATURE LINE, ADD CHARGE AND REPEAT STEP 3.
5. IF "X" IS ABOVE AMBIENT TEMPERATURE LINE, RECOVER EXCESS CHARGE AND REPEAT STEP 3. 92-102380-05-00

# 6 TON HP (R410A)



**CAUTION:** BEFORE FINAL REFRIGERANT CHECK, INDOOR RETURN AIR TEMPERATURE MUST BE BETWEEN 72°F & 76°F DB AT 50% R.H. (HEATING AND COOLING), AND NO ICE ON OUTDOOR COILS (HEATING).

**INSTRUCTIONS:**

1. CONNECT PRESSURE GAUGES TO SUCTION AND DISCHARGE PORTS ON UNIT.
2. MEASURE AIR TEMPERATURE TO: (a) OUTDOOR COIL FOR COOLING, (b) INDOOR COIL FOR HEATING.
3. PLACE AN "X" ON THE APPROPRIATE CHART WHERE THE SUCTION AND DISCHARGE PRESSURES CROSS.
4. IF "X" IS BELOW AMBIENT TEMPERATURE LINE, ADD CHARGE AND REPEAT STEP 3.
5. IF "X" IS ABOVE AMBIENT TEMPERATURE LINE, RECOVER EXCESS CHARGE AND REPEAT STEP 3.

92-102380-06-00

# TROUBLE SHOOTING CHART

**▲ WARNING**

**DISCONNECT ALL POWER TO UNIT BEFORE SERVICING. CONTACTOR MAY BREAK ONLY ONE SIDE. FAILURE TO SHUT OFF POWER CAN CAUSE ELECTRICAL SHOCK RESULTING IN PERSONAL INJURY OR DEATH.**

SYMPTOM	POSSIBLE CAUSE	REMEDY
Unit will not run	<ul style="list-style-type: none"> <li>• Power off or loose electrical connection</li> <li>• Thermostat out of calibration-set too high</li> <li>• Defective contactor</li> <li>• Blown fuses</li> <li>• Transformer defective</li> <li>• High pressure control open (if provided)</li> <li>• Interconnecting low voltage wiring damaged</li> </ul>	<ul style="list-style-type: none"> <li>• Check for correct voltage at compressor contactor in control box</li> <li>• Reset</li> <li>• Check for 24 volts at contactor coil - replace if contacts are open</li> <li>• Replace fuses</li> <li>• Check wiring-replace transformer</li> <li>• Reset-also see high head pressure remedy-</li> <li>• Replace thermostat wiring</li> </ul>
Condenser fan runs, compressor doesn't	<ul style="list-style-type: none"> <li>• Run capacitor defective (single phase only)</li> <li>• Loose connection</li> <li>• Compressor stuck, grounded or open motor winding, open internal overload.</li> <li>• Low voltage condition</li> <li>• Low voltage condition</li> </ul>	<ul style="list-style-type: none"> <li>• Replace</li> <li>• Check for correct voltage at compressor - check &amp; tighten all connections</li> <li>• Wait at least 2 hours for overload to reset. If still open, replace the compressor.</li> <li>• At compressor terminals, voltage must be within 10% of rating</li> <li>• Add start kit components</li> </ul>
Insufficient cooling	<ul style="list-style-type: none"> <li>• Improperly sized unit</li> <li>• Improper airflow</li> <li>• Incorrect refrigerant charge</li> <li>• Air, non-condensibles or moisture in system</li> <li>• Incorrect voltage</li> </ul>	<ul style="list-style-type: none"> <li>• Recalculate load</li> <li>• Check - should be approximately 400 CFM per ton.</li> <li>• Charge per procedure attached to unit service panel</li> <li>• Recover refrigerant, evacuate &amp; recharge, add filter drier</li> <li>• At compressor terminals, voltage must be within 10% of rating plate volts when unit is operating.</li> </ul>
Compressor short cycles	<ul style="list-style-type: none"> <li>• Incorrect voltage</li> <li>• Defective overload protector</li> <li>• Refrigerant undercharge</li> </ul>	<ul style="list-style-type: none"> <li>• At compressor terminals, voltage must be <math>\pm 10\%</math> of nameplate marking when unit is operating.</li> <li>• Replace - check for correct voltage</li> <li>• Add refrigerant</li> </ul>
Registers sweat	<ul style="list-style-type: none"> <li>• Low evaporator airflow</li> </ul>	<ul style="list-style-type: none"> <li>• Increase speed of blower or reduce restriction - replace air filter</li> </ul>
High head-low vapor pressures	<ul style="list-style-type: none"> <li>• Restriction in liquid line, expansion device or filter drier</li> <li>• Flow check piston size too small</li> <li>• Incorrect capillary tubes</li> <li>• TXV does not open</li> </ul>	<ul style="list-style-type: none"> <li>• Remove or replace defective component</li> <li>• Change to correct size piston</li> <li>• Change coil assembly</li> <li>• Replace TXV</li> </ul>
High head-high or normal vapor pressure - Cooling mode	<ul style="list-style-type: none"> <li>• Dirty condenser coil</li> <li>• Refrigerant overcharge</li> <li>• Condenser fan not running</li> <li>• Air or non-condensibles in system</li> </ul>	<ul style="list-style-type: none"> <li>• Clean coil</li> <li>• Correct system charge</li> <li>• Repair or replace</li> <li>• Recover refrigerant, evacuate &amp; recharge</li> </ul>
High head-high or normal vapor pressure - Heating mode	<ul style="list-style-type: none"> <li>• Low air flow - condenser coil</li> <li>• Refrigerant overcharge</li> <li>• Air or non-condensibles in system</li> <li>• Dirty condenser coil</li> </ul>	<ul style="list-style-type: none"> <li>• Check filters - correct to speed</li> <li>• Correct system charge</li> <li>• Recover refrigerant, evacuate &amp; recharge</li> <li>• Check filter - clean coil</li> </ul>
Low head-high vapor pressures	<ul style="list-style-type: none"> <li>• Defective Compressor valves</li> </ul>	<ul style="list-style-type: none"> <li>• Replace compressor</li> </ul>
Low vapor - cool compressor - iced evaporator coil	<ul style="list-style-type: none"> <li>• Low evaporator airflow</li> <li>• Operating below 65°F outdoors</li> <li>• Moisture in system</li> <li>• TXV limiting refrigerant flow</li> </ul>	<ul style="list-style-type: none"> <li>• Increase speed of blower or reduce restriction - replace air filter</li> <li>• Add Low Ambient Kit</li> <li>• Recover refrigerant - evacuate &amp; recharge - add filter drier</li> <li>• Replace TXV</li> </ul>
High vapor pressure	<ul style="list-style-type: none"> <li>• Excessive load</li> <li>• Defective compressor</li> </ul>	<ul style="list-style-type: none"> <li>• Recheck load calculation</li> <li>• Replace</li> </ul>
Fluctuating head & vapor pressures	<ul style="list-style-type: none"> <li>• TXV hunting</li> <li>• Air or non-condensate in system</li> </ul>	<ul style="list-style-type: none"> <li>• Check TXV bulb clamp - check air distribution on coil - replace TXV</li> <li>• Recover refrigerant, evacuate &amp; recharge</li> </ul>
Gurgle or pulsing noise at expansion device or liquid line	<ul style="list-style-type: none"> <li>• Air or non-condensibles in system</li> </ul>	<ul style="list-style-type: none"> <li>• Recover refrigerant, evacuate &amp; recharge</li> </ul>



