

INSTALLATION INSTRUCTIONS

RAWL HIGH EFFICIENCY R-410A COMMERCIAL CONDENSING UNITS NOMINAL SIZES 10, 12.5, 15 & 20 TONS

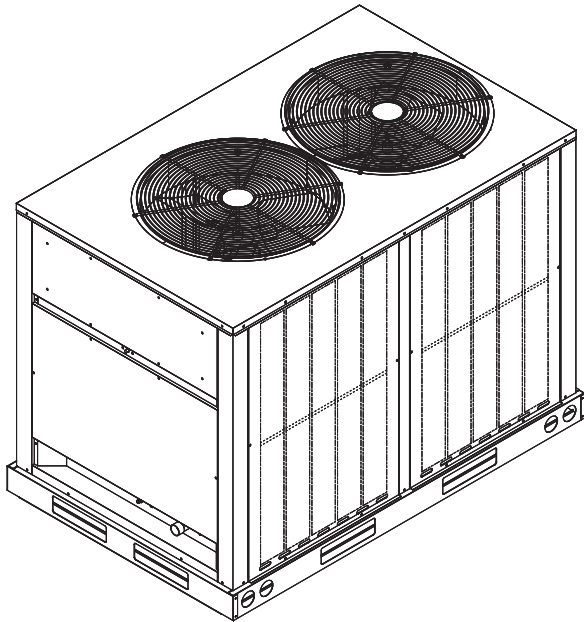

10 & 12.5 TON

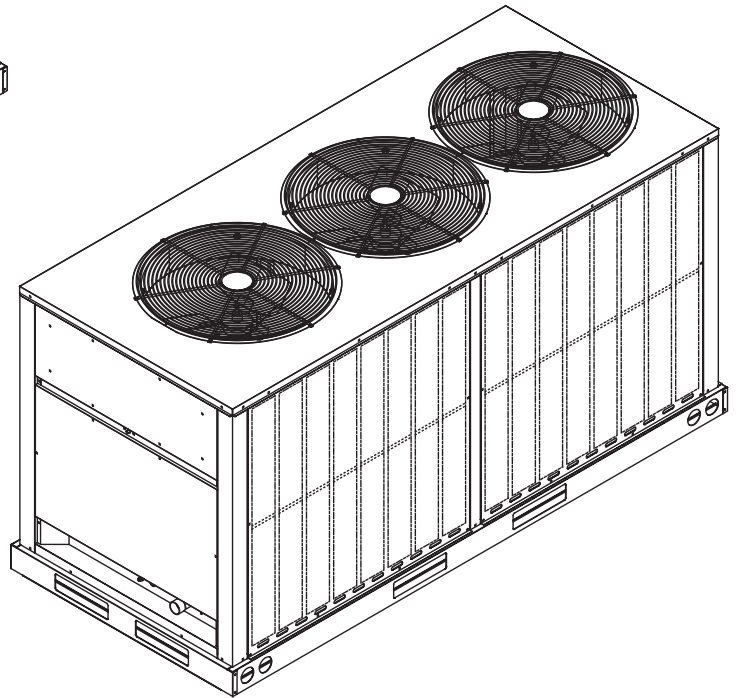

15 & 20 TON



Recognize this symbol as an indication of Important Safety Information!

**DO NOT DESTROY. PLEASE READ CAREFULLY AND
KEEP IN A SAFE PLACE FOR FUTURE REFERENCE.**

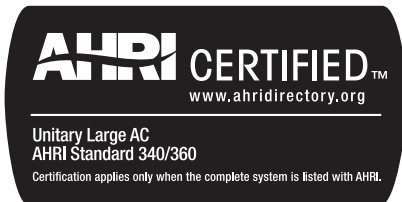

WARNING

THESE INSTRUCTIONS ARE INTENDED AS AN AID TO QUALIFIED, LICENSED SERVICE PERSONNEL FOR PROPER INSTALLATION, ADJUSTMENT AND OPERATION OF THIS UNIT. READ THESE INSTRUCTIONS THOROUGHLY BEFORE ATTEMPTING INSTALLATION OR OPERATION. FAILURE TO FOLLOW THESE INSTRUCTIONS MAY RESULT IN IMPROPER INSTALLATION, ADJUSTMENT, SERVICE OR MAINTENANCE POSSIBLY RESULTING IN FIRE, ELECTRICAL SHOCK, PERSONAL INJURY OR PROPERTY DAMAGE.



TABLE OF CONTENTS

IMPORTANT MESSAGE TO OWNER	4
CHECKING PRODUCT RECEIVED	4
GENERAL	4
STANDARD UNIT FEATURES	4
Physical and Electrical Data	6
Performance Data	6
Unit Dimensions	7-9
INSTALLATION	10
Crankcase Heaters	10
Corrosive Environment	10
Installation General	11
Rooftop Installation	11
Slab Installation	12
INSTALLATION OF PIPING	13
TYPICAL PIPING RECOMMENDATIONS	13-15
ELECTRICAL WIRING	15
Electrical Power	15
Power Wiring	15
Wire Routing	16
Grounding	16
Thermostat	16
TOOLS REQUIRED FOR INSTALLING & SERVICING R-410A MODELS	17
SPECIFICATION OF R-410A	18
QUICK REFERENCE GUIDE FOR R-410A	18
REPLACEMENT UNITS	18
EVAPORATOR COIL	19
LEAK TESTING	19
EVACUATION AND CHARGING	19
FINAL LEAK TESTING	20
PRE-START CHECK	21
MAINTENANCE AND OPERATION	21
Sequence of Operation – RAWL-120	21
Sequence of Operation – RAWL-125, -150, -180, -240, Two Stage	22
Crankcase Heaters	23
Contactors (CC)	23
High Pressure Switch (HPC)	23
Low Pressure Switch (LPC)	23
Low Ambient Control (LAC)	23
Order Parts	23
CHARGING CHARTS	24-28
TROUBLESHOOTING CHART	29
WIRING DIAGRAMS	30-31

IMPORTANT: TO INSURE PROPER INSTALLATION AND OPERATION OF THIS PRODUCT, COMPLETELY READ ALL INSTRUCTIONS PRIOR TO ATTEMPTING TO ASSEMBLE, INSTALL, OPERATE, MAINTAIN OR REPAIR THIS PRODUCT. IMMEDIATELY UPON RECEIPT, ALL CARTONS AND CONTENTS SHOULD BE INSPECTED FOR TRANSIT DAMAGE. UNITS WITH DAMAGED CARTONS SHOULD BE OPENED IMMEDIATELY. IF DAMAGE IS FOUND, IT SHOULD BE NOTED ON THE DELIVERY PAPERS AND A DAMAGE CLAIM FILED WITH THE LAST CARRIER.

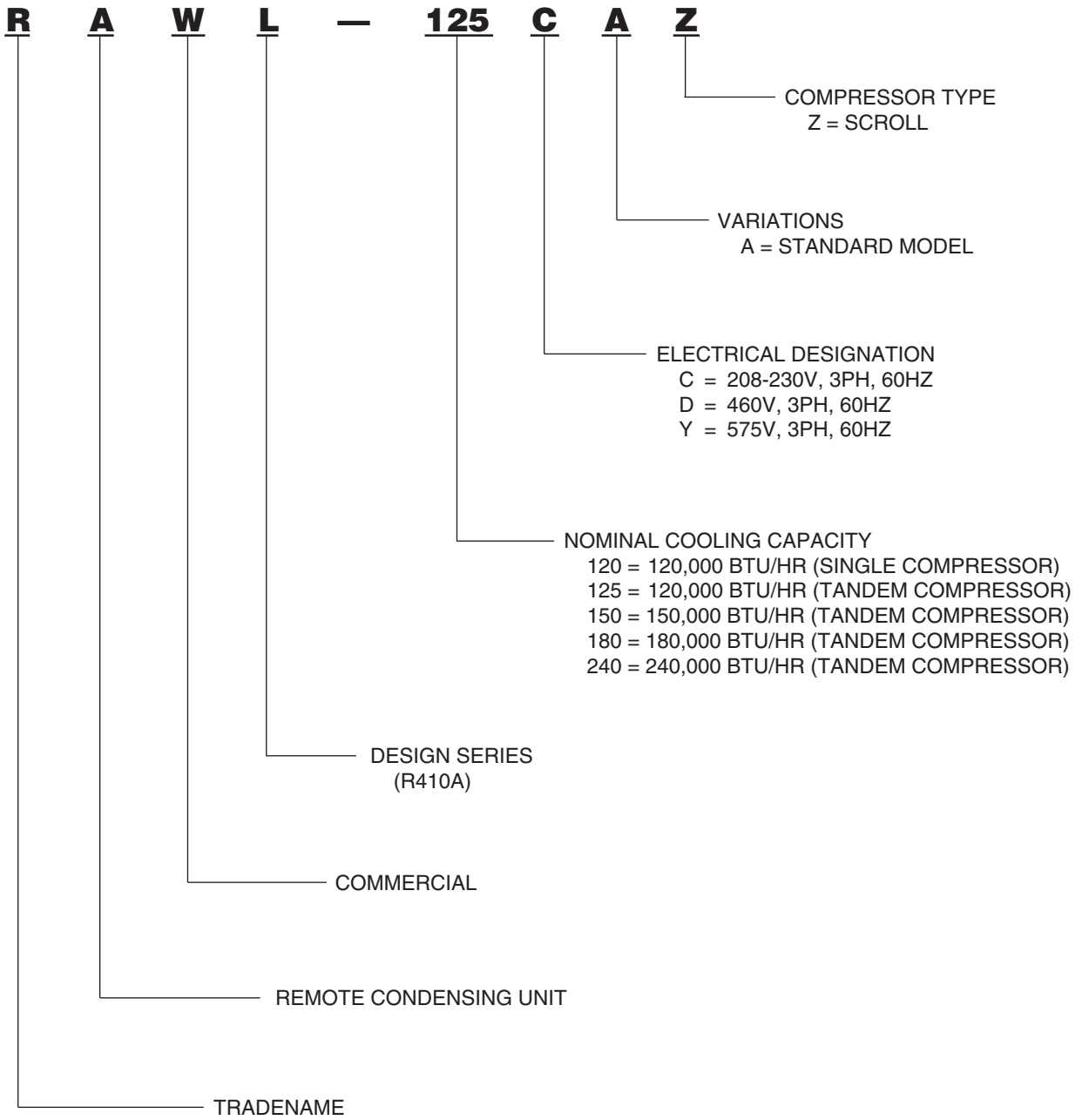

WARNING

THE MANUFACTURER'S WARRANTY DOES NOT COVER ANY DAMAGE OR DEFECT TO THE AIR CONDITIONER CAUSED BY THE ATTACHMENT OR USE OF ANY COMPONENTS, ACCESSORIES OR DEVICES (OTHER THAN THOSE AUTHORIZED BY THE MANUFACTURER) INTO, ONTO OR IN CONJUNCTION WITH THE AIR CONDITIONER, YOU SHOULD BE AWARE THAT THE USE OF UNAUTHORIZED COMPONENTS, ACCESSORIES OR DEVICES MAY ADVERSELY AFFECT THE OPERATION OF THE AIR CONDITIONER AND MAY ALSO ENDANGER LIFE AND PROPERTY. THE MANUFACTURER DISCLAIMS ANY RESPONSIBILITY FOR SUCH LOSS OR INJURY RESULTING FROM THE USE OF SUCH UNAUTHORIZED COMPONENTS, ACCESSORIES OR DEVICES.

IMPORTANT MESSAGE TO OWNER

The manufacturer assumes no responsibility for equipment installed in violation of any code or regulation. The operation portion of this manual gives instructions as to the service and care of the unit. It is recommended that the installer go over the operation portion of this manual with the owner so that there is a full understanding of the equipment and how it is intended to function.

These instructions should be read and kept for future reference. It is suggested that this booklet be affixed to or adjacent to the indoor equipment. It is addressed to your dealer and serviceman, but we highly recommend that you read it—paying particular attention to the section titled “MAINTENANCE.”

CHECKING PRODUCT RECEIVED

Upon receiving unit, inspect it for any shipping damage. Claims for damage, either apparent or concealed, should be filed immediately with the shipping company. Check condensing unit model number, electrical characteristics and accessories to determine if they are correct. Check system components (evaporator coil, condensing unit, evaporator blower, etc.) to make sure they are properly matched.

GENERAL

The information contained in this manual has been prepared to assist in the proper installation, operation and maintenance of the air conditioning system. Improper installation, or installation not made in accordance with these instructions, can result in unsatisfactory operation and/or dangerous conditions, and can cause the related warranty not to apply.

Read this manual and any instructions packaged with separate equipment required to make up the system prior to installation. Retain this manual for future reference.

To achieve unit design operating efficiency and capacity, the indoor cooling coils listed in the condensing unit specification sheet should be used.

STANDARD UNIT FEATURES

CABINET — Galvanized steel with a durable powder paint finish. Stamped louvered panels offer 100% protection for the condenser coil.

COMPRESSOR — The Scroll Compressor is hermetically sealed with internal overload protection and durable insulation on motor windings. The entire compressor is mounted on rubber grommets to reduce vibration and noise.

CONDENSER COIL — Constructed with copper tubes and aluminum fins mechanically bonded to the tubes for maximum heat transfer capabilities.

BASE PAN — Galvanized steel with powder coat paint finish.

REFRIGERANT CONNECTIONS — Field piping connections are made through a fixed panel. This allows complete access or removal of access panels after piping connections have been made.

CRANKCASE HEATER — Standard, all models. Prevents refrigerant migration to compressor(s).

LOW AMBIENT CONTROL — A pressure sensitive fan cycling control to allow unit operation to 0°F is standard.

SERVICE VALVES — Standard on liquid and suction lines. Allows outdoor section to be isolated from indoor coil.

SERVICE ACCESS — Control box as well as the compressor and other refrigerant controls being accessible through access panels.

Control box may be open without affecting the normal operation of the unit.

Condenser fan motors are accessible by removing wire grilles.

FILTER DRIER — Standard (uninstalled) on all models. Helps ensure refrigerant cleanliness.

TRANSFORMER — Step down type, line to 24 volts. Provides control circuit voltage.

CONTACTOR — The contactor is an electrical switch which operates the compressor and condenser fans.

HIGH PRESSURE CONTROL — Opens the contactor circuit on high refrigerant pressure; manual reset.

LOW PRESSURE CONTROL — Stops compressor operation in the event of loss of refrigerant.

CONDENSER FAN MOTOR (Direct Drive) — Ball bearing 1075 RPM motors are mounted to minimize vibration and noise problems. These are permanent split capacitor types.

TESTING — All units are run tested at the factory prior to shipment. Units are shipped with a holding charge of nitrogen.

EXTERNAL GAUGE PORTS — Allows pressures to be checked without removing access panel.

COIL LOUVERS — Helps prevent damage to outdoor coils.

TIME DELAY — Supplied on tandem compressor models to provide a delay between stages.

EQUIPMENT GROUND — Lug for field connecting of ground wire.

FIGURE 1
RAWL-120, RAWL-125, RAWL-150, RAWL-180, RAWL-240 FEATURES

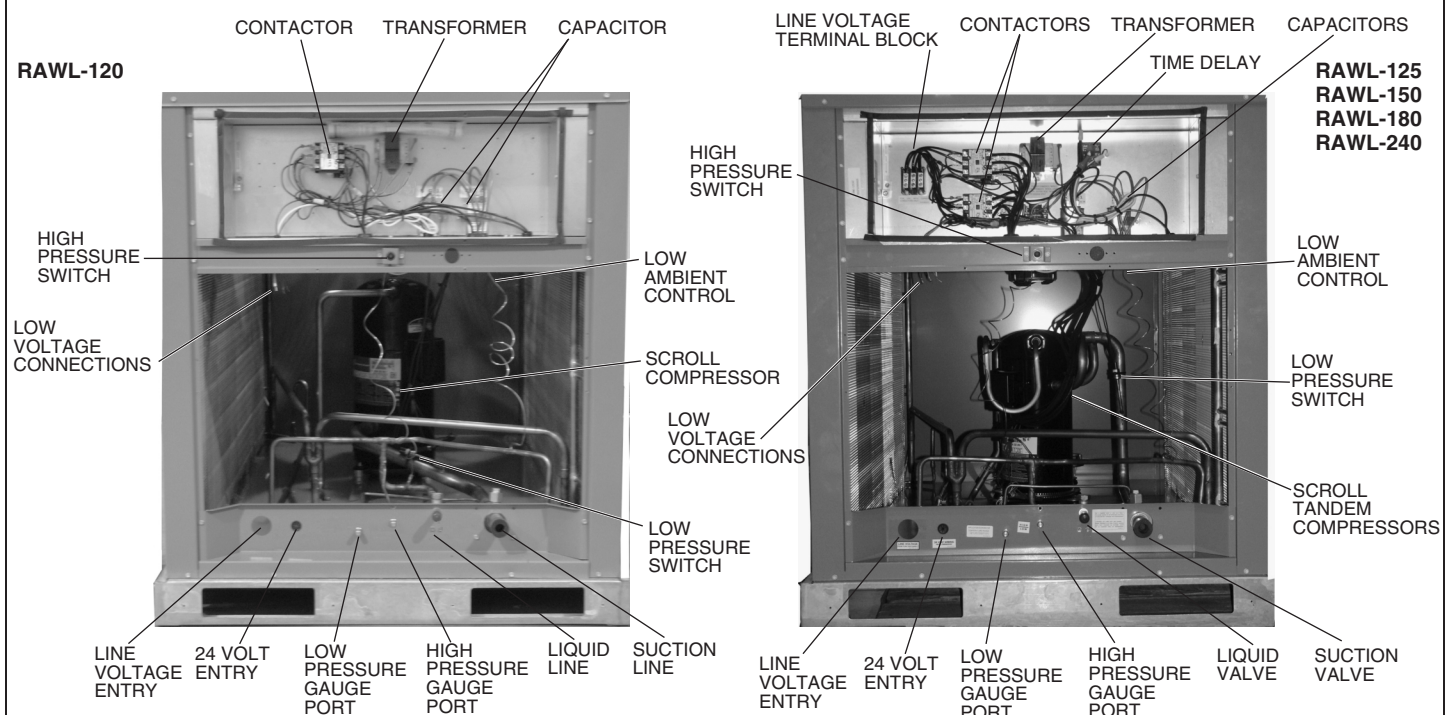

**TABLE 1
ELECTRICAL AND PHYSICAL DATA**

Model Number RAWL-	ELECTRICAL									PHYSICAL					
	Phase Frequency (Hz) Voltage (Volts)	Number of Compressors	Compressor		Number of Fans	Fan Motor Full Load Amperes (FLA) each	Minimum Circuit Ampacity Amperes	Fuse or HACR Circuit Breaker		Outdoor Coil			Refrig. Per Circuit Oz. [g]	Weight	
			Rated Load Amperes (RLA) each	Locked Rotor Amperes (LRA) each				Minimum Amperes	Maximum Amperes	Face Area Sq. Ft. (m ²)	No. Rows	CFM [L/s]		Net Lbs. [kg]	Shipping Lbs. [kg]
Rev. 6/30/2011															
120CAZ	3-60-208/230	1	30.1/30.1	225	2	2.4	43/43	50/50	60/60	27 [2.51]	2	8000 [3775]	339 [9611]	553 [250.8]	593 [250.8]
120DAZ	3-60-460	1	16.7/16.7	114	2	1.4	24	30	40	27 [2.51]	2	8000 [3775]	339 [9611]	553 [250.8]	593 [250.8]
120YAZ	3-60-575	1	12.2	80	2	1	18	25	25	27 [2.51]	2	8000 [3775]	339 [9611]	553 [250.8]	593 [250.8]
125CAZ	3-60-208/230	2*	17.6/17.6	123	2	2.4	45/45	50/50	60/60	27 [2.51]	2	8000 [3775]	300 [8505]	616 [279.4]	656 [279.4]
125DAZ	3-60-460	2*	9.6	62	2	1.4	25	30	30	27 [2.51]	2	8000 [3775]	300 [8505]	616 [279.4]	656 [279.4]
125YAZ	3-60-575	2*	6.1	40	2	1	16	20	20	27 [2.51]	2	8000 [3775]	300 [8505]	616 [279.4]	656 [279.4]
150CAZ	3-60-208/230	2*	22.4/22.4	149	2	2.4	56/56	70/70	70/70	32.88 [3.05]	2	8000 [3775]	378 [10716]	650 [294.8]	690 [294.8]
150DAZ	3-60-460	2*	10.6	75	2	1.4	27	30	35	32.88 [3.05]	2	8000 [3775]	378 [10716]	650 [294.8]	690 [294.8]
150YAZ	3-60-575	2*	7.7	54	2	1	20	25	25	32.88 [3.05]	2	8000 [3775]	378 [10716]	650 [294.8]	690 [294.8]
180CAZ	3-60-208/230	2*	25/25	164	3	2.4	64/64	70/70	80/80	40.38 [3.75]	2	12000[5663]	506 [14345]	746 [338.4]	786 [338.4]
180DAZ	3-60-460	2*	12.2	100	3	1.4	32	35	40	40.38 [3.75]	2	12000[5663]	506 [14345]	746 [338.4]	786 [338.4]
180YAZ	3-60-575	2*	9	78	3	1	24	30	30	40.38 [3.75]	2	12000[5663]	506 [14345]	746 [338.4]	786 [338.4]
240CAZ	3-60-208/230	2*	33.3/33.3	239	3	2.4	83/83	100/100	110/110	40.38 [3.75]	3	12000[5663]	655 [18569]	952 [431.8]	992 [431.8]
240DAZ	3-60-460	2*	17.9	125	3	1.1	44/44	50	60	40.38 [3.75]	3	12000[5663]	655 [18569]	952 [431.8]	992 [431.8]
240YAZ	3-60-575	2*	12.8	80	3	0.8	32	35	40	40.38 [3.75]	3	12000[5663]	655 [18569]	952 [431.8]	992 [431.8]

* - Tandem
[] Designates metric conversions

PERFORMANCE DATA @ AHRI STANDARD CONDITIONS—COOLING: RAWL-

Model Numbers		80°F [26.5°C] DB / 67°F [19.5°C] WB Indoor Air 95°F [35°C] DB Outdoor Air					Sound Rating dB	Indoor CFM [L/s]
Outdoor Unit RAWL-	Indoor Coil and/or Air Handler	Total Capacity BTU/H [kW]	Net Sensible BTU/H [kW]	Net Latent BTU/H [kW]	EER	IEER		
Revised 6/20/2012								
120CAZ	RHGL-120Z ①	117000 [34.3]	86500 [25.3]	30500 [8.9]	11.2	12.2	88	3800 [1793]
	RHGM-120Z	117000 [34.3]	86500 [25.3]	30500 [8.9]	11.2	12.2	88	3800 [1793]
	RCCL-D5013	118000 [34.6]	86500 [25.3]	31500 [9.2]	11.2	12.2	88	3800 [1793]
120DAZ	RHGL-120Z	117000 [34.3]	86500 [25.3]	30500 [8.9]	11.2	12.2	88	3800 [1793]
	RHGM-120Z	117000 [34.3]	86500 [25.3]	30500 [8.9]	11.2	12.2	88	3800 [1793]
	RCCL-D5013	118000 [34.6]	86500 [25.3]	31500 [9.2]	11.2	12.2	88	3800 [1793]
120YAZ	RHGL-120Y	117000 [34.3]	86500 [25.3]	30500 [8.9]	11.2	12.2	88	3800 [1793]
	RCCL-D5013	118000 [34.6]	86500 [25.3]	31500 [9.2]	11.2	12.2	88	3800 [1793]
125CAZ	RHGL-120Z ①	116000 [34.0]	87000 [25.5]	29000 [8.5]	11.2	13.5	88	3800 [1793]
	RHGM-120Z	116000 [34.0]	87000 [25.5]	29000 [8.5]	11.2	13.5	88	3800 [1793]
	RCCL-D5013	116000 [34.0]	85000 [24.9]	31000 [9.1]	11.2	13.5	88	3800 [1793]
125DAZ	RHGL-120Z	116000 [34.0]	87000 [25.5]	29000 [8.5]	11.2	13.5	88	3800 [1793]
	RHGM-120Z	116000 [34.0]	87000 [25.5]	29000 [8.5]	11.2	13.5	88	3800 [1793]
	RCCL-D5013	116000 [34.0]	85000 [24.9]	31000 [9.1]	11.2	13.5	88	3800 [1793]
125YAZ	RHGL-120Y	116000 [34.0]	87000 [25.5]	29000 [8.5]	11.2	13.5	88	3800 [1793]
	RCCL-D5013	116000 [34.0]	85000 [24.9]	31000 [9.1]	11.2	13.5	88	3800 [1793]
150CAZ	RHGL-180Z ①	146000 [42.8]	112000 [32.8]	34000 [10.0]	11.1	14.6	88	5000 [2360]
150DAZ	RHGL-180Z	146000 [42.8]	112000 [32.8]	34000 [10.0]	11.1	14.6	88	5000 [2360]
150YAZ	RHGL-180Y	146000 [42.8]	112000 [32.8]	34000 [10.0]	11.1	14.6	88	5000 [2360]
180CAZ	RHGL-180Z ①	174000 [51.0]	122000 [35.7]	52000 [15.2]	11	13	88	5100 [2407]
180DAZ	RHGL-180Z	174000 [51.0]	122000 [35.7]	52000 [15.2]	11	13	88	5100 [2407]
180YAZ	RHGL-180Y	174000 [51.0]	122000 [35.7]	52000 [15.2]	11	13	88	5100 [2407]
240CAZ	RHGL-240Z ①	244000 [71.5]	169000 [49.5]	75000 [22.0]	10	12.7	88	6900 [3256]
240DAZ	RHGL-240Z	244000 [71.5]	169000 [49.5]	75000 [22.0]	10	12.7	88	6900 [3256]
240YAZ	RHGL-240Y	244000 [71.5]	169000 [49.5]	75000 [22.0]	10	12.7	88	6900 [3256]

① Highest sales volume tested combination required by D.O.E. test procedures.

N/A = Not applicable

[] Designates Metric Conversions

**FIGURE 2
DIMENSIONS — 10 TONS**

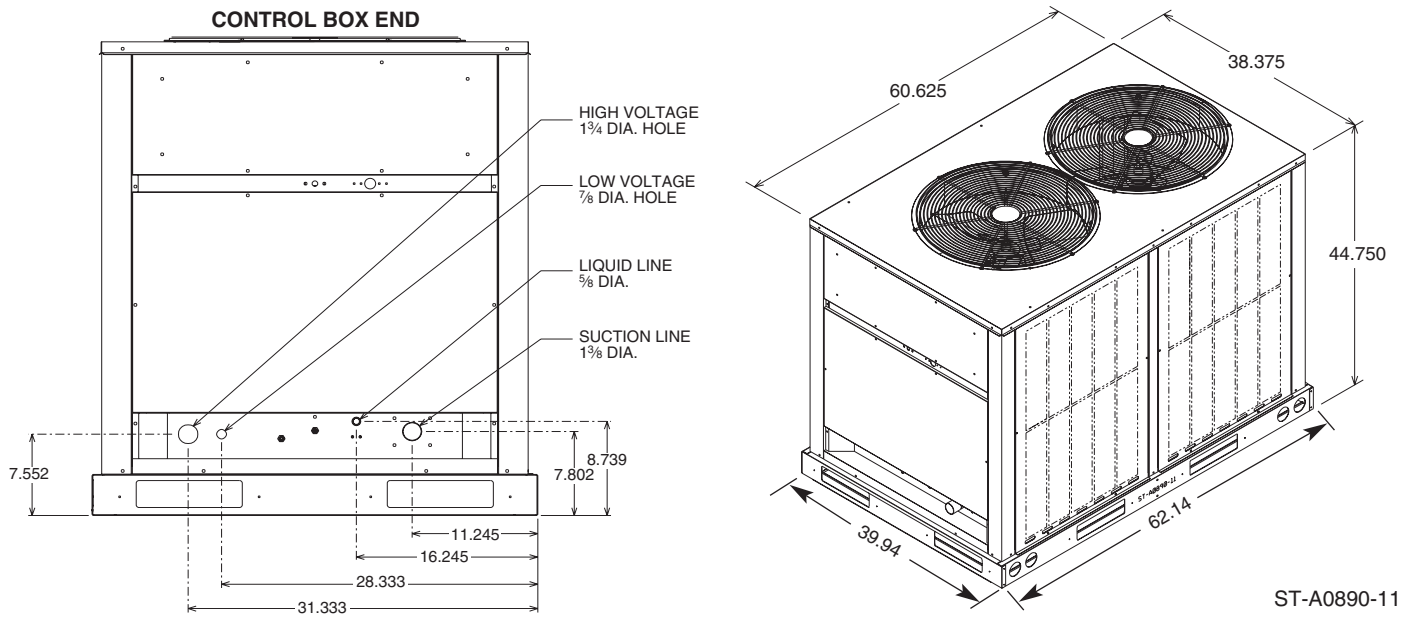

**BOTTOM VIEW
10 TONS**

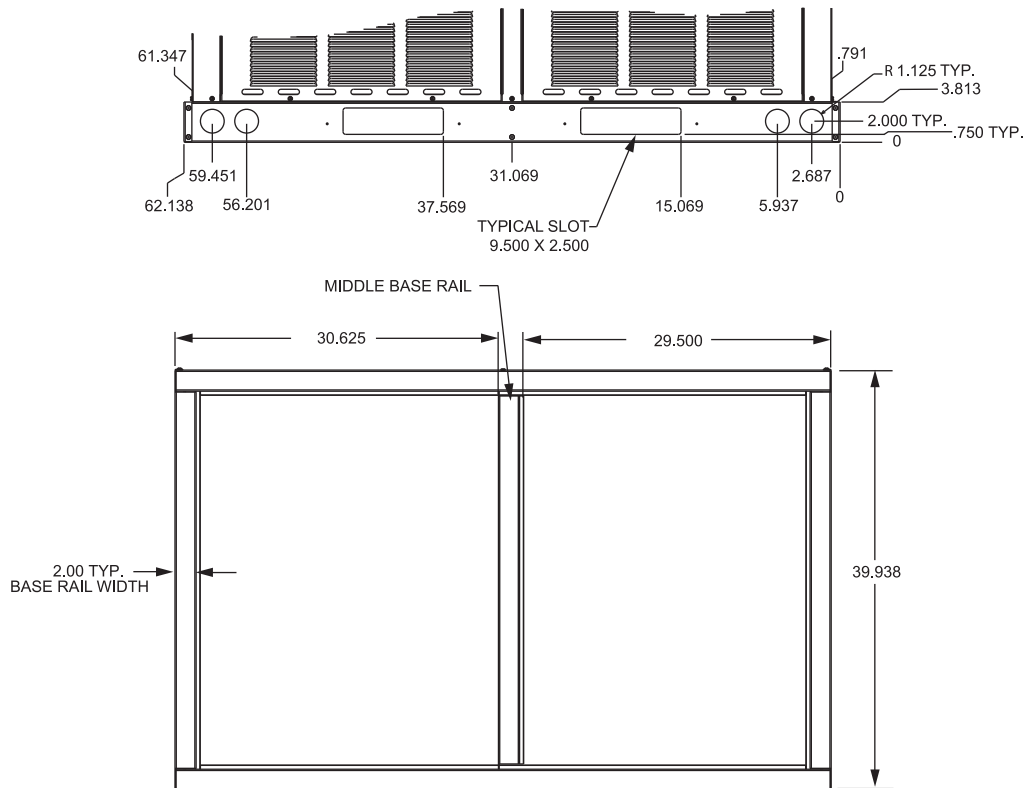

**FIGURE 3
DIMENSIONS — 12.5 TON UNITS**

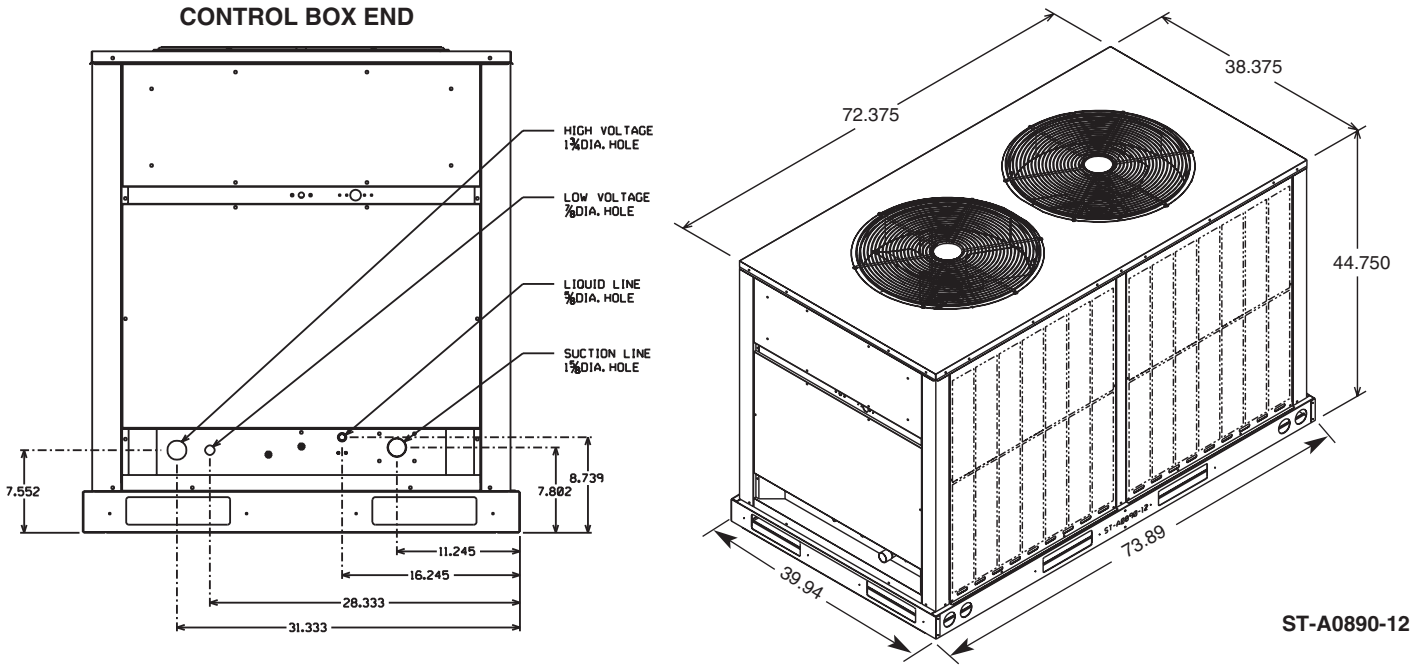

**BOTTOM VIEW
12.5 TONS**

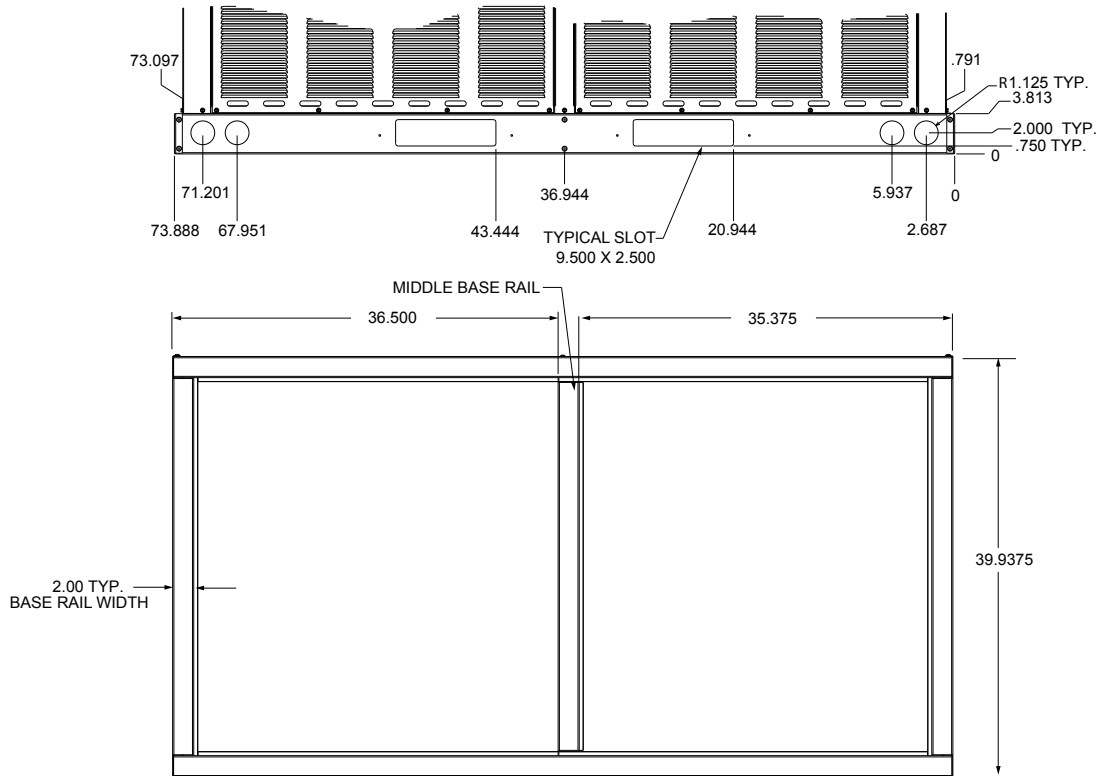
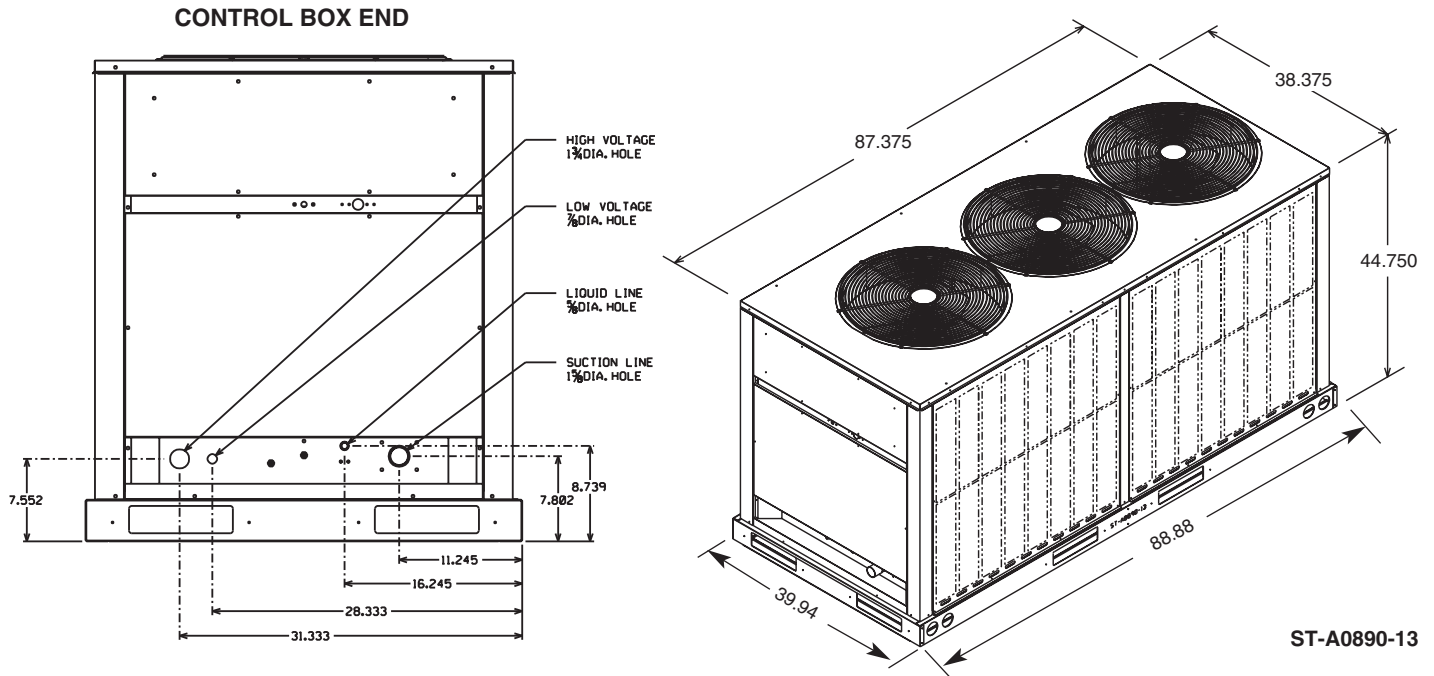
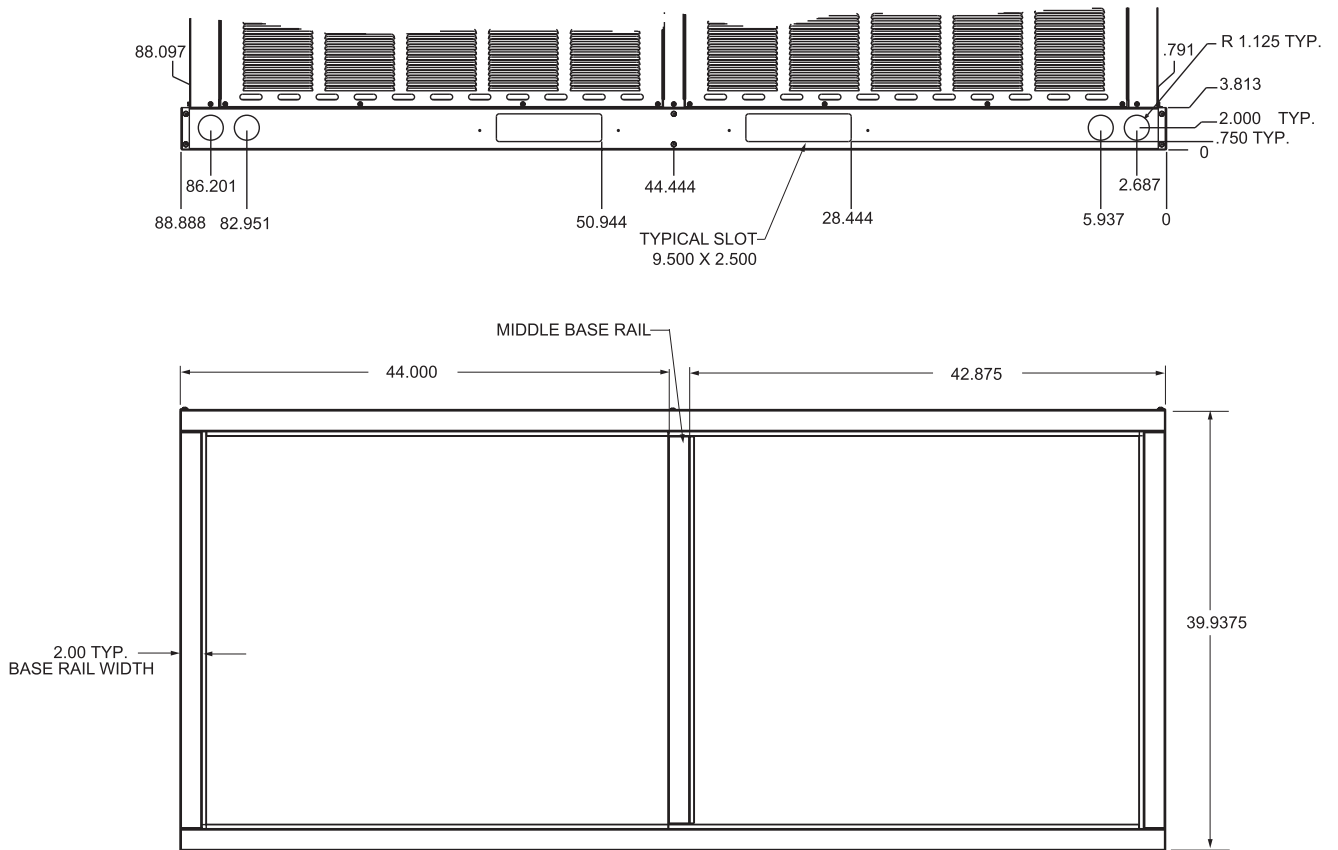

FIGURE 4
DIMENSIONS — 15 TO 20 TON UNITS



BOTTOM VIEW
RAWL-180 & 240



**FIGURE 5
CONTROL BOX CONFIGURATION**

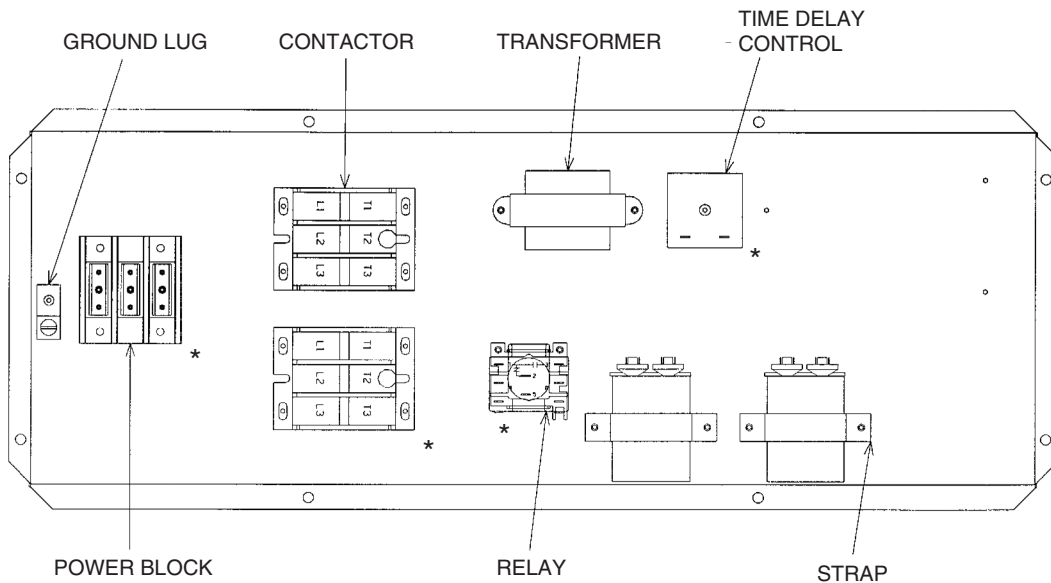

*NOT REQUIRED ON SINGLE COMPRESSOR 10 TON UNIT. (120)

A0890-14

INSTALLATION

CRANKCASE HEATERS

These units are equipped with a crankcase heater. These crankcase heaters are factory wired in such a manner that they are in operation whenever the main power supply to the unit is "on" and compressors are "off." Before starting the equipment after prolonged shut-down or at the time of initial spring start-up, be sure that the circuits to the condensing units are closed for at least 12 hours.

CORROSIVE ENVIRONMENT

The metal parts of this unit may be subject to rust or deterioration if exposed to a corrosive environment. This oxidation could shorten the equipment's useful life. Corrosive elements include salt spray, fog or mist in seacoast areas, sulphur or chlorine from lawn watering systems, and various chemical contaminants from industries such as paper mills and petroleum refineries.

If the unit is to be installed in an area where contaminants are likely to be a problem, special attention should be given to the equipment location and exposure.

- Avoid having lawn sprinkler heads spray directly on the unit cabinet.
- In coastal areas, locate the unit on the side of the building away from the waterfront.
- Shielding provided by a fence or shrubs may give some protection, based on clearances recommended in this book.

Regular maintenance will reduce the build-up of contaminants and help to protect the unit's finish.

⚠ WARNING

DISCONNECT ALL POWER TO UNIT BEFORE STARTING MAINTENANCE. FAILURE TO DO SO CAN CAUSE ELECTRICAL SHOCK RESULTING IN SEVERE PERSONAL INJURY OR DEATH.

- Frequent washing of the cabinet, fan blade and coil with fresh water will remove most of the salt or other contaminants that build up on the unit.
- Regular cleaning and waxing of the cabinet with a good automobile polish will provide some protection.

- A good liquid cleaner may be used several times a year to remove matter that will not wash off with water.

Several different types of protective coatings are offered in some areas. These coatings may provide some benefit, but the effectiveness of such coating materials cannot be verified by the equipment manufacturer.

INSTALLATION GENERAL

The condensing unit should be installed outdoors. It should be located as near as possible to the evaporator section to keep connecting refrigerant tubing lengths to a minimum. The unit must be installed to allow a free air flow to the condenser coils.

If several units are installed adjacent to each other, care must be taken to avoid recirculation of air from one condenser to another. In all installations, the minimum clearances shown in Figure 4 must be provided for installation and servicing.

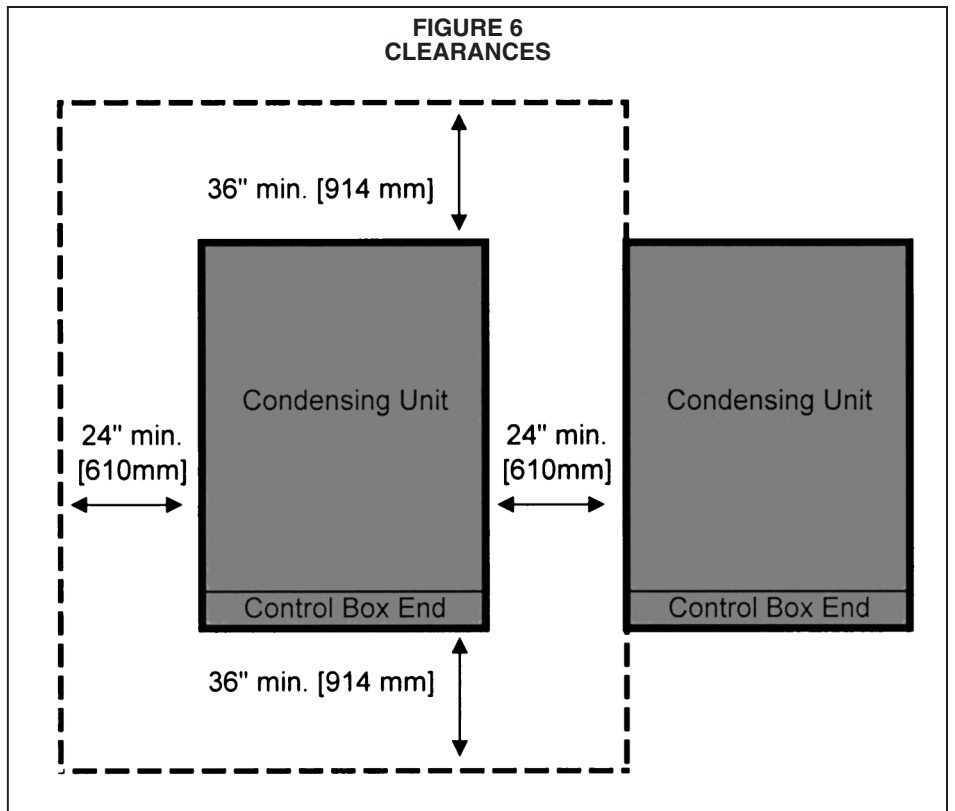

The unit must not be connected to any duct work. Do not locate unit under a roof drip; if necessary, install gutters, etc., to prevent water run-off from hitting the unit. To prevent air recirculation, it is recommended that the unit not be installed under an overhang, but if necessary allow a minimum of 60 inches above the unit for air discharge.

ROOFTOP INSTALLATION

If rooftop installation is required, make certain that the building construction is adequate for the weight of the unit. (Refer to physical data chart.) Before placing the unit on the roof, make certain that the rigging slings are of sufficient length to maintain equilibrium of the unit when lifting. Under no circumstances should the unit be lifted by only one corner for rooftop installation.

SLAB INSTALLATION

Condensing units should be set on a solid level foundation. When installed at ground level, the unit should be placed on a 6 inch cement slab. If the pad is formed at the installation site, do not pour the pad tight against the structure, otherwise vibration will be transmitted from the unit through the pad.

**FIGURE 7
ROOFTOP INSTALLATION – RIGGING**

CORNER WEIGHTS – POUNDS

Model	Total Weight	A	B	C	D
RAWL-120	501 [227]	123 [56]	132 [60]	119 [54]	127 [58]
RAWL-125	586 [266]	144 [65]	154 [70]	139 [63]	149 [67]
RAWL-150	650 [295]	160 [72]	171 [78]	154 [70]	165 [75]
RAWL-180	746 [338]	183 [83]	196 [89]	177 [80]	189 [86]
RAWL-240	952 [432]	234 [106]	251 [114]	226 [103]	241 [110]

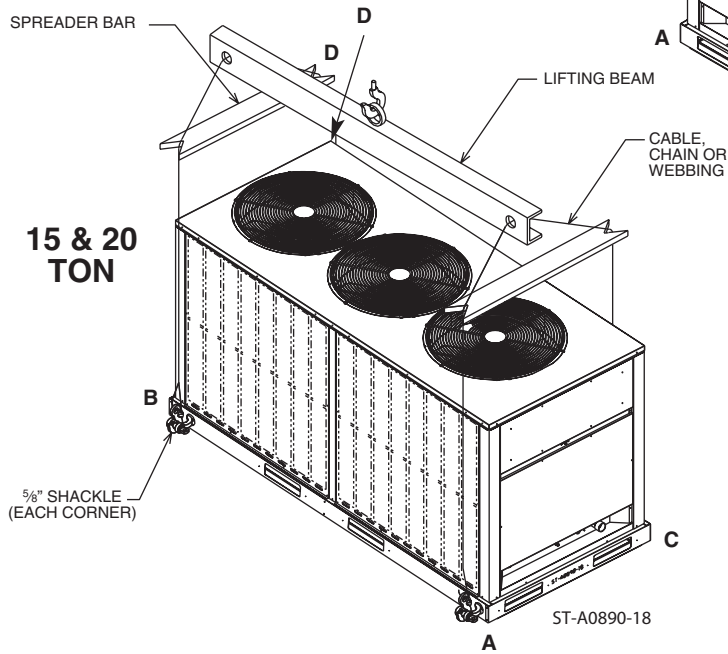
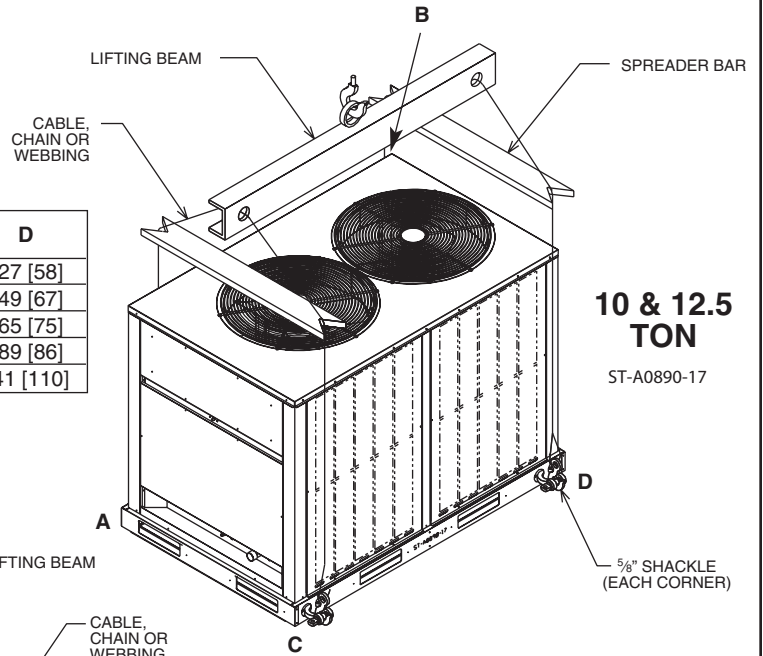

[] Designates metric conversions

INSTALLATION OF PIPING

WARNING

DO NOT USE OXYGEN TO PURGE LINES OR PRESSURE SYSTEM FOR LEAK TEST. OXYGEN REACTS VIOLENTLY WITH OIL, WHICH CAN CAUSE AN EXPLOSION RESULTING IN SEVERE PERSONAL INJURY OR DEATH.

IMPORTANT: CONDENSING UNITS ARE SHIPPED WITH A NITROGEN HOLDING CHARGE. EVACUATE CONDENSING UNIT BEFORE CHARGING WITH REFRIGERANT.

Once located, the condensing unit is ready to be interconnected with the evaporator using ONLY refrigeration grade dehydrated tubing. The following should be considered when connecting the tubing.

1. If used, it is recommended that the sight glass and liquid line solenoid valve be installed in the liquid line just prior to the evaporator.
2. Silver solder (such as silfos, Easy Flow, etc.) should be used for all refrigerant joints. Never use soft solder containing tin and lead to join refrigerant tubing.
3. Thoroughly clean all joints before fluxing. DO NOT USE ACID FLUX.
4. When fluxing, limit the application of paste to the minimum and always apply flux to the male portion of the connection.
5. Vapor lines should be insulated to prevent condensate drip. Use insulation of at least 1/2 inch wall thickness. The insulation should be installed on the tubing prior to making the sweat connections.
6. Insulate the liquid line whenever the heat pick-up or transfer can affect the sub-cooling.
7. Care should be taken to avoid transmission of noise or vibration to building structure.

**TABLE 2
REFRIGERANT PIPING DATA**

EQUIVALENT LENGTH (FT.) [m] OF STRAIGHT TYPE "L" TUBING FOR NON-FERROUS VALVES & FITTINGS (BRAZED)						
TUBE SIZE, INCHES [mm] O.D.	SOLENOID VALVE	ANGLE VALVE	SHORT RADIUS ELL	LONG RADIUS ELL	TEE LINE FLOW	TEE BRANCH FLOW
1/2 [13]	12 [3.7]	8.3 [2.5]	1.6 [0.5]	1.0 [0.3]	1.0 [0.3]	3.1 [0.9]
5/8 [16]	15 [4.6]	10.4 [3.2]	1.9 [0.8]	1.2 [0.4]	1.2 [0.4]	3.6 [1.1]
3/4 [19]	18 [5.5]	12.5 [3.8]	2.1 [0.7]	1.4 [0.4]	1.4 [0.4]	4.2 [1.3]
7/8 [22]	21 [6.4]	14.8 [4.4]	2.4 [0.7]	1.6 [0.5]	1.6 [0.5]	4.8 [1.5]
1 1/8 [29]	12 [3.7]	18.8 [5.7]	3.0 [0.9]	2.0 [0.6]	2.0 [0.6]	6.0 [1.8]
1 3/8 [35]	15 [4.6]	22.9 [7.0]	3.6 [1.1]	2.4 [0.7]	2.4 [0.7]	7.2 [2.2]
1 5/8 [41]	18 [5.5]	27.1 [8.3]	4.2 [1.3]	2.8 [0.8]	2.8 [0.8]	8.4 [2.6]
2 5/8 [54]	21 [6.4]	35.4 [10.8]	5.3 [1.6]	3.5 [1.1]	3.5 [1.1]	10.7 [3.3]

TYPICAL PIPING RECOMMENDATIONS

The following will be of help in accomplishing a successful installation.

1. Size liquid line for no more than 10°F loss which corresponds to approximately 50 PSIG pressure drop.
2. Size vapor lines for no more than 2°F loss which corresponds to approximately 5 PSIG pressure drop.

TYPICAL PIPING RECOMMENDATIONS

FIGURE 8
LIQUID LINE PRESSURE DROP PER 100 FEET
EQUIVALENT LENGTH (TYPE L COPPER TUBING)

LIQUID LINE PRESSURE DROP PER 100 FEET
[30.48 m] EQUIVALENT LENGTH
(TYPE L COPPER TUBING)

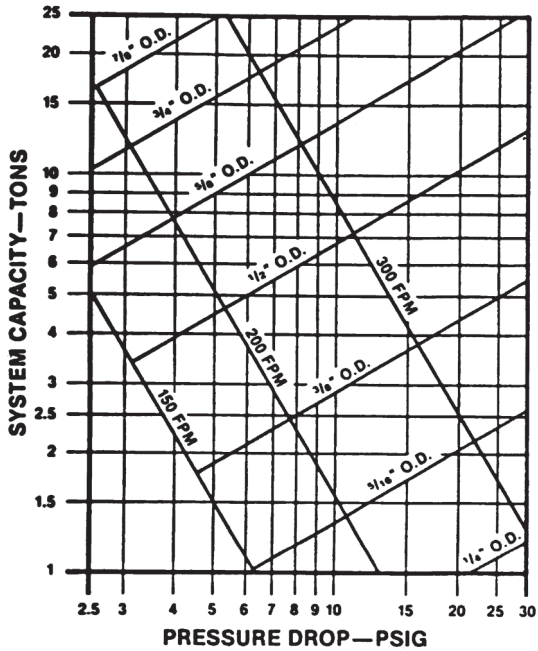

NOTES:

- 1) When evaporator coil is above condenser, the pressure drop due to vertical lift (.5 PSIG per foot of lift) [1.05 kPa per meter] **must** be added to the pressure drop derived from this curve.
- 2) Size liquid line for **no more** than 10°F [5.6°C] loss (approximately 50 PSIG total pressure drop).
- 3) **Do not oversize liquid line.** Oversized liquid lines add significantly to the amount of refrigerant required to charge the system.
- 4) The maximum recommended velocity with solenoid valves or other quick closing devices in the liquid line is 300 FPM [1.5 m/s].

FIGURE 9
SUCTION LINE SYSTEM CAPACITY LOSS IN PERCENT PER 100
FEET EQUIVALENT LENGTH (TYPE L COPPER TUBING)

VAPOR LINE SYSTEM CAPACITY LOSS
IN PERCENT PER 100 FEET [30.48 m]
EQUIVALENT LENGTH (TYPE L COPPER TUBING)

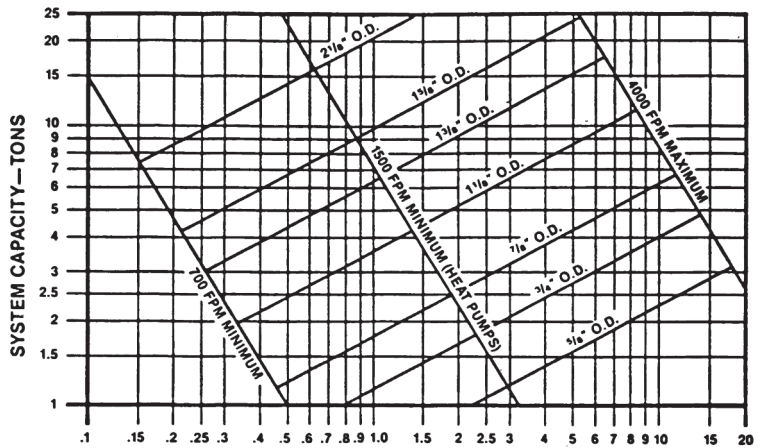

NOTES:

- 1) The minimum velocity line (700 fpm) [3.6 m/s] is recommended
- 2) For vapor pressure drop (PSIG), multiply percent (%) loss by 1.18.
- 3) Size vapor lines for no more than 2°F [1.1°C] loss which corresponds to approximately 5 PSIG pressure drop.
- 4) Pitch all horizontal vapor lines downward in the direction of flow (1/2" [12.7 mm] to 10' [3.0 m] run).

FIGURE 10
COIL ABOVE CONDENSING UNIT

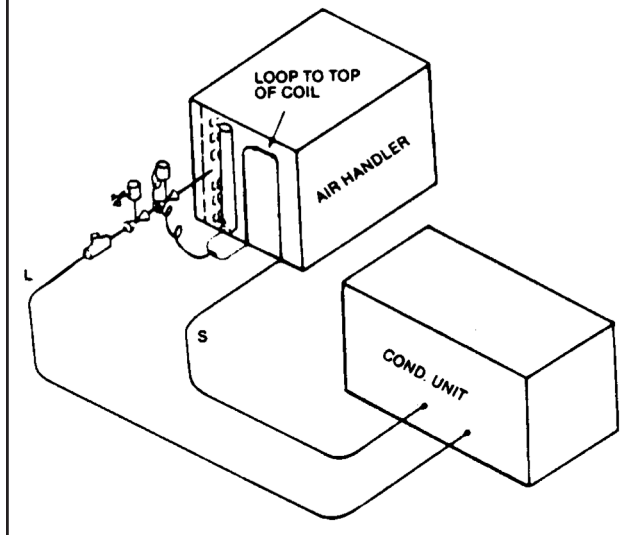
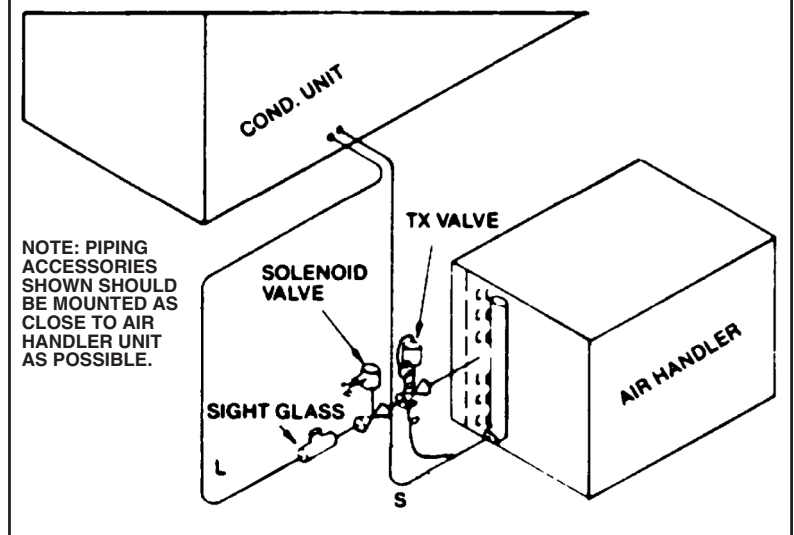

FIGURE 11
COIL BELOW CONDENSING UNIT



NOTE: PIPING ACCESSORIES SHOWN SHOULD BE MOUNTED AS CLOSE TO AIR HANDLER UNIT AS POSSIBLE.

NOTE: Unit has a scroll compressor which allows pressure to equalize in the system after shut-down. The liquid line solenoid valve may only be used for refrigerant isolation during the off-cycle. The solenoid should be wired in the "Y" circuit as shown in "Typical Field Wiring Connections".

3. When making up refrigerant piping, take every precaution to prevent dirt and moisture from entering the piping.
4. Locate the condensing unit and evaporator(s) as close together as possible to minimize piping runs.
5. Liquid or vapor lifts not to exceed 60 ft.
6. Line length between condenser and evaporator not to exceed 150' equivalent length.

TABLE 3

RECOMMENDED VAPOR AND LIQUID LINE SIZES TO VARIOUS LENGTH OF RUN				
EQUIVALENT LENGTH TO EVAPORATOR (FEET)	LIQUID LINE O.D. (INCHES)		VAPOR LINE O.D. (INCHES)	
	COOLING MODEL		COOLING MODEL	
	120	125	120	125
1 to 15	5/8	5/8	1 1/8	1 1/8
16 to 50	5/8	5/8	1 1/8	1 1/8
51 to 100	5/8	5/8	1 1/8	1 1/8
101 to 150	5/8	5/8	1 1/8	1 1/8

RECOMMENDED VAPOR AND LIQUID LINE SIZES TO VARIOUS LENGTH OF RUN						
EQUIVALENT LENGTH TO EVAPORATOR (FEET)	LIQUID LINE O.D. (INCHES)			VAPOR LINE O.D. (INCHES)		
	COOLING MODEL			COOLING MODEL		
	150	180	240	150	180	240
1 to 15	5/8	5/8	7/8	1 1/8	1 5/8	1 5/8
16 to 50	5/8	5/8	7/8	1 5/8	1 5/8	1 5/8
51 to 100	5/8	3/4	7/8	1 5/8	1 5/8	2 1/8
101 to 150	5/8	3/4	7/8	2 1/8	2 1/8	2 1/8

NOTE: Runs between condenser and evaporator not to exceed an equivalent length greater than 150 feet.

ELECTRICAL WIRING

NOTE: Field wiring must comply with the National Electric Code (NEC in Canada) and any local ordinance that may apply.

ELECTRICAL POWER

It is important that proper electrical power is available at the unit. Voltage must not vary more than 10% of that stamped on the rating plate. (See Table 1 on page 6.) Interphase voltage variation on three-phase units must not be more than 3%. Contact local power company for correction of improper voltage or phase unbalance.

IMPORTANT: Scroll compressors must be phased correctly for proper compressor rotation. If the compressor is noisy or if suction and discharge pressures do not appear normal, reverse any two power leads to the unit. Extended run time in reverse rotation will damage the compressor and lead to premature failure.

POWER WIRING

Power wiring should be run in grounded rain-tight conduit. Wire ampacity and wire size must comply with the National Electric Code (NEC in Canada) and all local codes and ordinances.

WIRE ROUTING

POWER WIRING MUST BE RUN IN CONDUIT. Conduit must be run through the connector panel below the service cover and attached to the bottom of the control box.

If low (extra-low in Canada) voltage control wire is run in conduit with power supply, Class I insulation is required. If run separate, Class II is required. Low voltage wiring may be run through the insulated bushing provided in the 7/8" hole in the connector panel then route to the control box.

WARNING

AFTER COMPLETION OF WIRING CHECK ALL ELECTRICAL CONNECTIONS, INCLUDING FACTORY WIRING WITHIN THE UNIT, AND MAKE SURE ALL CONNECTIONS ARE TIGHT, REPLACE AND SECURE ALL ELECTRICAL BOX COVERS AND ACCESS DOORS BEFORE LEAVING UNIT OR TURNING ON POWER TO CIRCUIT SUPPLY UNIT. FAILURE TO DO SO CAN CAUSE A FIRE OR ELECTRICAL SHOCK RESULTING IN PROPERTY DAMAGE, PERSONAL INJURY OR DEATH.

TABLE 4
FIELD WIRE SIZE FOR 24 VOLT THERMOSTAT

Thermostat Load - Amps	SOLID COPPER WIRE - AWG					
	16	14	12	10	10	10
3.0	16	14	12	10	10	10
2.5	16	14	12	12	10	10
2.0	18	16	14	12	12	10
	50	100	150	200	250	300

Length of Run - Feet (1)

(1) Wire length equals twice the run distance.

GROUNDING

WARNING

THIS UNIT MUST BE PERMANENTLY GROUNDED. A GROUND LUG IS PROVIDED NEAR THE CONTACTOR FOR A GROUND WIRE. FAILURE TO DO SO CAN CAUSE A FIRE OR ELECTRICAL SHOCK RESULTING IN PROPERTY DAMAGE, SEVERE PERSONAL INJURY OR DEATH.

A grounding lug is provided in control box for a ground wire.

Grounding may be accomplished by grounding the power line conduit to the unit.

THERMOSTAT

An appropriate thermostat should be mounted on an inside wall in a location where it will not be affected by the sun or drafts, from open doors or other sources. Install, level, and after installation check the thermostat calibration and recalibrate if necessary. Refer to thermostat manufacturer's information for additional installation, check-out and operation instructions.

**FIGURE 12
TYPICAL FIELD WIRING CONNECTIONS**

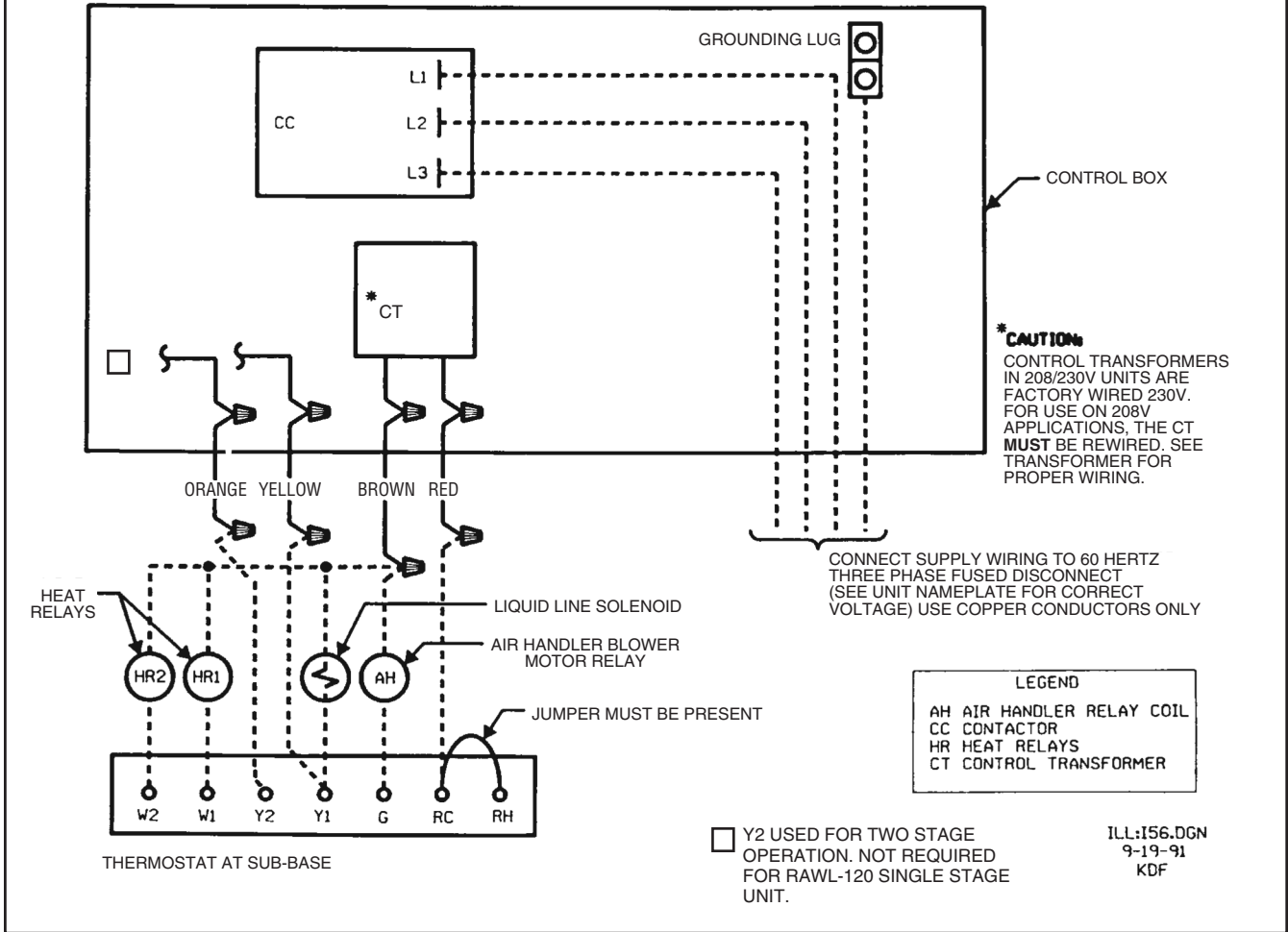

TOOLS REQUIRED FOR INSTALLING & SERVICING R-410A MODELS

Manifold Sets:

- Up to 800 PSIG High side
- Up to 250 PSIG Low Side
- 550 PSIG Low Side Retard

Manifold Hoses:

- Service Pressure Rating of 800 PSIG

Recovery Cylinders:

- 400 PSIG Pressure Rating
- Dept. of Transportation 4BA400 or 4BW400

CAUTION

R-410A systems operate at higher pressures than R-22 systems. Do not use R-22 service equipment or components on R-410A equipment.

SPECIFICATION OF R-410A:

Application: **R-410A is not a drop-in replacement for R-22;** equipment designs must accommodate its higher pressures. It cannot be retrofitted into R-22 condensing units.

Physical Properties: R-410A has an atmospheric boiling point of -62.9°F and its saturation pressure at 77°F is 224.5 psig.

Composition: R-410A is an azeotropic mixture of 50% by weight difluoromethane (HFC-32) and 50% by weight pentafluoroethane (HFC-125).

Pressure: The pressure of R-410A is approximately 60% (1.6 times) greater than R-22. Recovery and recycle equipment, pumps, hoses and the like need to have design pressure ratings appropriate for R-410A. *Manifold sets need to range up to 800 psig high-side and 250 psig low-side with a 550 psig low-side retard. Hoses need to have a service pressure rating of 800 psig. Recovery cylinders need to have a 400 psig service pressure rating.* DOT 4BA400 or 4BW400.

Combustibility: At pressures above 1 atmosphere, mixture of R-410A and air can become combustible. **R-410A and air should never be mixed in tanks or supply lines, or be allowed to accumulate in storage tanks. Leak checking should never be done with a mixture of R-410A and air.** Leak checking can be performed safely with nitrogen or a mixture of R-410A and nitrogen.

QUICK REFERENCE GUIDE FOR R-410A

- R-410A refrigerant operates at approximately 60% higher pressure (1.6 times) than R-22. Ensure that servicing equipment is designed to operate with R-410A.
- R-410A refrigerant cylinders are pink in color.
- R-410A, as with other HFC's is only compatible with POE oils.
- Vacuum pumps will not remove moisture from oil.
- R-410A systems are to be charged with liquid refrigerants. Prior to March 1999, R-410A refrigerant cylinders had a dip tube. These cylinders should be kept upright for equipment charging. Post March 1999 cylinders do not have a dip tube and should be inverted to ensure liquid charging of the equipment.
- Do not install a suction line filter drier in the liquid line.
- A liquid line filter drier is shipped with every unit. Only manufacturer approved liquid line filter driers can be used. These filter driers are rated for minimum working pressure of 600 psig.
- Desiccant (drying agent) must be compatible for POE oils and R-410A.

REPLACEMENT UNITS

To prevent failure of a new condensing unit, the existing evaporator tubing system must be correctly sized and cleaned or replaced. Care must be exercised that the expansion device is not plugged. For new and replacement units, a liquid line filter drier should be installed and refrigerant tubing should be properly sized. Test the oil for acid. If positive, a suction line filter drier is mandatory.

IMPORTANT: WHEN REPLACING AN R-22 UNIT WITH AN R-410A UNIT, EITHER REPLACE THE LINE SET OR ENSURE THAT THE EXISTING LINE SET IS THOROUGHLY CLEANED OF ANY OLD OIL OR DEBRIS.

EVAPORATOR COIL

REFER TO EVAPORATOR COIL MANUFACTURER'S INSTALLATION INSTRUCTIONS.

IMPORTANT: The manufacturer is not responsible for the performance and operation of a mismatched system, or for a match listed with another manufacturer's coil.

CAUTION

Only use evaporators approved for use on R-410A systems. Use of existing R-22 evaporators can introduce mineral oil to the R-410A refrigerant forming two different liquids and decreasing oil return to the compressor. This can result in compressor failure.

LEAK TESTING

Pressurize line set and coil through service fittings with dry nitrogen to 150 PSIG maximum. Leak test all joints using liquid detergent. If a leak is found, repair.

WARNING

DO NOT USE OXYGEN TO PURGE LINES OR PRESSURE SYSTEM FOR LEAK TEST. OXYGEN REACTS VIOLENTLY WITH OIL, WHICH CAN CAUSE AN EXPLOSION RESULTING IN SEVERE PERSONAL INJURY OR DEATH.

**TABLE 5
BASIC SYSTEM CHARGE***

RAWL-120	RAWL-125
339 oz. [9610 g]	300 oz. [8505 g]
RAWL-150	RAWL-180
378 oz. [10716 g]	506 oz. [14345 g]
RAWL-240	
655 oz. [18569 g]	

*System with 0 Feet of Tubing

EVACUATION AND CHARGING

The evacuation of any system component that has been exposed to atmosphere or lost its charge is essential before charging. Never attempt to operate a system while it is under a vacuum.

NOTE: The condensing unit is shipped with a holding charge of dry nitrogen which must be purged from the unit before evacuation.

1. Since the condensing unit itself must be evacuated, open the vapor and liquid service valves.
2. Use a refrigeration type vacuum pump capable of evacuation in the 500 micron range.
3. Connect the vacuum pump to the service manifold assembly with a pressure gauge that will read 30 inches vacuum. Connect the service manifold to the vapor line service port. ("Low" shown on label.)
4. With an accurate scale, set refrigerant tank up so its weight can be measured while in a position to charge liquid. (Unit must be off.) Energize liquid line solenoid valve by wiring valve to 24V power supply (or open by manual stem if applicable).
5. Connect to the liquid line service port ("High" shown on label) and evacuate the system below 500 microns.
6. The refrigerant system will now be free of noncondensables.
7. Remove vacuum pump from 3-way valve.
8. Install refrigerant tank (liquid charging) to liquid line service valve.
9. Before tightening, purge tank and service valve hose.
10. Note weight of refrigerant tank. Do not charge more than the sum of the basic system charge plus the charge per foot of tubing shown in Table 5.
11. De-energize liquid line solenoid valve, if so equipped. Open refrigerant tank valve. Allow pressure in tank and unit to equalize.
12. Close off service valve to liquid line service port and note weight of refrigerant tank.

13. Re-wire liquid line solenoid to thermostat control. Close main disconnect switch and turn thermostat to lowest setting.
14. Charge unit per Table 5 and the tubing allowance.
15. Adjust refrigerant charge to obtain pressures indicated in the charge chart.
16. Note weight of refrigerant tank.
17. When system has stabilized, check superheat at the suction line service valve. The actual line temperature should be 8° to 20°F higher than the saturation temperature corresponding to the vapor pressure. If superheat is measured at evaporator, the actual line temperature should be 6° to 10° higher than the saturation temperature corresponding to the vapor pressure.
18. Close service ports on vapor and liquid valves. Remove service gauges.
19. Replace service port caps and valve stem caps. These caps must be replaced to prevent leaks.
20. Record total charge quantity on rating plate.

**TABLE 6
REQUIRED OUNCES OF REFRIGERANT CHARGE PER FOOT OF TUBING**

Tube Size O.D., In.	Liquid oz/ft	Vapor oz/ft
1/2	1.06	0.04
5/8	1.65	0.07
3/4	2.46	0.10
7/8	3.28	0.13
1 1/8		0.22
1 3/8		0.34
1 5/8		0.48
2 1/8		0.84

Quantities based on 110°F liquid and 45°F vapor.

FINAL LEAK TESTING

After the unit has been properly evacuated and charged, a halogen leak detector should be used to detect leaks in the system. All piping within the condensing unit, evaporator, and interconnecting tubing should be checked for leaks. If a leak is detected, the refrigerant should be recovered before repairing the leak. The Clean Air Act prohibits releasing refrigerant into the atmosphere.

**TABLE 7
CHARGING HINTS**

SYMPTOM	POSSIBLE CAUSE	REMEDY
High head pressure condensing unit	a. Air flow to or from condenser restricted or dirty condenser b. Faulty condenser fan or motor. c. Overcharge of refrigerant d. Air in system.	a. Remove obstruction, relocate, if necessary clean condenser. b. Replace. c. Reduce charge. d. Evacuate and recharge.
Low head pressure	a. Short of refrigerant. b. Low evaporator air flow.	a. Check for leak, add charge. b. Increase blower speed, check filters.
Low vapor & hot compressor	a. Short of refrigerant.	a. Check for leak—add refrigerant.
Excessive sweating	a. Low indoor airflow b. Excess refrigerant	a. Increase speed of air handler blower or reduce restriction—replace air filter. b. Slowly reduce charge.

PRE-START CHECK

- | | | |
|------------------------------|-----------------------------|---|
| <input type="checkbox"/> YES | <input type="checkbox"/> NO | 1. Is condensing unit properly located and level? |
| <input type="checkbox"/> YES | <input type="checkbox"/> NO | 2. Is air free to travel to and from condensing unit? |
| <input type="checkbox"/> YES | <input type="checkbox"/> NO | 3. Is the wiring correct and according to the unit wiring diagram? |
| <input type="checkbox"/> YES | <input type="checkbox"/> NO | 4. Are wiring connections tight? (Including those in unit and compressor electrical box.) |
| <input type="checkbox"/> YES | <input type="checkbox"/> NO | 5. Is the unit properly grounded? |
| <input type="checkbox"/> YES | <input type="checkbox"/> NO | 6. Is circulating air blower correctly wired? |
| <input type="checkbox"/> YES | <input type="checkbox"/> NO | 7. Is condensing unit properly fused? |
| <input type="checkbox"/> YES | <input type="checkbox"/> NO | 8. Is the thermostat level, correctly wired and in a good location? |
| <input type="checkbox"/> YES | <input type="checkbox"/> NO | 9. Is the ductwork correctly sized, run, taped and insulated? |
| <input type="checkbox"/> YES | <input type="checkbox"/> NO | 10. Is refrigerant tubing neatly run and vapor line thoroughly insulated? |
| <input type="checkbox"/> YES | <input type="checkbox"/> NO | 11. Is condensate drain line properly sized, run, trapped and pitched? |
| <input type="checkbox"/> YES | <input type="checkbox"/> NO | 12. Are refrigerant connections tight and leak tested? |
| <input type="checkbox"/> YES | <input type="checkbox"/> NO | 13. Is filter clean and in place? |
| <input type="checkbox"/> YES | <input type="checkbox"/> NO | 14. Does the condenser fan turn free without rubbing? |
| <input type="checkbox"/> YES | <input type="checkbox"/> NO | 15. Is the fan tight on the fan shaft? |
| <input type="checkbox"/> YES | <input type="checkbox"/> NO | 16. Are all covers and access panels in place to prevent air loss? |

MAINTENANCE AND OPERATION

1. All access panels must be in place when unit is in operation.
2. For maximum efficiency, the condenser coil must be kept clean. Periodic inspections, depending on local conditions are recommended. If it is necessary to clean the condenser coil, use a common garden hose.
3. Never operate the unit without filters installed in the air handler.

SEQUENCE OF OPERATION – RAWL-120

1. When the room thermostat is set on “Cool”, “Fan Auto”, and the temperature is higher than the thermostat setting, the thermostat “Y1” circuit closes and energizes the compressor contactor (CC) through the closed contacts of the high pressure and low pressure controls. Power to the crankcase heater will be de-energized by the auxiliary contacts (AUX-1).
2. Simultaneously, the “G” circuit provides power to the indoor blower motor circuit and starts indoor air circulation through the evaporator coil.

3. When the discharge pressure increases to 450 psig, the contacts on the low ambient control (LAC) will allow supply power to start the outdoor fan motors (ODF) which begin to pull air through the condenser coils.
4. The system will continue operation, as long as the room thermostat “Y1” circuit and all safety device contacts are closed. The low ambient control (LAC) will open and close, allowing the outdoor fans to maintain discharge pressure between 250 and 450 psig.
5. When the thermostat is satisfied, the “Y1” circuit will open and de-energize the compressor contactor (CC), stopping compressor operation and closing the auxiliary contacts (AUX-1) which energizes the crankcase heater (CCH).
6. The thermostat “G” circuit will stop blower operation.

SEQUENCE OF OPERATION – RAWL-125, -150, -180, -240, Two Stage

1. When the room thermostat is set on “Cool”, “Fan Auto”, and the temperature is higher than the thermostat setting, the thermostat “Y1” circuit closes and energizes the number one compressor contactor (CC1) through the closed cooling relay (R) contacts. Power to the crankcase heater (CCH1) will be de-energized by the auxiliary contacts (AUX-1).
2. Simultaneously, the “G” circuit provides power to the indoor blower motor circuit and starts indoor air circulation through the evaporator coil.
3. When the discharge pressure increases to 450 psig, the contacts on the low ambient control (LAC) will allow supply power to start the outdoor fan motors (ODF) which begin to pull air through the condenser coils. The system is now in first stage cooling, operating at near fifty percent of full load capacity.
4. If the temperature at the thermostat continues to increase, the thermostat “Y2” circuit closes and after a full 30 second delay, power passes through the time delay control (TDC) and energizes the number two compressor contactor (CC2) through the second set of closed cooling relay (R) contacts. Power to the crankcase heater (CCH2) will be de-energized by the auxiliary contacts (AUX-2).
5. The system will continue cooling at maximum capacity, as long as the room thermostat is demanding full load and all safety device contacts are closed. The low ambient control (LAC) will open and close, allowing the outdoor fans to maintain discharge pressure between 250 and 450 psig.
6. As the temperature at the thermostat drops enough to satisfy “Y2”, the circuit will open and de-energize the compressor contactor (CC2), stopping compressor operation and closing the auxiliary contacts (AUX-2), which energizes the crankcase heater (CCH2).
7. When continued cooling satisfies the “Y1” circuit, it will open and de-energize the compressor contactor (CC1), stopping compressor operation and closing the auxiliary contacts (AUX-1), which energizes the crankcase heater (CCH1).
8. The thermostat “G” circuit will stop blower operation.

CRANKCASE HEATERS

All units are equipped with a crankcase heater. These heaters are factory wired in such a manner that they are in operation whenever the main power supply to the unit is “on” and compressors are “off.” Before starting the equipment after prolonged shutdown or at the time of initial start-up, be sure that the circuits to the condensing units are closed for at least 12 hours.

CONTACTOR (CC)

The contactor is an electrical switch which operates the compressor and condenser fans. Relay activates contactor when safety circuit is made.

HIGH PRESSURE SWITCH (HPC)

Opens the contactor circuit at 610 psig—Manual Reset—check for cause of tripping before putting unit back in service.

WARNING

DO NOT WIRE AROUND THE HIGH PRESSURE SWITCH. FAILURE TO FOLLOW THIS WARNING CAN CAUSE AN EXPLOSION RESULTING IN PERSONAL INJURY OR DEATH.

LOW PRESSURE SWITCH (LPC)

Acts as safety against loss of refrigerant. Opens at 50 psig, auto reset.

LOW AMBIENT CONTROL (LAC)

Cycles outdoor fans to maintain adequate discharge pressure. Opens at 250 psig and closes at 450 psig.

ORDER PARTS

When reporting shortages or damaged parts, or when ordering repair parts, give the complete unit model and serial numbers which are stamped on the Unit Rating Plate.

**MODEL -AWL-120
10 TON CONDENSING UNIT 60 HZ. REFRIGERANT R-410A**

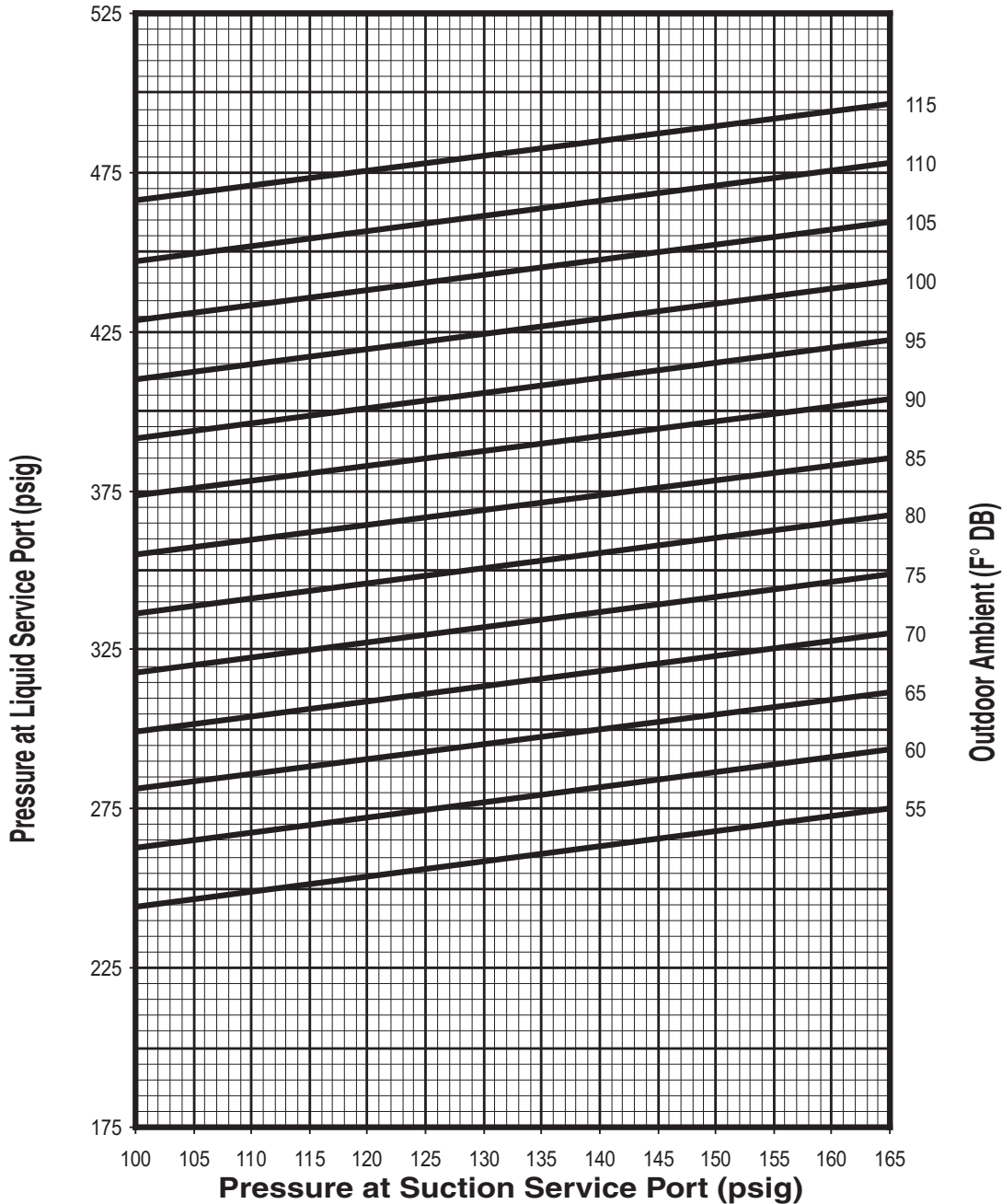

REQUIRED OUNCES R-410A CHARGE PER FOOT OF TUBING		
TUBE SIZE O.D. IN.	LIQUID LINE	VAPOR LINE
1/2	1.06	
5/8	1.65	
1-1/8		.22
1-3/8		.34

REFRIGERANT REQUIRED: 300 OZ. WITH 0 FT. OF SUCTION AND LIQUID LINE.

CAUTION: BEFORE FINAL REFRIGERANT CHECK, INDOOR AIR TEMPERATURE SHOULD BE AT COMFORT CONDITIONS FOR MOST ACCURATE RESULTS.

INSTRUCTIONS:

1. CONNECT PRESSURE GUAGES TO SUCTION AND LIQUID PORTS ON UNIT.
2. MEASURE AIR TEMPERATURE TO OUTDOOR COIL.
3. PLACE AN "X" ON THE APPROPRIATE CHART WHERE THE SUCTION AND LIQUID PRESSURES CROSS.
4. IF "X" IS BELOW AMBIENT TEMPERATURE LINE, ADD CHARGE AND REPEAT STEP 3.
5. IF "X" IS ABOVE AMBIENT TEMPERATURE LINE, RECOVER EXCESS CHARGE AND REPEAT STEP 3.
6. IF CONDENSER FANS ARE NOT RUNNING, THE HEAD PRESSURE CONTROL MAY REQUIRE JUMPERING.

**MODEL -AWL-125
10 TON CONDENSING UNIT 60 HZ. REFRIGERANT R-410A**

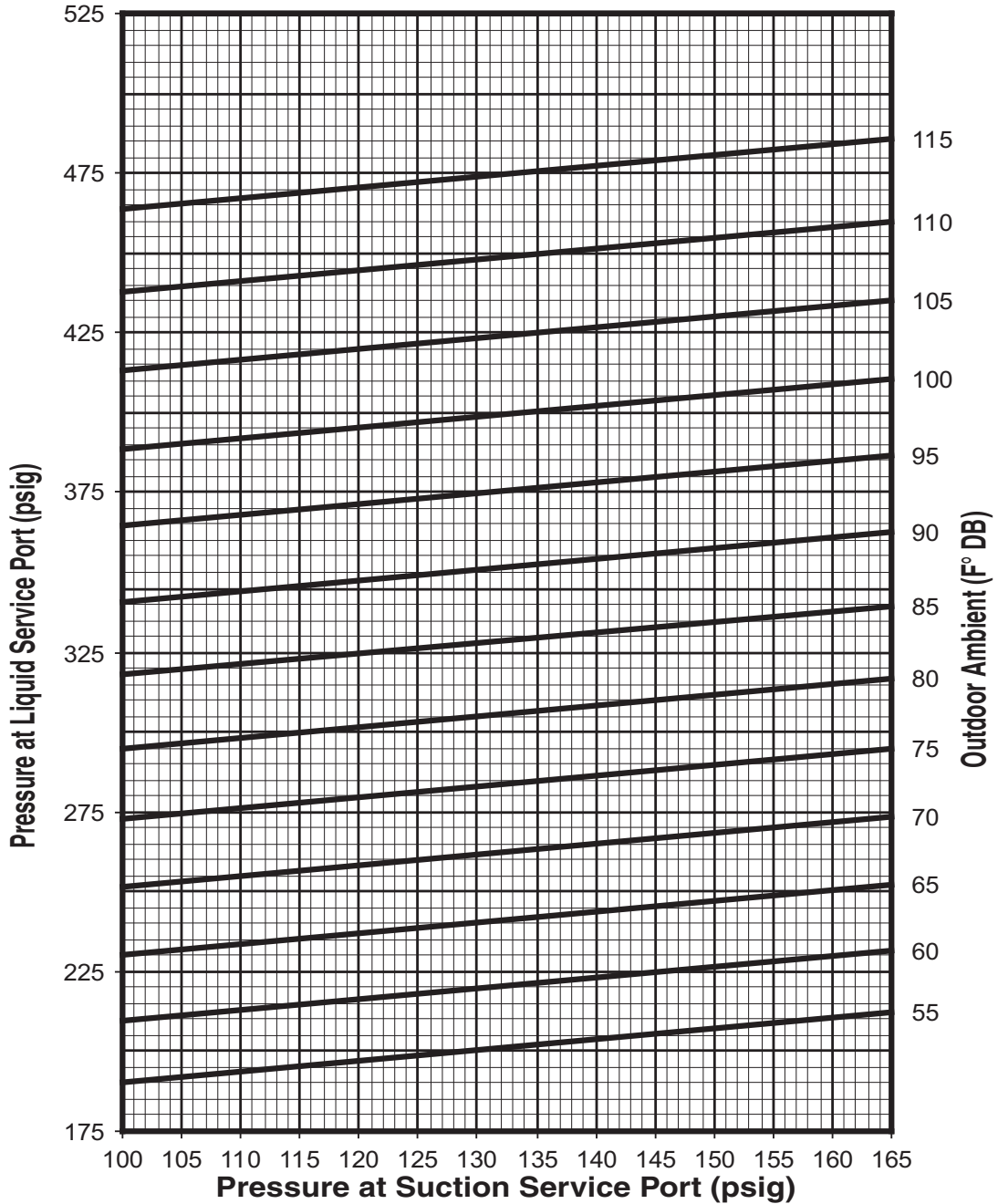

REQUIRED OUNCES R-410A CHARGE PER FOOT OF TUBING		
TUBE SIZE O.D. IN.	LIQUID LINE	VAPOR LINE
1/2	1.06	
5/8	1.65	
1-1/8		.22
1-3/8		.34

REFRIGERANT REQUIRED: 339 OZ. WITH 0 FT. OF SUCTION AND LIQUID LINE.

CAUTION: BEFORE FINAL REFRIGERANT CHECK, INDOOR AIR TEMPERATURE SHOULD BE AT COMFORT CONDITIONS FOR MOST ACCURATE RESULTS.

INSTRUCTIONS:

1. CONNECT PRESSURE GUAGES TO SUCTION AND LIQUID PORTS ON UNIT.
2. MEASURE AIR TEMPERATURE TO OUTDOOR COIL.
3. PLACE AN "X" ON THE APPROPRIATE CHART WHERE THE SUCTION AND LIQUID PRESSURES CROSS.
4. IF "X" IS BELOW AMBIENT TEMPERATURE LINE, ADD CHARGE AND REPEAT STEP 3.
5. IF "X" IS ABOVE AMBIENT TEMPERATURE LINE, RECOVER EXCESS CHARGE AND REPEAT STEP 3.
6. IF CONDENSER FANS ARE NOT RUNNING, THE HEAD PRESSURE CONTROL MAY REQUIRE JUMPERING.

**MODEL -AWL-150
12.5 TON CONDENSING UNIT 60 HZ. REFRIGERANT R-410A**

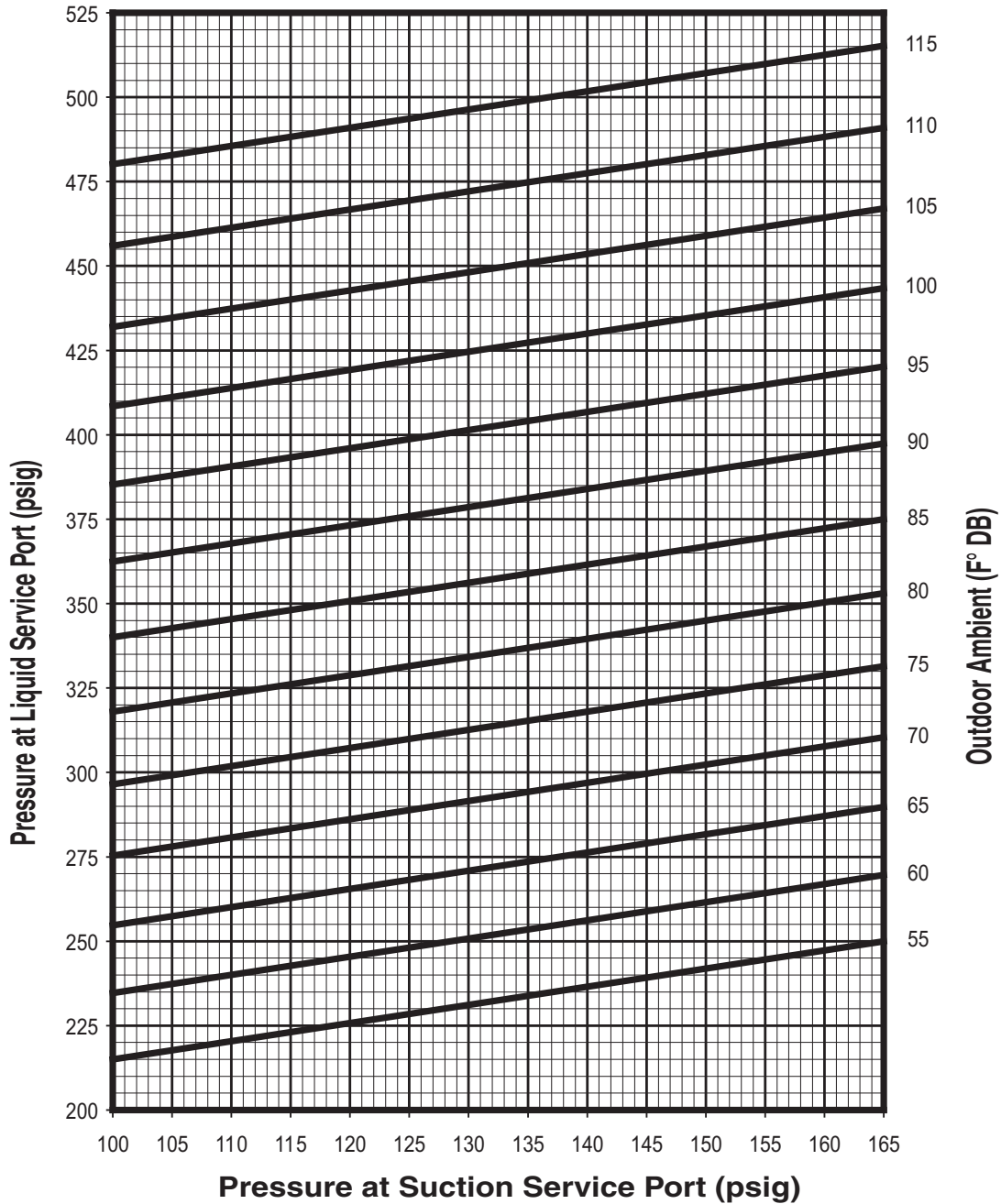

REQUIRED OUNCES R-410A CHARGE PER FOOT OF TUBING		
TUBE SIZE O.D. IN.	LIQUID LINE	VAPOR LINE
1/2	1.06	
5/8	1.65	
1-1/8		.22
1-3/8		.34

REFRIGERANT REQUIRED: 378 OZ. WITH 0 FT. OF SUCTION AND LIQUID LINE.

CAUTION: BEFORE FINAL REFRIGERANT CHECK, INDOOR AIR TEMPERATURE SHOULD BE AT COMFORT CONDITIONS FOR MOST ACCURATE RESULTS.

INSTRUCTIONS:

1. CONNECT PRESSURE GAUGES TO SUCTION AND LIQUID PORTS ON UNIT.
2. MEASURE AIR TEMPERATURE TO OUTDOOR COIL.
3. PLACE AN "X" ON THE APPROPRIATE CHART WHERE THE SUCTION AND LIQUID PRESSURES CROSS.
4. IF "X" IS BELOW AMBIENT TEMPERATURE LINE, ADD CHARGE AND REPEAT STEP 3.
5. IF "X" IS ABOVE AMBIENT TEMPERATURE LINE, RECOVER EXCESS CHARGE AND REPEAT STEP 3.
6. IF CONDENSER FANS ARE NOT RUNNING, THE HEAD PRESSURE CONTROL MAY REQUIRE JUMPERING.

92-102644-09-00

**MODEL -AWL-180
15 TON CONDENSING UNIT 60 HZ. REFRIGERANT R-410A**

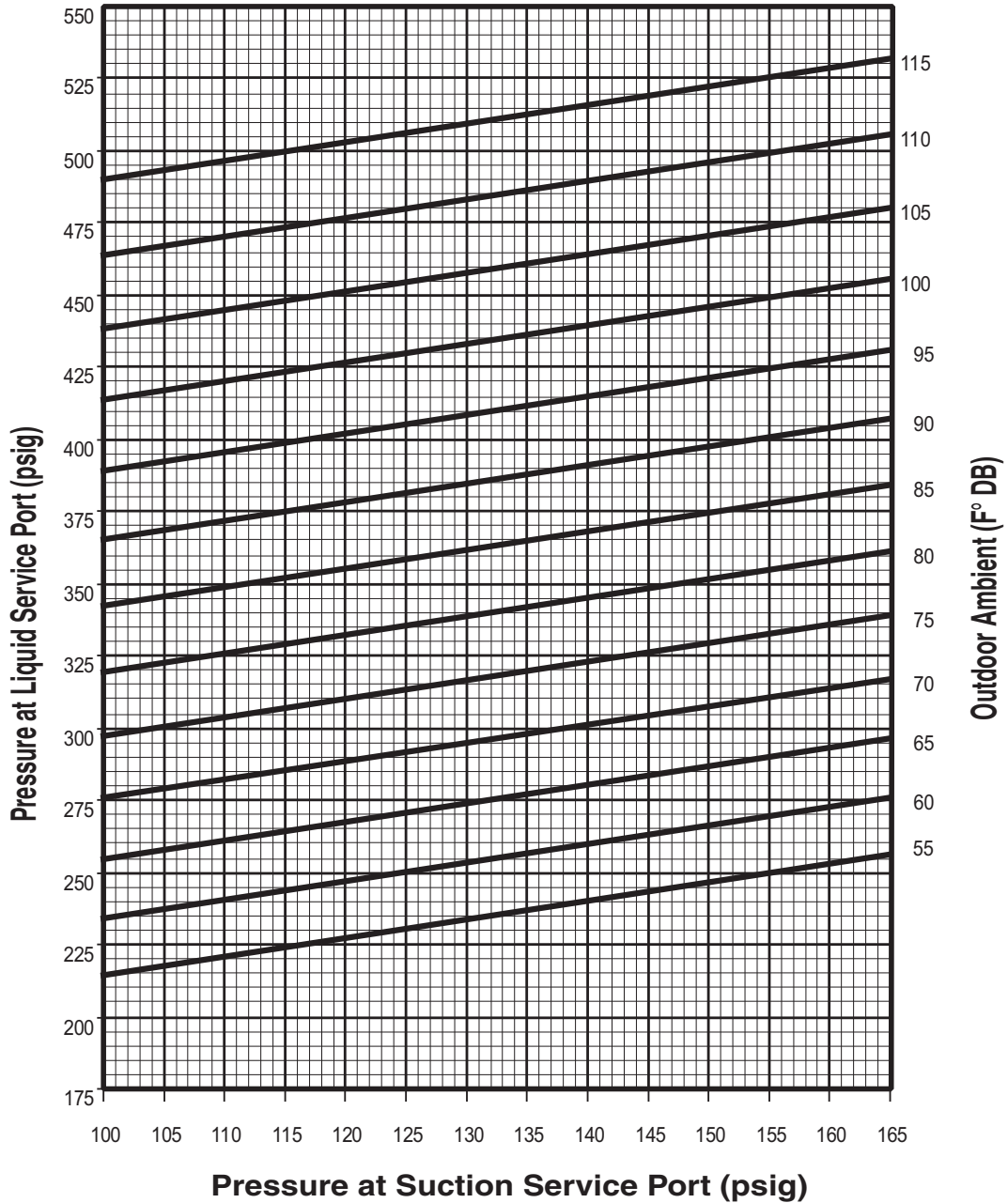

REQUIRED OUNCES R-410A CHARGE PER FOOT OF TUBING		
TUBE SIZE O.D. IN.	LIQUID LINE	VAPOR LINE
1/2	1.06	
5/8	1.65	
1-1/8		.22
1-3/8		.34

REFRIGERANT REQUIRED: 506 OZ. WITH 0 FT. OF SUCTION AND LIQUID LINE.

CAUTION: BEFORE FINAL REFRIGERANT CHECK, INDOOR AIR TEMPERATURE SHOULD BE AT COMFORT CONDITIONS FOR MOST ACCURATE RESULTS.

INSTRUCTIONS:

1. CONNECT PRESSURE GUAGES TO SUCTION AND LIQUID PORTS ON UNIT.
2. MEASURE AIR TEMPERATURE TO OUTDOOR COIL.
3. PLACE AN "X" ON THE APPROPRIATE CHART WHERE THE SUCTION AND LIQUID PRESSURES CROSS.
4. IF "X" IS BELOW AMBIENT TEMPERATURE LINE, ADD CHARGE AND REPEAT STEP 3.
5. IF "X" IS ABOVE AMBIENT TEMPERATURE LINE, RECOVER EXCESS CHARGE AND REPEAT STEP 3.
6. IF CONDENSER FANS ARE NOT RUNNING, THE HEAD PRESSURE CONTROL MAY REQUIRE JUMPERING.

92-102644-11-00

**MODEL -AWL-240
20 TON CONDENSING UNIT 60 HZ. REFRIGERANT R-410A**

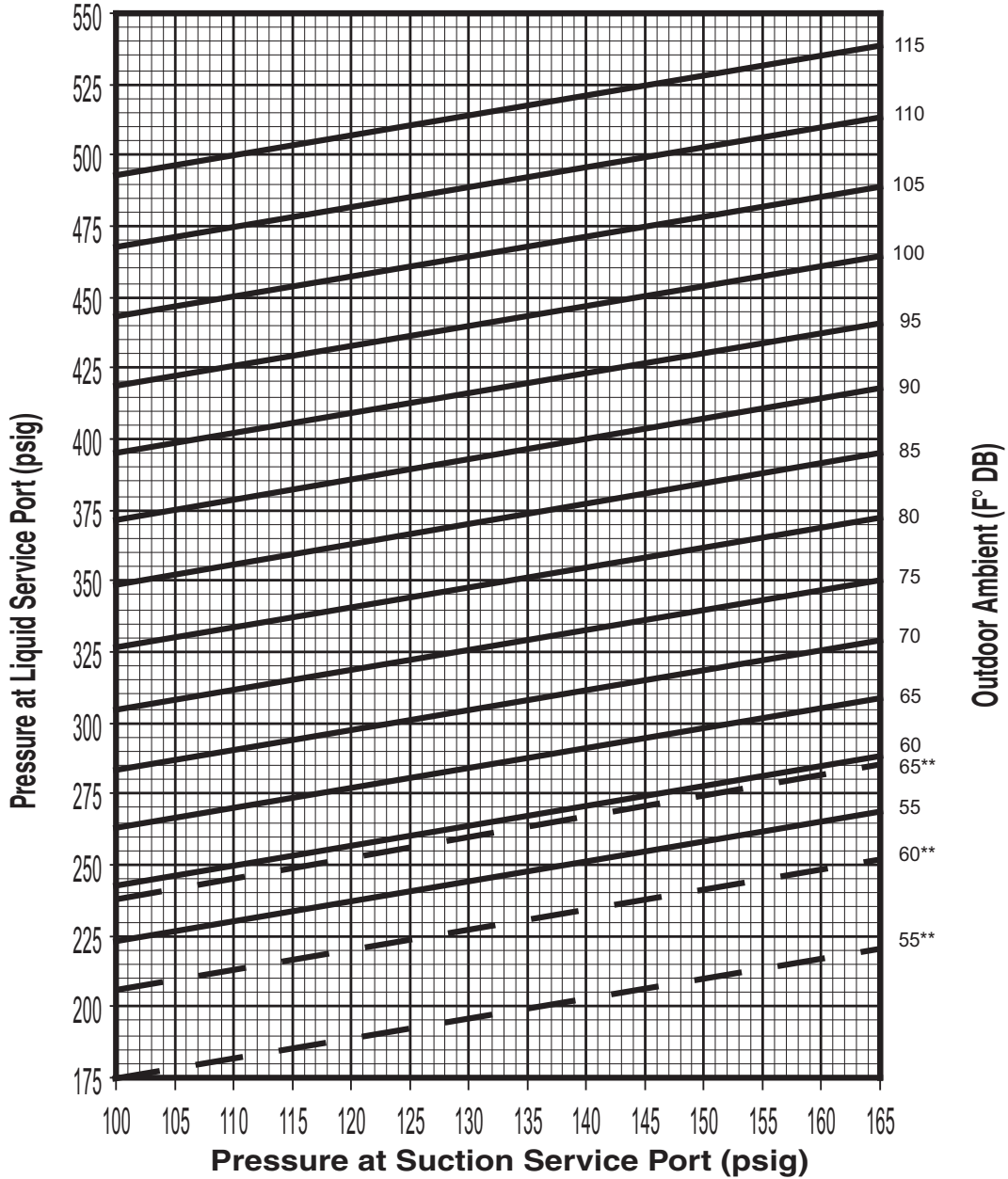

REQUIRED OUNCES R-410A CHARGE PER FOOT OF TUBING		
TUBE SIZE O.D. IN.	LIQUID LINE	VAPOR LINE
1/2	1.06	
5/8	1.65	
1-1/8		.22
1-3/8		.34

REFRIGERANT REQUIRED: 655 OZ. WITH 0 FT. OF SUCTION AND LIQUID LINE.

CAUTION: BEFORE FINAL REFRIGERANT CHECK, INDOOR AIR TEMPERATURE SHOULD BE AT COMFORT CONDITIONS FOR MOST ACCURATE RESULTS.

INSTRUCTIONS:

1. CONNECT PRESSURE GUAGES TO SUCTION AND LIQUID PORTS ON UNIT.
2. MEASURE AIR TEMPERATURE TO OUTDOOR COIL.
3. PLACE AN "X" ON THE APPROPRIATE CHART WHERE THE SUCTION AND LIQUID PRESSURES CROSS.
4. IF "X" IS BELOW AMBIENT TEMPERATURE LINE, ADD CHARGE AND REPEAT STEP 3.
5. IF "X" IS ABOVE AMBIENT TEMPERATURE LINE, RECOVER EXCESS CHARGE AND REPEAT STEP 3.
6. IF CONDENSER FANS ARE NOT RUNNING, THE HEAD PRESSURE CONTROL MAY REQUIRE JUMPERING.

** DOTTED LINES INDICATE ONLY 1 COMPRESSOR OPERATING.

TROUBLESHOOTING CHART

▲ WARNING

DISCONNECT ALL POWER TO UNIT BEFORE SERVICING. CONTACTOR MAY BREAK ONLY ONE SIDE. FAILURE TO SHUT OFF POWER CAN CAUSE ELECTRICAL SHOCK RESULTING IN PERSONAL INJURY OR DEATH.

SYMPTOM	POSSIBLE CAUSE	SOLUTION
Unit will not run	<ul style="list-style-type: none"> • Power off or loose electrical connection • Thermostat out of calibration-set too high • Defective contactor • Blown fuses or tripped breaker • Transformer defective • High pressure control open (if provided) • Interconnecting low voltage wiring damaged. 	<ul style="list-style-type: none"> • Check for correct voltage at compressor contactor in control box • Reset • Check for 24 volts at contactor coil - replace if contacts are open • Replace fuses or reset breaker • Check wiring-replace transformer • Reset-also see high head pressure remedy • Replace thermostat wiring
Condenser fan runs, compressor doesn't	<ul style="list-style-type: none"> • Loose connection • Compressor stuck, grounded or open motor winding, open internal overload. • Low voltage condition 	<ul style="list-style-type: none"> • Check for correct voltage at compressor - check & tighten all connections • Wait at least 2 hours for overload to reset. If still open, replace the compressor. • At compressor terminals, voltage must be within 10% of rating plate volts when unit is operating.
Insufficient cooling	<ul style="list-style-type: none"> • Improperly sized unit • Improper airflow • Incorrect refrigerant charge • Air, non-condensibles or moisture in system • Incorrect voltage 	<ul style="list-style-type: none"> • Recalculate load • Check - should be approximately 400 CFM per ton. • Charge per procedure attached to unit service panel • Recover refrigerant, evacuate & recharge, add filter drier • At compressor terminals, voltage must be within 10% of rating plate volts when unit is operating.
Compressor short cycles	<ul style="list-style-type: none"> • Incorrect voltage • Defective overload protector • Refrigerant undercharge 	<ul style="list-style-type: none"> • At compressor terminals, voltage must be – 10% of nameplate marking when unit is operating • Replace - check for correct voltage • Add refrigerant
Registers sweat	<ul style="list-style-type: none"> • Low evaporator airflow 	<ul style="list-style-type: none"> • Increase speed of blower or reduce restriction - replace air filter
High head-low vapor pressures	<ul style="list-style-type: none"> • Restriction in liquid line, expansion device or filter drier • TXV does not open 	<ul style="list-style-type: none"> • Remove or replace defective component • Replace TXV
High head-high or normal vapor pressure - Cooling mode	<ul style="list-style-type: none"> • Dirty condenser coil • Refrigerant overcharge • Condenser fan not running • Air or non-condensibles in system 	<ul style="list-style-type: none"> • Clean coil • Correct system charge • Repair or replace • Recover refrigerant, evacuate & recharge
Low head-high vapor pressures	<ul style="list-style-type: none"> • TX valve open • Defective Compressor valves 	<ul style="list-style-type: none"> • Check bulb mounting - replace valve • Replace compressor
Low vapor - cool compressor - iced evaporator coil	<ul style="list-style-type: none"> • Low evaporator airflow • Operating below 65°F outdoors • Moisture in system 	<ul style="list-style-type: none"> • Increase speed of blower or reduce restriction - replace air filter • Check low ambient switch • Recover refrigerant - evacuate & recharge - add filter drier
High vapor pressure	<ul style="list-style-type: none"> • Excessive load • Defective compressor 	<ul style="list-style-type: none"> • Recheck load calculation • Replace
Fluctuating head & vapor pressures	<ul style="list-style-type: none"> • TXV hunting • Air or non-condensibles in system 	<ul style="list-style-type: none"> • Check TXV bulb clamp - check air distribution on coil - replace TXV • Recover refrigerant, evacuate & recharge
Gurgle or pulsing noise at expansion device or liquid line	<ul style="list-style-type: none"> • Air or non-condensibles in system 	<ul style="list-style-type: none"> • Recover refrigerant, evacuate & recharge

**FIGURE 13
RAWL-120 WIRING SCHEMATIC
SINGLE STAGE**

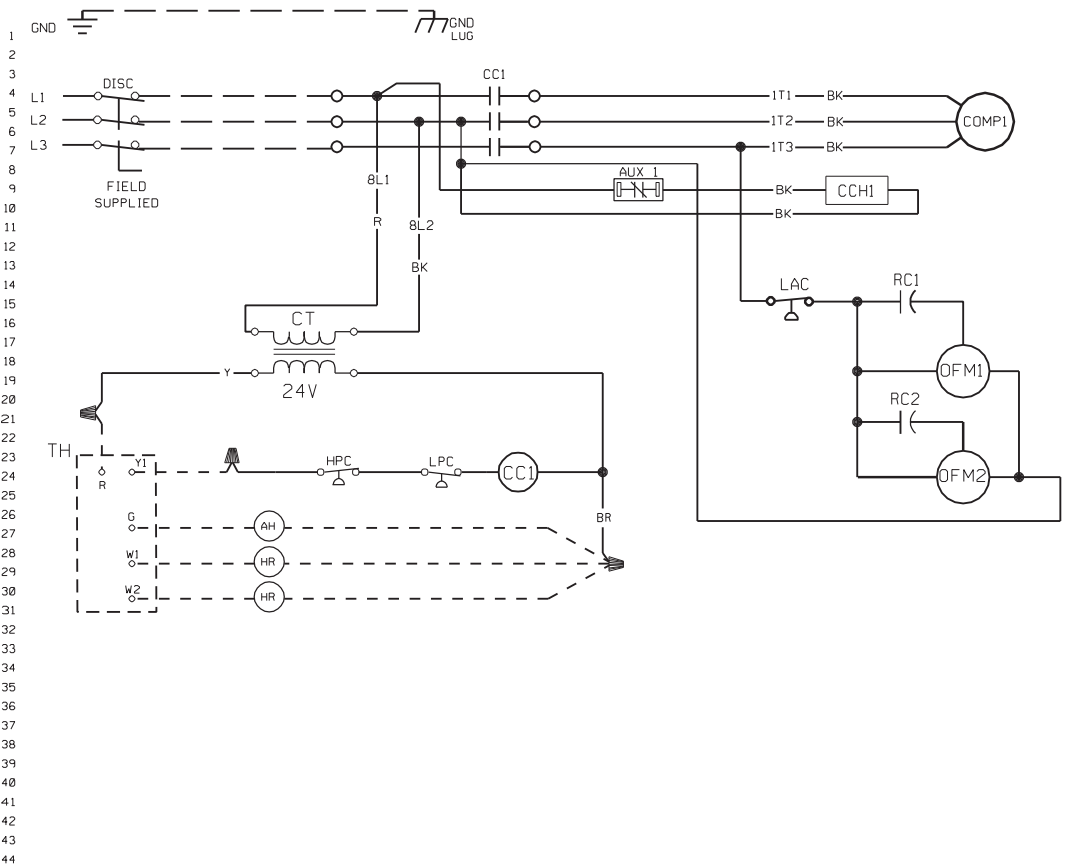

DWG. NO. 90-42663-10	CC	COMPRESSOR CONTACTOR
	CCH	CRANKCASE HEATER
	COMP	COMPRESSOR
	CT	CONTROL TRANSFORMER
	DISC	DISCONNECT SWITCH
	FC	FAN MOTOR CONTACTOR
	GND	GROUND
	HEAT	HEATER RELAY
	LAC	LOW AMBIENT CONTROL
	HPC	HIGH PRESSURE CONTROL
	LPC	LOW PRESSURE CONTROL
	MS	METAL STRIP
	OFM	OUTDOOR FAN MOTOR
	RC	RUN CAPACITOR
	R	RELAY
TB	TERMINAL BLOCK	
TH	THERMOSTAT	
TDC	TIME DELAY CONTROL	
THM	THERMAL SAFETY THERMOSTAT	
TOR	THERMAL OVERLOAD RELAY	
WN	WIRE NUT	

NOTES:

1. REPLACEMENT WIRE & FUSES MUST BE SAME TYPE & SIZE AS ORIGINAL.
2. UNIT MUST BE PERMANENTLY GROUNDED & CONFORM TO N.E.C. & LOCAL CODES.
3. MAXIMUM IN RUSH VA NOT TO EXCEED 92 VA.
4. MINIMUM WIRE SIZE BASED ON 75 DEGREES C INSULATION COPPER WIRE.

WIRING INFORMATION

LINE VOLTAGE
 -FACTORY STANDARD _____
 -FACTORY OPTION - - - - -
 -FIELD INSTALLED - - - - -

LOW VOLTAGE
 -FACTORY STANDARD _____
 -FACTORY OPTION - - - - -
 -FIELD INSTALLED - - - - -

REPLACEMENT WIRE
 -MUST BE THE SAME SIZE AND TYPE OF INSULATION AS ORIGINAL (105°C MIN.)

WARNING
 -CABINET MUST BE PERMANENTLY GROUNDED AND CONFORM TO I.E.C., N.E.C., C.E.C., AND LOCAL CODES AS APPLICABLE.

WIRE COLOR CODE	
BK BLACK	O ORANGE
BR BROWN	PR PURPLE
BL BLUE	R RED
G GREEN	W WHITE
GY GRAY	Y YELLOW
WIRING SCHEMATIC	
CONDENSING UNIT	
10 TON	
208-230, 460, 575, 3PH 50 & 60 HZ	
380, 3PH, 60 HZ	
DR. BY JHB	APP. BY DATE 10-19-04
DWG. NO. 90-42663-10	REV 00

FIGURE 14
RAWL-125, -150, -180, -240 WIRING SCHEMATIC
(10, 12.5, 15 & 20 TON)

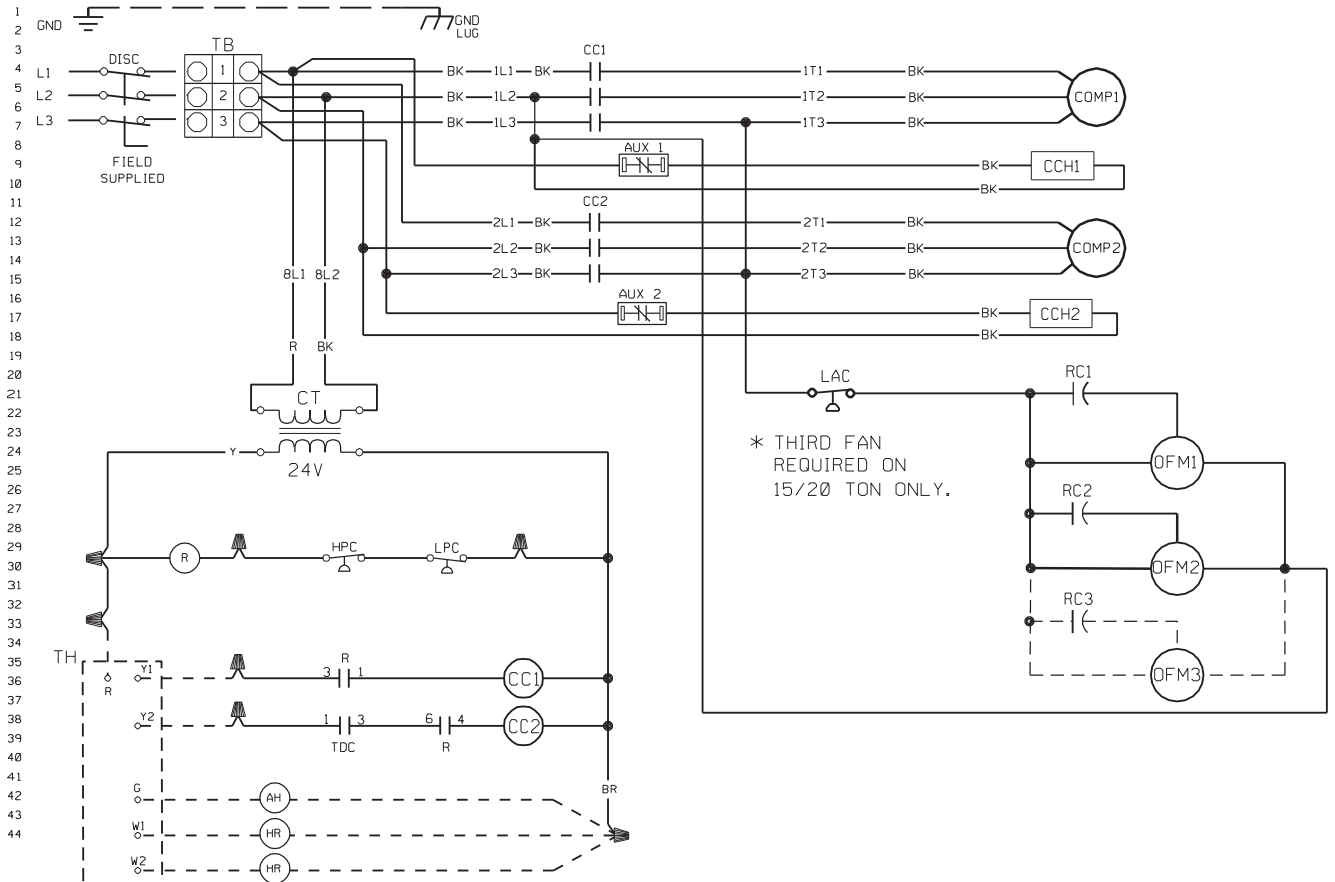

* THIRD FAN
 REQUIRED ON
 15/20 TON ONLY.

DWG. NO. 90-42663-08 REV 05	COMPONENT CODE CC COMPRESSOR CONTACTOR CCH CRANKCASE HEATER COMP COMPRESSOR CT CONTROL TRANSFORMER DISC DISCONNECT SWITCH FC FAN MOTOR CONTACTOR GND GROUND HR HEATER RELAY HPC HIGH PRESSURE CONTROL LAC LOW AMBIENT CONTROL LPC LOW PRESSURE CONTROL MS METAL STRIP OFM OUTDOOR FAN MOTOR RC RUN CAPCITOR R RELAY TB TERMINAL BLOCK TH THERMOSTAT TDC TIME DELAY CONTROL THM MOTOR SAFETY THERMOSTAT TOR THERMAL OVERLOAD RELAY WN WIRE NUT	NOTES: 1. REPLACEMENT WIRE & FUSES MUST BE SAME TYPE & SIZE AS ORIGINAL. 2. UNIT MUST BE PERMANENTLY GROUNDED & CONFORM TO N.E.C. & LOCAL CODES. 3. MAXIMUM IN RUSH VA NOT TO EXCEED 42 VA. 4. MINIMUM WIRE SIZE BASED ON 75 DEGREES C INSULATION COPPER WIRE.	WIRING INFORMATION LINE VOLTAGE -FACTORY STANDARD ————— -FACTORY OPTION - - - - - -FIELD INSTALLED - - - - - LOW VOLTAGE -FACTORY STANDARD ————— -FACTORY OPTION - - - - - -FIELD INSTALLED - - - - - REPLACEMENT WIRE -MUST BE THE SAME SIZE AND TYPE OF INSULATION AS ORIGINAL (105°C MIN.) WARNING -CABINET MUST BE PERMANENTLY GROUNDED AND CONFORM TO I.E.C., N.E.C., C.E.C., AND LOCAL CODES AS APPLICABLE.	WIRE COLOR CODE BK BLACK BR BROWN BL BLUE G GREEN GY GRAY O ORANGE PR PURPLE R RED W WHITE Y YELLOW
	WIRING SCHEMATIC CONDENSING UNIT 10, 12-1/2, 15 & 20 TON 208-230, 460, 575, 3PH 50 & 60 HZ 380, 3PH, 60 HZ			DR. BY MGR APP. BY DATE 11-14-00 DWG. NO. 90-42663-08 REV 05

