



***ColdZone***

OWNERS

INSTRUCTION MANUAL

221 South Berry Street  
Brea, CA 92621-4888

P.O. Box 1030  
Brea, CA 92622-1030

Phone: 714/529-4461 \* Fax: 714/529-8503



***ColdZone***

**ENVIRO-THERM**

**+**

**ENVIRO-COOL**

**CUSTOM PACKAGED CLOSED-LOOP SYSTEMS  
FOR ALL AMBIENT CONDITIONS**

**OWNER'S  
MANUAL**

**INSTALLATION  
OPERATION  
MAINTENANCE**

*A DIVISION OF THE HEAT TRANSFER PRODUCTS GROUP OF ARDCO. INC.*

***ColdZone***

221 S. Berry St., Brea, CA 92821-4888  
(714) 529-4461 □ FAX (714) 529-8503  
Outside California □ (800) 772-2653

**PRINTED IN U.S.A.**

© AROCO, INC 1990

TABLE OF CONTENTS

<u>TYPICAL REFRIGERATION SYSTEM</u> .....	<u>1</u>
<u>INTRODUCTION</u> .....	<u>2</u>
General Description .....	2
Condensing Unit .....	2
Refrigerant .....	2
Control Panels .....	2
Electrical Defrost .....	3
Electrical Characteristics .....	3
Standard Components .....	3
Factory Installed Accessories .....	3
U. L. Approval .....	3
W.I. Unit Coolers .....	4
<u>INSTALLATION</u> .....	<u>8</u>
Receipt and Inspection of Equipment .....	8
Lifting Instructions .....	8
Location and Ventilation .....	8
Installation Area .....	8
Roof Rail Requirements .....	8
Pitch Pocket .....	8
Electrical .....	11
Refrigeration .....	11
<u>START-UP PROCEDURE</u> .....	<u>13</u>
Condensing Units .....	13
Unit Cooler .....	13
<u>OPERATIONAL CHECK-OUT</u> .....	<u>15</u>
<u>MAINTENANCE</u> .....	<u>18</u>
Air-Cooled Condenser .....	18
Electrical and Piping Connections .....	18
Crankcase Lubrication .....	18
Unit Cooler .....	19
Heater Replacement in Low Temp Unit Cooler .....	19
<u>SERVICE DIAGNOSIS</u> .....	<u>21</u>
Condensing Units .....	21
<u>STANDARD WARRANTY</u> .....	<u>26</u>
<u>DIRECTORY OF AUTHORIZED WHOLESALERS</u>	
REPLACEMENT POLICY	

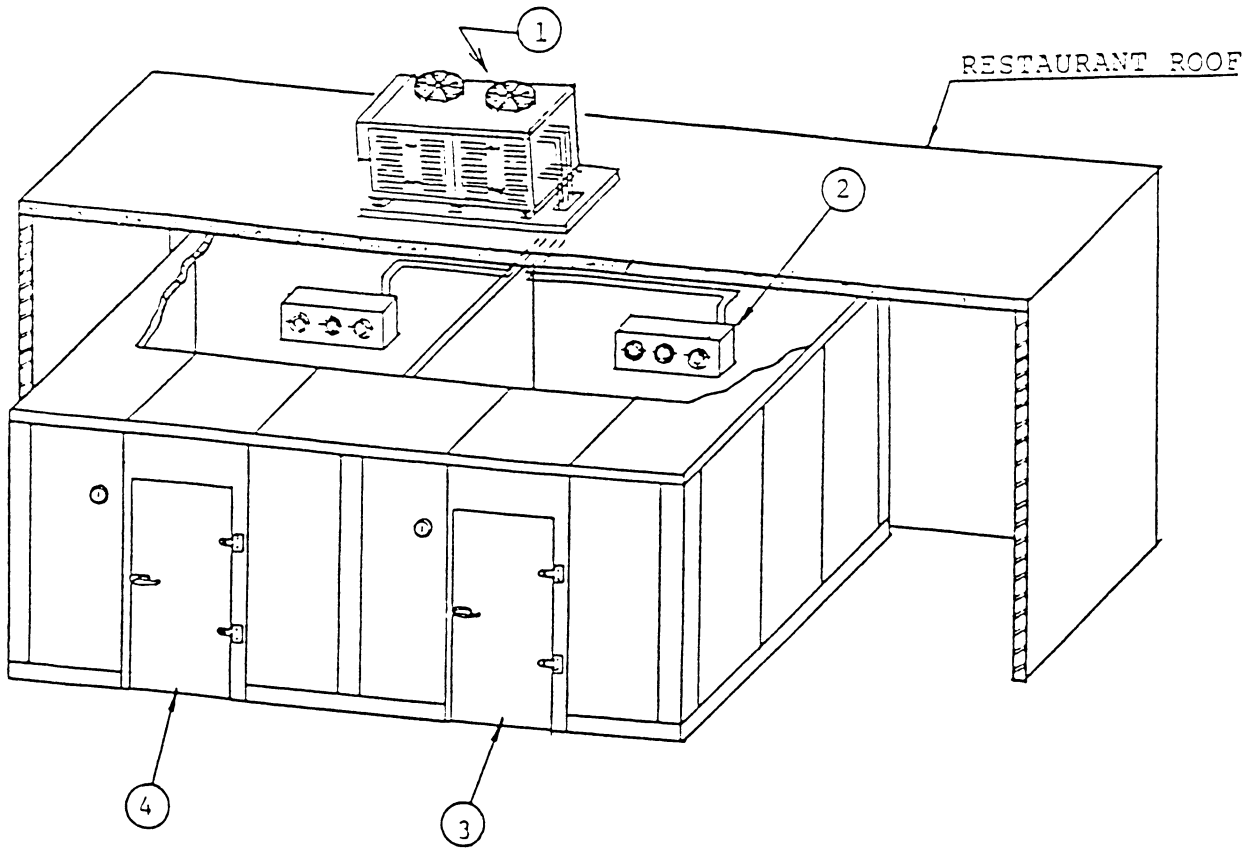

LEGEND:

- 1 - ENVIRO-THERM CONDENSING UNIT.
- 2 - UNIT COOLER.
- 3 - FREEZER WALK-IN BOX.
- 4 - COOLER WALK-IN BOX.

TYPICAL REFRIGERATION SYSTEM

## INTRODUCTION

### GENERAL DESCRIPTION (Figure 1)

The CZ + FILCO "Enviro-Therm" Outdoor Refrigeration System is designed primarily for restaurant and hotel requirements and installations where all refrigerated fixtures are to be remoted, i.e., walk-in coolers/freezers, backbars, bottle and draft beer coolers, under counter refrigerators/freezers and ice machines. This will allow the high heat producing condensing units to be placed outside the building, thus reducing indoor air conditioning requirements at a very nominal cost. Totally ore-piped, pre-wired, and weatherized for fast, low cost rigging and installation on rooftop, it is only necessary to provide main power lines to control panel and wiring for control and defrost heaters between panel and refrigeration fixtures. The system accommodates up to sixteen compressor units and three ice machine condenser in one compact cabinet thus handling all your refrigeration requirements. In addition, the unit has been carefully designed for easy installation, providing ready access for service and maintenance of all major components.

### CONDENSING UNIT

A refrigeration condensing unit is a highly sophisticated apparatus. It is installed with the anticipation that it will provide many years of trouble-free operation with minimal maintenance. Usually the length of service life realized from a particular condensing unit is directly proportional to the care with which the original installation was performed.

Cleanliness is absolutely mandatory when installing a condensing unit. Utmost care has been taken at the factory to insure that the unit is free of all contamination. The factory-applied seals must not be removed until the unit is ready for installation. All tubing, valves and fittings must be carefully inspected to insure cleanliness.

The correct electrical supply must be provided to the condensing unit control panel. The voltage at the motor-compressor terminals should be checked during start-up and unit operation under full load to insure a tolerance of plus or minus 10 percent of the nameplate rating.

The lubrication recommendations for the motor-compressor and fan motors (where applicable) must be carefully adhered to.

### REFRIGERANT

R-22 is used for the Walk-In Cooler. R-502 is used for Walk-In Freezer.

### CONTROL PANEL

Each Enviro-Therm system is provided with a prewired, weatherproof control panel for single point connection with main fused disconnect.

Control panel is designed to assure efficient unit operation and provide a pre-selected sequence of operation during the refrigeration and defrost cycles. Each control panel is equipped with an interlocked main fused disconnect, motor compressor breakers, contactors, fan motor capacitor, defrost time clock for freezer, and metal photo wiring diagram plate for service. An inside pocket is provided for engineering sheet (R-1) and installation manual.

The control panel only requires 3-wires for power supply and 4-wires for defrost heaters and unit cooler fan motors in freezer. All system circuits are labeled for easy identification.

#### ELECTRICAL DEFROST

An electric defrost heater in the freezer is field-connected to the time clock in the control panel. Defrost is initiated by a timeclock and stopped by a termination solenoid in the timeclock connected to defrost limit thermostat in the freezer coil. The timeclock is set to fail safe termination period at 45 minutes. The freezer requires four defrosts per day starting at 12:00 a.m., 6:00 a.m., 12:00 p.m., and 6:00 p.m..

#### ELECTRICAL CHARACTERISTICS

Each Enviro-Therm is equipped with 208-230 volts, 3 phase, 60 hertz power supply with a total connected load of 20 amps.

#### STANDARD COMPONENTS

Each Enviro-Therm consists of six to sixteen semi-hermetic compressors, multi-circuited condenser with heavy duty fan motors, oversized receivers, factory installed accessories, unit coolers with T-Stat, solenoid valve, TX valve and suction line P-Trap for freezer and cooler.

#### FACTORY INSTALLED ACCESSORIES

Drier, sight glass, suction and discharge vibration eliminators, head pressure, control, crankcase heater, dual pressure control, prewired control panel.

#### U.L. APPROVAL

The "Enviro-Therm" system is approved by Underwriters Laboratories and displays the U.L. Label on the Control Panel, U.L. File No. SA6629(s) under condensing and compressor units (SGYU).

## W.I. UNIT COOLERS

### 1. Freezer

A low temperature electric defrost Lo-silhouette Unit Cooler for the freezer is provided with each Enviro-Therm unit. The Unit Cooler draws air in through the coil and discharges it through the fans. For best results, the Unit Cooler should be located 18" from the back wall and blow towards the door. T-Stat, solenoid valve and TX valve are installed in the Unit Cooler at the factory. A suction line P-Trap is also installed in the Unit Cooler for better oil return.

### 2. Cooler

A medium temperature Lo-silhouette Unit Cooler for the cooler is provided with each Enviro-Therm unit. Air defrost is used for defrosting Unit Cooler. The Unit Cooler is provided with T-Stat, solenoid valve, TX valve and suction line P-Trap and is prepiped and prewired for final connections.

The C/Z+FILCO "Enviro-Therm" package refrigeration units are tested and assembled under strict quality assurance procedures. Each unit is tested and charged with nitrogen prior to shipment.

# ENVIRO - THERM

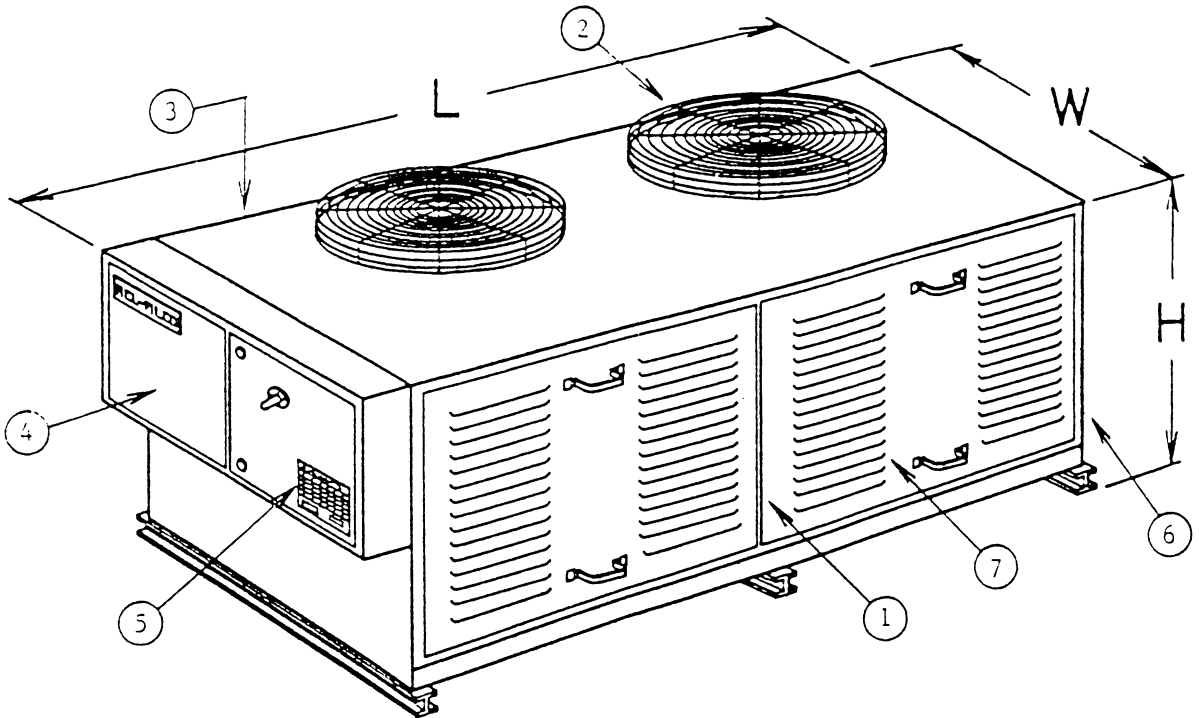

MODEL NO.	LENGTH	WIDTH	HEIGHT
ETHN-1	80	65	54
ETHN-2	104	65	54
ETHN-3	120	65	54
ETHN-4	144	65	54
ETHN-5	178	65	54
ETHN-3H	120	65	72
ETHN-4H	144	65	72
ETHN-5H	178	65	72

ITEM NO.

DESCRIPTION

1. Refrigeration Condensing Units (Inside).
2. Heavy Duty Condenser Fan Motors.
3. Multi-circuited Condenser.
4. Weatherproof Control Panel with Fused Disconnect.
5. Nameplate (Electrical) with U.L. Label.
6. Refrigeration and Electrical Lines.
7. Removable Door Panel for Service.

Figure 1. ENVIRO-THERM General Description



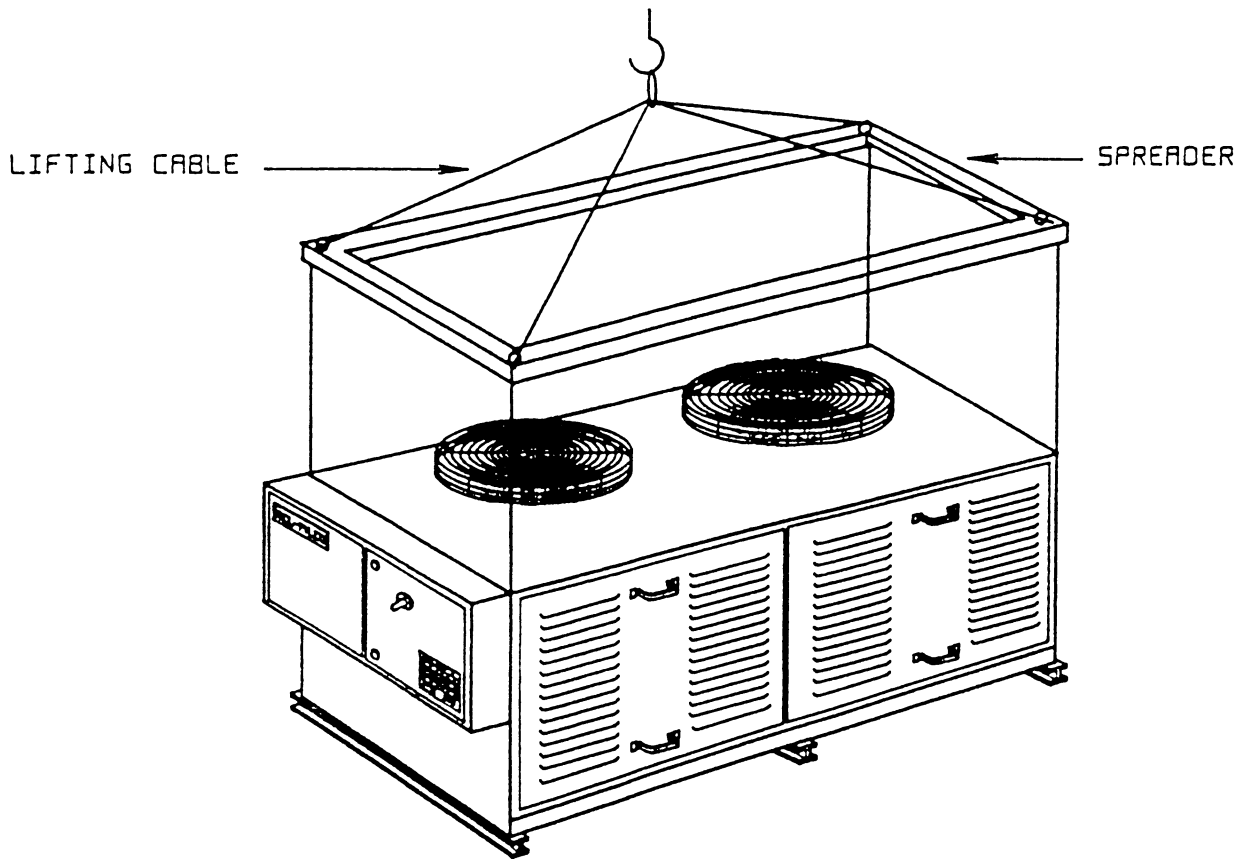

Figure 2. Lifting Instructions for ENVIRO-THERM

## INSTALLATION

### RECEIPT AND INSPECTION OF EQUIPMENT

Inspect the Enviro-Therm unit and all accessories shipped with it for any damage or shortages. Any damage or shortages should be reported immediately to the delivering carrier. Damaged material becomes the delivering carrier's responsibility and it should not be returned to the manufacturer without prior approval. Do not remove any shipping material until the unit is installed in its permanent location.

### LIFTING INSTRUCTIONS (Figure 2)

The Enviro-Therm system is a heavy piece of machinery approximately 1500 to 5000 lbs. Careful consideration of lifting procedures should be made before the unit is lifted by any means. Particularly, any cables or other load-bearing devices must not be allowed to press against piping, electrical conduit of the motor control panel. The only part of the unit designed to carry any of the lifting load is the base. Lifting loads should be distributed evenly around the base to avoid any twisting.

It is recommended that whenever the unit is lifted by a crane, the lifting space provided in the lower portion of the base frame be used as attachment points for the lifting cables as shown in Figure 2. The lifting cables should be prevented from contacting the unit by means of a spreader or similar device.

### LOCATION AND VENTILATION

The Enviro-Therm unit must be located in an area which allows easy access for installation and service of all electrical lines, refrigeration piping and any accessory equipment. The unit must be level to insure proper lubrication. A minimum of 3 feet clearance must be provided on all sides of the unit.

### INSTALLATION AREA (Figure 3)

Figure 3 illustrates the overall dimension and installation requirements.

### ROOF PLATFORM REQUIREMENTS

The roof platform requirements is shown in Figure 3. The location and installation of all equipment should be in accordance with all local code requirements. The unit can usually be placed directly upon the roof platform, since each compressor is mounted on vibration isolation. For light roof construction, vibration isolation pads can be used underneath the supporting frame.

### PITCH POCKET

A 6" x 24" pitch pocket must be provided for refrigeration lines. After lines and 7" x 4" pitch pocket for electric are installed, backfill opening with hot pitch and make sure there is no leaks.

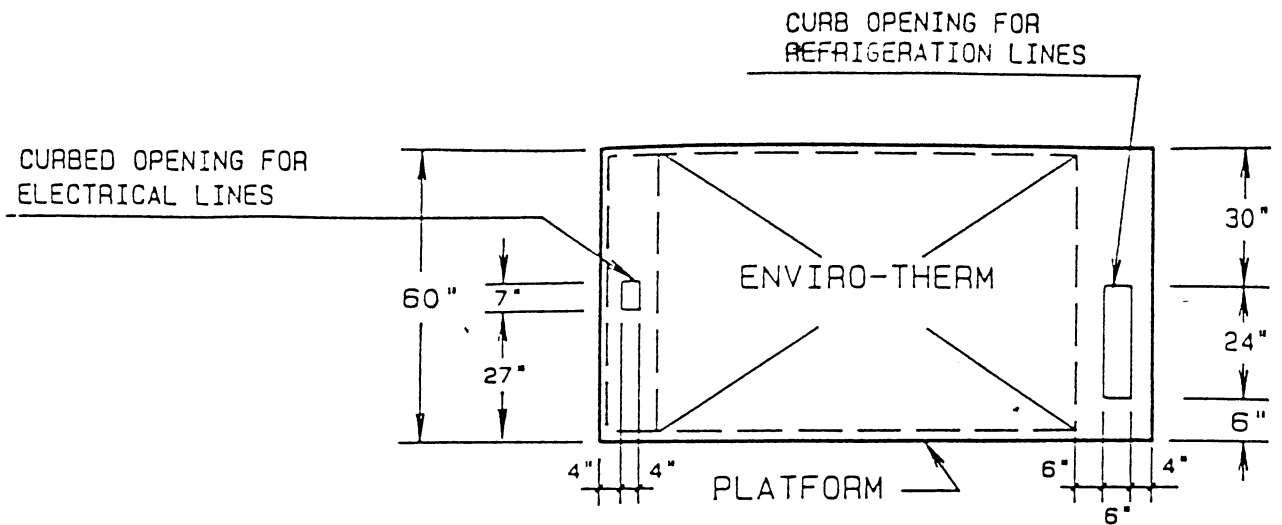

NOTES:

- 1- PLATFORM TO BE INSTALLED LEVEL.
- 2- PROVIDE SHEETMETAL HAT SECTION WITH WATER TIGHT SOLDERED JOINTS.
- 3- BACK FILL OPENING WITH HOT PITCH AFTER INSTALLATION.

## ROOF PLATFORM REQUIREMENTS

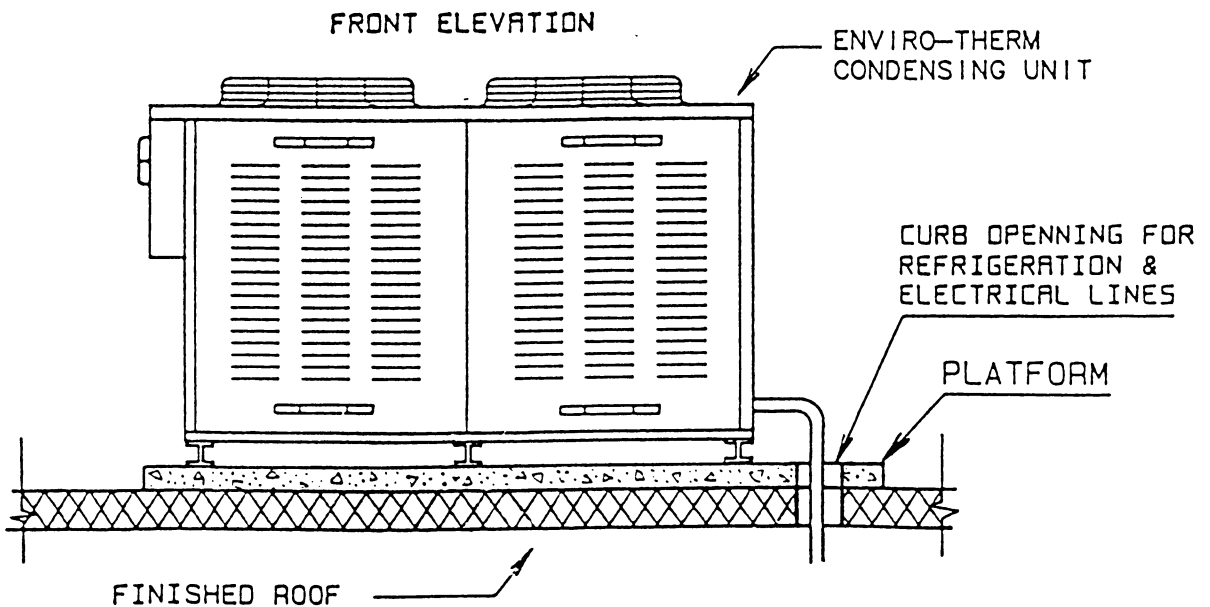

Figure 3. Installation Requirements for Enviro-Therm System



FRONT ELEVATION

ENVIRO-THERM  
CONDENSING UNIT

CURB OPENNING FOR  
REFRIGERATION &  
ELECTRICAL LINES

PLATFORM

FINISHED ROOF

P-TRAP

UNIT COOLER

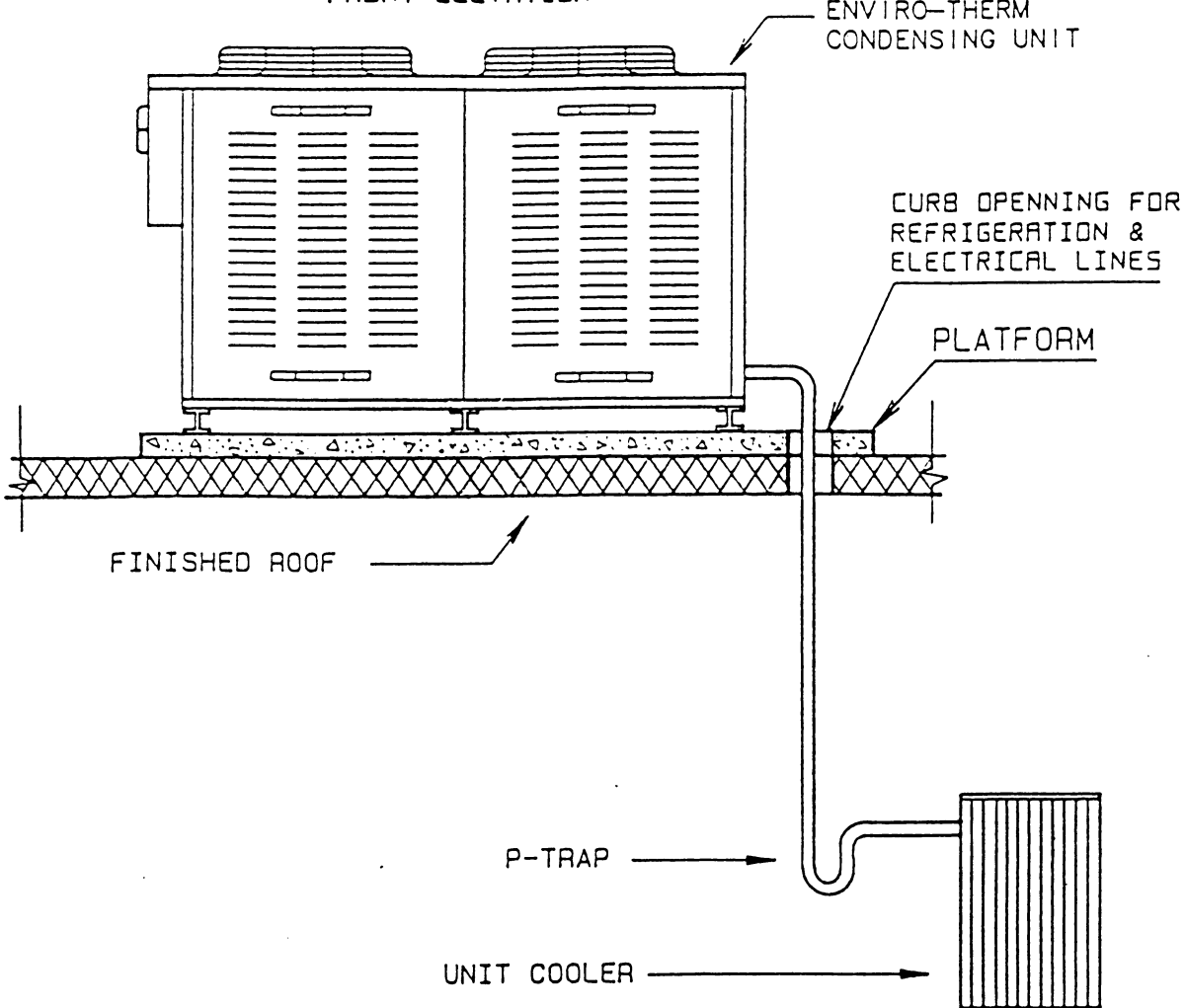

Figure 5. Piping Installation Details

## START-UP PROCEDURE

After the installation has been completed, the following points should be covered before the system is placed in operation:

### CONDENSING UNITS

1. Check electrical connections. Be sure they are all tight.
2. Observe the motor-compressor oil level before start-up. The oil level should be at or slightly above the center of the sight glass. Use only SUN1SO 3G or 3GS compressor oil.
3. Insure that the rubber grommets are installed under the motor-compressor mounting nuts and that the motor-compressor rides freely on its mounting vibration isolators.
4. Check the high and low pressure controls and all other safety controls. Adjust if necessary.
5. Check the walk-In Cooler and freezer thermostats for correct operation.
6. Suitable tags are provided to indicate the refrigerant used in the system.
7. The instruction manual, bulletins, tags, etc., attached to the unit should be placed inside the electrical control panel for future reference.
8. Observe system pressures during initial operation. Do not add oil while the system is short of refrigerant unless the oil level is dangerously low.
9. Do not leave the unit unattended until the system has reached normal operation conditions, and the oil charge has been properly adjusted to maintain the oil level at the center of the sight glass.

-CAUTION-

Do not overcharge with oil.

### UNIT COOLER

#### A. Before Start-Up

1. Make sure system is wired correctly. (Figure 4)
2. Check to make sure all electrical terminals are tight.
3. Make sure fan set screws are tight.
4. Make sure unit is mounted securely using all the hangers and is as level as possible.

5. Make sure the drain connection is tightened to the drain line securely.
6. Pour water into the drain pan to check for complete drainage of drain pan and drain line.

#### After Start-Up

1. On initial start-up of freezer unit cooler, the fans will not start until the coil temperature reaches about 25°F. Also it is normal for the fans to cycle a few times until the room temperature is pulled down.
2. Check the expansion valve superheat setting. It is important that the valve is set properly for efficient operation and even frost formation.
3. Make sure the drain line heater is working properly.
4. Heavy moisture loads are usually encountered when starting a system for the first time. This will cause a rapid frost build-up on the unit. During the initial pulldown we suggest that the frost build-up be watched and that the unit be defrosted manually as required.
5. Observe the system as it goes through the first defrost cycle to make sure that the timer, defrost heaters, termination thermostat and other system components function properly.

OPERATIONAL CHECK-OUT

Only after the system has operated for at least two hours at normal operating conditions without any indication of malfunction should it be allowed to operate overnight on automatic controls. A thorough recheck of the entire system operation should be made as follows:

1. Check the motor-compressor head and suction pressures. If the pressures are not within the system design limits, determine why and take corrective action.
2. Check the liquid line sight glass and expansion valve operation. If there are indications that more refrigerant is required, leak test all connections and system components and repair any leak before adding refrigerant.
3. Observe the oil level in the motor-compressor crankcase sight glass and add oil as necessary to bring the level to the center of the sight glass.
4. Thermostatic expansion valves must be checked for proper superheat settings. Feeler bulbs must be in positive thermal contact with the suction line. Valves with high superheat settings produce little refrigeration and poor oil return. Too little superheat causes low refrigeration capacity and promotes liquid slugging and compressor bearing washout. Liquid refrigerant must be prevented from reaching the crankcase. If proper control cannot be achieved with the system in normal operation, a suction accumulator must be installed in the suction line just ahead of the motor-compressor to prevent liquid refrigerant from reaching the motor-compressor.
5. Using suitable instruments, carefully check line voltage and amperage at the compressor terminals. Voltage must be plus or minus 10 percent of that indicated on the compressor nameplate. If too high or too low voltage is indicated, notify the power company. The current normally should not exceed 120 percent of the nameplate rating. If amperage draw is excessive, immediately determine the cause and take corrective action. On three phase, motor-compressor, check to see that a balanced load is drawn by each phase.
6. Check fan motor on air-cooled condensers and in walk-in evaporator coils for correct rotation. Fan motor mounts should be carefully checked for tightness and proper alignment.
7. High pressure controls on condensing units should be set to cut out as follows:

R-12	R-22 and R-502
223 psig	350 psig

The cut-out point of these controls should be checked by stopping the condenser fan and simultaneously monitoring the head pressure with an accurate gauge.



8. Re-check all safety controls and operating controls for proper operation and adjust if necessary.
9. Check the defrost timeclock for initiation, termination and length of defrost period as described below.

The standard defrost timer furnished by ACL-FILCO provides frequency control including a fail-safe feature that automatically terminates defrost after a set time if the termination thermostat fails to function properly. The standard timer is furnished with a 240 volt clock motor and has a contact rating of 40 amps at 240 volts. Figure 6 shows the timer dial.

- a. To set the number of defrosts every 24 hours, screw a pin into the outer dial at each desired time of defrost.
- b. To set the time of day, grasp the center knob and rotate counterclockwise until the correct time of day on the outer dial is lined up with the pointer. Do not attempt to set the timer by grasping and turning the outer dial.
- c. To set the fail-safe time, push down the pointer on the inner dial and adjust it to the desired time in minutes.

The timer should initially be set for 4 defrost cycles per day. However, each installation should be checked so the system operates efficiently with a minimum number of defrost cycles. The fail-safe setting should not normally exceed 45 minutes because of danger of overheating the unit if the defrost cycle is prolonged too long.

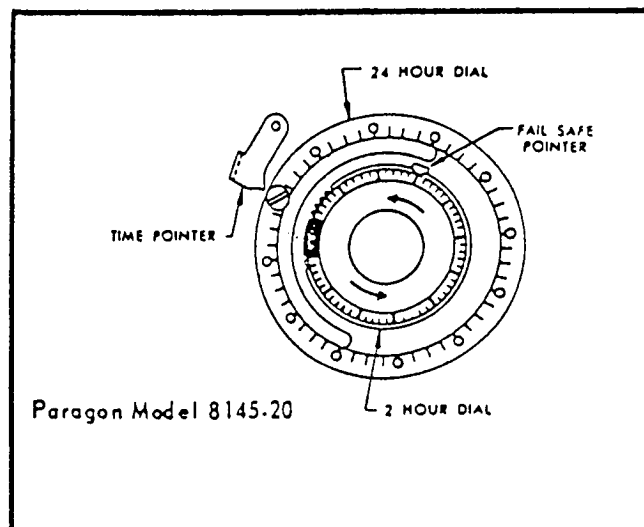

Figure 6. Timer dial

10. Dual pressure control setting on condensing units should be set to cut in and cut out as follows:

Fixture Description	High	Low	
	Cut Out psig	In psig	Out psig
Walk-In Freezer	350	26	15
Walk-In Cooler	225	28	17

## MAINTENANCE

### AIR-COOLED CONDENSER

Air-cooled condenser should be cleaned with a brush and vacuum cleaner every four to six months to remove all accumulations of dust, leaves and other debris. Where air-cooled condensers must operate in usually dusty locations, cleaning should be scheduled as often as conditions dictate.

### WARNING

Be sure that the main disconnect switch is in the OFF position before any cleaning of the condensers is attempted.

### ELECTRICAL AND PIPING CONNECTIONS

All electrical connections should be periodically checked to be sure they are tight. Loose connections contribute to low voltage conditions which can cause motor failure.

Refrigerant connections should be inspected to insure that they have not loosened. Whenever it is necessary to add refrigerant, a careful leak check of all refrigerant connections should be made.

### CRANKCASE LUBRICATION

As indicated under the operational check-out procedures, the oil level in the motor-compressor crankcase should be at the center of the sight glass at all times. If the oil level is low, more oil should be added to bring the level up to center of the sight glass and the cause of oil migration corrected. Check the expansion valve adjustment and the size of risers and traps.

The quality of the compressor oil can, however, be checked rather easily by using an oil sampler. Visual examination of the compressor oil can disclose the condition of the system. Acid test is highly recommended to measure the extent of contamination in a system. Dirty, discolored oil probably indicates one of the following:

1. Contaminants such as moisture, air, etc., trapped in the system.
2. Excessive system pressure drop or improper control settings allows motor-compressors to operate at a dangerously low suction pressure. This may cause motor compressor overheating and oil discolorization.

If this situation occurs and oil discoloration is not too dark, the installation of a new liquid line filter-drier may be enough to remove contamination and clear the oil. If the discoloration is severe, the oil should be replaced and a new liquid line filter-drier installed as many times as necessary to eliminate the contamination. After the oil is replaced, the system controls should be readjusted.

#### UNIT COOLER

Unit cooler should be checked at least once a month for proper defrosting to maintain amount and pattern of frosting. It is dependent on the temperature of the room, the type of product being stored, how often new product is brought into the room and the percentage of time the door to the room is open. Also, if the coil is not defrosting completely, check for faulty defrost heaters.

Under normal usage, maintenance should cover the following items at least once every six months.

1. Tighten all electrical connections.
2. Tighten fan set screws.
3. Clean the coil surface.
4. Check the operation of the control system.
5. Clean the drain pan and check for proper drainage.
6. Check the drain line heaters.

#### HEATER REPLACEMENT IN LOW TEMP UNIT COOLER

1. Make sure the electrical power to the heaters is turned off.
2. Disconnect heater leads on both ends of the heater to be removed.
3. Remove the sheetmetal screws holding the heater retainer to the header plate on the electrical connection end of the unit.
4. Pull the heater(s) to be replaced out of the tube holes in the coil. It is necessary to lower the drain pan to remove the bottom coil heater.
5. Replacement coil heaters are received coiled in a two foot diameter. Before inserting the heater in the coil, uncoil about one foot of the straight end to make it easier to insert the heater into the tube hole.

6. Insert the end of the heater into the tube hole and uncoil it while pushing it through the coil.
7. Attach tube clamp and retaining bracket to new heater just before rubber boot. Push heater in until bracket meets the header plate. Fasten bracket to the header plate to prevent heater "creep".
8. Reconnect the heater leads as shown on the wiring diagram.

SERVICE DIAGNOSIS - CONDENSING UNITS

SYMPTOM	CAUSE	REMEDY
A. Compressor does not run.	<ol style="list-style-type: none"> <li>1. Motor line open.</li> <li>2. Fuse blown.</li> <li>3. Tripped overload.</li> <li>4. Control contacts dirty or jammed in open position.</li> <li>5. Piston seized.</li> <li>6. Frozen compressor or motor bearings.</li> <li>7. Control in off position because of cold location.</li> <li>8. Defective starting Component (single phase compressor only).</li> </ol>	<ol style="list-style-type: none"> <li>1. Close start or disconnect switch.</li> <li>2. Replace fuse.</li> <li>3. See part C.</li> <li>4. Repair or replace.</li> <li>5. Remove motor compressor head. Look for broken valve and jammed parts.</li> <li>6. Repair or replace.</li> <li>7. Use thermostatic control or move control to warmer location.</li> <li>8. Locate and replace.</li> </ol>
B. Unit short cycles.	<ol style="list-style-type: none"> <li>1. Control differential set too closely.</li> <li>2. Discharge valve leaking.</li> <li>3. Motor-compressor overload .</li> <li>4. Refrigerant shortage.</li> <li>5. Refrigerant overcharge.</li> <li>6. Cycling on high pressure cut-out.</li> </ol>	<ol style="list-style-type: none"> <li>1. Widen differential.</li> <li>2. Correct condition.</li> <li>3. Check for high head pressure, tight bearings, seized pistons, clogged air cooled condenser.</li> <li>4. Repair leak and recharge .</li> <li>5. Purge.</li> <li>6. Check water supply, dirty condenser or defective fan.</li> </ol>
C. Compressor will not start - hums intermittently (cycling on overload).	<ol style="list-style-type: none"> <li>1. Improperly wired.</li> </ol>	<ol style="list-style-type: none"> <li>1. Check wiring against diagram.</li> </ol>

SERVICE DIAGNOSIS - CONDENSING UNITS (Cont.)

SYMPTOM	CAUSE	REMEDY
(Cont.)		
C. Compressor will not start- hums intermittently (cycling on overload).	2. Low line voltage.	2. Check main line voltage and determine location of voltage drops.
	3. Relay contacts not closing.	3. Check by operating manually. Replace relay if defective.
	4. Open circuit in starting winding.	4. Check stator leads. If leads are OK, replace stator.
	5. Stator winding grounded.	5. Check stator leads. If leads are OK, replace stator.
	6. High discharge pressure.	6. Eliminate cause of excessive pressure. Make sure discharge shut-off valve is open.
	7. Tight compressor.	7. Check oil level; correct binding.
	D. Unit operates long or continuously.	1. Refrigerant shortage.
2. Control contacts sticking in closed position.		2. Clean points or replace control.
3. Dirty condenser.		3. Clean condenser.
4. Air in system.		4. Purge.
5. Compressor inefficient,		5. Check valves and pistons.
6. Improper wiring.		6. Check wiring and correct if necessary.
E. Fixture temperature too high.	1. Refrigerant shortage.	1. Repair leak and re charge.
	2. Control set too high.	2. Reset control.
	3. Control wiring loose.	3. Check wiring to control.
	4. Expansion valve or strainer plugged.	4. Clean or replace.
	5. Compressor inefficient.	5. Check valves and pistons.
	6. Expansion valve set too high.	6. Lower settings.

SERVICE DIAGNOSIS - CONDENSING UNITS (Cont.)

SYMPTOM	CAUSE	REMEDY
(Cont.)		
E. Fixture temperature too high.	<ul style="list-style-type: none"> <li>7. Iced or dirty coil.</li> <li>8. Unit too small.</li> <li>9. Clogged or small gas lines.</li> <li>10. Oil logged system.</li> </ul>	<ul style="list-style-type: none"> <li>7. Defrost or clean.</li> <li>8. Add unit or replace.</li> <li>9. Clear clogging or increase line size.</li> <li>10. Remove excess oil, check refrigerant charge.</li> </ul>
F. Head pressure too high.	<ul style="list-style-type: none"> <li>1. Refrigerant overcharge,</li> <li>2. Air in system.</li> <li>3. Dirty air-cooled condenser .</li> <li>4. Insufficient water supply.</li> <li>5. Recirculating cooling air.</li> <li>6. High Side restriction.</li> <li>7. Head pressure control valve set wrong.</li> </ul>	<ul style="list-style-type: none"> <li>1. Purge.</li> <li>2. Purge.</li> <li>3. Clean area around air-cooled condenser and inspect for air borne dirt source.</li> <li>4. Check water valves and inspect cooler.</li> <li>5. Seal off unit from other machines and provide intake isolated from air outlet.</li> <li>6. Remove blockage.</li> <li>7. Readjust.</li> </ul>
G. Head Pressure too low	<ul style="list-style-type: none"> <li>1. Refrigerant shortage.</li> <li>2. Compressor suction or discharge valves in efficient .</li> <li>3. Cold ambient or cold water.</li> <li>4. Head pressure control valve set wrong or no head pressure valve installed.</li> </ul>	<ul style="list-style-type: none"> <li>1. Repair leak and re charge.</li> <li>2. Clean or replace leaky valve plates.</li> <li>3. No remedy, as efficiency is generally increased. However, if condensing temperature is below 85°F expansion valve will not be able to feed properly and some form of head pressure control must be provided.</li> <li>4. Readjust or install a head pressure control valve.</li> </ul>



SERVICE DIAGNOSIS - CONDENSING UNITS (Cont.)

SYMPTOM	CAUSE	REMEDY
H. Noisy unit.	1 . Insufficient compressor oil.	1. Add oil to proper level.
	2. Tubing rattle.	2. Bend tubes away from contact.
	3. Mounting loose.	3. Tighten.
	4. Oil slugging or refrigerant flooding back.	4. Adjust oil level or refrigerant charge. Check expansion valve for leak or oversized orifice.
	5. Unbalanced fan or defective fan motor.	5. Replace bent or broken fan blades. Check motor bearings.
I. Compressor loses oil.	1. Short of refrigerant.	1. Repair leak and re charge.
	2. Gas-oil ratio low.	2. Add 1 pt. oil for each 10 lbs. of refrigerant added to factory charge.
	3. Plugged expansion valve or strainer.	3. Clean or replace.
	4. Oil trapping in lines	4. Drain tubing toward compressor.
	5. Short cycling.	5. Refer to Part B.
	6. Superheat too high at compressor suction.	6. Change location of expansion valve bulb or adjust valve to return wet gas to compressor.
J. Frosted or sweating suction line.	1. Expansion valve admitting excess refrigerant.	1. Adjust: expansion valve.
K. Hot liquid line.	1. Shortage of refrigerant .	1. Repair leak and re charge.
	2. Expansion valve open too wide.	2. Adjust expansion valve.

SERVICE DIAGNOSIS - CONDENSING UNITS (Cont.)

SYMPTOM	CAUSE	REMEDY
L. Frosted liquid line.	1. Receiver shut-off valve partially closed or restricted. 2. Clogged dehydrator or strainer.	1. Open valve or remove. 2. Replace clogged part.
M. Unit on vacuum.	1. Ice plugging expansion valve orifice. 2. Plugged expansion valve.	1. Apply hot wet cloth to expansion valve. If suction pressure now increases, there is moisture in the system and a dryer should be installed in the line. 2. Clean strainer or replace expansion valve.



# ***ColdZone***

## **LIMITED WARRANTY**

*ColdZone* warrants, to the original purchaser, each product to be free from defects in material and workmanship if installed and used in compliance with *ColdZone* preparatory start-up procedure. The limited warranty is effective for period of twelve (12) months from the date of start-up and is not to exceed fifteen (15) months from the date of seller's invoice. Under the terms of this warranty, *ColdZone* will, repair or replace, at seller's option, any part(s) which, when returned in sealed containers, tagged as to serial and model numbers, with transportation charges prepaid to the factory or service location designated by *ColdZone* proves to be defective.

***ColdZone* assumes NO responsibility for incidental or consequential damages, including, but not limited to, refrigerant, labor, taxes, food loss, service charges, lost profits, injury to person(s) or property, travel expenses, acts of God, etc...**

This warranty does not apply to equipment that has been damaged in transit, altered, abused, or where *ColdZone* service and installation requirements are not met. Replaced parts warranty expires on original product warranty expiration.

As each compressor sold by *ColdZone* is warranted by the compressor manufacturer, replacement during the first year of operation must be made through an authorized wholesaler. *ColdZone* extends the manufacturer's warranties to its customers.

*ColdZone* includes a sequentially numbered preparation/start-up procedure in each unit shipped. This preparation/start-up procedure must be completed and returned to "Attn.: Service Manager," via certified mail to activate the limited warranty.

*ColdZone* neither assumes nor authorizes any person(s) to assume for seller any obligation or warranty other than that which is stated in this warranty.

This warranty is valid only after all financial obligations to *ColdZone* have been paid.

*ColdZone* is solely responsible for this warranty and makes no other warranty, either expressed or implied. All implied warranties or merchantability and fitness for a particular purpose which exceed *ColdZone* obligations are hereby disclaimed and excluded from this warranty.

*ColdZone* must be notified of any claim against this warranty within 120 days of the occurrence, with the stipulation that this notification is not made more than thirty (30) days after the expiration of this warranty. Claims made beyond these time frames will not be honored.

P.O. Box 1030 • Brea, CA 92822-1030 • 221 South Berry Street • Brea, CA 92821  
Phone: 714/529-4461 • 800/772-2653 • Fax: 714/529-8503



# ***ColdZone***

## **ADDITIONAL 4-YEAR WARRANTY of MOTOR-COMPRESSOR ASSEMBLY**

In addition to the standard warranty, for further consideration, the Company will extend the warranty on the motor compressors for an additional four years following the expiration of the standard warranty.

The motor compressor assembly is comprised of the stator, rotor, eccentric shaft, eccentric rod, wrist pin, suction valve, discharge valve, and the housing in which these parts are enclosed, and includes capacity reduction unloaders and overload protection modules as supplied with the original motor-compressor. The obligation of the Company under the extended warranty is to provide a replacement motor-compressor, or reimbursement for one obtained as directed, less any credit allowed for return of the original, motor-compressor.

The extended 4-year warranty applies only to the motor-compressor as specified above, and does not cover any other portion of the equipment.

P.O. Box 1030 • Brea, CA 92822-1030 • 221 South Berry Street • Brea, CA 92821  
Phone: 714/529-4461 • 800/772-2653 • Fax: 714/529-8503