

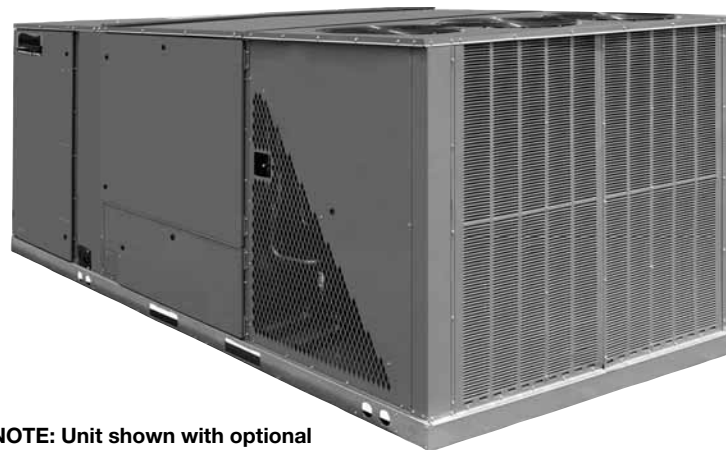

H₂AC™ Rooftop Unit featuring eSync™ Integration Technology



NOTE: Unit shown with optional
louvered coil protection guard.

RLHL-D Series

- With ClearControl™
- Nominal Size: 15 Ton [52.8 kW]
- ASHRAE 90.1-2010 Compliant Models



RUUD HIGH EFFICIENCY TANKLESS OR COMMERCIAL TANK RECOMMENDED FOR THE GREATEST ENERGY SAVINGS POTENTIAL.

Ruud Commercial Water Storage Tank:

- 2" fittings
- 80 or 115 Gallon Capacities available

TABLE OF CONTENTS

Unit Features & Benefits	3-9
Model Number Identification	10
Options	11
Selection Procedure	12
<i>eSync Integration Technology</i> [™] Cost Savings Example	13
<i>eSync Integration Technology</i> [™] Typical Piping Example	14
<i>eSync Integration Technology</i> [™] Typical Piping Maximum Length	15
<i>eSync Integration Technology</i> [™] Piping Equivalent Length	16
General Data	
RLHL- Series	17
General Data Notes.....	18
Gross Systems Performance Data	
RLHL- Series	19-20
Airflow Performance	
RLHL- Series	21
Electrical Data	
RLHL- Series	22
Electric Heater Kits	23
Dimensional Data	24-26
Accessories	27-39
Mechanical Specifications	40-45
Wiring Diagrams	46-49
Limited Warranty	50



RLHL-D STANDARD FEATURES INCLUDE:

- R-410A HFC refrigerant
- Complete factory charged, wired and run tested
- Scroll compressors with internal line break overload and high-pressure protection
- Dual Independent compressors for two-stage operation
- Downflow only
- TXV refrigerant metering system
- High Pressure and Low Pressure/Loss of charge protection standard on all models
- Solid Core liquid line filter drier
- Single slab, single pass designed evaporator and condenser coils facilitate easy cleaning for maintained high efficiencies
- Cooling operation up to 125 degree F ambient
- Foil faced insulation encapsulated throughout entire unit minimizes airborne fibers from the air stream
- Hinged major access door with heavy-duty gasketing, 1/4 turn latches and door retainers
- Slide Out Indoor fan assembly for added service convenience
- Powder Paint Finish meets ASTM B117 steel coated on each side for maximum protection G90 galvanized
- One piece base pan with drawn supply and return opening for superior water management
- Forkable base rails for easy handling and lifting
- Single point electrical connections
- Internally sloped slide out condensate pan conforms to ASHRAE 62 standards
- High performance belt drive motor with variable pitch pulleys and quick adjust belt system
- Permanently lubricated evaporator and condenser motors
- Condenser motors are internally protected, totally enclosed with shaft down design
- 2 inch filter standard with slide out design
- 24 volt control system with resettable circuit breakers
- Colored and labeled wiring
- Copper tube/Aluminum Fin indoor coils with all aluminum MicroChannel condenser coil
- Supplemental electric heat provides 100% efficient heating.
- Factory Installed ClearControl™, a Direct Digital Control (DDC) and sensors which can connect to LonWorks™ or BACnet® BAS systems for remote monitoring and control
- Pressure sensors provide refrigerant pressures, superheat, and subcooling on the ClearControl™ display
- H₂AC Package Unit featuring eSync Integration Technology includes water circulation pump, refrigerant-to-water heat exchanger, and eSync Integration Technology control board for heat recovery during air conditioning mode to preheat potable water.

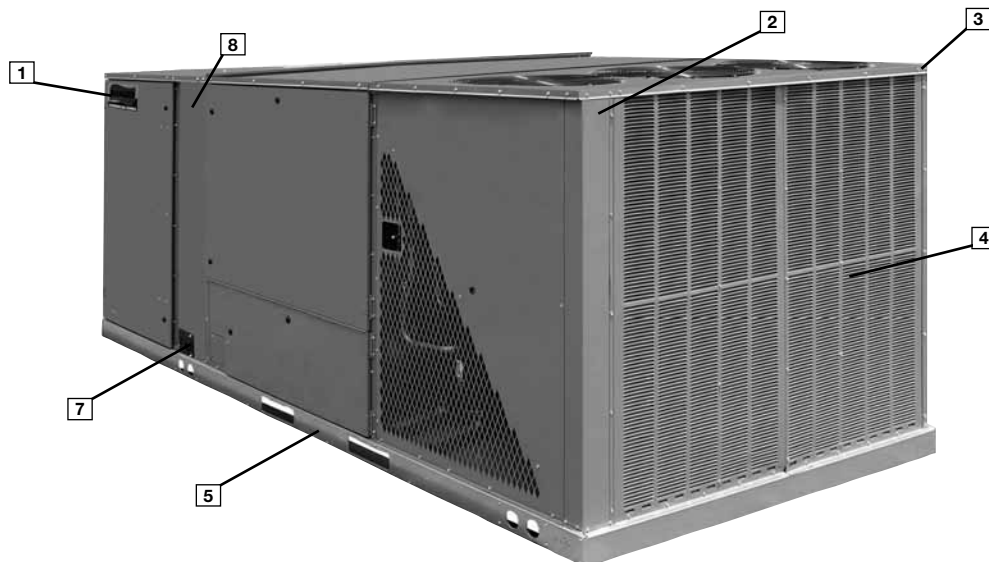

Ruud Package equipment is designed from the ground up with the latest features and benefits required to compete in today's market. The clean design stands alone in the industry and is a testament to the quality, reliability, ease of installation and serviceability that goes into each unit. Outwardly, the large Ruud Commercial Series™ label (1) identifies the brand to the customer.

The sheet-metal cabinet (2) uses nothing less than 18-gauge material for structural components with an underlying coat of G90. To ensure the leak-proof integrity of these units, the design utilizes a top with a 1/8" drip lip (3), gasket-protected panels and screws. The Ruud hail guard (4) (optional) is its trademark, and sets the standard for coil protection in the industry. Every Ruud package unit uses the toughest finish in the industry, using electro deposition baked-on enamel tested to withstand a rigorous 1000-hour salt spray test, per ASTM B117.

Anything built to last must start with the right foundation. In this case, the foundation is 14-gauge, commercial-grade, full-perimeter base rails (5), which integrate fork slots and rigging holes to save set-up time on the job site. The base pan is stamped, which forms a 1-1/8" flange around the supply and return opening and has eliminated the worry of water entering the conditioned space (6). The drainpan (7) is made of material that resists the growth of harmful bacteria and is sloped for the latest IAQ benefits. Furthermore, the drain pan slides out for easy cleaning. The insulation has been placed on the underside of the basepan, removing areas that would allow for potential moisture accumulation, which can facilitate growth of harmful bacteria. All insulation is secured with both adhesive and mechanical fasteners, and all edges are hidden.

During development, each unit was tested to U.L. 1995, ANSI 21.47, AHRI 340/360 and other Ruud-required reliability tests. Ruud adheres to stringent ISO 9002 quality procedures, and each unit bears the U.L. and AHRI certification labels located on the unit nameplate (8). Contractors can rest assured that when a Ruud package unit arrives at the job, it is ready to go with a factory refrigerant charge and quality checks.

Access is granted with 1/4 turn fasteners and hinged access panels. Access to all major compartments is from the front of the unit, including the filter and electrical compartment, blower compartment, furnace section, and outdoor section. Each panel is permanently embossed with the compartment name (control/filter access, blower access and electric heat access).

Electrical and filter compartment access is through a large hinged access panel. The unit charging chart is located on the inside of the electrical and filter compartment door. Electrical wiring diagrams are found on the control box cover, which allows contractors to move them to more readable locations. To the right of the control box the model and serial number can be found. Having this information on the inside will assure model identification for the life of the product. The production line quality test assurance label is also placed in this location (9). The two-inch throwaway filters (10) are on a tracked system for easy removal and replacement.

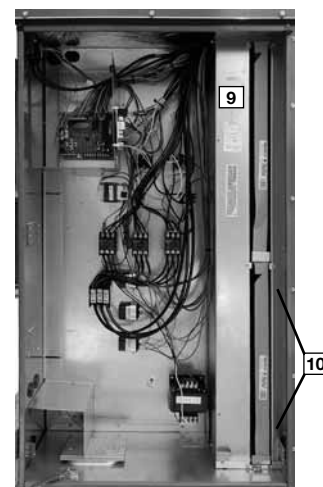
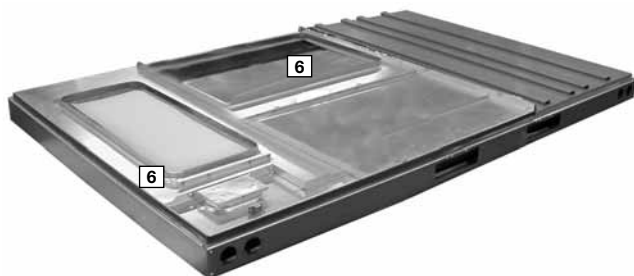

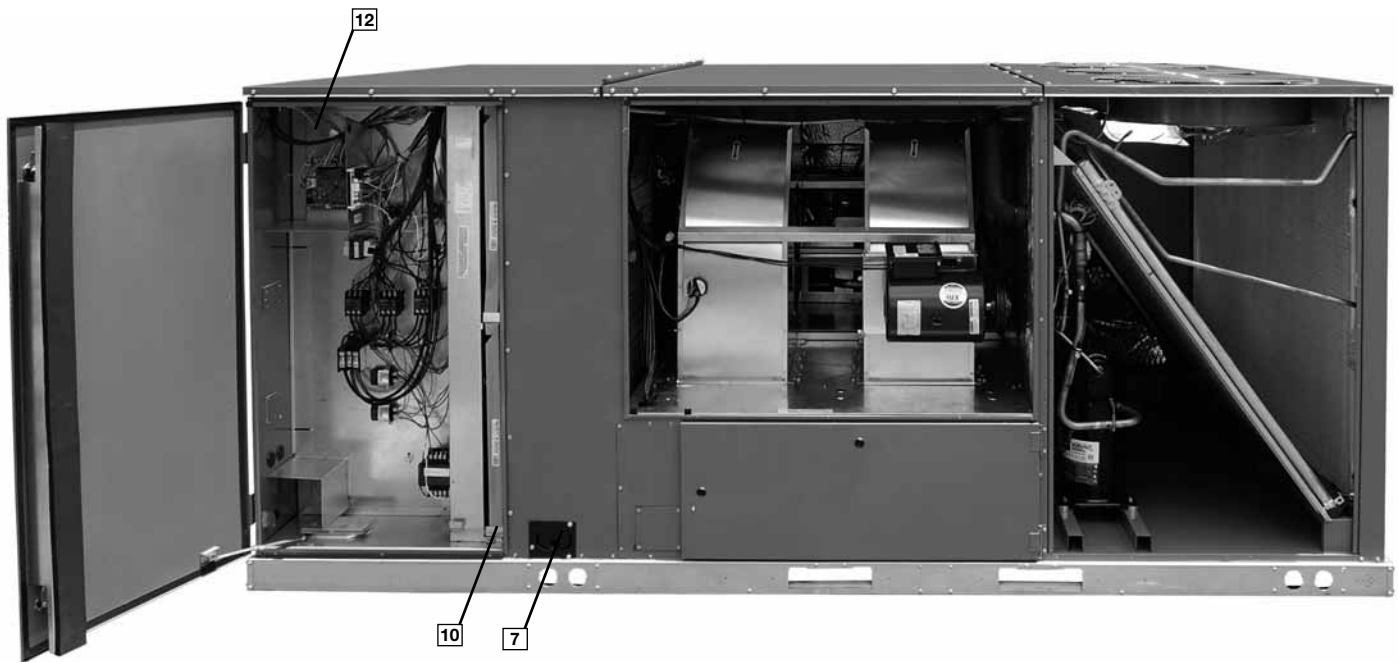

Inside the control box (11), each electrical component is clearly identified with a label that matches the component to the wiring diagram for ease of troubleshooting. All wiring is numbered on each end of the termination and color-coded to match the wiring diagram. The integrated furnace control, used to control furnace operation, incorporates a flashing LED troubleshooting device. Flash codes are clearly outlined on the unit wiring diagram. The control transformer has a low voltage circuit breaker that trips if a low voltage electrical short occurs. There is a blower contactor, and contactor for each compressor.



As part of the ClearControl™ system which allows real time monitoring and communication between rooftop units, the RLHL-D Package Air Conditioner has a Rooftop Unit Controller (RTU-C) factory mounted and wired in the control panel. The RTU-C is a solid-state microprocessor-based control board that provides flexible control and extensive diagnostics for all unit functions. The RTU-C through Proportional/Integral control algorithms perform specific unit functions that govern unit operation in response to: zone conditions, system temperatures, system pressures, ambient conditions and electrical inputs. The RTU-C features a 16 x 2 character LCD display and a five-button keypad for local configuration and direct diagnosis of the system (12). New features include a clogged filter switch (CFS), fan proving switch (FPS), return air temperature sensor (RAT), discharge air temperature sensor (DAT) and outdoor air temperature sensor (OAT). Freeze sensors (FS) are used in place of freezestats to allow measurement of refrigerant suction line

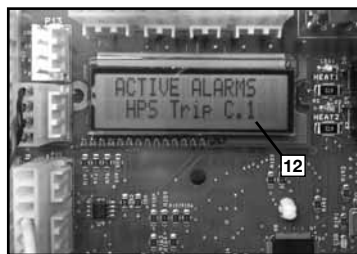

temperatures. The RLHL-D Package Air Conditioner with the RTU-C is specifically designed to be applied in four distinct applications:

The RLHL-D is compatible with a third party building management system that supports the BACnet Application Specific Controller device profile, with the use of a field installed BACnet Communication Module. The BACnet Communication Module plugs onto the unit RTU-C controller and allows communication between the RTU-C and the BACnet MSTP network. A zone sensor, a BACnet network zone sensor, a BACnet thermostat or DDC controller may be used to send the zone temperature or thermostat demands to the RTU-C. The BACnet Communication Module is compatible with MSTP EIA-485 daisy chain networks communicating at 38.4 bps. It is compatible with twisted pair, shielded cables.

The RLHL-D is compatible with a third party building management system that supports the LonMark Space Comfort Controller (SCC) functional profile or LonMark Discharge Air Controller (DAC) functional profile. This is accomplished with a field installed LonMark communication module. The LonMark Communication Module plugs onto the RTU-C controller and allows communication between the RTU-C and a LonWorks Network. A zone sensor, a LonTalk network zone sensor, or a LonTalk thermostat or DDC controller may be used to send the zone temperature or thermostat demands to the RTU-C. The LonMark Communication Module utilizes an FTT-10A free topology transceiver communicating at 78.8 kbps. It is compatible with Echelon qualified twisted pair cable, Belden 8471 or NEMA Level 4 cables. The Module can communicate up to 1640 ft. with no repeater. The LonWorks limit of 64 nodes per segment applies to this device.

The RLHL-D is compatible with a programmable 24 volt thermostat. Connections are made via conventional thermostat screw terminals. Extensive unit status and diagnostics are displayed on the LCD screen of the RTU-C.

The RLHL-D is compatible with a zone sensor and mechanical or solid state time clock connected to the RTU-C. Extensive unit status and diagnostics are displayed on the LCD screen of the RTU-C.

A factory or field installed Comfort Alert® module is available for power phase-monitoring protection and additional compressor diagnostics. The alarms can be displayed on the RTU-C display, through the (BAS) network, or connected to the “L-Terminal” of a thermostat for notification.

The RLHL-D has a special *eSync Integration Technology* (potable water heating) control board (13) connected to the Rooftop Unit Controller (RTU-C) that allows potable water heat recovery during air conditioning mode. The *eSync Integration Technology* control board adds pressure sensors to provide refrigerant pressures, superheat, and subcooling on the RTU-C LCD display.

Whenever a call for cooling is present, the Ruud H₂AC Rooftop Unit samples the water storage tank temperature (not included). If the water temperature is below the setpoint, then heat that is normally rejected to the outdoor condenser coil is instead rejected to a heat exchanger in the Ruud H₂AC Rooftop Unit to provide hot water. The setpoint has a default value of 95°F but self-adjusts to jobsite conditions to allow the maximum heat recovery. The preheated water leaving the storage

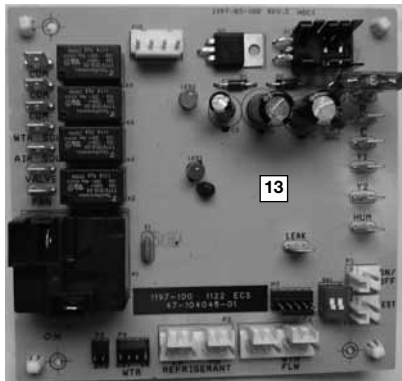

tank for the Ruud H₂AC Rooftop Unit must then be heated to the desired final temperature by a separate tank or tankless water heater.

The RLHL-D includes a water circulation pump (14), a double wall, vented, refrigerant-to-potable water heat exchanger (15), a 3-way refrigerant valve (16) to switch between the outdoor condenser coil and the refrigerant-to-water heat exchanger, idle heat exchanger refrigerant pumpdown solenoid valves (17), and a water pressure switch (18) to prevent operation of the water pump if water is not present. All are controlled by the *eSync Integration Technology* control. The unit also includes an air vent (19) to automatically bleed air from the water lines, and a water leak detector (20) that will shut down water heating operation should a leak be detected and can send an alarm over a BAS network to notify others. In the event of this alarm, an optional field-installed water shut-off valve is available to disconnect the unit from the potable water supply.

The rear of the unit includes potable water line connections to the water storage tank for the Ruud H₂AC Rooftop Unit. For ease of installation, pipe unions (21) are provided to connect to 1-1/2" nominal copper water lines. The lines are provided with plastic covers to keep out contaminants until the system is installed.

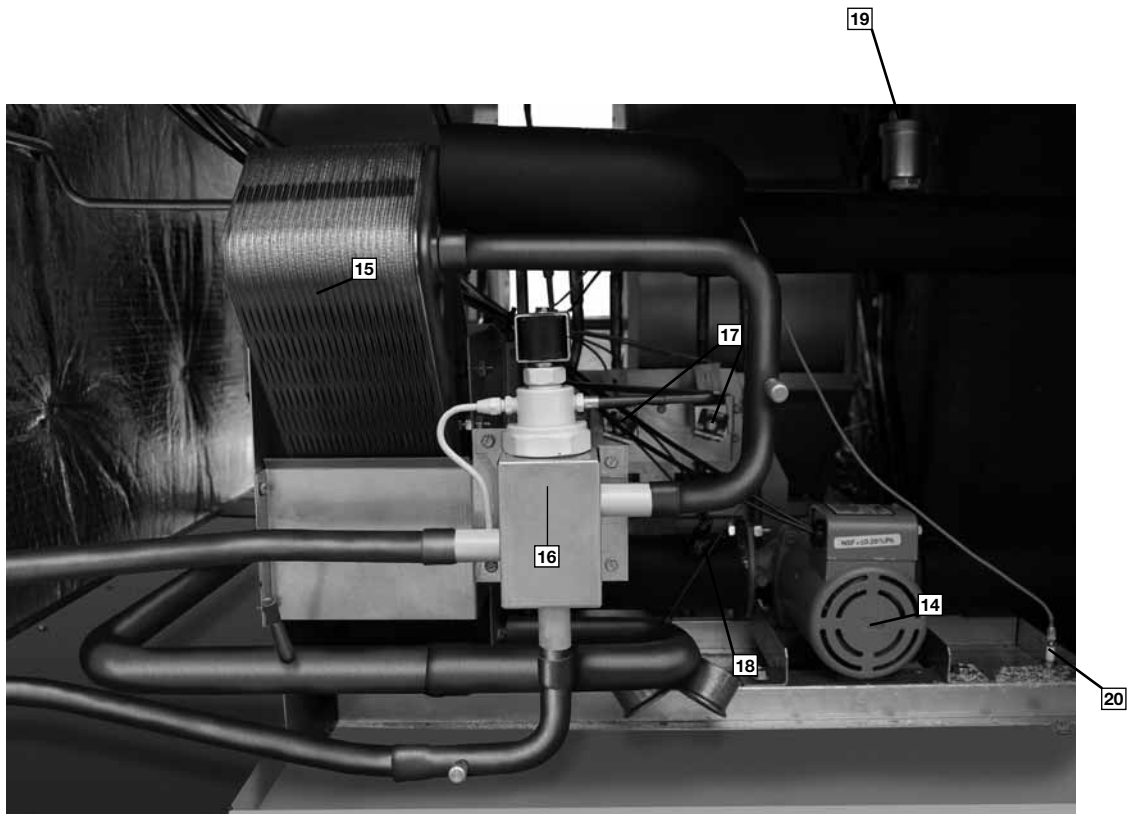
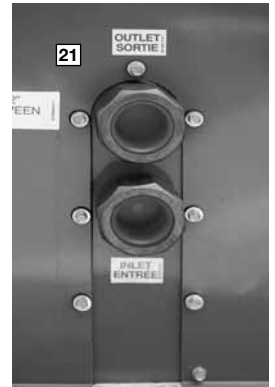

For added convenience in the field, a factory-installed convenience outlet (22) is available. Low and High voltage can enter either from the side or through the base. Low-voltage connections are made through the low-voltage terminal strip. For ease of access, the U.L.-required low voltage barrier can be temporarily removed for low-voltage termination and then reinstalled. The high-voltage connection is terminated at the high voltage terminal block. The suggested mounting for the field-installed disconnect is on the exterior side of the electrical control box.



The blower compartment is to the right of the control box and can be accessed by 1/4 turn latches. To allow easy maintenance of the blower assembly, the entire assembly easily slides out by removing four #10 screws from the blower assembly. The adjustable motor pulley (24) can easily be adjusted by loosening the bolts on either side of the motor mount. Removing the bolts allows for easy removal of the blower pulley by pushing the blower assembly up to loosen the belt. Once the belt is removed, the motor sheave can be adjusted to the desired number of turns, ranging from 1 to 6 turns open. Where the demands for the job require high static, Ruud has high-static drives available

that deliver nominal airflow up to 2" of static. By referring to the airflow performance tables listed in the installation instructions, proper static pressure and CFM requirements can be dialed in. The scroll housing (25) and blower

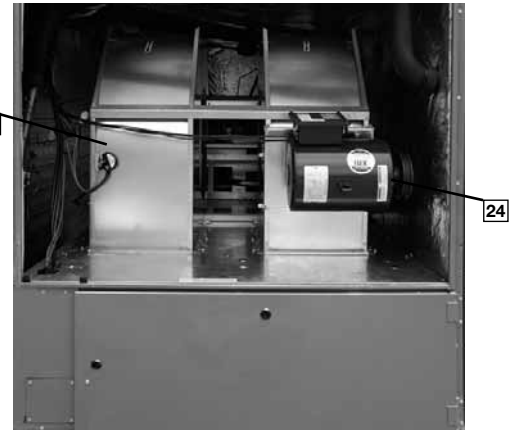

scroll provide quiet and efficient airflow. The blower sheave is secured by an "H" bushing which firmly secures the pulley to the blower shaft for years of trouble-free operation. The "H" bushing allows for easy removal of the blower pulley from the shaft, as opposed to the use of a set screw, which can score the shaft, creating burrs that make blower-pulley removal difficult.

Also inside the blower compartment are the optional low-ambient controls (26). The optional low-ambient controls allow for operation of the compressors down to 0 degrees ambient temperature by cycling the outdoor fans on high pressure. The freeze sensor protects the compressor if the evaporator coil gets too cold (below freezing) due to low airflow, and allows monitoring of the suction line temperature on the controller display. The sensor clips on the suction line near the evaporator outlet.



Inside the blower compartment the interlaced evaporator can also be viewed. The evaporator uses enhanced fin technology for maximum heat transfer. The TXV metering device assures even distribution of refrigerant throughout the evaporator.

Wiring throughout the unit is neatly bundled and routed. Where wire harnesses go through the condenser bulkhead or blower deck, a molded wire harness assembly (27) provides an airtight and water-tight seal, and provides strain relief. Care is also taken to tuck raw edges of insulation behind sheet metal to improve indoor air quality.

The heating compartment contains the latest electric furnace technology on the market. The 100% efficient electric furnace can be factory-installed or easily field-installed. Built with ease-of-installation in mind, the electric furnace is completely wired up for slide-in, plug-and-play installation in the field. With choices of up to four kilowatt offerings, the contractor is assured to get the correct amount of heating output to meet the designed heating load.

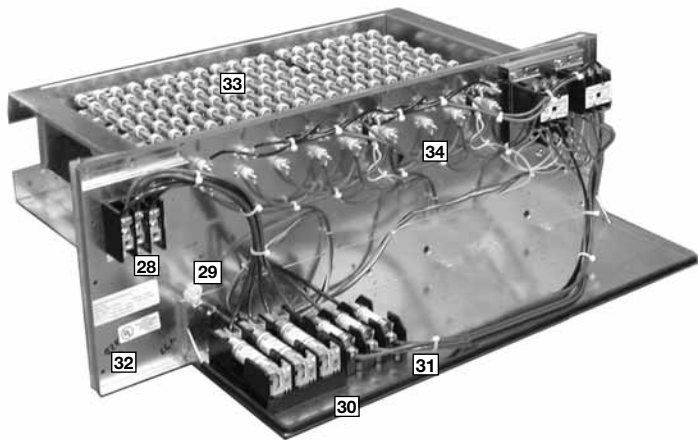

Power hook-up in the field is easy with single-point wiring to a terminal block (28) and a polarized plug for the low-voltage connection (29). The electric furnace comes with fuses for the unit (30) and for the electric furnace (31), and is UL certified (32). The electric heating elements are of a wound-wire construction (33) and isolated with ceramic bushings. The limit switch (34) protects the design from over-temperature conditions.

The compressor compartment houses the heartbeat of the unit. The scroll compressor (36) is known for its long life, and for reliable, quiet, and efficient operation. The suction and discharge lines are designed with shock loops (37) to absorb the strain and stress that the starting torque, steady state operation, and shut down cycle impose on the refrigerant tubing. Each compressor and circuit is independent for built-in redundancy, and each circuit is clearly marked throughout the system. Each unit has two stages of efficient cooling operation; first stage is approximately 50% of second stage.

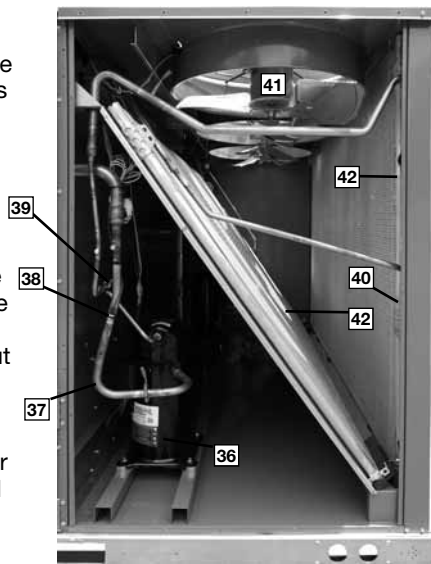

The low-pressure switches (38) and high-pressure switches (39) are mounted on the appropriate refrigerant lines in the condenser section. The high-pressure switch will shut off the compressors if pressures exceeding 610 PSIG are detected as may occur if the outdoor fan motor fails. The low-pressure switches shut off the compressors if low pressure is detected due to loss of refrigerant charge. Each factory-installed option is brazed into the appropriate high or low side and wired appropriately. Use of polarized plugs allow for easy field inspection and repair. Each unit comes standard with filter dryer (40).

The condenser fan motor (41) can easily be accessed and maintained by removing the protective fan grille. The polarized plug connection allows the motor to be changed quickly and eliminates the need to snake wires through the unit.

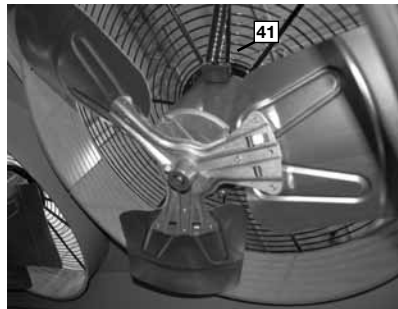

The outdoor coil uses the latest MicroChannel technology (42) for the most effective method of heat transfer. The outdoor coil is protected by optional* louvered panels, which allow unobstructed airflow while protecting the unit from both Mother Nature and vandalism. These units are designed for downflow applications only (43). The return air compartment can also contain an economizer (44).

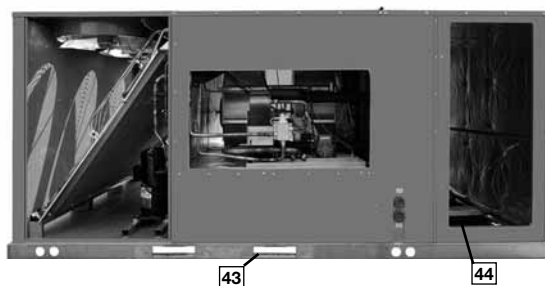

Two economizer models exist for downflow applications (a downflow economizer with factory installed smoke detector in the return section is available. Each unit is prewired for the economizer to allow quick plug-in installation. The economizer is also available as a factory-installed option.

The economizer, which provides free cooling when outdoor conditions are suitable and also provides fresh air to meet local requirements, comes standard with single enthalpy controls. The controls can be upgraded to dual enthalpy easily in the field. The direct drive actuator combined with gear drive dampers has eliminated the need for linkage adjustment in the field. The economizer control has a minimum position setpoint, an outdoor-air enthalpy setpoint, a mixed-air temperature setpoint, and an indoor CO₂ level setpoint.

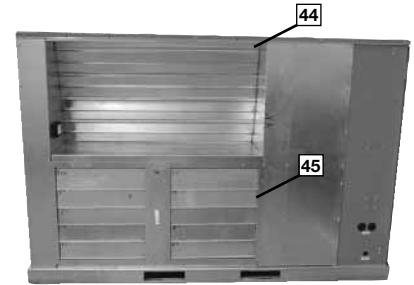

Barometric relief (45) is standard on all economizers. Power Exhaust is easily field installed. The power exhaust is housed in the barometric relief opening and is easily slipped in with a plugin assembly. The wire harness to the economizer also has accommodations for a smoke detector.

The damper minimum position, actual damper position, power exhaust on/off setpoint, mixed air temperature limit setpoint and Demand Controlled Ventilation (DCV) setpoint can be read and adjusted at the unit controller display or remotely through a network connection.

The Space CO₂ level, mixed air temperature, and Economizer Status (Free Cooling Available, Single or Dual Enthalpy) can be read at the unit controller display or remotely through a network connection. Economizer Faults will trigger a network Alarm and can be read at the unit controller display or remotely through a network connection.

The Ruud roofcurb (46) is made for toolless assembly at the jobsite by inserting a pin into a hinge in each corner of the adjacent curb sides (47), which makes the assembly process quick and easy.



R L H L — D 180 C L 000 X X X

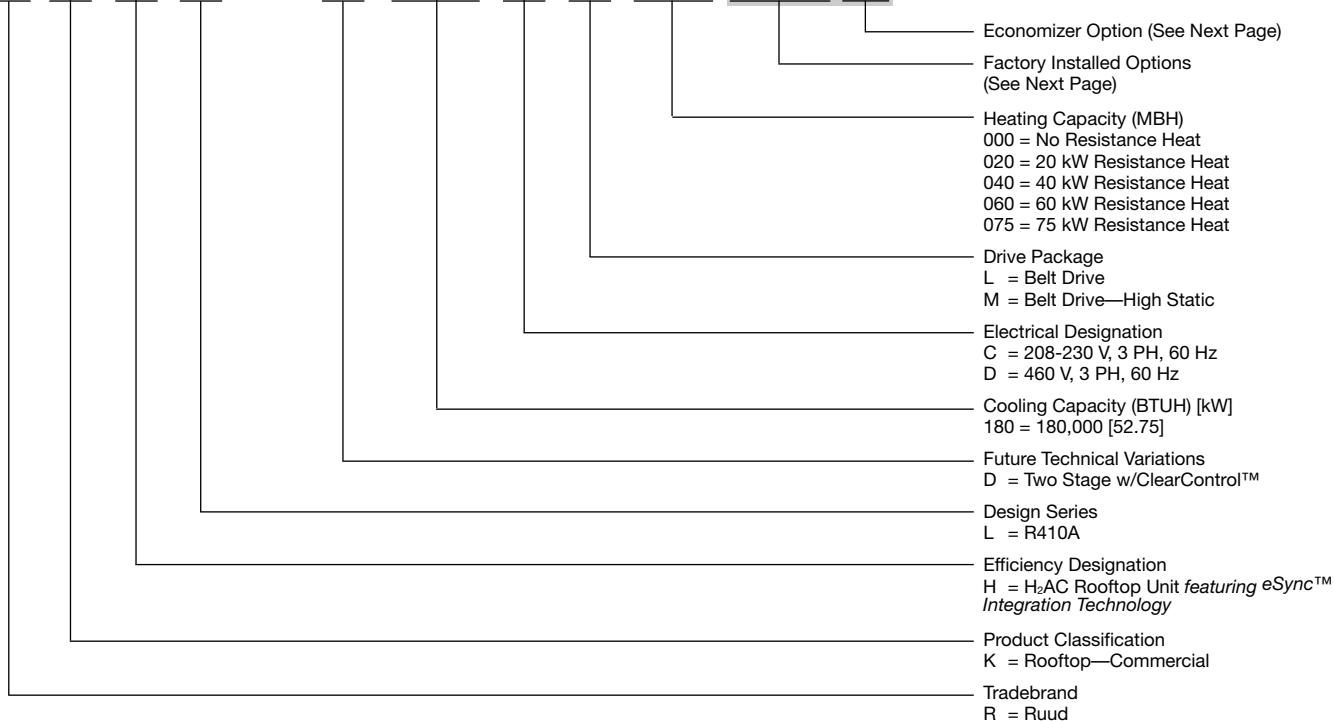

[] Designates Metric Conversions

FACTORY INSTALLED OPTION CODES FOR RLHL-D (15 TON) [52.8 kW]

Option Code	Hail Guard	Non-Powered Convenience Outlet	Low Ambient/ Comfort Alert
AD	X		
AG		X	
AR		X	X
JD	X		X
BJ	X	X	
JE		X	X
CZ	X	X	X

NOTES: (1) High and low pressure is standard on all models.
"x" indicates factory installed option.

ECONOMIZER SELECTION FOR RLHL-D (15 TON) [52.8 kW]

Option Code	No Economizer	DDC Single Enthalpy Economizer w/Barometric Relief	DDC Single Enthalpy Economizer w/Barometric Relief and Smoke Detector
A	X		
H		X	
J			X

"x" indicates factory installed option.

Instructions for Factory Installed Option(s) Selection

Note: Three characters following the model number will be utilized to designate a factory-installed option or combination of options. If no factory option(s) is required, nothing follows the model number.

Step 1. After a basic rooftop model is selected, choose a *two-character* option code from the FACTORY INSTALLED OPTION SELECTION TABLE.

Proceed to Step 2.

Step 2. The last option code character is utilized for factory-installed economizers. Choose a character from the FACTORY INSTALLED ECONOMIZER SELECTION TABLE.

Examples:

RLHL-D180CL000.....this unit has no factory installed options.

RLHL-D180CL000**ADA**.....this unit is equipped with *hail guards*.

RLHL-D180CL000**JDA**.....this unit is equipped with *hail guards, low ambient and Comfort Alert*.

RLHL-D180CL000**JDH**.....this unit is equipped as above and includes an *Economizer with single enthalpy sensor and with barometric relief*.

RLHL-D180CL000**AAJ**.....this unit is equipped with an *Economizer with single enthalpy sensor and Barometric Relief with smoke detector*.

[] Designates Metric Conversions

To select an RLHL-D Cooling and Heating unit to meet a job requirement, follow this procedure, with example, using data supplied in this specification sheet.

1. DETERMINE COOLING AND HEATING REQUIREMENTS AND SPECIFIC OPERATING CONDITIONS FROM PLANS AND SPECS.

Example:

Voltage—	240V—3 Phase — 60 Hz
Total Cooling Capacity—	168,000 BTUH [49.2 kW]
Sensible Cooling Capacity —	120,000 BTUH [35.1 kW]
Heating Capacity —	175,000 BTUH [51.2 kW]
*Condenser Entering Air —	95°F [35.0°C] DB
*Evaporator Mixed Air Entering —	65°F [18.3°C] WB 78°F [25.6°C] DB
*Indoor Air Flow (vertical) —	6000 CFM [2831 L/s]
*External Static Pressure —	0.40 in. WG [.10 kPa]

2. SELECT UNIT TO MEET COOLING REQUIREMENTS.

Since total cooling is within the range of a nominal 15 ton [52.7 kW] unit, enter cooling performance table at 95°F [35.0 °C] DB condenser inlet air. Interpolate between 63°F [17.2 °C] WB and 67°F [19.4 °C] WB to determine total and sensible capacity and power input for 65°F [18.3 °C] WB evaporator inlet air at 5800 CFM [2737 L/s] indoor air flow (table basis):

Total Cooling Capacity = 178,950 BTUH [52.40 kW]
Sensible Cooling Capacity = 147,400 BTUH [43.16 kW]
Power Input (Compressor and Cond. Fans) = 12,600 watts

Use formula in note (1) to determine sensible capacity at 78°F [25.6 °C] DB evaporator entering air:

$$147,400 + (1.10 \times 6,000 \times (1 - 0.11) \times (78 - 80))$$

Sensible Cooling Capacity = 135,652 BTUH [39.72 kW]

3. CORRECT CAPACITIES OF STEP 2 FOR ACTUAL AIR FLOW.

Select factors from airflow correction table at 6000 CFM [2831 L/s] and apply to data obtained in step 2 to obtain gross capacity:

Total Capacity = 178,950 x 1.01 = 180,740 BTUH [52.92 kW]
Sensible Capacity = 135,652 x 1.02 = 138,365 BTUH [40.51 kW]
Power Input = 12,600 x 1 = 12,600 Watts

These are Gross Capacities, not corrected for blower motor heat or power.

4. DETERMINE BLOWER SPEED AND WATTS TO MEET SYSTEM DESIGN.

Enter Indoor Blower performance table at 6000 CFM [2831 L/s]. Total ESP (external static pressure) per the spec of 0.40 in. WG [.10 kPa] includes the system duct and grilles. Add from the table 'Component Air Resistance', 0.08 in. WG [.02 kPa] for wet coil, 0 in. WG [.00 kPa] for downflow air flow, for a total selection static pressure of 0.48 (0.5) in. WG [.12 kPa], and determine:

RPM = 631
WATTS = 1,824
DRIVE = L (standard 3 H.P. motor)

5. CALCULATE INDOOR BLOWER BTUH HEAT EFFECT FROM MOTOR WATTS, STEP 4.

$$1,824 \times 3.412 = 6,223 \text{ BTUH [1.82 kW]}$$

6. CALCULATE NET COOLING CAPACITIES, EQUAL TO GROSS CAPACITY, STEP 3, MINUS INDOOR BLOWER MOTOR HEAT.

$$\text{Net Total Capacity} = 180,740 - 6,223 = 174,517 \text{ BTUH [51.10 kW]}$$

$$\text{Net Sensible Capacity} = 138,365 - 6,223 = 132,142 \text{ BTUH [38.69 kW]}$$

7. CALCULATE UNIT INPUT AND JOB EER.

$$\text{Total Power Input} = 12,600 \text{ (step 3)} + 1,824 \text{ (step 4)} = 14,424 \text{ Watts}$$

$$\text{EER} = \frac{\text{Net Total BTUH [kW] (step 6)}}{\text{Power Input, Watts (above)}} = \frac{174,517}{14,424} = 12.1$$

8. SELECT UNIT HEATING CAPACITY.

From Heater Kit Table select kW to meet heating capacity requirement multiply kW x 3412 to convert to BTUH

Use 60 kW Heater Kit

Heater Kit Model: RXJJ-CE60C

Heating Capacity = 196,160 BTUH [57.4 kW]

Add indoor blower heat effect (STEP 5) to Heater Kit Capacity to get total heating capacity:

$$196,160 + 6,223 = 202,383 \text{ BTUH [59.3 kW]}$$

9. CHOOSE MODEL RLHL-D180CL060

*NOTE: These operating conditions are typical of a commercial application in a 95°F/79°F [35°C/26°C] design area with indoor design of 76°F [24°C] DB and 50% RH and 10% ventilation air, with the unit roof mounted and centered on the zone it conditions by ducts.

[] Designates Metric Conversions

Whenever a call for cooling is present, the H₂AC Rooftop Unit samples the temperature of the storage tank. If it is below the setpoint, then heat that is normally rejected to the outdoor condenser coil is instead rejected to a heat exchanger in the H₂AC Unit to provide hot water. The preheated water leaving the storage tank must then be heated to the desired final temperature by a separate tank or tankless heater. The cost savings are provided by the difference between heating water from the ground temperature to the final hot water temperature versus heating water from the storage tank temperature to the final hot water temperature.

1. Calculate daily cost of operation of existing water heating equipment.

Hot Water Consumption (gallons)	Water Specific Weight (lbm/gallon)	Hot Water Temperature (°F)	Ground Water (Cold Water) Temperature (°F)	*Required Water Heating Output (therms)
2100	8.33	185	73.5	19.505

* = 2100 gallons x 8.33 lbm/gallon x (185°F - 73.5 °F) x 1 Btu/(1 lbm x 1 °F) x (1 therm/100,000 Btu)

Water Heater Type	Water Heater Thermal Efficiency	Water Heating Input (therms)	Fuel Cost	Water Heating Cost
Natural Gas Storage Tank	0.80	24.381	\$1.077 per therm (\$/thm)	\$26.26
Propane Gas Storage Tank	0.80	24.381	\$1.210 per gallon of Propane (\$/gal)	\$32.22
Hi-e Natural Gas Storage Tank	0.94	20.750	\$1.077 per therm (\$/thm)	\$22.35
Hi-e Propane Gas Storage Tank	0.94	20.750	\$1.210 per gallon of Propane (\$/gal)	\$27.43
Electric Storage Tank	0.98	19.903	\$0.127 per kiloWatt hour (\$/kWh)	\$74.08
Tankless Natural Gas	0.94	20.750	\$1.077 per therm (\$/thm)	\$22.35
Tankless Propane Gas	0.94	20.750	\$1.210 per gallon of Propane (\$/gal)	\$27.43

(Required Water Heating Output/Thermal Efficiency = Water Heating Input)

2. Calculate daily cost savings from H₂AC operation.

Daily hours when hot water is required without air conditioner operation available 0
 Storage Tank Leaving Water Temperature (°F) - Maximum temperature is 125°F 120
 Required H₂AC Water Heating Output (thm) = 2100 gallons x 8.33 lbm/gallon x (120°F - 73.5 °F) x 1 Btu/(1 lbm x 1 °F) x (1 therm/100,000 Btu) x ((24-0)/24) 8.13

Water Heater Type	Water Heater Thermal Efficiency	Water Heating Input (therms)	Fuel Cost	Water Heating Cost
Natural Gas Storage Tank	0.80	14.213	\$1.077 per therm (\$/thm)	\$15.31
Propane Gas Storage Tank	0.80	14.213	\$1.210 per gallon of Propane (\$/gal)	\$18.79
Hi-e Natural Gas Storage Tank	0.94	12.096	\$1.077 per therm (\$/thm)	\$13.03
Hi-e Propane Gas Storage Tank	0.94	12.096	\$1.210 per gallon of Propane (\$/gal)	\$15.99
Electric Storage Tank	0.98	11.603	\$0.127 per kiloWatt hour (\$/kWh)	\$43.18
Tankless Natural Gas	0.94	12.096	\$1.077 per therm (\$/thm)	\$13.03
Tankless Propane Gas	0.94	12.096	\$1.210 per gallon of Propane (\$/gal)	\$15.99

** (Required Water Heating Output - Required H₂AC Water Heating Output)/Thermal Efficiency

The savings in fuel to provide hot water are offset a bit by higher air conditioning costs in the water heating mode especially during mild weather. The calculations below provide the electrical cost increase for the worst case (mild weather) and for the best case (summer design conditions). The results assume AHRI return air conditions (80°F db/ 67°F wb).

3. Calculate daily increase in electricity cost from eSync operation.

Summer Design Outdoor Air Temperature (°F) 95
 Minimum Outdoor Air Temperature, Cooling Mode (°F) 75
 Gross Watts Air Conditioning Mode @ Summer Design Outdoor Air Temperature (kW) from Gross Capacity Tables 12.70
 Gross Watts Air Conditioning Mode @ Minimum Outdoor Air Temperature Cooling Mode (kW) from Gross Capacity Tables 10.50
 Gross Watts Water Heating Mode @ Storage Tank Leaving Water Temperature (kW) from Tables 7.10
 Gross Capacity Water Heating Mode @ Storage Tank Leaving Water Temperature (Btuh) from Tables 119,300
 Gross Watts 2nd Stage Correction (kW) @ Summer Design Outdoor Air Temperature from Tables 6.73
 Gross Watts 2nd Stage Correction (kW) @ Minimum Outdoor Air Temperature from Tables 5.73
 Correction Factor for H₂AC Unit Operation during occupied hours 0.89
 Water Heating Mode Time (hours) = 8.1342 thm x (100,000 Btuh/thm) / (0.89 x 119,300 Btuh) 7.660
 Summer Design Conditions savings decrease = ((24-0) hrs/ 24 hrs) x 7.660 hrs x ((7.1+6.73) - 12.7) kW x 0.127 \$/kWh -\$1.10
 Minimum Outdoor Air Temperature savings decrease = ((24-0) hrs/ 24 hrs) x 7.660 hrs x ((7.1+5.73) - 10.5) kW x 0.127 \$/kWh -\$2.27

4. Subtract the values above from the Water Heating Costs in step 2 to find total daily savings.

For example, replacing a Natural Gas Storage Tank system with an H₂AC unit and a Tankless Natural Gas system will conservatively save \$26.26 - \$13.03 - \$2.27 = \$10.96 per day. The new cost of heating water is only 58% of the original cost.
 Adding an H₂AC unit to an existing natural gas water heater will conservatively save \$26.26 - \$15.31 - \$2.27 = \$8.68 per day. The new cost of heating water is only 67% of the original cost.

The H₂C system with storage tank can provide any water heating system, tank or tankless, with preheated water. The water heating system must be sized properly for each installation.

The tankless system shown below is just one example of a typical installation and may not be suitable for all applications. See the water heater manufacturers recommendation for sizing and product specifications.

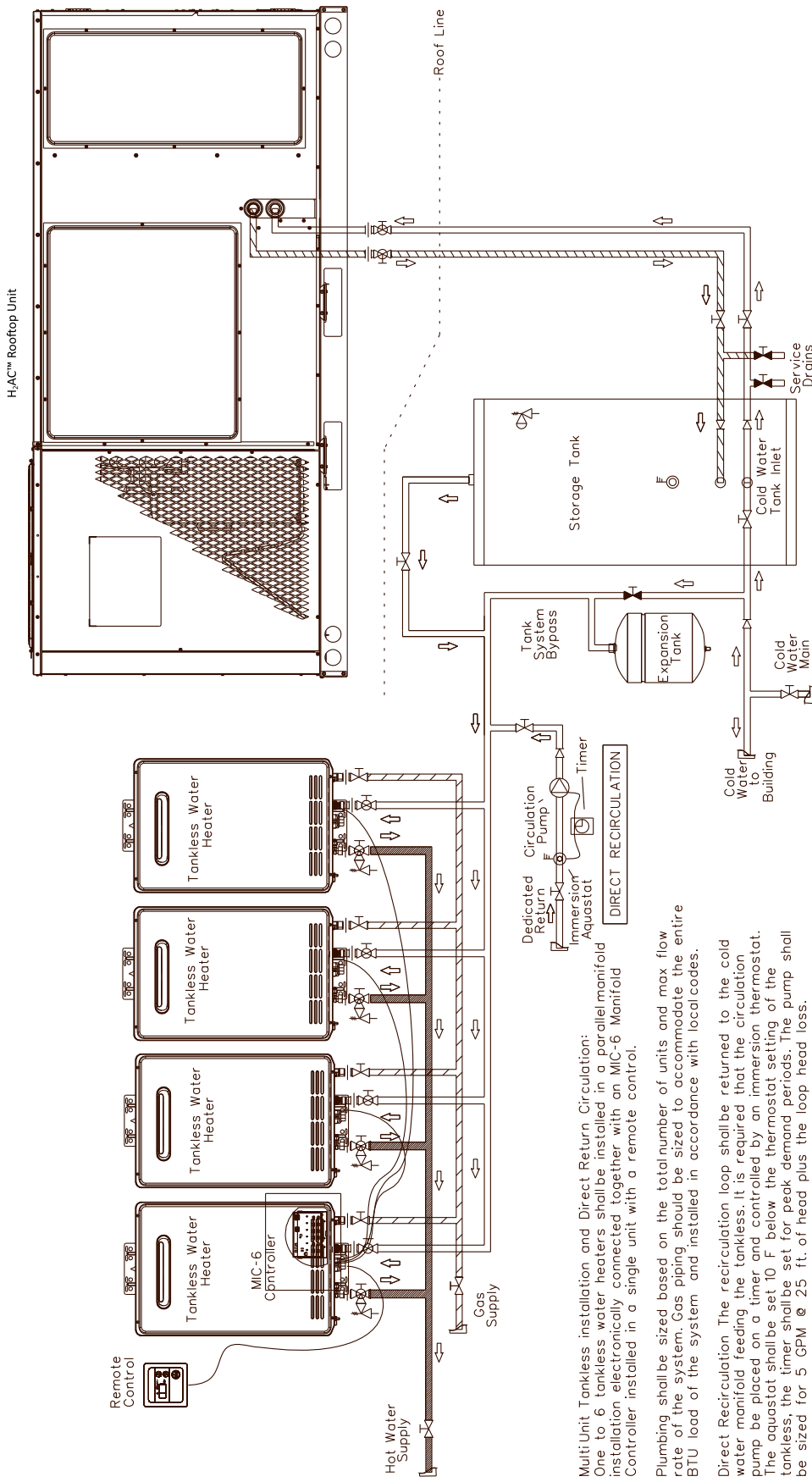

Multi Unit Tankless Installation and Direct Return Circulation:
One to 6 tankless water heaters shall be installed in a parallel manifold installation electronically connected together with an MIC-6 Manifold Controller installed in a single unit with a remote control.

Plumbing shall be sized based on the total number of units and max flow rate of the system. Gas piping should be sized to accommodate the entire BTU load of the system and installed in accordance with local codes.

Direct Recirculation The recirculation loop shall be returned to the cold water manifold feeding the tankless. It is required that the circulation pump be placed on a timer and controlled by an immersion thermostat. The aquastat shall be set 10 F below the thermostat setting of the tankless, the timer shall be set for peak demand periods. The pump shall be sized for 5 GPM @ 25 ft. of head plus the loop head loss.

Legend

- Cold Water Isolator Valve Assembly
- Hot Water Isolator Valve Assembly
- Pressure Relief Valve
- Circulation Pump
- Normally Open Shut-off Valve
- Normally Closed Shut-off Valve
- Check Valve
- Union
- Gas Pipe
- Cold Water Pipe
- Hot Water Pipe
- Return Circulation Line

This drawing is intended as a guide only. It is not to be used as an alternative to a professionally engineered project drawing. This drawing does not imply compliance with local building codes. Installation may vary, depending on installation location, and must be done in accordance with all local building codes. Consult with local building officials prior to installation.

The chart below shows the H₂AC Rooftop Unit Water Flow Rate versus the Available Pressure Water Pressure drop. When selecting the location of the H₂AC Rooftop Unit, do not exceed the maximum Equivalent Feet of tubing between the H₂AC Rooftop Unit and the storage tank to ensure proper performance at available voltage. Higher GPM will provide a higher storage tank temperature.

Water Flow Rate (GPM) (15 GPM minimum)	15	20	25	30
Water Velocity (fps)	2.71	3.61	4.51	5.41
Available Pressure Head at Unit @ 230/460 Volts (Head ft.) (psig)	30.3 13.1	23.8 10.3	16.3 7.1	7.7 3.3
Maximum Equivalent Feet of 1-1/2" Nom. Type L Copper Tubing (ft.)	1504	695	314	106
Available Pressure Head at Unit @ 208 Volts (Head ft.) (psig)	26.8 11.6	19.5 8.4	11.3 4.9	2.2 0.9
Maximum Equivalent Feet of 1-1/2" Nom. Type L Copper Tubing (ft.)	1332	569	218	30

In a closed system application the static (elevation) head is ignored. Only the pipe friction is used to calculate pressure drop.

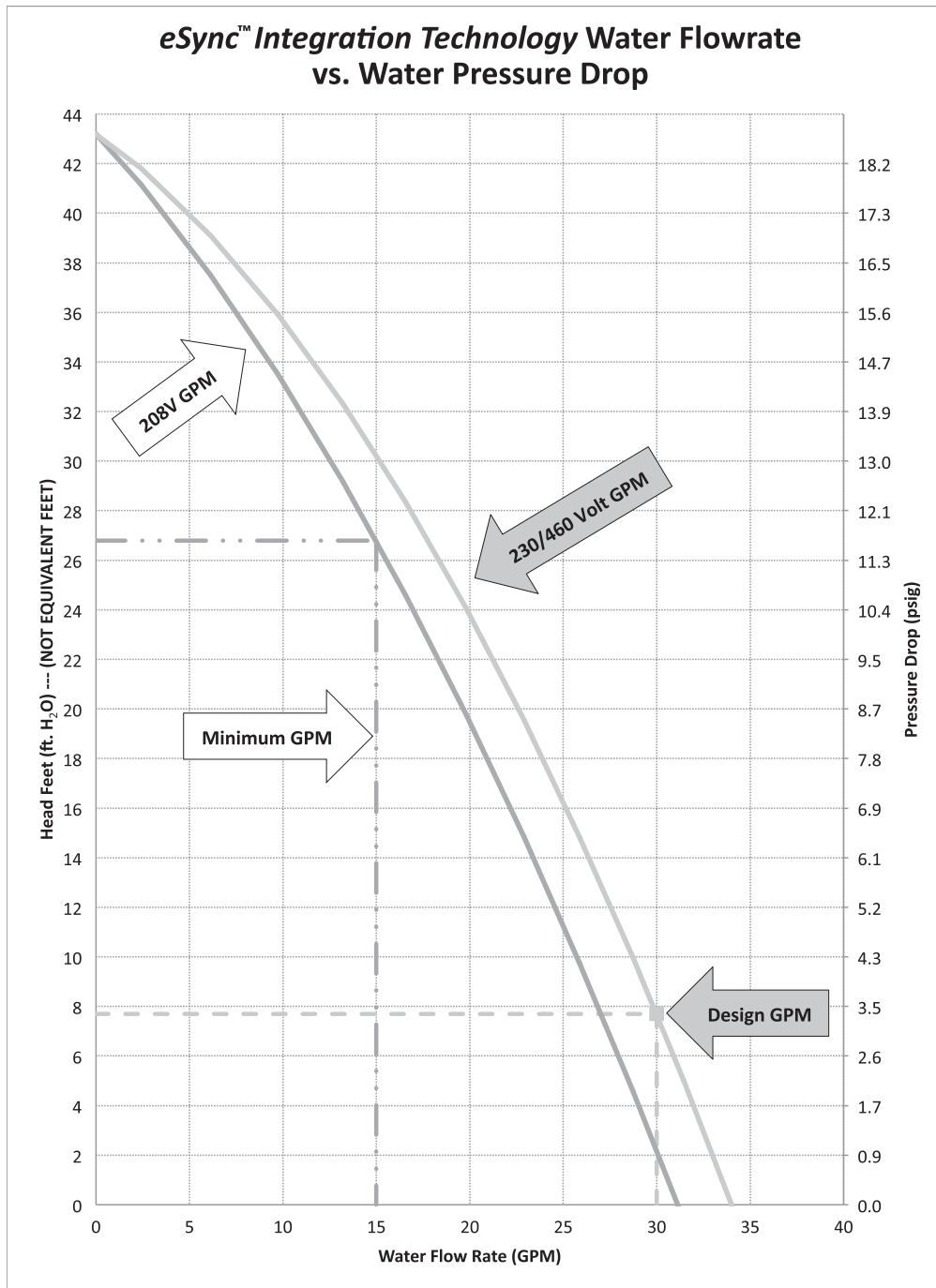

PROCEDURE FOR CALCULATING THE TOTAL EQUIVALENT LENGTH OF TUBING

List all piping components from the Storage Tank to the H₂AC Rooftop Unit and back to the storage tank. The equivalent length of straight tubing is the same as the actual length. The equivalent length of fittings are obtained from the table below. Sum all of the individual component lengths to find the Total Equivalent Length Pressure Loss in Fitting and Valve.

PRESSURE LOSS IN FITTINGS AND VALVES EXPRESSED AS EQUIVALENT LENGTH OF TUBE (FT.)

Tube Nominal or Standard Size (inches)	1-1/2"	2"	
Fittings	Standard 90° Elbow	4	5.5
	Standard 45° Elbow	1.5	2
	90° Tee - Side Branch	7	9
	90° Tee - Straight Run	0.5	0.5
Valves	Coupling	0.5	0.5
	Ball	0.5	0.5
	Gate	—	0.5
	Btfly	—	7.5
	Check	6.5	9

Data condensed from Table 7 "Pressure Loss in Fittings & Valves Expressed as Equivalent Length of Tube" of the Copper Development Association. Allowances are for streamlined soldered fittings and recessed threaded fittings. The equivalent lengths presented above are based upon a C factor of 150 in the Hazen-Williams friction loss formula. The lengths shown are rounded to the nearest half foot.

PIPE FITTINGS BY NUMBER

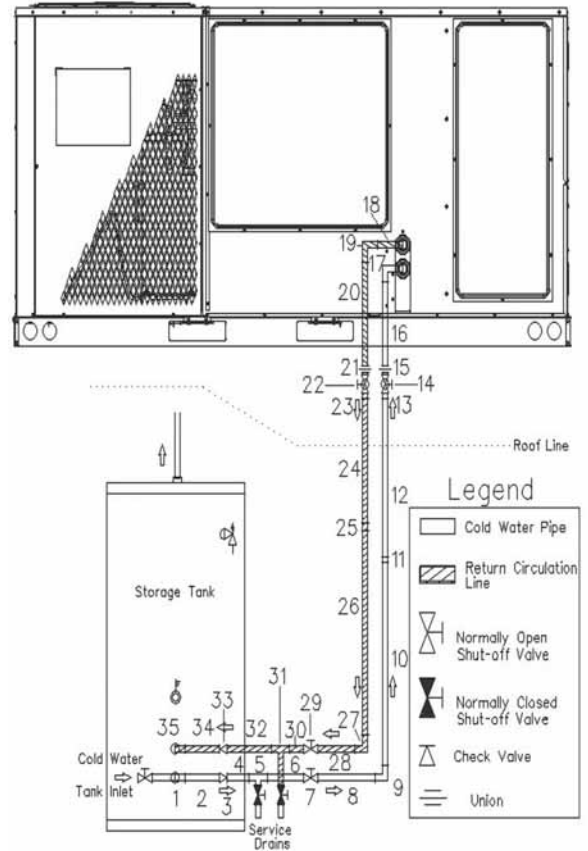

TOTAL EQUIVALENT LENGTH OF FITTINGS

No.	Inlet	EQUIVALENT Length (ft.)	No.	Outlet	EQUIVALENT Length (ft.)
1	side branch Tee	7	18	straight tubing	1
2	straight tubing	1	19	90° elbow	4
3	Check valve	6.5	20	straight tubing	0.5
4	straight tubing	0.5	21	1-1/2" MPT adapter ①	1
5	straight run Tee	0.5	22	Ball Isolation valve	0.5
6	straight tubing	1.5	23	1-1/2" MPT adapter ①	1
7	Ball valve	0.5	24	straight tubing	20
8	straight tubing	5	25	coupling	0.5
9	90° elbow	4	26	straight tubing	19.6
10	straight tubing	20	27	90° elbow	4
11	coupling	0.5	28	straight tubing	4
12	straight tubing	20	29	Ball valve	0.5
13	1-1/2" MPT adapter ①	1	30	straight tubing	1.5
14	Ball Isolation valve	0.5	31	straight run Tee	0.5
15	1-1/2" MPT adapter ①	1	32	straight tubing	0.5
16	straight tubing	0.5	33	Check valve	6.5
17	90° elbow - fitting	4	34	straight tubing	1
			35	90° elbow	4
Total Equivalent Length					144.6

*NOTES: ① For threaded fittings, double the allowances shown in the table.

Data condensed from Table 7 of the Copper Development Organization. Allowances are for streamlined soldered fittings and recessed threaded fittings. The equivalent lengths presented above are based upon a C factor of 150 in the Hazen-Williams friction loss formula. The lengths shown are rounded to the nearest half foot.

NOM. SIZES 15 TON [52.8 kW] ASHRAE 90.1-2007 COMPLIANT MODELS

Model RLHL- Series	D180CL	D180CM	D180DL	D180DM
Cooling Performance¹				
Gross Cooling Capacity Btu [kW]	182,000 [53.33]	182,000 [53.33]	182,000 [53.33]	182,000 [53.33]
EER/SEER ²	12.4/NA	12.4/NA	12.4/NA	12.4/NA
Nominal CFM/AHRI Rated CFM [L/s]	6000/5800 [2831/2737]	6000/5800 [2831/2737]	6000/5800 [2831/2737]	6000/5800 [2831/2737]
AHRI Net Cooling Capacity Btu [kW]	176,000 [51.57]	176,000 [51.57]	176,000 [51.57]	176,000 [51.57]
Net Sensible Capacity Btu [kW]	130,400 [38.21]	130,400 [38.21]	130,400 [38.21]	130,400 [38.21]
Net Latent Capacity Btu [kW]	45,600 [13.36]	45,600 [13.36]	45,600 [13.36]	45,600 [13.36]
IEER ³	13	13	13	13
Net System Power kW	14.23	14.23	14.23	14.23
Compressor				
No./Type	2/Scroll	2/Scroll	2/Scroll	2/Scroll
Outdoor Sound Rating (dB)⁴				
	91	91	91	91
Outdoor Coil—Fin Type				
Tube Type	Louvered	Louvered	Louvered	Louvered
MicroChannel Depth in. [mm]	MicroChannel	MicroChannel	MicroChannel	MicroChannel
Face Area sq. ft. [sq. m]	1 [25.4]	1 [25.4]	1 [25.4]	1 [25.4]
Rows / FPI [FPcm]	50.8 [4.72]	50.8 [4.72]	50.8 [4.72]	50.8 [4.72]
	1 / 23 [9]	1 / 23 [9]	1 / 23 [9]	1 / 23 [9]
Indoor Coil—Fin Type				
Tube Type	Louvered	Louvered	Louvered	Louvered
Tube Size in. [mm] OD	Rifled	Rifled	Rifled	Rifled
Face Area sq. ft. [sq. m]	0.375 [9.5]	0.375 [9.5]	0.375 [9.5]	0.375 [9.5]
Rows / FPI [FPcm]	26.67 [2.48]	26.67 [2.48]	26.67 [2.48]	26.67 [2.48]
Refrigerant Control	2 / 18 [7]	2 / 18 [7]	2 / 18 [7]	2 / 18 [7]
Drain Connection No./Size in. [mm]	TX Valves	TX Valves	TX Valves	TX Valves
	1/1 [25.4]	1/1 [25.4]	1/1 [25.4]	1/1 [25.4]
Outdoor Fan—Type				
No. Used/Diameter in. [mm]	Propeller	Propeller	Propeller	Propeller
Drive Type/No. Speeds	3/24 [609.6]	3/24 [609.6]	3/24 [609.6]	3/24 [609.6]
CFM [L/s]	Direct/1	Direct/1	Direct/1	Direct/1
No. Motors/HP	10000 [4719]	10000 [4719]	10000 [4719]	10000 [4719]
Motor RPM	3 at 1/3 HP	3 at 1/3 HP	3 at 1/3 HP	3 at 1/3 HP
	1075	1075	1075	1075
Indoor Fan—Type				
No. Used/Diameter in. [mm]	FC Centrifugal	FC Centrifugal	FC Centrifugal	FC Centrifugal
Drive Type	2/18x9 [457x229]	2/18x9 [457x229]	2/18x9 [457x229]	2/18x9 [457x229]
No. Speeds	Belt (Adjustable)	Belt (Adjustable)	Belt (Adjustable)	Belt (Adjustable)
No. Motors	Single	Single	Single	Single
Motor HP	1	1	1	1
Motor RPM	3	5	3	5
Motor Frame Size	1725	1725	1725	1725
	56	184	56	184
Potable Water Heat Recovery				
Heat Exchanger Type	Vented Double-Wall Flat Plate	Vented Double-Wall Flat Plate	Vented Double-Wall Flat Plate	Vented Double-Wall Flat Plate
Material	Cu Brazed Stainless Steel	Cu Brazed Stainless Steel	Cu Brazed Stainless Steel	Cu Brazed Stainless Steel
No. Flat Plates	50	50	50	50
Unit Water Connections No./Size in. [mm]	2/1.625 [41.3]	2/1.625 [41.3]	2/1.625 [41.3]	2/1.625 [41.3]
Water Pump - Type				
Drive Type/No. Speeds	Centrifugal	Centrifugal	Centrifugal	Centrifugal
Housing Material	Direct/1	Direct/1	Direct/1	Direct/1
GPM [L/s]	Stainless Steel	Stainless Steel	Stainless Steel	Stainless Steel
Head Pressure ft. H2O [kPa]	30 [1.89]	30 [1.89]	30 [1.89]	30 [1.89]
Motor HP	25 [74.7]	25 [74.7]	25 [74.7]	25 [74.7]
Motor RPM	1/3	1/3	1/3	1/3
	3450	3450	3450	3450
Filter - Type				
Furnished	Disposable	Disposable	Disposable	Disposable
(NO.) Size Recommended in. [mm x mm x mm]	Yes	Yes	Yes	Yes
	(8)2x25x20 [51x635x508]	(8)2x25x20 [51x635x508]	(8)2x25x20 [51x635x508]	(8)2x25x20 [51x635x508]
Refrigerant Charge Oz. [g] (Sys. 1/Sys. 2)				
	171/201 [4848/5698]	171/201 [4848/5698]	171/201 [4848/5698]	171/201 [4848/5698]
Weights				
Net Weight lbs. [kg]	1895 [860]	1924 [873]	1895 [860]	1924 [873]
Ship Weight lbs. [kg]	2022 [917]	2051 [930]	2022 [917]	2051 [930]

See Page 18 for Notes.

[] Designates Metric Conversions

NOTES:

1. Cooling Performance is rated at 95° F ambient, 80° F entering dry bulb, 67° F entering wet bulb. Gross capacity does not include the effect of fan motor heat. AHRI capacity is net and includes the effect of fan motor heat. Units are suitable for operation to $\pm 20\%$ of nominal cfm. Units are certified in accordance with the Unitary Air Conditioner Equipment certification program, which is based on AHRI Standard 340/360.
2. EER and/or SEER are rated at AHRI conditions and in accordance with DOE test procedures.
3. Integrated Energy Efficiency Ratio (IEER) is rated in accordance with AHRI Standard 340/360.
4. Outdoor Sound Rating shown is tested in accordance with AHRI Standard 270.

GROSS SYSTEMS PERFORMANCE DATA—D180

		ENTERING INDOOR AIR @ 80°F [26.7°C] dbE ①									
wbE		71°F [21.7°C]			67°F [19.4°C]			63°F [17.2°C]			
CFM [L/s]		7200 [3398]	5800 [2737]	4800 [2265]	7200 [3398]	5800 [2737]	4800 [2265]	7200 [3398]	5800 [2737]	4800 [2265]	
DR ①		0.15	0.11	0.07	0.15	0.11	0.07	0.15	0.11	0.07	
OUTDOOR DRY BULB TEMPERATURE °F [°C]	75 [23.9]	Total BTUH [kW] Sens BTUH [kW] Power	222.0 [65.1] 137.7 [40.4] 10.9	212.7 [62.3] 123.8 [36.3] 10.6	206.0 [60.4] 113.8 [33.3] 10.5	210.7 [61.7] 162.8 [47.7] 10.7	201.9 [59.2] 146.4 [42.9] 10.5	195.5 [57.3] 134.6 [39.4] 10.3	205.6 [60.3] 188.7 [55.3] 10.6	197.0 [57.7] 169.6 [49.7] 10.4	190.8 [55.9] 156.0 [45.7] 10.2
	80 [26.7]	Total BTUH [kW] Sens BTUH [kW] Power	216.6 [63.5] 134.6 [39.4] 11.3	207.5 [60.8] 121.0 [35.5] 11.1	201.0 [58.9] 111.3 [32.6] 10.9	205.3 [60.2] 159.8 [46.8] 11.2	196.7 [57.6] 143.6 [42.1] 11.0	190.5 [55.8] 132.0 [38.7] 10.8	200.2 [58.7] 185.7 [54.4] 11.1	191.8 [56.2] 166.9 [48.9] 10.8	185.8 [54.5] 153.4 [45.0] 10.7
	85 [29.4]	Total BTUH [kW] Sens BTUH [kW] Power	211.3 [61.9] 131.6 [38.6] 11.9	202.4 [59.3] 118.3 [34.7] 11.6	196.0 [57.4] 108.8 [31.9] 11.4	200.0 [58.6] 156.8 [45.9] 11.7	191.6 [56.1] 140.9 [41.3] 11.5	185.6 [54.4] 129.6 [38.0] 11.3	194.9 [57.1] 182.7 [53.5] 11.6	186.7 [54.7] 164.2 [48.1] 11.3	180.8 [53.0] 151.0 [44.2] 11.2
	90 [32.2]	Total BTUH [kW] Sens BTUH [kW] Power	205.9 [60.3] 128.7 [37.7] 12.4	197.3 [57.8] 115.7 [33.9] 12.2	191.1 [56.0] 106.4 [31.2] 12.0	194.6 [57.0] 153.9 [45.1] 12.3	186.5 [54.6] 138.3 [40.5] 12.0	180.6 [52.9] 127.2 [37.3] 11.9	189.5 [55.5] 179.8 [52.7] 12.2	181.6 [53.2] 161.6 [47.3] 11.9	175.9 [51.5] 148.6 [43.5] 11.7
	95 [35]	Total BTUH [kW] Sens BTUH [kW] Power	200.6 [58.8] 125.9 [36.9] 13.1	192.2 [56.3] 113.2 [33.2] 12.8	186.1 [54.5] 104.1 [30.5] 12.6	189.3 [55.5] 151.1 [44.3] 12.9	181.4 [53.1] 135.8 [39.8] 12.7	175.7 [51.5] 124.8 [36.6] 12.5	184.2 [54.0] 177.0 [51.9] 12.8	176.5 [51.7] 159.0 [46.6] 12.5	171.0 [50.1] 146.2 [42.9] 12.3
	100 [37.8]	Total BTUH [kW] Sens BTUH [kW] Power	195.3 [57.2] 123.2 [36.1] 13.7	187.1 [54.8] 110.7 [32.4] 13.5	181.2 [53.1] 101.8 [29.8] 13.3	184.0 [53.9] 148.3 [43.5] 13.6	176.3 [51.7] 133.3 [39.1] 13.3	170.8 [50.0] 122.6 [35.9] 13.1	178.9 [52.4] 174.2 [51.1] 13.5	171.4 [50.2] 156.6 [45.9] 13.2	166.0 [48.7] 144.0 [42.2] 13.0
	105 [40.6]	Total BTUH [kW] Sens BTUH [kW] Power	190.0 [55.7] 120.6 [35.3] 14.5	182.0 [53.3] 108.4 [31.8] 14.2	176.3 [51.7] 99.6 [29.2] 14.0	178.7 [52.4] 145.7 [42.7] 14.3	171.2 [50.2] 131.0 [38.4] 14.0	165.9 [48.6] 120.4 [35.3] 13.8	173.7 [50.9] 171.6 [50.3] 14.2	166.4 [48.7] 154.2 [45.2] 13.9	161.1 [47.2] 141.8 [41.6] 13.7
	110 [43.3]	Total BTUH [kW] Sens BTUH [kW] Power	184.8 [54.1] 118.0 [34.6] 15.3	177.0 [51.9] 106.1 [31.1] 14.9	171.5 [50.2] 97.6 [28.6] 14.7	173.5 [50.8] 143.2 [42.0] 15.1	166.2 [48.7] 128.7 [37.7] 14.8	161.0 [47.2] 118.3 [34.7] 14.6	168.4 [49.3] 168.4 [49.3] 15.0	161.3 [47.3] 152.0 [44.5] 14.7	156.3 [45.8] 139.7 [40.9] 14.5
	115 [46.1]	Total BTUH [kW] Sens BTUH [kW] Power	179.5 [52.6] 115.6 [33.9] 16.1	172.0 [50.4] 103.9 [30.4] 15.8	166.6 [48.8] 95.5 [28.0] 15.5	168.2 [49.3] 140.7 [41.2] 16.0	161.2 [47.2] 126.5 [37.1] 15.6	156.1 [45.8] 116.3 [34.1] 15.4	163.2 [47.8] 163.2 [47.8] 15.8	156.3 [45.8] 149.8 [43.9] 15.5	151.4 [44.4] 137.7 [40.4] 15.3
	120 [48.9]	Total BTUH [kW] Sens BTUH [kW] Power	174.3 [51.1] 113.3 [33.2] 17.0	167.0 [48.9] 101.8 [29.8] 16.6	161.8 [47.4] 93.6 [27.4] 16.4	163.0 [47.8] 138.4 [40.6] 16.9	156.2 [45.8] 124.4 [36.4] 16.5	151.3 [44.3] 114.4 [33.5] 16.3	157.9 [46.3] 157.9 [46.3] 16.7	151.3 [44.3] 147.7 [43.3] 16.4	146.6 [42.9] 135.8 [39.8] 16.1
	125 [51.7]	Total BTUH [kW] Sens BTUH [kW] Power	169.1 [49.6] 111.0 [32.5] 17.9	162.0 [47.5] 99.8 [29.2] 17.6	156.9 [46.0] 91.7 [26.9] 17.3	157.8 [46.3] 136.1 [39.9] 17.8	151.2 [44.3] 122.4 [35.9] 17.4	146.5 [42.9] 112.5 [33.0] 17.2	152.8 [44.8] 152.8 [44.8] 17.7	146.3 [42.9] 145.6 [42.7] 17.3	141.7 [41.5] 133.9 [39.2] 17.0

DR —Depression ratio
dbE —Entering air dry bulb
wbE—Entering air wet bulb

Total —Total capacity x 1000 BTUH
Sens —Sensible capacity x 1000 BTUH
Power —KW input

NOTES: ① When the entering air dry bulb is other than 80°F [27°C], adjust the sensible capacity from the table by adding $[1.10 \times \text{CFM} \times (1 - \text{DR}) \times (\text{dbE} - 80)]$.

GROSS WATER HEATING CAPACITY—D180

		ENTERING INDOOR AIR @ 80°F [26.7°C] dbE									
wbE		71°F [15.5°C]			67°F [19.4°C]			63°F [19.4°C]			
CFM [L/s]		7200 [3398]	5800 [2737]	4800 [2265]	7200 [3398]	5800 [2737]	4800 [2265]	7200 [3398]	5800 [2737]	4800 [2265]	
O U T L E T W A T E R T E M P E R A T U R E ° F [° C]	75 [23.9]	Total BTUH [kW] Power	145.0 [42.5] 4.2	142.9 [41.9] 4.2	140.3 [41.1] 4.4	140.9 [41.3] 4.2	132.3 [38.8] 5.9	131.9 [38.7] 4.3	141.4 [41.4] 4.2	134.6 [39.4] 4.5	129.3 [37.9] 4.2
	80 [26.7]	Total BTUH [kW] Power	142.8 [41.9] 4.4	140.8 [41.3] 4.4	138.7 [40.6] 4.5	139.0 [40.7] 4.4	130.9 [38.4] 5.7	130.4 [38.2] 4.4	139.5 [40.9] 4.4	133.2 [39.0] 4.7	128.2 [37.6] 4.4
	85 [29.4]	Total BTUH [kW] Power	140.7 [41.2] 4.6	138.7 [40.6] 4.6	137.1 [40.2] 4.7	137.2 [40.2] 4.6	129.4 [37.9] 5.5	128.9 [37.8] 4.6	137.5 [40.3] 4.6	131.8 [38.6] 4.9	127.0 [37.2] 4.6
	90 [32.2]	Total BTUH [kW] Power	138.5 [40.6] 4.8	136.6 [40.0] 4.8	135.5 [39.7] 4.9	135.3 [39.7] 4.8	128.0 [37.5] 5.5	127.4 [37.3] 4.8	135.6 [39.7] 4.8	130.3 [38.2] 5.2	125.9 [36.9] 4.8
	95 [35.0]	Total BTUH [kW] Power	136.4 [40.0] 5.1	134.4 [39.4] 5.1	133.9 [39.2] 5.2	133.4 [39.1] 5.1	126.5 [37.1] 5.5	126.0 [36.9] 5.1	133.7 [39.2] 5.1	128.9 [37.8] 5.4	124.7 [36.5] 5.1
	100 [37.8]	Total BTUH [kW] Power	134.3 [39.4] 5.4	132.3 [38.8] 5.3	132.4 [38.8] 5.4	131.5 [38.5] 5.4	125.1 [36.7] 5.7	124.5 [36.5] 5.4	131.7 [38.6] 5.4	127.5 [37.4] 5.7	123.6 [36.2] 5.4
	105 [40.6]	Total BTUH [kW] Power	132.1 [38.7] 5.7	130.2 [38.2] 5.7	130.8 [38.3] 5.7	129.7 [38.0] 5.7	123.6 [36.2] 6.0	123.0 [36.0] 5.7	129.8 [38.0] 5.7	126.1 [37.0] 6.0	122.4 [35.9] 5.7
	110 [43.3]	Total BTUH [kW] Power	130.0 [38.1] 6.0	128.1 [37.5] 6.0	129.2 [37.9] 6.0	127.8 [37.5] 6.0	122.2 [35.8] 6.3	121.6 [35.6] 6.0	127.9 [37.5] 6.0	124.7 [36.5] 6.4	121.3 [35.5] 6.0
	115 [46.1]	Total BTUH [kW] Power	127.9 [37.5] 6.4	126.0 [36.9] 6.4	127.6 [37.4] 6.4	125.9 [36.9] 6.4	120.7 [35.4] 6.6	120.1 [35.2] 6.4	125.9 [36.9] 6.4	123.3 [36.1] 6.8	120.1 [35.2] 6.4
	120 [48.9]	Total BTUH [kW] Power	125.7 [36.8] 6.8	123.8 [36.3] 6.8	126.0 [36.9] 6.8	124.1 [36.4] 6.8	119.3 [35.0] 7.1	118.6 [34.8] 6.8	124.0 [36.3] 6.8	121.9 [35.7] 7.2	119.0 [34.9] 6.8
125 [51.7]	Total BTUH [kW] Power	123.6 [36.2] 7.3	121.7 [35.7] 7.3	124.4 [36.5] 7.2	122.2 [35.8] 7.3	117.8 [34.5] 7.5	117.2 [34.3] 7.3	122.1 [35.8] 7.3	120.5 [35.3] 7.7	117.8 [34.5] 7.3	

DR —Depression ratio
dbE—Entering air dry bulb
wbE—Entering air wet bulb

Total —Total capacity x 1000 BTUH
Power —KW input

NOTES: ① When the entering air dry bulb is other than 80°F [27°C], adjust the sensible capacity from the table by adding [1.10 x CFM x (1 – DR) x (dbE – 80)].

GROSS WATTS 2ND STAGE kW ADD FOR MIXED MODE OPERATION—D180

		ENTERING INDOOR AIR @ 80°F [26.7°C] dbE								
wbE		71°F [15.5°C]			67°F [19.4°C]			63°F [19.4°C]		
CFM [L/s]		7200 [3398]	5800 [2737]	4800 [2265]	7200 [3398]	5800 [2737]	4800 [2265]	7200 [3398]	5800 [2737]	4800 [2265]
O U T D O O R D R Y B U L B T E M P E R A T U R E ° F [° C]	75 [23.9]	5.9	5.8	5.7	5.8	5.7	5.6	5.8	5.6	5.6
	80 [26.7]	6.1	6.0	5.9	6.1	5.9	5.8	6.0	5.9	5.8
	85 [29.4]	6.4	6.2	6.1	6.3	6.2	6.1	6.2	6.1	6.0
	90 [32.2]	6.6	6.5	6.4	6.6	6.4	6.3	6.5	6.4	6.3
	95 [35.0]	6.9	6.8	6.7	6.9	6.7	6.6	6.8	6.6	6.5
	100 [37.8]	7.3	7.1	7.0	7.2	7.0	6.9	7.1	7.0	6.9
	105 [40.6]	7.6	7.5	7.4	7.5	7.4	7.3	7.5	7.3	7.2
	110 [43.3]	8.0	7.8	7.7	7.9	7.8	7.6	7.8	7.7	7.6
	115 [46.1]	8.4	8.2	8.1	8.3	8.2	8.0	8.3	8.1	8.0
	120 [48.9]	8.9	8.7	8.5	8.8	8.6	8.5	8.7	8.5	8.4
125 [51.7]	9.3	9.1	9.0	9.2	9.1	8.9	9.2	9.0	8.8	

The Kw values in the table are added to the water heating watt values when unit is operating in a mixed mode operation (first stage providing water heating, second stage in cooling mode).

[] Designates Metric Conversions

AIRFLOW PERFORMANCE—15 TON [52.8 kW]—60 HZ — DOWNFLOW

Air Flow CFM [L/s]	Model RLHL-D180 Voltage 208/230, 460 — 3 Phase 60 Hz																																									
	External Static Pressure—Inches of Water [kPa]																																									
	0.1 [0.02]	0.2 [0.05]	0.3 [0.07]	0.4 [0.10]	0.5 [0.12]	0.6 [0.15]	0.7 [0.17]	0.8 [0.20]	0.9 [0.22]	1.0 [0.25]	1.1 [0.27]	1.2 [0.30]	1.3 [0.32]	1.4 [0.35]	1.5 [0.37]	1.6 [0.40]	1.7 [0.42]	1.8 [0.45]	1.9 [0.47]	2.0 [0.50]																						
4800 [2265]	—	—	—	—	—	—	600	1409	629	1536	666	1671	684	1814	711	1964	738	2121	764	2286	790	2459	815	2640	840	2828	865	3023	889	3226	913	3437	—	—	—	—						
5000 [2359]	—	—	—	—	—	—	581	1358	609	1479	637	1608	664	1744	691	1888	718	2040	744	2199	770	2366	795	2541	820	2723	844	2912	869	3109	892	3314	916	3527	—	—	—	—				
5200 [2454]	—	—	—	—	—	—	590	1434	618	1557	645	1688	672	1826	699	1972	725	2125	750	2286	776	2454	800	2630	825	2814	849	3005	873	3204	896	3411	919	3625	—	—	—	—				
5400 [2548]	—	—	—	—	—	—	572	1402	600	1519	627	1644	654	1776	680	1916	706	2063	732	2218	757	2381	782	2551	806	2729	830	2914	854	3107	877	3307	900	3515	922	3731	—	—	—	—		
5600 [2643]	—	—	—	—	—	—	583	1494	610	1613	637	1739	663	1873	689	2014	714	2163	740	2320	764	2484	789	2656	812	2835	836	3022	859	3216	882	3419	904	3628	926	3846	—	—	—	—		
5800 [2737]	—	—	—	—	—	—	594	1594	620	1714	647	1842	672	1978	698	2121	723	2271	747	2430	772	2595	795	2769	819	2950	842	3138	864	3335	887	3538	908	3750	930	3969	—	—	—	—		
6000 [2831]	—	—	—	—	—	—	578	1588	605	1702	631	1824	657	1954	682	2091	707	2236	731	2388	756	2548	779	2715	803	2890	826	3073	848	3263	870	3461	892	3666	913	3879	—	—	—	—		
6200 [2926]	—	—	—	—	—	—	590	1703	616	1819	642	1942	667	2074	692	2212	716	2359	740	2513	764	2674	787	2843	810	3020	833	3204	855	3396	876	3596	897	3803	918	4017	—	—	—	—		
6400 [3020]	—	—	—	—	—	—	577	1716	602	1826	628	1944	653	2069	678	2202	702	2342	726	2490	750	2646	773	2809	796	2980	818	3158	840	3344	861	3538	883	3739	903	3947	924	4164	—	—	—	—
6600 [3114]	—	—	—	—	—	—	589	1846	615	1958	640	2077	665	2204	689	2338	713	2480	736	2630	759	2787	782	2952	804	3124	826	3304	848	3492	869	3687	889	3890	909	4100	929	4318	—	—	—	—
6800 [3209]	577	1878	603	1984	628	2098	652	2219	677	2347	700	2483	724	2627	747	2778	769	2937	791	3104	813	3278	834	3459	855	3648	876	3845	896	4050	916	4262	—	—	—	—	—	—	—	—		
7000 [3303]	591	2023	616	2131	641	2246	665	2368	689	2499	712	2636	735	2782	757	2935	779	3095	801	3263	822	3439	843	3622	864	3813	884	4012	903	4218	923	4431	—	—	—	—	—	—	—	—		
7200 [3398]	606	2177	630	2286	654	2402	678	2527	701	2659	724	2798	746	2945	768	3099	790	3262	811	3431	832	3609	852	3794	872	3986	892	4186	911	4394	930	4609	—	—	—	—	—	—	—	—		

NOTE: L-Drive left of bold line, M-Drive right of bold line.

Drive Package	L	M
Motor H.P. [W]	3 [2237.1]	5 [2237.1]
Blower Sheave	BK105H	BK105H
Motor Sheave	1VP-44	1VP-56
Turns Open	1 2 3 4 5 6	1 2 3 4 5 6
RPM	732 701 670 642 608 575	896 866 836 805 774 744

- NOTES: 1. Factory sheave settings are shown in bold type.
 2. Do not set motor sheave below minimum or maximum turns open shown.
 3. Re-adjustment of sheave required to achieve rated airflow at AHRI minimum External Static Pressure
 4. Add component resistance (below) to duct resistance to determine total External Static Pressure.

Airflow CFM [L/s]	AIRFLOW CORRECTION FACTORS*				Power kW	COMPONENT AIRFLOW RESISTANCE				
	Sensible MBH		Wet Coil			Downflow Economizer RA Damper Open	Concentric Grill RXRN-AD80 or RXRN-AD81 & Transition RXMC-CJ07		Concentric Grill RXRN-AD86 & Transition RXMC-CK08	
	Total MBH	Power kW	Resistance — Inches of Water [kPa]	Resistance — Inches of Water [kPa]			Resistance — Inches of Water [kPa]	Resistance — Inches of Water [kPa]		
4800 [2265]	0.97	0.92	0.98	0.03 [0.01]	0.09 [0.02]	—	—	—	—	—
5000 [2359]	0.97	0.94	0.99	0.04 [0.01]	0.10 [0.02]	—	—	—	—	—
5200 [2454]	0.98	0.95	0.99	0.05 [0.01]	0.10 [0.02]	—	—	—	—	—
5400 [2548]	0.99	0.97	0.99	0.06 [0.01]	0.11 [0.03]	—	—	—	—	—
5600 [2643]	0.99	0.98	0.99	0.06 [0.01]	0.12 [0.03]	0.35 [0.09]	0.39 [0.10]	—	—	—
5800 [2737]	1.00	1.00	1.00	0.07 [0.02]	0.13 [0.03]	0.43 [0.11]	—	—	—	—
6000 [2831]	1.01	1.02	1.00	0.08 [0.02]	0.13 [0.03]	0.46 [0.11]	—	—	—	—
6200 [2926]	1.01	1.03	1.00	0.09 [0.02]	0.14 [0.03]	0.50 [0.12]	—	—	—	—
6400 [3020]	1.02	1.05	1.01	0.10 [0.02]	0.15 [0.04]	0.54 [0.13]	—	—	—	—
6600 [3114]	1.02	1.06	1.01	0.10 [0.02]	0.16 [0.04]	—	—	—	—	—
6800 [3209]	1.03	1.08	1.01	0.11 [0.03]	0.16 [0.04]	—	—	—	—	—
7000 [3303]	1.04	1.10	1.01	0.12 [0.03]	0.17 [0.04]	—	—	—	—	—
7200 [3398]	1.04	1.11	1.02	0.13 [0.03]	0.18 [0.04]	—	—	—	—	0.38 [0.09]

*Multiply correction factor times gross performance data — resulting sensible capacity cannot exceed total capacity.

[] Designates Metric Conversions

ELECTRICAL DATA – RLHL- SERIES

		D180CL	D180CM	D180DL	D180DM
Unit Information	Unit Operating Voltage Range	187-253	187-253	414-506	414-506
	Volts	208/230	208/230	460	460
	Minimum Circuit Ampacity	77/77	81/81	40	42
	Minimum Overcurrent Protection Device Size	90/90	90/90	45	45
	Maximum Overcurrent Protection Device Size	100/100	100/100	50	50
Compressor Motor	No.	2	2	2	2
	Volts	200/230	200/230	460	460
	Phase	3	3	3	3
	RPM	3450	3450	3450	3450
	HP, Compressor 1	7 1/2	7 1/2	7 1/2	7 1/2
	Amps (RLA), Comp. 1	25/25	25/25	12.8	12.8
	Amps (LRA), Comp. 1	164/164	164/164	100	100
	HP, Compressor 2	7 1/2	7 1/2	7 1/2	7 1/2
	Amps (RLA), Comp. 2	25/25	25/25	12.8	12.8
Amps (LRA), Comp. 2	164/164	164/164	100	100	
Condenser Motor	No.	3	3	3	3
	Volts	208/230	208/230	460	460
	Phase	1	1	1	1
	HP	1/3	1/3	1/3	1/3
	Amps (FLA, each)	2.4/2.4	2.4/2.4	1.4	1.4
	Amps (LRA, each)	4.7/4.7	4.7/4.7	2.4	2.4
Evaporator Fan	No.	1	1	1	1
	Volts	208/230	208/230	460	460
	Phase	3	3	3	3
	HP	3	5	3	5
	Amps (FLA, each)	11.5/11.5	14.9/14.9	4.6	6.6
	Amps (LRA, each)	74.5/74.5	95/95	38.1	47.5
Water Pump	No.	1	1	1	1
	Volts	208/230	208/230	208/230	208/230
	Phase	1	1	1	1
	HP	1/3	1/3	1/3	1/3
	Amps (FLA, each)	1.7	1.7	1.7	1.7
	Amps (LRA, each)	5.1	5.1	5.1	5.1

208/240 VOLT, THREE PHASE, 60 HZ, AUXILIARY ELECTRIC HEATER KITS CHARACTERISTICS AND APPLICATION																
Separate Power Supply for Both Unit and Heater Kit																
Model No. RLHL-	Single Power Supply for Both Unit and Heater Kit				Air Conditioner				Heater Kit				Air Conditioner			
	RXJJ-Heater Kit Nominal kW	No. of Sequence Steps	Rated Heater kW @ 208/240V	Heater kBTU/Hr @ 208/240V	Heater Amps @ 208/240V	Unit Min. Ckt. Ampacity @ 208/240V	Over Current Protective Device Size		Min. Ckt. Ampacity 208/240V	Max. Fuse Size 208/240V	Min. Circuit Ampacity 208/240V	Over Current Protective Device Size				
							Min./Max. 208V	Min./Max. 240V				Min./Max. 208V	Min./Max. 240V			
D180CL	No Heat	—	—	—	—	77/77	90/100	90/100	—	—	77/77	90/100	90/100			
	CE20C	1	14.4/19.2	49.13/65.5	40/46.2	77/77	90/100	90/100	50/58	50/60	77/77	90/100	90/100			
	CE40C	2	28.8/38.3	98.25/130.66	79.9/92.2	117/132	125/125	150/150	100/116	100/125	77/77	90/100	90/100			
	CE60C	2	43.2/57.5	147.38/196.16	119.9/138.3	167/190	175/175	200/200	150/173	150/175	77/77	90/100	90/100			
D180CM	CE75C	2	54/71.9	184.22/245.29	149.8/172.8	204/233	225/225	250/250	188/217	200/225	77/77	90/100	90/100			
	No Heat	—	—	—	—	81/81	90/100	90/100	—	—	81/81	90/100	90/100			
	CE20C	1	14.4/19.2	49.13/65.5	40/46.2	81/81	90/100	90/100	50/58	50/60	81/81	90/100	90/100			
	CE40C	2	28.8/38.3	98.25/130.66	79.9/92.2	121/136	125/125	150/150	100/116	100/125	81/81	90/100	90/100			
D180DM	CE60C	2	43.2/57.5	147.38/196.16	119.9/138.3	171/194	175/175	200/200	150/173	150/175	81/81	90/100	90/100			
	CE75C	2	54/71.9	184.22/245.29	149.8/172.8	209/237	225/225	250/250	188/217	200/225	81/81	90/100	90/100			

480 VOLT, THREE PHASE, 60 HZ, AUXILIARY ELECTRIC HEATER KITS CHARACTERISTICS AND APPLICATION																
Separate Power Supply for Both Unit and Heater Kit																
Model No. RLHL-	Single Power Supply for Both Unit and Heater Kit				Air Conditioner				Heater Kit				Air Conditioner			
	RXJJ-Heater Kit Nominal kW	No. of Sequence Steps	Rated Heater kW @ 480V	Heater kBTU/Hr @ 480V	Heater Amps @ 480V	Unit Min. Ckt. Ampacity @ 480V	Over Current Protective Device Size		Min. Ckt. Ampacity 480V	Max. Fuse Size 480V	Min. Circuit Ampacity 480V	Over Current Protective Device Size				
							Min./Max. 480V	Min./Max. 480V				Min./Max. 480V	Min./Max. 480V			
D180DL	No Heat	—	—	—	—	40	45/50	45/50	—	—	40	45/50	45/50			
	CE20D	1	19.2	65.5	23.1	40	45/50	45/50	29	30	40	45/50	45/50			
	CE40D	2	38.4	131	46.2	66	70/70	70/70	58	60	40	45/50	45/50			
	CE60D	2	57.6	196.5	69.3	95	100/100	100/100	87	90	40	45/50	45/50			
D180DM	CE75D	2	72	245.63	86.6	117	125/125	125/125	109	110	40	45/50	45/50			
	No Heat	—	—	—	—	42	45/50	45/50	—	—	42	45/50	45/50			
	CE20D	1	19.2	65.5	23.1	42	45/50	45/50	29	30	42	45/50	45/50			
	CE40D	2	38.4	131	46.2	69	70/70	70/70	58	60	42	45/50	45/50			
D180DM	CE60D	2	57.6	196.5	69.3	98	100/100	100/100	87	90	42	45/50	45/50			
	CE75D	2	72	245.63	86.6	119	125/125	125/125	109	110	42	45/50	45/50			

*= For Canadian use only. Uses "P" fuses for inductive circuit.
+ = Field installed only.

PACKAGE AIR CONDITIONER DOWNFLOW ONLY

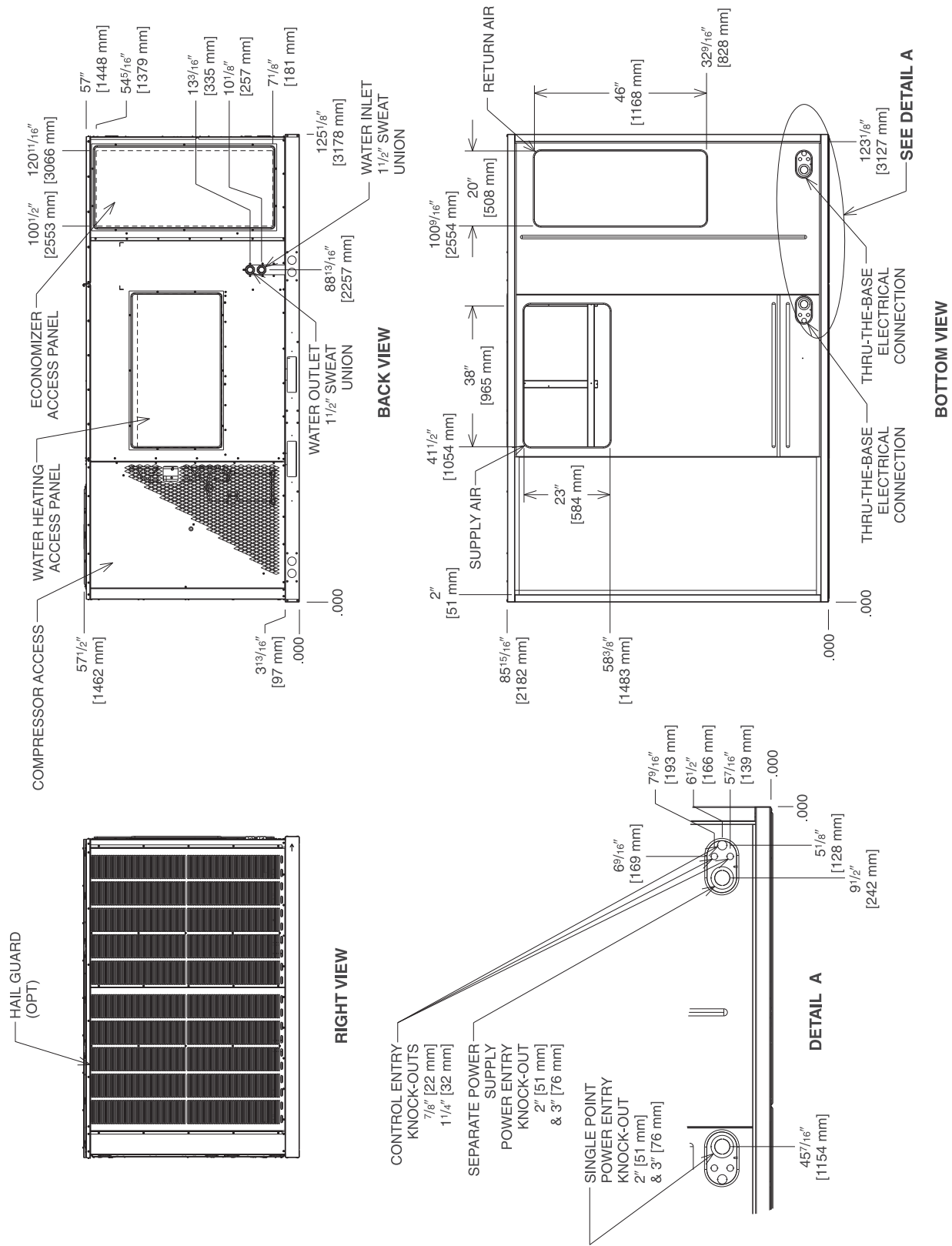

[] Designates Metric Conversions

GAS HEAT / ELECTRIC COOLING PACKAGE DOWNFLOW ONLY

BOTTOM VIEW

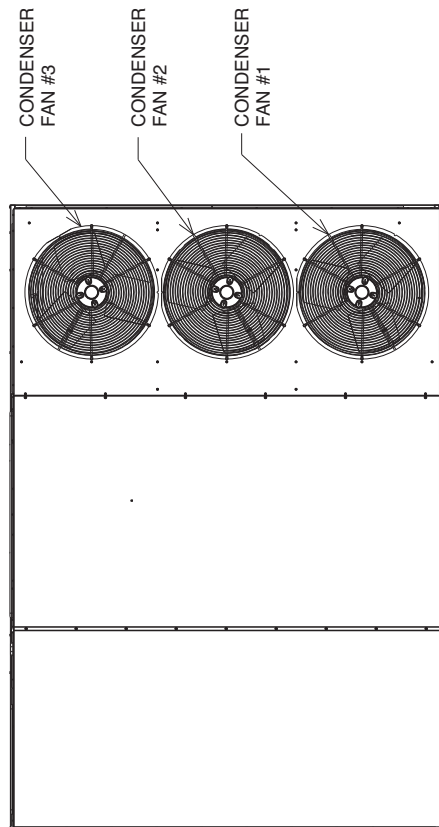

TOP VIEW

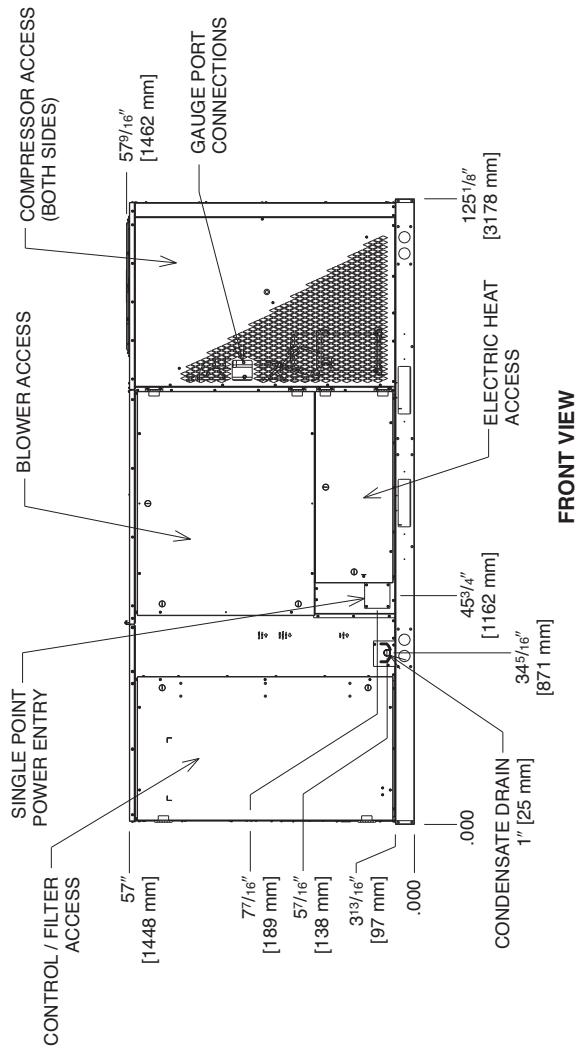

FRONT VIEW

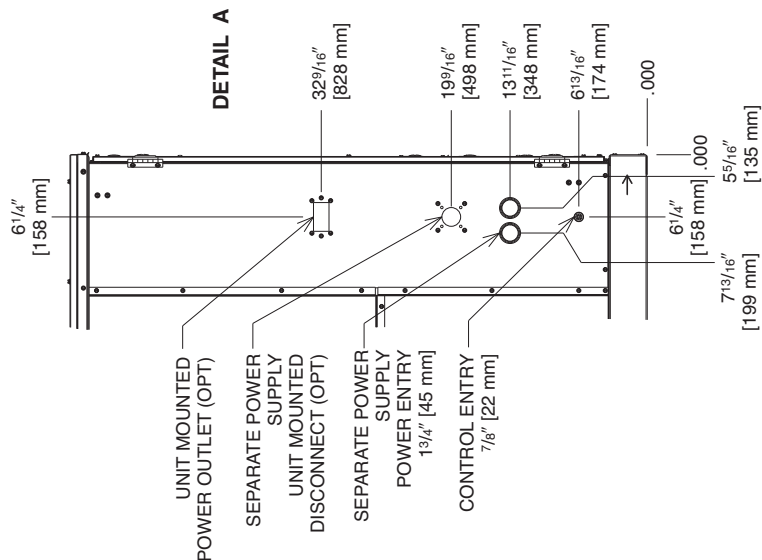

DETAIL A

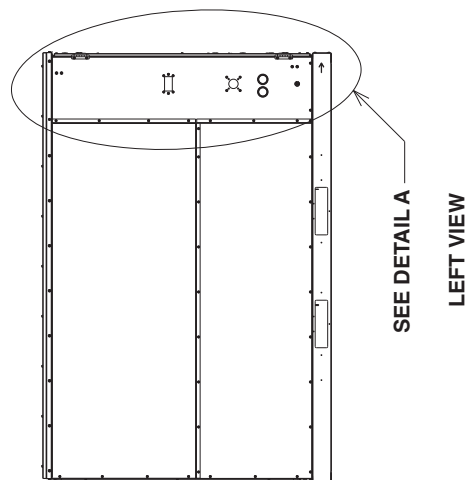

LEFT VIEW

[] Designates Metric Conversions

Illustration
SI-A1207-10

WEIGHTS

Accessory	Shipping—Lbs. [kg]	Operating—Lbs. [kg]
Economizer	277 [125.6]	168 [76.2]
Power Exhaust	119 [54.0]	59 [26.8]
Manual Fresh Air Damper*	61 [27.7]	52 [23.6]
Motor Kit for Fresh Air Damper	42 [19.1]	35 [15.9]
Roofcurb, 14"	184 [83.5]	176 [79.8]
Hail Guard Louvers	55 [24.8]	45 [20.3]

Capacity Tons [kW]	Corner Weights by Percentage			
	A	B	C	D
15 [52.8]	26%	29%	18%	27%

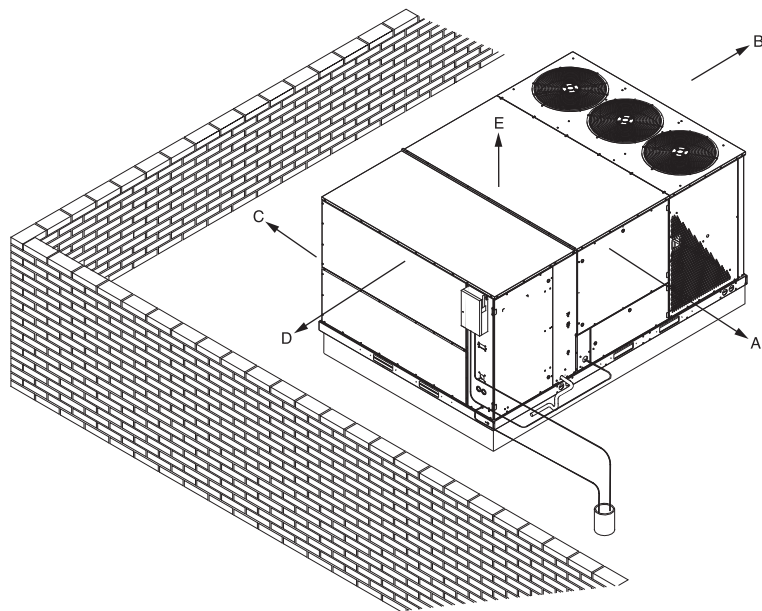
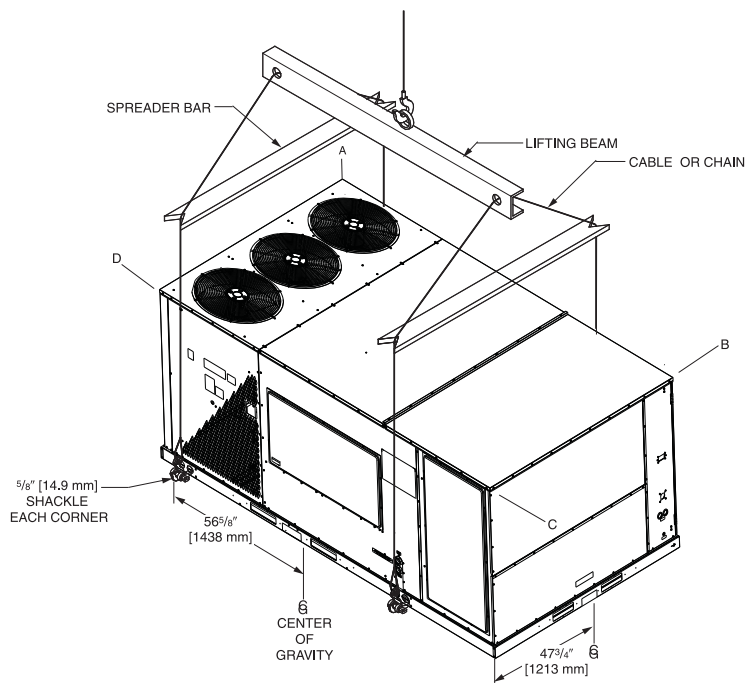

CLEARANCES

The following minimum clearances must be observed for proper unit performance and serviceability.

Recommended Clearance In. [mm]	Location
80 [2032]	A - Front
18 [457]	B - Condenser Coil
18 [457]	C - Duct Side
18 [457]*	D - Evaporator End
60 [1524]	E - Above

*Without Economizer. 48" [1219 mm] With Economizer

Illustration
ST-A1207-13

[] Designates Metric Conversions

FIELD INSTALLED ACCESSORY EQUIPMENT

Accessory	Model Number	Shipping Weight Lbs. [kg]	Installed Weight Lbs. [kg]	Factory Installation Available?
Thermostats	See Thermostat Specification Sheet for Details (T22-001)			No
Electric Heaters	RXJJ-CE20 (C,D)	41 [18.6]	31 [14.1]	Yes
	RXJJ-CE40 (C,D)	44 [20.0]	34 [15.4]	Yes
	RXJJ-CE60 (C,D)	45 [20.4]	35 [15.9]	Yes
	RXJJ-CE75 (C,D)	46 [20.8]	36 [16.3]	Yes
Economizer - Single Enthalpy (DDC)	AXRD-PMCM3	277 [125.6]	168 [76.2]	Yes
Dual Enthalpy Kit (DDC)	RXR- AV03	1 [.5]	1 [.5]	No
Economizer-Single Enth/ Smoke Detector (DDC)	AXRD-SMCM3	280 [127.0]	171 [77.6]	Yes
Carbon Dioxide Sensor (Wall Mount)	RXR- AR02	3 [1.4]	2 [1.0]	No
Power Exhaust (208/230V)	RXR- BGF05C	119 [54.0]	59 [26.8]	No
Power Exhaust (460V)	RXR- BGF05D	119 [54.0]	59 [26.8]	No
Manual Fresh Air Damper*	AXRF-KFA1	61 [27.7]	52 [23.6]	No
Motor Kit for AXRF-KFA1 Fresh Air Damper	RXR- AW03	42 [19.1]	35 [15.9]	No
Modulating Mtr Kit w/ Feedback for RXRF-KFA1*	RXR- AW05	45 [20.4]	38 [17.2]	No
Roofcurb, 14"	RXKG-CBH14	184 [83.5]	176 [79.8]	No
Roofcurb Adapter to RXRK-E56	RXR- CJCE56	465 [210.9]	415 [88.2]	No
Roofcurb Adapter to RXKG-CAF14	RXR- CJCF14	555 [251.7]	505 [29.1]	No
Concentric Diffuser (Step-Down, 18" x 36")	RXRN-AD81	310 [140.6]	157 [71.2]	No
Concentric Diffuser (Flush, 18" x 36")	RXRN-AD80	213 [96.6]	115 [52.2]	No
Downflow Transition (Rect. to Rect., 18" x 36")	RXMC-CJ07	81 [36.7]	74 [33.6]	No
Low-Ambient Control Kit (1 Per Compressor)	RXRZ-C02	3 [1.4]	2 [1.0]	Yes
Unwired Convenience Outlet	RXR- AN01	2 [1.0]	1.5 [.7]	Yes
Comfort Alert (1 Per Compressor)	RXR- AZ01	3 [1.5]	2 [0.9]	Yes
BACnet Communication Card	RXR- AY01	1 [0.5]	1 [0.5]	No
LonWorks Communication Card	RXR- AY02	1 [0.5]	1 [0.5]	No
Hail Guard Louvers	AXRX-AAD01K	55 [24.8]	45 [20.3]	Yes
Commercial Storage Tank	ST120	300 [136.1]	1240 [562.5]	No
Flush valve kit for eSYNC™ Unit	RXMV-AG	12 [5.4]	11 [5.0]	No
Emergency Electrically Operated Water Shutoff Valve	RXMV-AH	12 [5.4]	11 [5.0]	No
Water Storage Tank Kit	RXMZ-A120A	32 [14.5]	30 [13.6]	No

* Motorized Kit and Manual Fresh Air Damper must be combined for a complete Motorized Outside Air Damper Selection.

[] Designates Metric Conversions



200-Series *
Programmable



300-Series *
Deluxe
Programmable



500-Series *
Communicating/
Programmable

400-Series *
Special Applications/
Programmable

Brand	Descriptor (3 Characters)	Series (3 Characters)	System (2 Characters)	Type (2 Characters)
UHC	- TST	213	UN	MS
UHC=Ruud	TST=Thermostat	200=Programmable 300=Deluxe Programmable 400=Special Applications/ Programmable 500=Communicating/ Programmable	GE=Gas/Electric UN=Universal (AC/HP/GE) MD=Modulating Furnace DF=Dual Fuel CM=Communicating	SS=Single-Stage MS=Multi-Stage

* Photos are representative. Actual models may vary.

For detailed thermostat match-up information,
see specification sheet form number T22-001.

FLUSH MOUNT ROOM TEMPERATURE SENSORS FOR NETWORKED DDC APPLICATIONS



ROOM TEMPERATURE SENSOR RHC-ZNS1 with TIMED OVERRIDE BUTTON

10k Ω room temperature sensor transmits room temperature to DDC system. Timed override button allows tenant to change from unoccupied temperature setpoint to occupied temperature setpoint for a preset time.

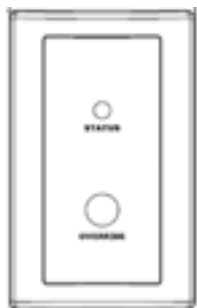

ROOM TEMPERATURE SENSOR RHC-ZNS2 with TIMED OVERRIDE BUTTON and STATUS INDICATOR

10k Ω room temperature sensor transmits room temperature to DDC system. Timed override button allows tenant to change from unoccupied temperature setpoint to occupied temperature setpoint for a preset time. Status Indicator Light transmits ALARM flash code to occupied space.



ROOM TEMPERATURE SENSOR RHC-ZNS3 with SETPOINT ADJUSTMENT and TIMED OVERRIDE BUTTON

10k Ω room temperature sensor with setpoint adjustment transmits room temperature to DDC system along with desired occupied room temperature setpoint. Timed override button allows tenant to change from unoccupied temperature setpoint to occupied temperature setpoint for a preset time.

COMMUNICATION CARDS Field Installed



BACnet® COMMUNICATION CARD RXRX-AY01

The field installed BACnet® Communication Card allows the RTU-C unit controller to communicate with a third party building management system that supports the BACnet Application Specific Controller device profile. The BACnet® Communication Module plugs onto the unit RTU-C controller and allows communication between the RTU-C and the BACnet MSTP network.



LonWorks® COMMUNICATION CARD RXRX-AY02

The field installed LonWorks® Communication Card allows the RTU-C unit controller to communicate with a third party building management system that supports the LonMark Space Comfort Controller (SCC) functional profile or LonMark Discharge Air Controller (DAC) functional profile. The LonMark Communication Module plugs onto the RTU-C controller and allows communication between the RTU-C and a LonWorks Network.

ECONOMIZERS—DOWNFLOW ONLY

Field Installed

AXRD-PMCM3—Single Enthalpy (Outdoor) with DDC

AXRD-SMCM3—Single Enthalpy (Outdoor) w/Smoke Detector and DDC

RXR-AR02—Optional Wall-Mounted CO₂ Sensor

RXR-AV03—Dual Enthalpy Upgrade Kit

- Features **Honeywell** Controls
- Available Factory Installed or Field Accessory
- Gear Driven Direct Drive Actuator
- Fully Modulating (0-100%)
- Low Leakage Dampers
- Slip-In Design for Easy Installation
- Plug-In Polarized 12-pin & 4-pin Electrical Connections
- Pre-Configured—No Field Adjustments Necessary
- Standard Barometric Relief Damper
- Single Enthalpy with Dual Enthalpy Upgrade Kit Available
- CO₂ Input Sensor Available
- Field Assembled Hood Ships with Economizer
- Economizer Ships Complete for Downflow Duct Application.
- Optional Remote Minimum Position Potentiometer (270 ohm) (Honeywell #S963B1136) is Available from Prostock.
- Field Installed Power Exhaust Available
- If connected to a Building Automation System (BAS), all economizer functions can be viewed on the (BAS).

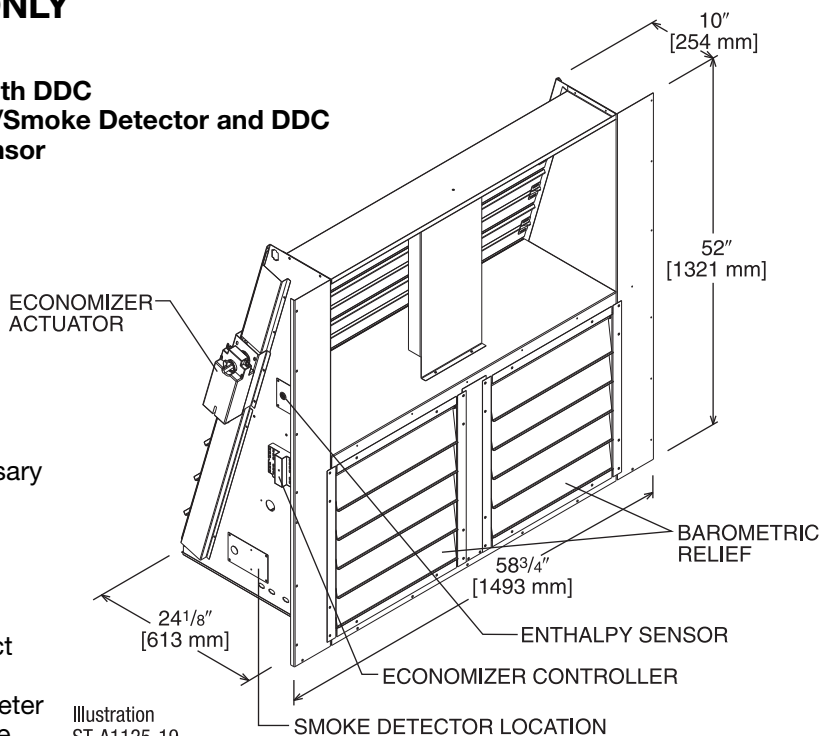

Illustration
ST-A1125-19

TOLERANCE ±.125

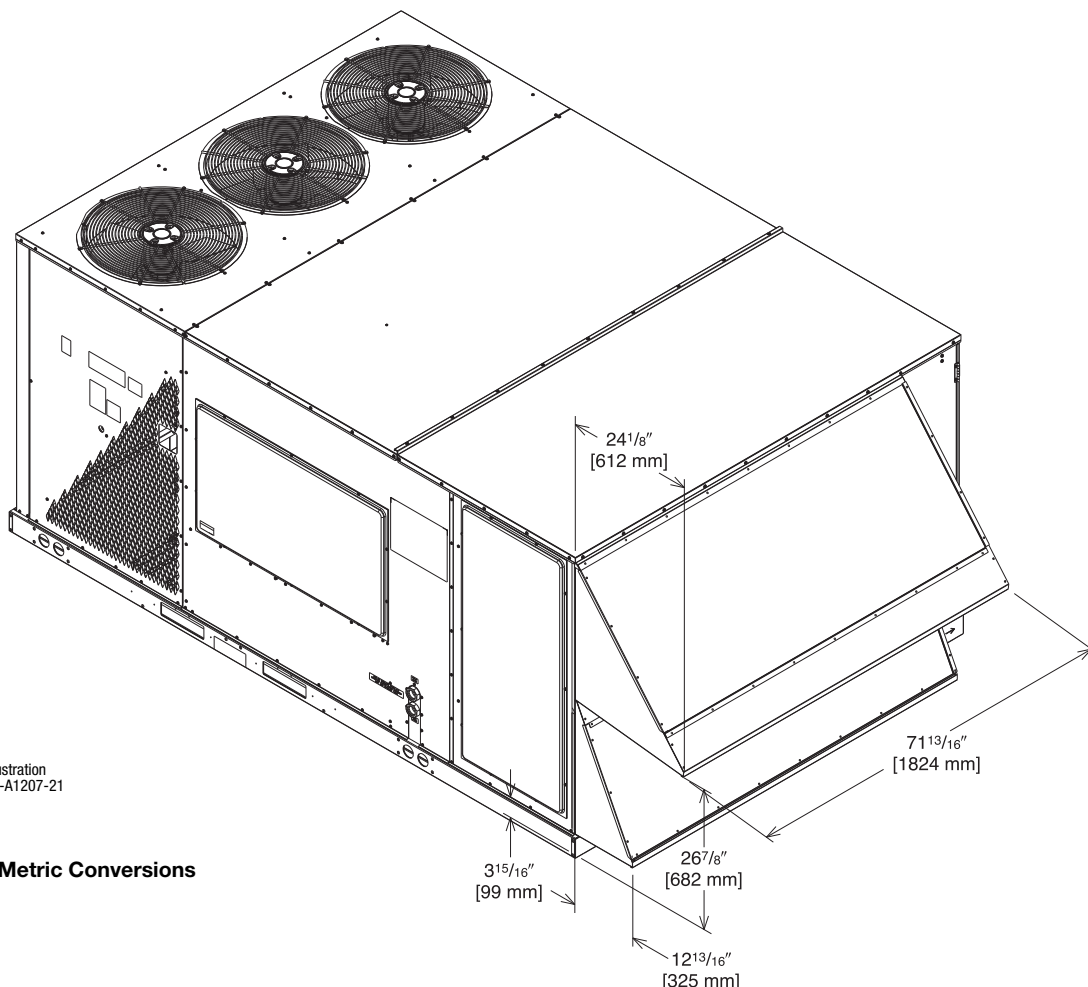

Illustration
ST-A1207-21

[] Designates Metric Conversions

INTEGRAL POWER EXHAUST KIT FOR AXRD-PMCM3 OR SMCM3 ECONOMIZERS

RXRX-BGF05 (C, D*)

*Voltage Code

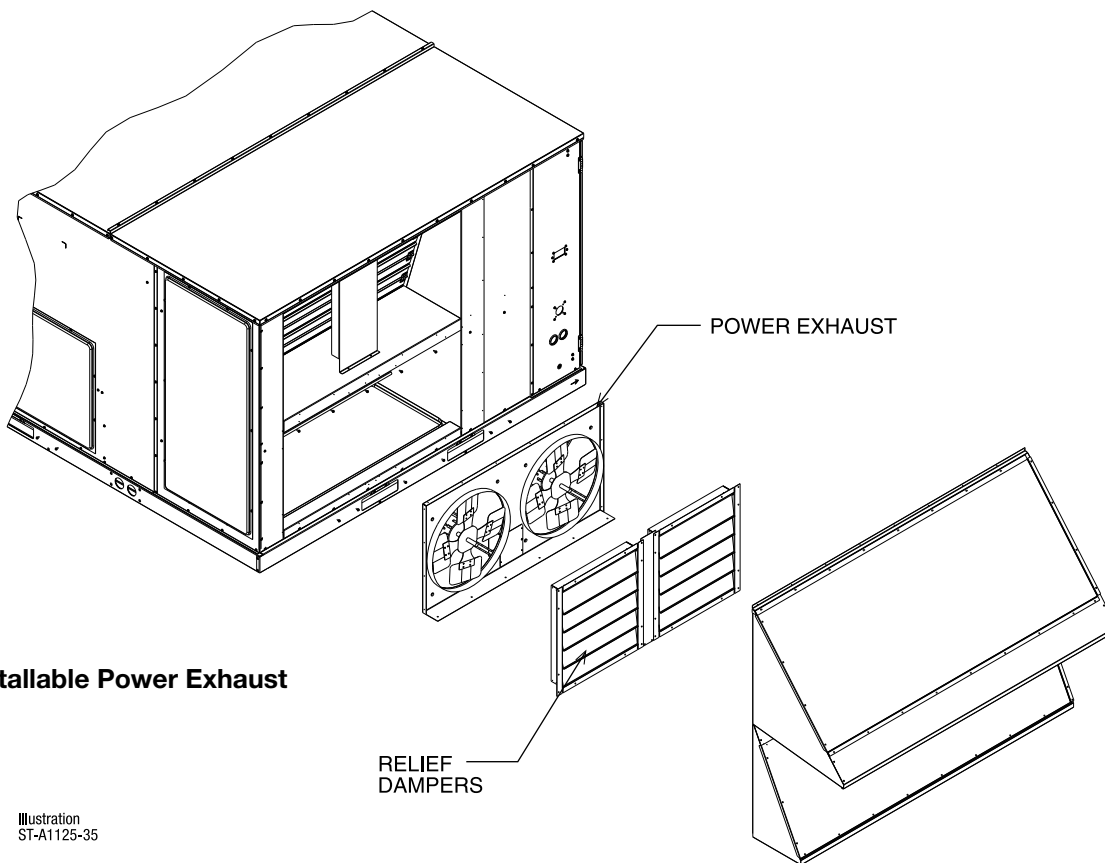

Field Installable Power Exhaust

Illustration
ST-A1125-35

Model No.	No. of Fans	Volts	Phase	HP (ea.)	Low Speed		High Speed ①		FLA (ea.)	LRA (ea.)
					CFM [L/s] ②	RPM	CFM [L/s] ②	RPM		
RXRX-BGF05C	2	208-230	1	0.75	4100 [1935]	850	5200 [2454]	1050	5	4.97
RXRX-BGF05D	2	460	1	0.75	4100 [1935]	850	5200 [2454]	1050	2.2	3.4

NOTES: ① Power exhaust is factory set on high speed motor tap.

② CFM is per fan at 0" w.c. external static pressure.

[] Designates Metric Conversions

FRESH AIR DAMPER

MOTORIZED DAMPER KIT RXRX-AW03 (Motor Kit for AXRF-KFA1)

RXRX-AW05 (Modulating Motor Kit with position feedback for AXRF-KFA1)

- Features **Honeywell** Controls
- Gear Driven Direct Drive Actuator
- Fully Modulating (0-100%)
- Low Leakage Dampers
- Slip-In Design for Easy Installation
- Plug-In Polarized 12-pin and 4-pin Electrical Connections
- Pre-Configured—No Field Adjustments Necessary
- Addition of Dual Enthalpy Upgrade Kit allows limited economizer function
- CO₂ Sensor Input Available for Demand Control Ventilation (DCV)
- Optional Remote Minimum Position Potentiometer (270 ohm) (Honeywell #S963B1136) is available from Prostock
- All fresh air damper functions can be viewed at the RTU-C unit controller display
- If connected to a Building Automation System (BAS), all fresh air damper functions can be viewed on the (BAS), or on the 16 x 2 LCD screen
- If connected to thermostat, all fresh air damper functions can be viewed on 16 x 2 LCD screen

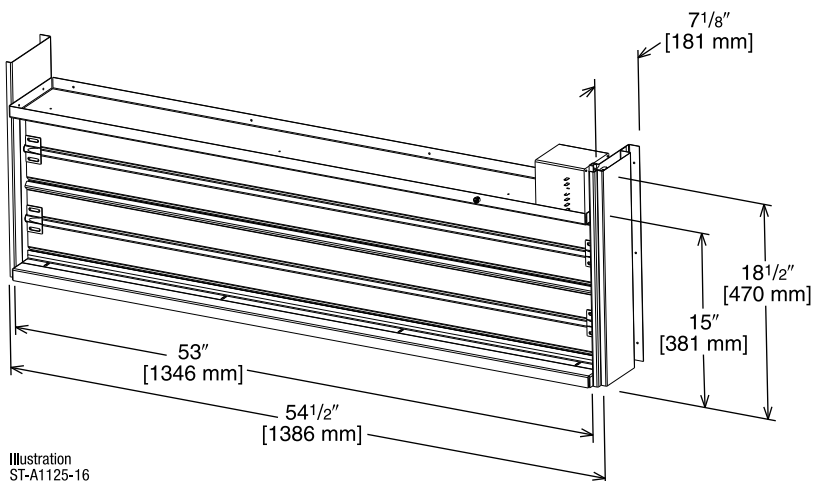

Illustration
ST-A1125-16

AXRF-KFA1 (Manual)

RXRX-AW03 (Motorized damper kit for manual fresh air damper)

RXRX-AW05 (Modulating Motor Kit with position feedback for AXRF-KFA1)

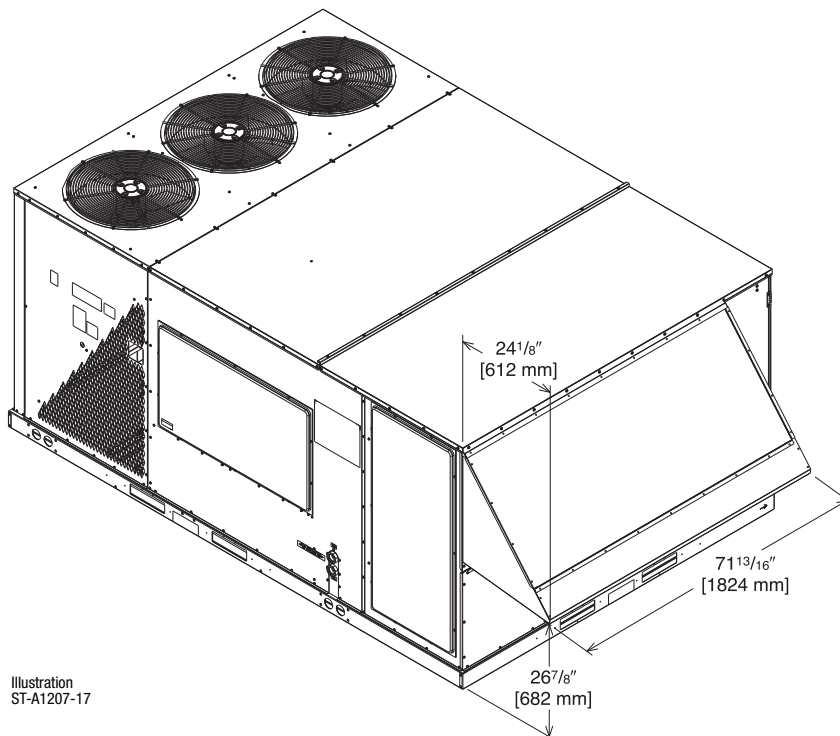
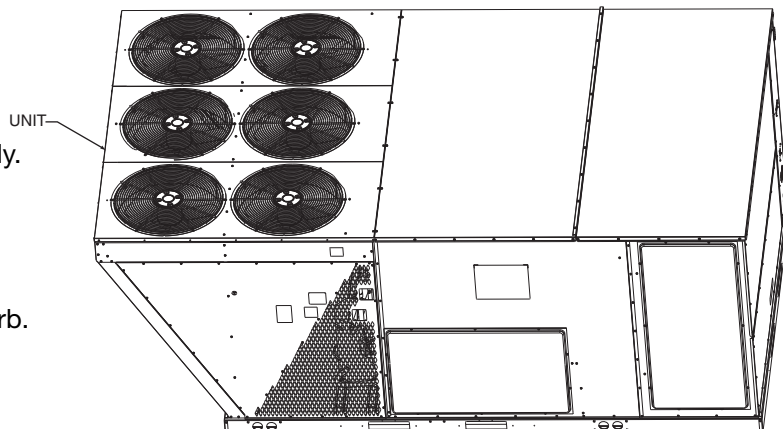

Illustration
ST-A1207-17

[] Designates Metric Conversions

ROOFCURBS (Full Perimeter)

- Ruud's roofcurb design can be utilized on 15 and 20 ton [52.8 and 70.3 kW] models.
- One available height (14" [356 mm]).
- Quick assembly corners for simple and fast assembly.
- 1" [25.4 mm] x 4" [102 mm] Nailers provided.
- Insulating panels not required because of insulated outdoor base pan.
- Sealing gasket (28" [711 mm]) provided with Roofcurb.
- Packaged for easy field assembly.



ROOFCURB ASSEMBLY

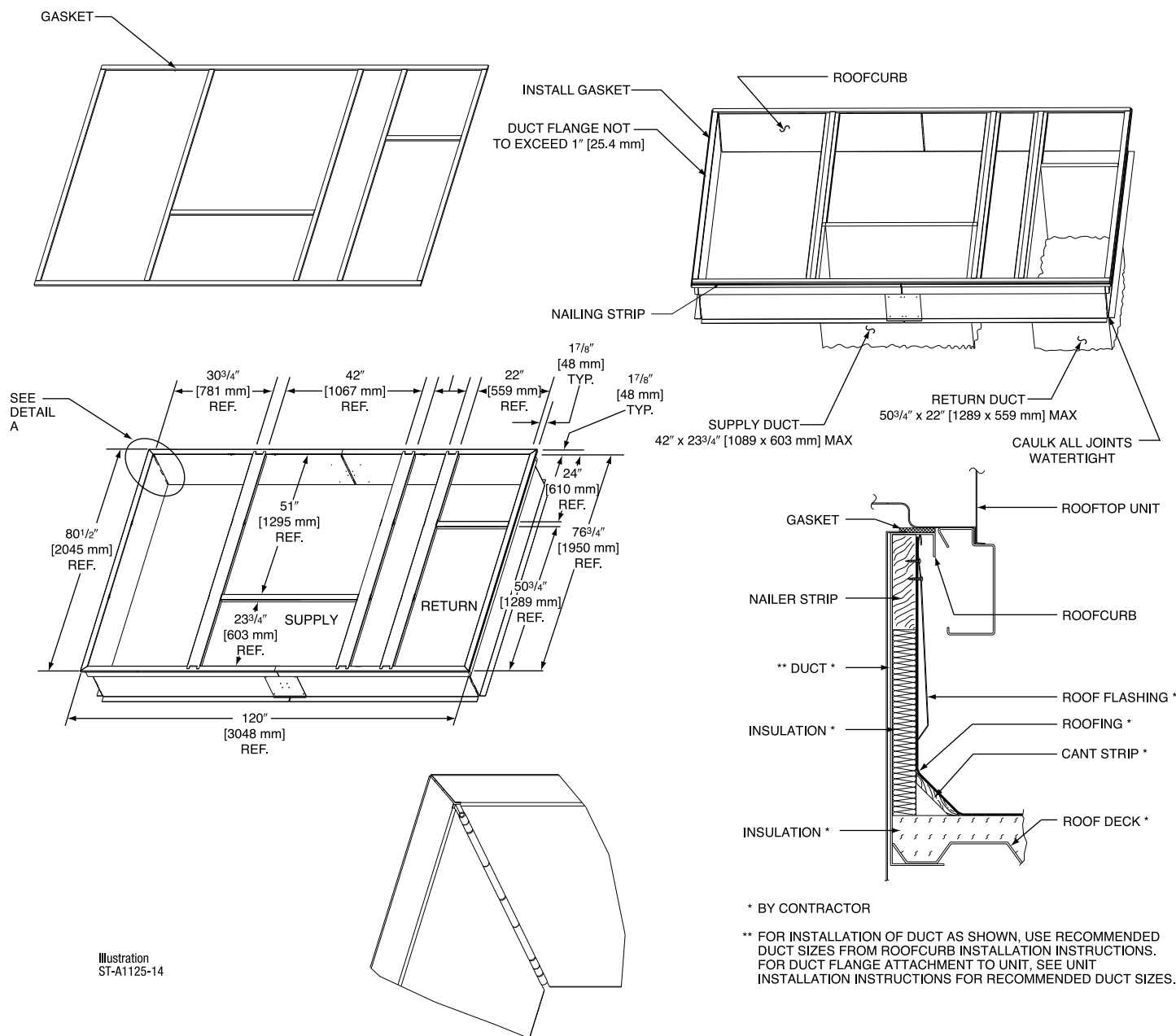

* BY CONTRACTOR

** FOR INSTALLATION OF DUCT AS SHOWN, USE RECOMMENDED DUCT SIZES FROM ROOFCURB INSTALLATION INSTRUCTIONS. FOR DUCT FLANGE ATTACHMENT TO UNIT, SEE UNIT INSTALLATION INSTRUCTIONS FOR RECOMMENDED DUCT SIZES.

[] Designates Metric Conversions

DETAIL A

ROOFCURB ADAPTERS

OLD MODELS

OLD CURB MODEL

ROOFCURB ADAPTER

NEW MODEL

COMMERCIAL CABINET
(12.5, 15 & 20 TON)
([44, 52.8 & 70.3 kW])
(-)RCF, (-)RGF, (-)REF

RXRK-E56

RXRK-CJCE56

RLHL-D
(15 TON)
([52.8 kW])

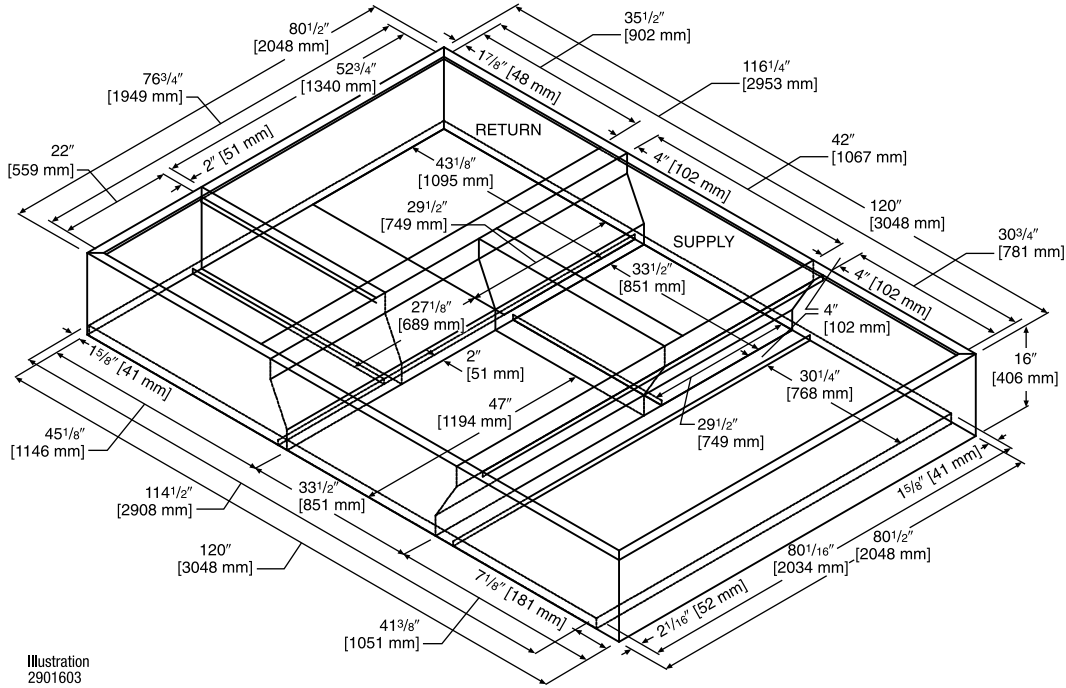

COMMERCIAL CABINET
(15, 20 & 25 TON)
([52.8, 70.3 & 87.9 kW])
(-)LKB, LMB, LNB

RXKG-CAF14

RXRK-CJCF14

RLHL-D
(15 TON)
([52.8 kW])

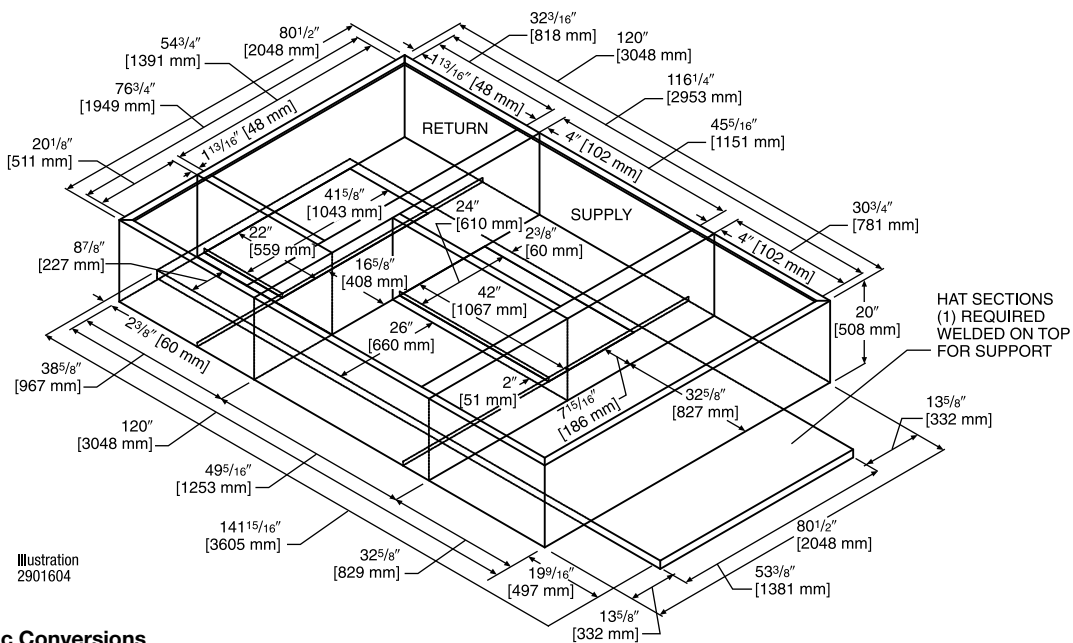

[] Designates Metric Conversions

CONCENTRIC DIFFUSER APPLICATION

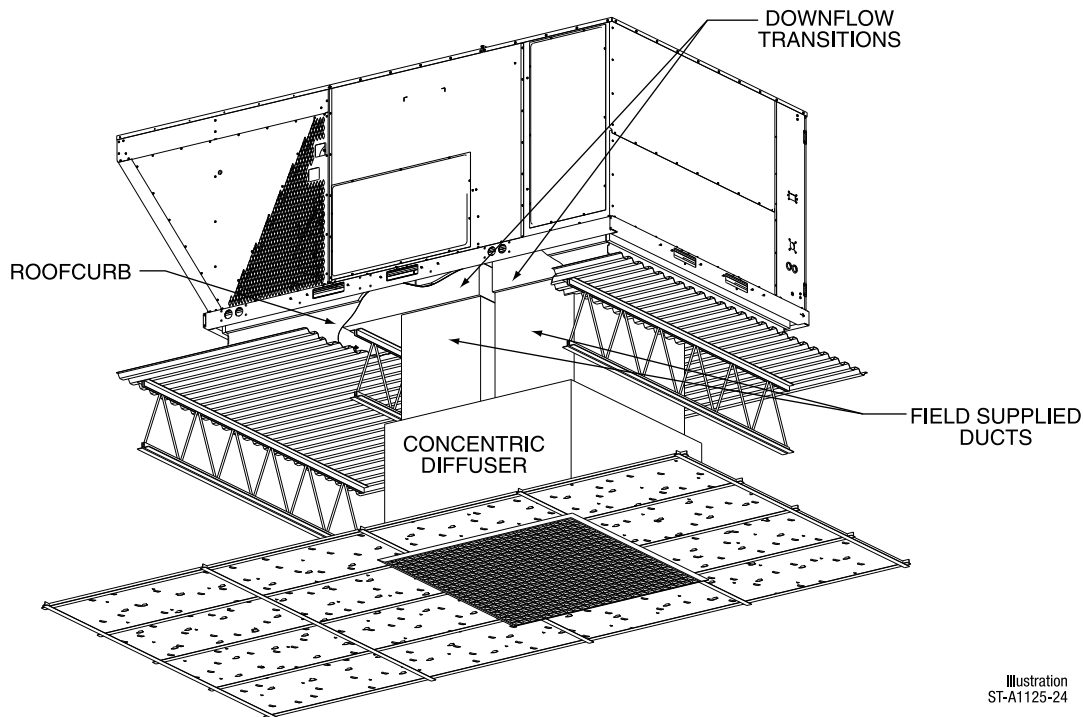

Illustration
ST-A1125-24

DOWNFLOW TRANSITION DRAWINGS

RXMC-CJ07 (15 Ton) [52.8 kW]

- Used with RXRN-AD80 and RXRN-AD81 Concentric Diffusers.

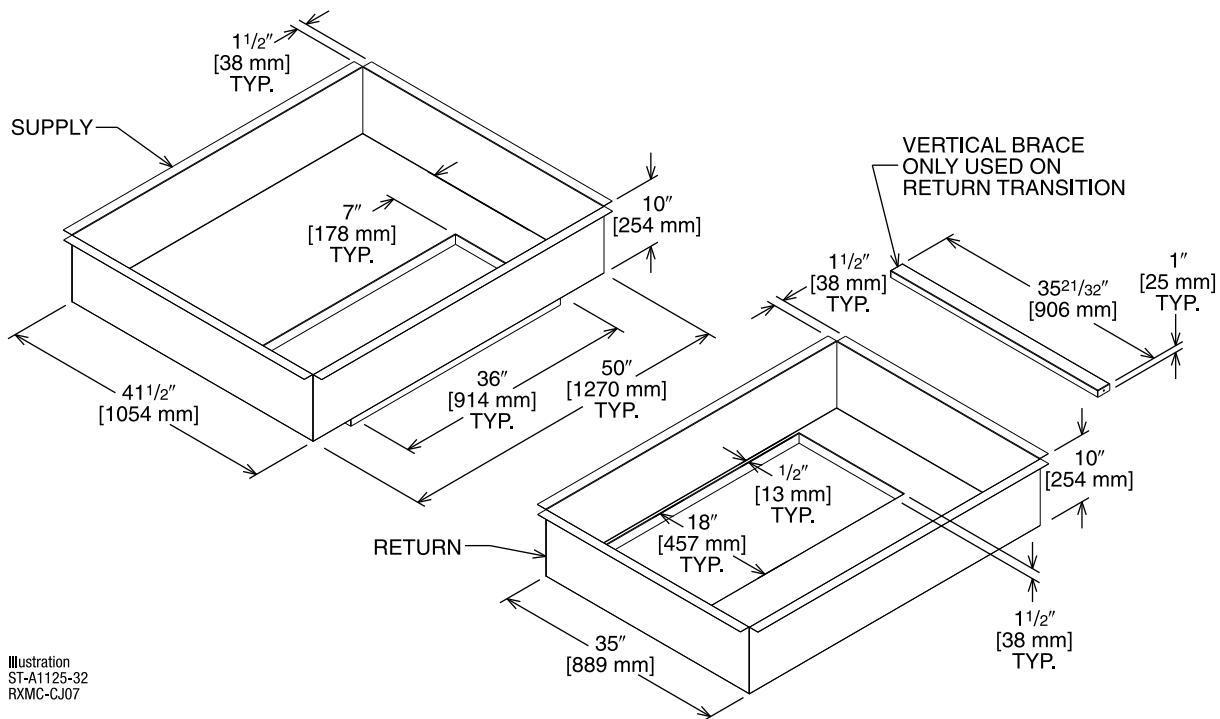
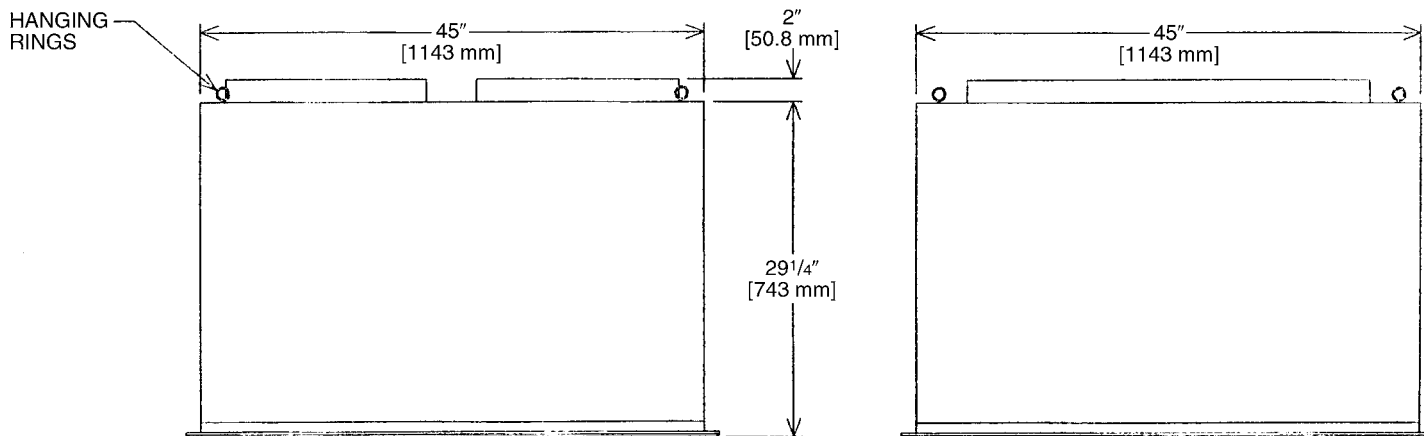
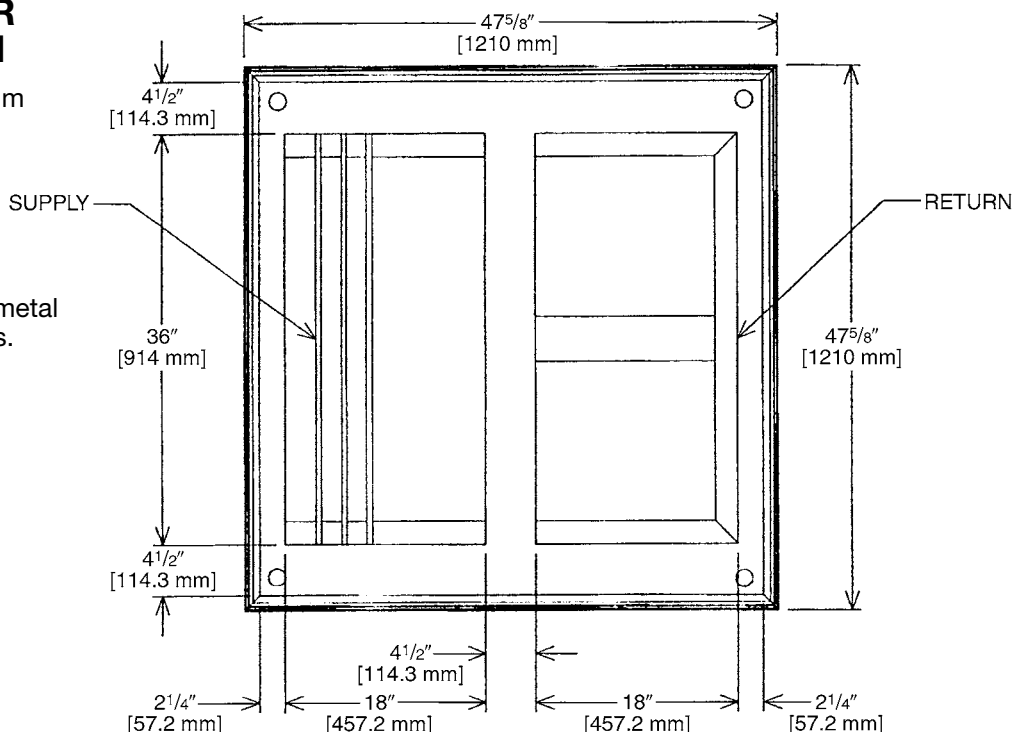

Illustration
ST-A1125-32
RXMC-CJ07

[] Designates Metric Conversions

CONCENTRIC DIFFUSER 15 TON [52.8 kW] FLUSH

- All aluminum diffuser with aluminum return air eggcrate.
- Built-in anti-sweat gasket.
- Molded fiberglass supports.
- Built-in hanging supports.
- Diffuser box constructed of sheetmetal insulated with 1" [25.4 mm] 1.5 lbs. [.7 kg] duct liner.



CONCENTRIC DIFFUSER SPECIFICATIONS

PART NUMBER	CFM [L/s]	STATIC PRESSURE	THROW FEET	NECK VELOCITY	JET VELOCITY
RXRN-AD80	5600 [2643]	0.36	28-37	1000	2082
	5800 [2737]	0.39	29-38	1036	2156
	6000 [2832]	0.42	40-50	1071	2230
	6200 [2926]	0.46	42-51	1107	2308
	6400 [3020]	0.50	43-52	1143	2379
	6600 [3115]	0.54	45-56	1179	2454

[] Designates Metric Conversions

CONCENTRIC DIFFUSER 15 TON [52.8 kW] STEP DOWN

- All aluminum diffuser with aluminum return air eggcrate.
- Built-in anti-sweat gasket.
- Molded fiberglass supports.
- Built-in hanging supports.
- Diffuser box constructed of sheetmetal insulated with 1" [25.4 mm] 1.5 lbs. [.7 kg] duct liner.
- Double deflection diffuser with the blades secured by spring steel.

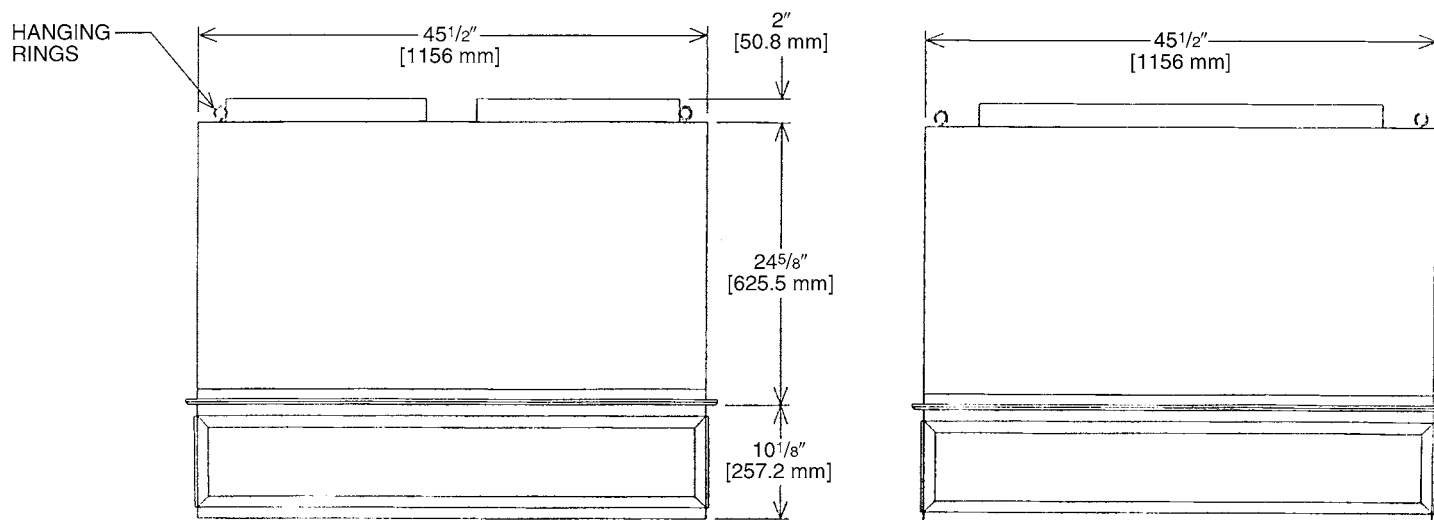
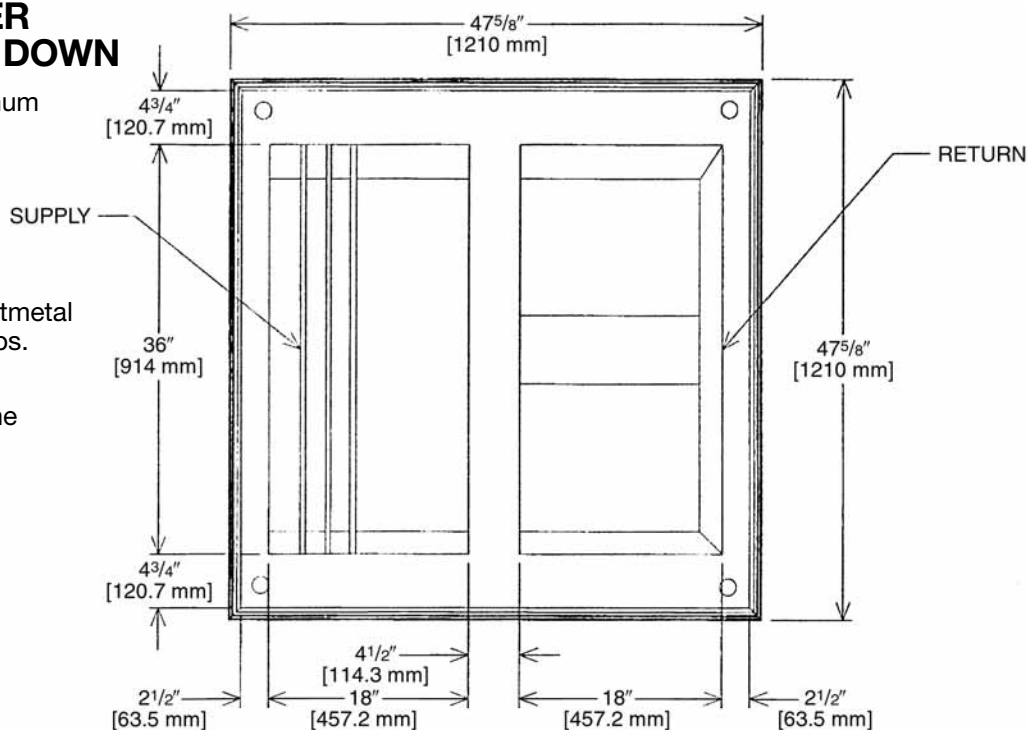

CONCENTRIC DIFFUSER SPECIFICATIONS

PART NUMBER	CFM [L/s]	STATIC PRESSURE	THROW FEET	NECK VELOCITY	JET VELOCITY
RXRN-AD81	5600 [2643]	0.36	39-49	920	920
	5800 [2737]	0.39	42-51	954	954
	6000 [2832]	0.42	44-54	1022	1022
	6200 [2926]	0.46	45-55	1056	1056
	6400 [3020]	0.50	46-55	1090	1090
	6600 [3115]	0.54	47-56	1124	1124

[] Designates Metric Conversions

FLUSH VALVE KIT

RXMV-AG

Contains two valves with union and 1-1/2" FPT connections for the H₂AC Rooftop Unit water lines

- Field Installed accessory serves as the H₂AC Rooftop Unit water shut off valves during unit servicing.
- Aids in the periodic flushing required for the refrigerant-to-water heat exchanger contained in the H₂AC Rooftop Unit to remove lime and scale buildup and to prevent degradation of water heating performance.
- Features 3/4" threaded hose connections for draining.



EMERGENCY ELECTRICALLY OPERATED WATER SHUTOFF VALVE

RXMV-AH

Shuts off water supply to the H₂AC Rooftop Unit if a leak is detected by the onboard sensor

- Field Installed accessory provided with 1-1/2" FPT connections.
- Standard Port, Bronze Ball Valve for low water pressure drop.
- 115 VAC motor connects to alarm dry contacts on eSync unit and separate power supply.
- Standard position indicator.
- Manual override standard.
- Mountable in any position.



WATER STORAGE TANK MANIFOLD KIT

RXMZ-A120A

Compact tank-hugging design provides components to connect the H₂AC rooftop unit to the water storage tank and the rest of the potable water heating system

- Field Installed accessory with 1-1/2" sweat connections to the H₂AC unit and 2" sweat connections to the hot water system.
- Reduces plumbing errors that prevent proper operation of the H₂AC unit. Components meet California law AB 1953 low-lead requirements.
- Standard Port, Bronze Ball Shutoff Valves for low water pressure drop.
- Bronze Check Valves prevent loss of H₂AC water pump prime during temporary water pressure loss and prevent water backflow when Emergency Water Shutoff valve is energized.
- Includes Di-electric Nipples and Di-electric Unions to water storage tank for building code compliance.
- Includes 3/4" hose bibs to bleed air out of the system after initial installation and to drain system for servicing.
- Includes bronze plugs for unused storage tank connections.

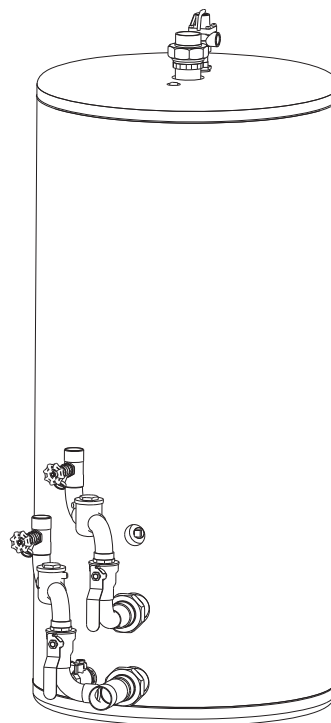

Illustration
ADS-104600-01

GUIDE SPECIFICATIONS – RLHL-D180

You may copy this document directly into your building specification. This specification is written to comply with the 2004 version of the “master format” as published by the Construction Specification Institute. www.csinet.org.

ELECTRIC HEAT PACKAGED ROOFTOP

HVAC Guide Specifications

Size Range: 15 Nominal Tons

<u>Section</u>	<u>Description</u>
----------------	--------------------

22 35 36	Domestic Water Brazed-Plate Heat Exchangers
-----------------	--

22 35 36.A	Domestic Water Brazed-Plate Heat Exchangers
-------------------	--

1. Unit shall contain a Double Wall, Vented, Brazed-Plate heat exchanger to provide preheating of domestic potable water by using refrigerant waste heat recovery from the packaged air conditioner.
2. Heat exchanger shall be mounted in the indoor air section of the packaged air conditioner.
3. Unit shall be provided with a stainless steel recirculation pump suitable for potable water.
4. Unit shall include controls to switch from air conditioning to water heating mode whenever heat recovery is possible.

23 06 80	Schedules for Decentralized HVAC Equipment
-----------------	---

23 06 80.13 Decentralized Unitary HVAC Equipment Schedule

23 06 80.13.A. Rooftop unit schedule

1. Schedule is per the project specification requirements.

23 07 16	HVAC Equipment Insulation
-----------------	----------------------------------

23 07 16.13 Decentralized, Rooftop Units:

1. Interior cabinet surfaces shall be insulated with a minimum 3/4-in. thick, minimum 1-1/2 lb density, flexible fiberglass insulation bonded with foil face on the air side.
2. Insulation and adhesive shall meet NFPA 90A requirements for flame spread and smoke generation.
3. Insulation shall also be mechanically fastened with welded pin and retainer washer.

23 09 13	Instrumentation and Control Devices for HVAC
-----------------	---

23 09 13.23 Sensors and Transmitters

23 09 13.23.A. Thermostats

1. Thermostat must
 - a. have capability to energize 2 different stages of cooling, and 2 different stages of heating.
 - b. must include capability for occupancy scheduling.

23 09 23	Direct-digital Control system for HVAC
-----------------	---

23 09 23.13 Decentralized, Rooftop Units:

23 09 23.13.A. RTU-C controller

1. Shall be ASHRAE 62-2001 compliant.
2. Shall accept 18-32VAC input power.
3. Shall have an operating temperature range from -40°F (-40°C) to 158°F (70°C), 10% - 95% RH (non-condensing).
4. Controller shall accept the following inputs: space temperature, setpoint adjustment, outdoor air temperature, indoor air quality, outdoor air enthalpy, fire shutdown, return air enthalpy, fan status, remote time clock/door switch.
5. Shall accept a CO₂ sensor in the conditioned space, and be Demand Control Ventilation (DCV) ready.
6. Shall provide the following outputs: Economizer, fan, cooling stage 1, cooling stage 2, heat stage 1, heat stage 2, exhaust, occupied.
7. Unit shall provide surge protection for the controller through a circuit breaker.
8. Shall have a field installed communication card allowing the unit to be Internet capable, and communicate at a Baud rate of 19.2K or faster
9. Shall have an LED display independently showing the status of activity on the communication bus, and processor operation.
10. Shall have either a field installed BACnet® plug-in communication card which includes an EIA-485 protocol communication port, or a field installed LonWorks™ plug-in communications card.
11. Software upgrades will be accomplished by local download. Software upgrades through chip replacements are not allowed.
12. Shall be shock resistant in all planes to 5G peak, 11ms during operation, and 100G peak, 11ms during storage.
13. Shall be vibration resistant in all planes to 1.5G @ 20-300 Hz.
14. Shall support a bus length of 4000 ft max, 60 devices per 1000 ft section, and 1 RS-485 repeater per 1000 ft sections.

23 09 23.13.B. Open protocol, direct digital controller:

1. Shall be ASHRAE 62-2001 compliant.
2. Shall accept 18-30VAC, 50-60Hz, and consume 15VA or less power.
3. Shall have an operating temperature range from -40°F (-40°C) to 130°F (54°C), 10% - 90% RH (non-condensing).
4. Shall have either a field installed BACnet® plug-in communication card which includes an EIA-485 protocol communication port, or a field installed LonWorks™ plug-in communications card.
5. The BACnet® plug in communication card shall include built-in protocol for BACNET (MS/TP and PTP modes)
6. The LonWorks™ plug in communication card shall include the Echelon processor required for all Lon applications.
7. Shall allow access of up to 62 network variables (SNVT). Shall be compatible with all open controllers

8. Baud rate Controller shall be selectable through the EIA-485 protocol communication port.
9. Shall have an LED display independently showing the status of serial communication, running, errors, power, all digital outputs, and all analog inputs.
10. Shall accept the following inputs: space temperature, setpoint adjustment, outdoor air temperature, indoor air quality, outdoor air enthalpy, compressor lock-out, fire shutdown, enthalpy switch, and fan status/filter status/ humidity/ remote occupancy.
11. Shall provide the following outputs: economizer, fan, cooling stage 1, cooling stage 2, heat stage 1, heat stage 2, exhaust.
12. Software upgrades will be accomplished by either local or remote download. No software upgrades through chip replacements are allowed.

23 09 33 Electric and Electronic Control System for HVAC

23 09 33.13 Decentralized, Rooftop Units:

23 09 33.13.A. General:

1. Shall be complete with self-contained low-voltage control circuit protected by a resettable circuit breaker on the 24-v transformer side. Transformer shall have 100VA capabilities.
2. Shall utilize color-coded wiring.
3. Shall include a central control terminal board to conveniently and safely provide connection points for vital control functions such as: smoke detectors, phase monitor, economizer, thermostat, DDC control options, loss of charge, freeze sensor, high pressure switches.
4. Unit shall include a minimum of one 10-pin screw terminal connection board for connection of control wiring.

23 09 33.23.B. Safeties:

1. Compressor over-temperature, over current.
2. Loss of charge switch.
 - a. Units with 2 compressors shall have different colored wires for the circuit 1 and circuit 2 low and high pressure switches.
 - b. Loss of charge switch shall use different color wire than the high pressure switch. The purpose is to assist the installer and service technician to correctly wire and or troubleshoot the rooftop unit.
 - c. Loss of charge switch shall have a different sized connector than the high pressure switch. They shall physically prevent the cross-wiring of the safety switches between the high and low pressure side of the system.
3. High-pressure switch.
 - a. Units with 2 compressors shall have different colored wires for the circuit 1 and circuit 2 low and high pressure switches.
 - b. High pressure switch shall use different color wire than the low pressure switch. The purpose is to assist the installer and service person to correctly wire and or troubleshoot the rooftop unit.
 - c. High pressure switch shall have a different sized connector than the loss of charge switch. They shall physically prevent the cross-wiring of the safety switches between the high and low pressure side of the system.
4. Freeze protection sensor, evaporator coil.
5. Automatic reset, motor thermal overload protector.

23 09 93 Sequence of Operations for HVAC Controls

23 09 93.13 Decentralized, Rooftop Units:

23 09 93.13 INSERT SEQUENCE OF OPERATION

23 40 13 Panel Air Filters

23 40 13.13 Decentralized, Rooftop Units:

23 40 13.13.A. Standard filter section shall

1. Shall consist of factory-installed, low velocity, throwaway 2-in. thick fiberglass filters of commercially available sizes.
2. Unit shall use only one filter size. Multiple sizes are not acceptable.
3. Filter face velocity shall not exceed 365 fpm at nominal airflows.
4. Filters shall be accessible through an access panel with "no-tool" removal as described in the unit cabinet section of the specification (23 81 19.13.H).

23 81 19 Self-Contained Air Conditioners

23 81 19.13 Small-Capacity Self-Contained Air Conditioners

23 81 19.13.A. General

1. Outdoor, rooftop mounted, electrically controlled, heating and cooling unit utilizing a(n) hermetic scroll compressor(s) for cooling duty and heat pump for heating duty.
2. Factory assembled, single-piece heating and cooling rooftop unit. Contained within the unit enclosure shall be all factory wiring, piping, controls, and special features required prior to field start-up.
3. Unit shall use environmentally sound R-410A refrigerant.
4. Unit shall be installed in accordance with the manufacturer's instructions.
5. Unit must be selected and installed in compliance with local, state, and federal codes.

23 81 19.13.B. Quality Assurance

1. Unit meets ASHRAE 90.1-2004 minimum efficiency requirements.
2. 3 phase units are Energy Star qualified.
3. Unit shall be rated in accordance with AHRI Standards 340/360.
4. Unit shall be designed to conform to ASHRAE 15, 2001.

5. Unit shall be UL-tested and certified in accordance with ANSI Z21.47 Standards and UL-listed and certified under Canadian standards as a total package for safety requirements.
 6. Insulation and adhesive shall meet NFPA 90A requirements for flame spread and smoke generation.
 7. Unit casing shall be capable of withstanding 1000-hour salt spray exposure per ASTM B117 (scribed specimen).
 8. Unit casing shall be capable of withstanding Federal Test Method Standard No. 141 (Method 6061) 5000-hour salt spray.
 9. Unit shall be designed in accordance with ISO 9001:2000, and shall be manufactured in a facility registered by ISO 9001:2000.
 10. Roof curb shall be designed to conform to NRCA Standards.
 11. Unit shall be subjected to a completely automated run test on the assembly line. The data for each unit will be stored at the factory, and must be available upon request.
 12. Unit shall be designed in accordance with UL Standard 1995, including tested to withstand rain.
 13. Unit shall be constructed to prevent intrusion of snow and tested to prevent snow intrusion into the control box up to 40 mph.
- 23 81 19.13.C. Delivery, Storage, and Handling
1. Unit shall be stored and handled per manufacturer's recommendations.
 2. Lifted by crane requires either shipping top panel or spreader bars.
 3. Unit shall only be stored or positioned in the upright position.
- 23 81 19.13.E. Project Conditions
1. As specified in the contract.
- 23 81 19.13.F. Operating Characteristics
1. Unit shall be capable of starting and running at 115°F (46°C) ambient outdoor temperature, meeting maximum load criteria of AHRI Standard 210/240 or 360 at $\pm 10\%$ voltage.
 2. Compressor with standard controls shall be capable of operation down to 50°F (10°C), ambient outdoor temperatures. Low ambient accessory kit is necessary if mechanically cooling at ambient temperatures to 0°F (-17.7°C).
 3. Unit shall be factory configured for vertical supply & return configurations.
- 23 81 19.13.G. Electrical Requirements
1. Main power supply voltage, phase, and frequency must match those required by the manufacturer.
- 23 81 19.13.H. Unit Cabinet
1. Unit cabinet shall be constructed of galvanized steel, and shall be bonderized and coated with a baked enamel finish on all externally exposed surfaces.
 2. Unit cabinet exterior paint shall be: film thickness, (dry) 0.003 inches minimum, gloss (per ASTM D523, 60°F): 60, Hardness: H-2H Pencil hardness.
 3. Evaporator fan compartment interior cabinet insulation shall conform to AHRI Standards 210/240 or 340/360 minimum exterior sweat criteria. Interior surfaces shall be insulated with a minimum 3/4-in. thick, 1 lb density, flexible fiberglass insulation, aluminum foil-faced on the air side.
 4. Base of unit shall have locations for thru-the-base electrical connections (factory installed or field installed), standard.
5. Base Rail
- a. Unit shall have base rails on a minimum of 4 sides.
 - b. Holes shall be provided in the base rails for rigging shackles to facilitate maneuvering and overhead rigging.
 - c. Holes shall be provided in the base rail for moving the rooftop by fork truck.
 - d. Base rail shall be a minimum of 14 gauge thickness.
6. Condensate pan and connections:
- a. Shall be a sloped condensate drain pan made of a non-corrosive material and be removable for cleaning.
 - b. Shall comply with ASHRAE Standard 62.
 - c. Shall use a 1" -11 1/2 NPT drain connection, through the side of the drain pan. Connection shall be made per manufacturer's recommendations.
 - d. Shall be able to be easily removed.
7. Top panel:
- a. Shall be a single piece top panel over indoor section.
8. Electrical Connections:
- a. All unit power wiring shall enter unit cabinet a single, factory-prepared, continuous raised flange opening in the basepan.
 - b. Thru-the-base capability
 - i. Standard unit shall have a thru-the-base electrical location(s) using a raised, continuous raised flange opening in the basepan.
 - ii. No basepan penetration, other than those authorized by the manufacturer, is permitted.
9. Component access panels (standard)
- a. Cabinet panels shall be easily opened for servicing.
 - b. Panels covering control box, indoor fan, indoor fan motor, gas components (where applicable), and filters shall have hinges with 1/4 turn fasteners.
 - c. 1/4 fasteners shall be permanently attached.

23 81 19.13.J. Coils

1. Standard Aluminum/Copper Coils:

- a. Standard evaporator coil shall be aluminum lanced plate fins mechanically bonded to seamless internally grooved copper tubes with all joints brazed. All aluminum MicroChannel condensing coil.
- b. Evaporator and condenser coils shall be leak tested to 150 psig, pressure tested to 400 psig, and qualified to UL 1995 burst test at 2,200 psi.

23 81 19.13.K. Refrigerant Components

1. Refrigerant circuit shall include the following control, safety, and maintenance features:

- a. TXV metering system shall prevent mal-distribution of two-phase refrigerant.
- b. Refrigerant filter drier.
- c. Service gauge connections on suction and discharge lines.
- d. External pressure gauge ports access shall be located in front exterior of cabinet.

2. Compressors

- a. Unit shall use one fully hermetic, scroll compressor for each independent refrigeration circuit.
- b. Compressor motors shall be cooled by refrigerant gas passing through motor windings.
- d. Compressors shall be internally protected from high discharge temperature conditions.
- e. Compressors shall be protected from an over-temperature and over-ampereage conditions by an internal, motor overload device.
- f. Compressor shall be factory mounted on rubber grommets.
- g. Compressor motors shall have internal line break thermal and current overload protection.
- h. Crankcase heaters shall not be required for normal operating range.

23 81 19.13.L. Filter Section

1. Filters access is specified in the unit cabinet section of this specification.
2. Filters shall be held in place by a sliding filter tray, facilitating easy removal and installation.
3. Shall consist of factory-installed, low velocity, throw-away 2-in. thick fiberglass filters.
4. Filter face velocity shall not exceed 320 fpm at nominal airflows.
5. Filters shall be standard, commercially available sizes.
6. Only one size filter per unit is allowed.

23 81 19.13.M. Evaporator Fan and Motor

1. Evaporator fan motor:

- a. Shall have permanently lubricated bearings.
- b. Shall have inherent automatic-reset thermal overload protection.
- c. Shall have a maximum continuous bhp rating for continuous duty operation; no safety factors above that rating shall be required.

2. Belt-driven Evaporator Fan:

- a. Belt drive shall include an adjustable-pitch motor pulley.
- b. Shall use sealed, permanently lubricated ball-bearing type.
- c. Blower fan shall be double-inlet type with forward-curved blades.
- d. Shall be constructed from steel with a corrosion resistant finish and dynamically balanced.

23 81 19.13.N. Condenser Fans and Motors

1. Condenser fan motors:

- a. Shall be a totally enclosed motor.
- b. Shall use permanently lubricated bearings.
- c. Shall have inherent thermal overload protection with an automatic reset feature.
- d. Shall use a shaft-down design. Shaft-up designs including those with "rain-slinger devices" shall not be allowed.

2. Condenser Fans:

- a. Shall be a direct-driven propeller type fan.
- b. Shall have aluminum blades riveted to corrosion-resistant steel spiders and shall be dynamically balanced.

23 81 19.13.O. Special Features

1. Integrated Economizers:

- a. Integrated, gear-driven parallel modulating blade design type capable of simultaneous economizer and compressor operation.
- b. Independent modules for vertical or horizontal return configurations shall be available. Vertical return modules shall be available as a factory installed option.
- c. Damper blades shall be galvanized steel with metal gears. Plastic or composite blades on intake or return shall not be acceptable.
- d. Shall include all hardware and controls to provide free cooling with outdoor air when temperature and/or humidity are below setpoints.
- e. Shall be equipped with gear driven dampers for both the outdoor ventilation air and the return air for positive air stream control.

- f. Shall be capable of introducing up to 100% outdoor air.
 - g. Shall be equipped with a barometric relief damper capable of relieving up to 100% return air.
 - h. Shall be designed to close damper(s) during loss-of-power situations with spring return built into motor.
 - i. An outdoor single enthalpy sensor shall be provided as standard. Outdoor air sensor setpoint shall be adjustable and shall range from the enthalpy equivalent of 63°F @ 50% rh to 73°F @ 50% rh. Additional sensor options shall be available as accessories.
 - j. The economizer controller shall also provide control of an accessory power exhaust unit function. Factory set at 70%, with a range of 0% to 100%.
 - k. The economizer shall maintain minimum airflow into the building during occupied period and provide design ventilation rate for full occupancy. A remote potentiometer may be used to override the damper setpoint.
 - l. Dampers shall be completely closed when the unit is in the unoccupied mode.
 - m. Economizer controller shall accept a 2-10Vdc CO₂ sensor input for IAQ/DCV control. In this mode, dampers shall modulate the outdoor-air damper to provide ventilation based on the sensor input.
 - n. Compressor lockout sensor on the unit controller is factory set at 35°F and is adjustable from 0°F (-18°C) to 50°F (10°C) and resets the cooling lockout at 5°F (+2.7°C) above the set point.
 - o. Actuator shall be direct coupled to economizer gear. No linkage arms or control rods shall be acceptable.
 - p. Economizer controller shall provide indications when in free cooling mode, in the DCV mode, or the exhaust fan contact is closed.
 - q. Economizer wire harness will have provision for smoke detector.
2. Two-Position Motorized Damper
- a. Damper shall be a Two-Position Motorized Damper. Damper travel shall be from the full closed position to the field adjustable %-open setpoint.
 - b. Damper shall include adjustable damper travel from 25% to 100% (full open).
 - c. Damper shall include single or dual blade, gear driven dampers and actuator motor.
 - d. Actuator shall be direct coupled to damper gear. No linkage arms or control rods shall be acceptable.
 - e. Damper will admit up to 100% outdoor air for applicable rooftop units.
 - f. Damper shall close upon indoor (evaporator) fan shutoff and/or loss of power.
 - g. The damper actuator shall plug into the rooftop unit's wiring harness plug. No hard wiring shall be required.
 - h. Outside air hood shall include aluminum water entrainment filter
3. Manual damper
- a. Manual damper package shall consist of damper, air inlet screen, and rain hood which can be preset to admit up to 50% outdoor air for year round ventilation.
4. Head Pressure Control Package
- a. Controller shall control coil head pressure by condenser-fan cycling.
5. Condenser Coil Hail Guard Assembly
- a. Shall protect against damage from hail.
 - b. Shall be louvered design.
6. Convenience Outlet:
- a. Non-Powered convenience outlet.
 - b. Outlet shall be powered from a separate 115-120 Vac power source.
 - c. A transformer shall not be included.
 - d. Outlet shall be factory-installed and internally mounted with easily accessible 115 Vac female receptacle.
 - e. Outlet shall include 15 amp GFI receptacle.
 - f. Outlet shall be accessible from outside the unit.
7. Fan/Filter Status Switch:
- a. Switch shall provide status of indoor evaporator fan (ON/OFF) or filter (CLEAN/DIRTY).
 - b. Status shall be displayed either over communication bus (when used with direct digital controls) or through the controller LCD display inside the unit control box.
8. Propeller Power Exhaust:
- a. Power exhaust shall be used in conjunction with an integrated economizer.
 - b. Independent modules for vertical or horizontal return configurations shall be available.
 - c. Horizontal power exhaust shall be mounted in return ductwork.
 - d. Power exhaust shall be controlled by economizer controller operation. Exhaust fans shall be energized when dampers open past the 0-100% adjustable setpoint on the economizer control.
9. Roof Curbs (Vertical):
- a. Formed galvanized steel with wood nailer strip and shall be capable of supporting entire unit weight.
 - b. Permits installation and securing of ductwork to curb prior to mounting unit on the curb.
10. High-Static Indoor Fan Motor(s) and Drive(s):
- a. High-static motor(s) and drive(s) shall be factory-installed to provide additional performance range.

11. Outdoor Air Enthalpy Sensor:
 - a. The outdoor air enthalpy sensor shall be used to provide single enthalpy control. When used in conjunction with a return air enthalpy sensor, the unit will provide differential enthalpy control. The sensor allows the unit to determine if outside air is suitable for free cooling.
12. Return Air Enthalpy Sensor:
 - a. The return air enthalpy sensor shall be used in conjunction with an outdoor air enthalpy sensor to provide differential enthalpy control.
13. Indoor Air Quality (CO₂) Sensor:
 - a. Shall be able to provide demand ventilation indoor air quality (IAQ) control.
 - b. The IAQ sensor shall be available in wall mount with LED display. The setpoint shall have adjustment capability.
14. Smoke detectors:
 - a. Shall be a Four-Wire Controller and Detector.
 - b. Shall be environmental compensated with differential sensing for reliable, stable, and drift-free sensitivity.
 - c. Shall use magnet-activated test/reset sensor switches.
 - d. Shall have a recessed momentary switch for testing and resetting the detector.
 - e. Controller shall include:
 - i. One set of normally open alarm initiation contacts for connection to an initiating device circuit on a fire alarm control panel.
 - ii. Two Form-C auxiliary alarm relays for interface with rooftop unit or other equipment.
 - iii. One Form-C supervision (trouble) relay to control the operation of the Trouble LED on a remote test/reset station.
 - iv. Capable of direct connection to two individual detector modules.
 - v. Can be wired to up to 14 other duct smoke detectors for multiple fan shutdown applications.
15. Barometric relief
 - a. Shall include damper, seals, hardware, and hoods to relieve excess building pressure.
 - b. Damper shall gravity-close upon shutdown.
16. Electric Heat:
 - a. Heating Section
 - i. Heater element open coil resistance wire, nickel-chrome alloy, strung through ceramic insulators mounted on metal frame. Coil ends are staked and welded to terminal screw slots.
 - ii. Heater assemblies are provided with integral fusing for protection of internal heater circuits not exceeding 48 amps each. Auto reset thermo limit controls, magnetic heater contactors (24 v coil) and terminal block all mounted in electric heater control box (minimum 18 ga galvanized steel) attached to end of heater assembly.

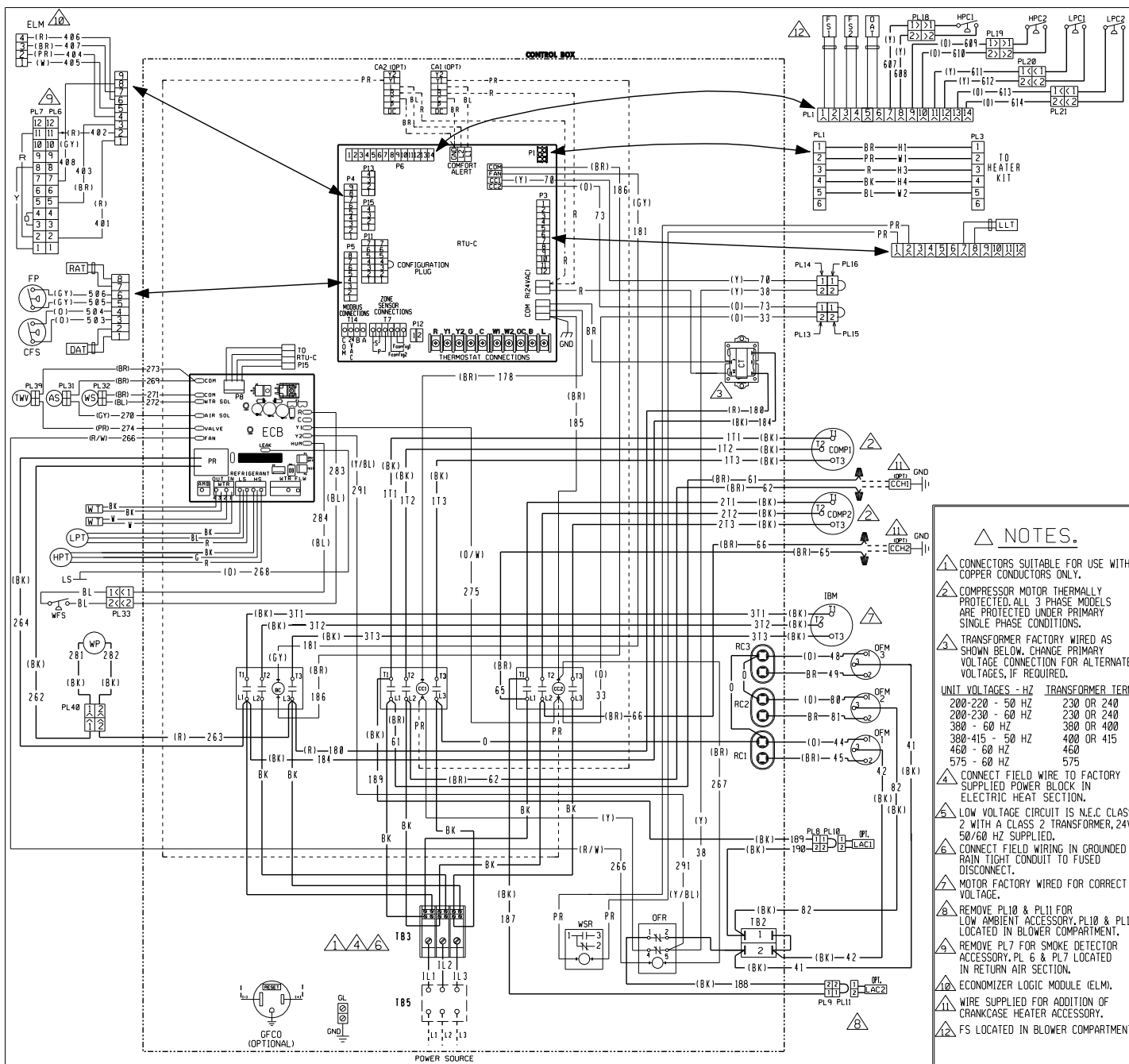

- NOTES.**
- 1. CONNECTORS SUITABLE FOR USE WITH COPPER CONDUCTORS ONLY.
 - 2. COMPRESSOR MOTOR THERMALLY PROTECTED. ALL 3 PHASE MODELS ARE PROTECTED UNDER PRIMARY SINGLE PHASE CONDITIONS.
 - 3. TRANSFORMER FACTORY WIRED AS SHOWN BELOW. CHANGE PRIMARY VOLTAGE CONNECTION FOR ALTERNATE VOLTAGES, IF REQUIRED.
- | UNIT VOLTAGES - HZ | TRANSFORMER TERM. |
|--------------------|-------------------|
| 200-220 - 50 HZ | 230 OR 240 |
| 200-230 - 60 HZ | 230 OR 240 |
| 380 - 60 HZ | 380 OR 400 |
| 380-415 - 50 HZ | 400 OR 415 |
| 460 - 60 HZ | 460 |
| 575 - 60 HZ | 575 |
- 4. CONNECT FIELD WIRE TO FACTORY SUPPLIED POWER BLOCK IN ELECTRIC HEAT SECTION.
 - 5. LOW VOLTAGE CIRCUIT IS N.E.C. CLASS 2 WITH A CLASS 2 TRANSFORMER, 24V, 50/60 HZ SUPPLIED.
 - 6. CONNECT FIELD WIRING IN GROUNDED RAIN TIGHT CONDUIT TO FUSED DISCONNECT.
 - 7. MOTOR FACTORY WIRED FOR CORRECT VOLTAGE.
 - 8. REMOVE PL10 & PL11 FOR LOW AMBIENT ACCESSORY. PL10 & PL11 LOCATED IN BLOWER COMPARTMENT.
 - 9. REMOVE PL7 FOR SMOKE DETECTOR ACCESSORY. PL 6 & PL7 LOCATED IN RETURN AIR SECTION.
 - 10. ECONOMIZER LOGIC MODULE (ELM).
 - 11. WIRE SUPPLIED FOR ADDITION OF CRANKCASE HEATER ACCESSORY.
 - 12. FS LOCATED IN BLOWER COMPARTMENT.

COMPONENT CODE

AS AIR SOLENOID	HPT HIGH PRESSURE TRANSDUCER	TWV THREE-WAY VALVE
BC BLOWER CONTACTOR	IBM INDOOR BLOWER MOTOR	WFS WATER FLOW SWITCH
CA COMFORT ALERT MODULE	IFC INTEGRATED FURNACE CONTROL	WP WATER PUMP
CC COMPRESSOR CONTACTOR	LAC LOW AMBIENT COOLING CONTROL	WS WATER SOLENOID
CCH CRANKCASE HEATER	LLT LIQUID LINE TEMPERATURE	WSR WATER SHUTOFF RELAY
CFS CLOGGED FILTER SWITCH	LPC LOW PRESSURE CONTROL	WT WATER TEMPERATURE SENSER
COMP COMPRESSOR	LPT LOW PRESSURE TRANSDUCER	WIRE NUT
CT CONTROL TRANSFORMER	LS LEAK SENSOR	
DAT DISCHARGE AIR SENSOR	OAT OUTSIDE AIR SENSOR	
DISC DISCONNECT SWITCH	OFM OUTDOOR FAN MOTOR	
ECB ESIGN CONTROL BOARD	OFR OUTDOOR FAN RELAY	
FP FAN PROVING	PL PLUG	
FS FREEZE SENSOR	PR PUMP RELAY	
GFCD GROUND FAULT	RAT RETURN AIR SENSOR	
GL GROUND OUTLET	RC RUN CAPACITOR	
GND GROUND	RTU-C ROOFTOP UNIT CONTROL	
HPC HIGH PRESSURE CONTROL	TB TERMINAL BLOCK	

WIRING INFORMATION

LINE VOLTAGE
 -FACTORY STANDARD _____
 -FACTORY OPTION - - - - -
 -FIELD INSTALLED - - - - -

LOW VOLTAGE
 -FACTORY STANDARD _____
 -FACTORY OPTION - - - - -
 -FIELD INSTALLED - - - - -

REPLACEMENT WIRE
 -MUST BE THE SAME SIZE AND TYPE OF INSULATION AS ORIGINAL (105° C MIN.)

WARNING
 -CABINET MUST BE PERMANENTLY GROUNDED AND CONFORM TO I.E.C., N.E.C., C.E.C., AND LOCAL CODES AS APPLICABLE.

WIRE COLOR CODE

BK BLACK	O ORANGE
BR BROWN	PR PURPLE
BL BLUE	R RED
G GREEN	W WHITE
GY GRAY	Y YELLOW

WIRING DIAGRAM
RLHL-D180
 208-230V 3 PH, 60 HZ.
 PACKAGED A/C W/RTU-C

DR. BY	APP. BY	DATE	DWG. NO.	REV
MGR		1-4-13	90-104652-03	00

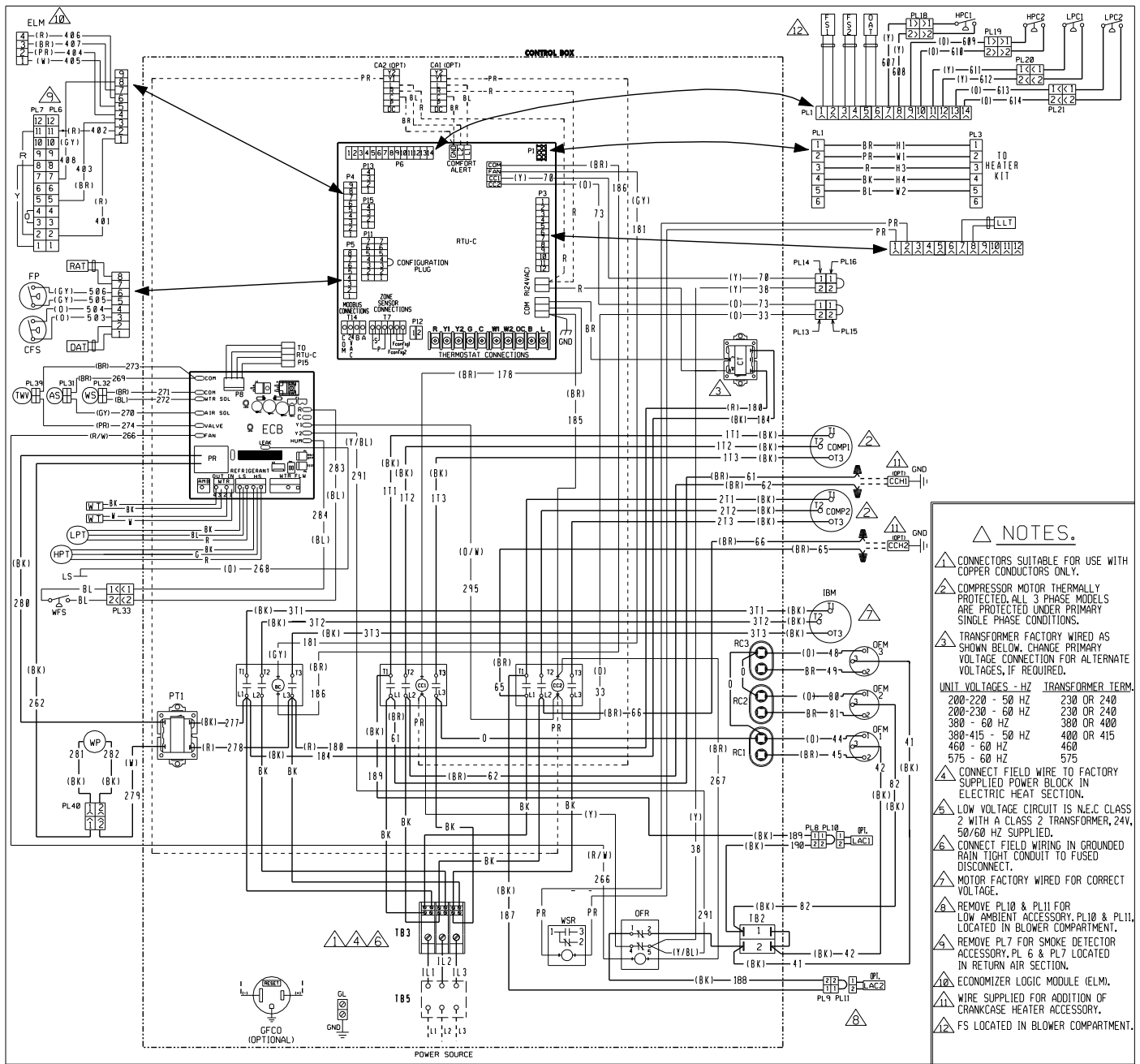

- NOTES.**
- △ CONNECTORS SUITABLE FOR USE WITH COPPER CONDUCTORS ONLY.
 - △ COMPRESSOR MOTOR THERMALLY PROTECTED, ALL 3 PHASE MODELS ARE PROTECTED UNDER PRIMARY SINGLE PHASE CONDITIONS.
 - △ TRANSFORMER FACTORY WIRING AS SHOWN BELOW. CHANGE PRIMARY VOLTAGE CONNECTION FOR ALTERNATE VOLTAGES, IF REQUIRED.
- | UNIT VOLTAGES - HZ | TRANSFORMER TERM. |
|--------------------|-------------------|
| 200-220 - 50 HZ | 230 OR 240 |
| 200-230 - 60 HZ | 230 OR 240 |
| 380 - 60 HZ | 380 OR 400 |
| 380-415 - 50 HZ | 400 OR 415 |
| 460 - 60 HZ | 460 |
| 575 - 60 HZ | 575 |
- △ CONNECT FIELD WIRE TO FACTORY SUPPLIED POWER BLOCK IN ELECTRIC HEAT SECTION.
 - △ LOW VOLTAGE CIRCUIT IS N.E.C. CLASS 2 WITH A CLASS 2 TRANSFORMER, 24V, 50/60 HZ SUPPLIED.
 - △ CONNECT FIELD WIRING IN GROUNDED RAIN TIGHT CONDUIT TO FUSED DISCONNECT.
 - △ MOTOR FACTORY WIRING FOR CORRECT VOLTAGE.
 - △ REMOVE PL10 & PL11 FOR LOW AMBIENT ACCESSORY. PL10 & PL11 LOCATED IN BLOWER COMPARTMENT.
 - △ REMOVE PL7 FOR SMOKE DETECTOR ACCESSORY. PL 6 & PL7 LOCATED IN RETURN AIR SECTION.
 - △ ECONOMIZER LOGIC MODULE (ELM).
 - △ WIRE SUPPLIED FOR ADDITION OF CRANKCASE HEATER ACCESSORY.
 - △ FS LOCATED IN BLOWER COMPARTMENT.

COMPONENT CODE

AS AIR SOLENOID	HPT HIGH PRESSURE TRANSDUCER	TB TERMINAL BLOCK
BC BLOWER CONTACTOR	IBM INDOOR BLOWER MOTOR	TWV THREE-WAY VALVE
CA COMFORT ALERT MODULE	LAC LOW AMBIENT COOLING CONTROL	WFS WATER FLOW
CC COMPRESSOR CONTACTOR	LLT LIQUID LINE TEMPERATURE	WP WATER PUMP
CCH CRANKCASE HEATER	LPC LOW PRESSURE CONTROL	WS WATER SOLENOID
CFS CLOGGED FILTER SWITCH	LPT LOW PRESSURE TRANSDUCER	WSR WATER SHUTOFF
COMP COMPRESSOR	LS LEAK SENSOR	WT WATER TEMPERATURE
CT CONTROL TRANSFORMER	OAT OUTSIDE AIR SENSOR	WTS WATER SENSER
DAT DISCHARGE AIR SENSOR	OFM OUTDOOR FAN MOTOR	WTR WATER RELAY
DISC DISCONNECT SWITCH	OFM OUTDOOR FAN MOTOR	WTR WATER RELAY
ESYNC ESTYNC CONTROL BOARD	OFR OUTDOOR FAN RELAY	WTR WATER RELAY
FP FAN PROVING	PL PLUG	WTR WATER RELAY
FS FREEZE SENSOR	PR PUMP RELAY	WTR WATER RELAY
GFCO GROUND FAULT	PT POWER TRANSFORMER	WTR WATER RELAY
CONV CONVENIENCE OUTLET	RAT RETURN AIR SENSOR	WTR WATER RELAY
GL GROUND LUG	RC RUN CAPACITOR	WTR WATER RELAY
GND GROUND	RTU-C ROOFTOP UNIT CONTROL	WTR WATER RELAY
HPC HIGH PRESSURE CONTROL		WTR WATER RELAY

WIRING INFORMATION

LINE VOLTAGE
 -FACTORY STANDARD _____
 -FACTORY OPTION _____
 -FIELD INSTALLED _____

LOW VOLTAGE
 -FACTORY STANDARD _____
 -FACTORY OPTION _____
 -FIELD INSTALLED _____

REPLACEMENT WIRE
 -MUST BE THE SAME SIZE AND TYPE OF INSULATION AS ORIGINAL (105° C MIN.)

WARNING
 -CABINET MUST BE PERMANENTLY GROUNDED AND CONFORM TO I.E.C., N.E.C. C.E.C., AND LOCAL CODES AS APPLICABLE.

WIRE COLOR CODE

BK BLACK	O ORANGE
BR BROWN	PR PURPLE
BL BLUE	R RED
G GREEN	W WHITE
GY GRAY	Y YELLOW

WIRING DIAGRAM
RLHL-D180
 460V 3 PH, 60 HZ.
 PACKAGED A/C W/RTU-C

DR. BY	APP. BY	DATE	DWG. NO.	REV
MGR		1-4-13	90-104652-04	00

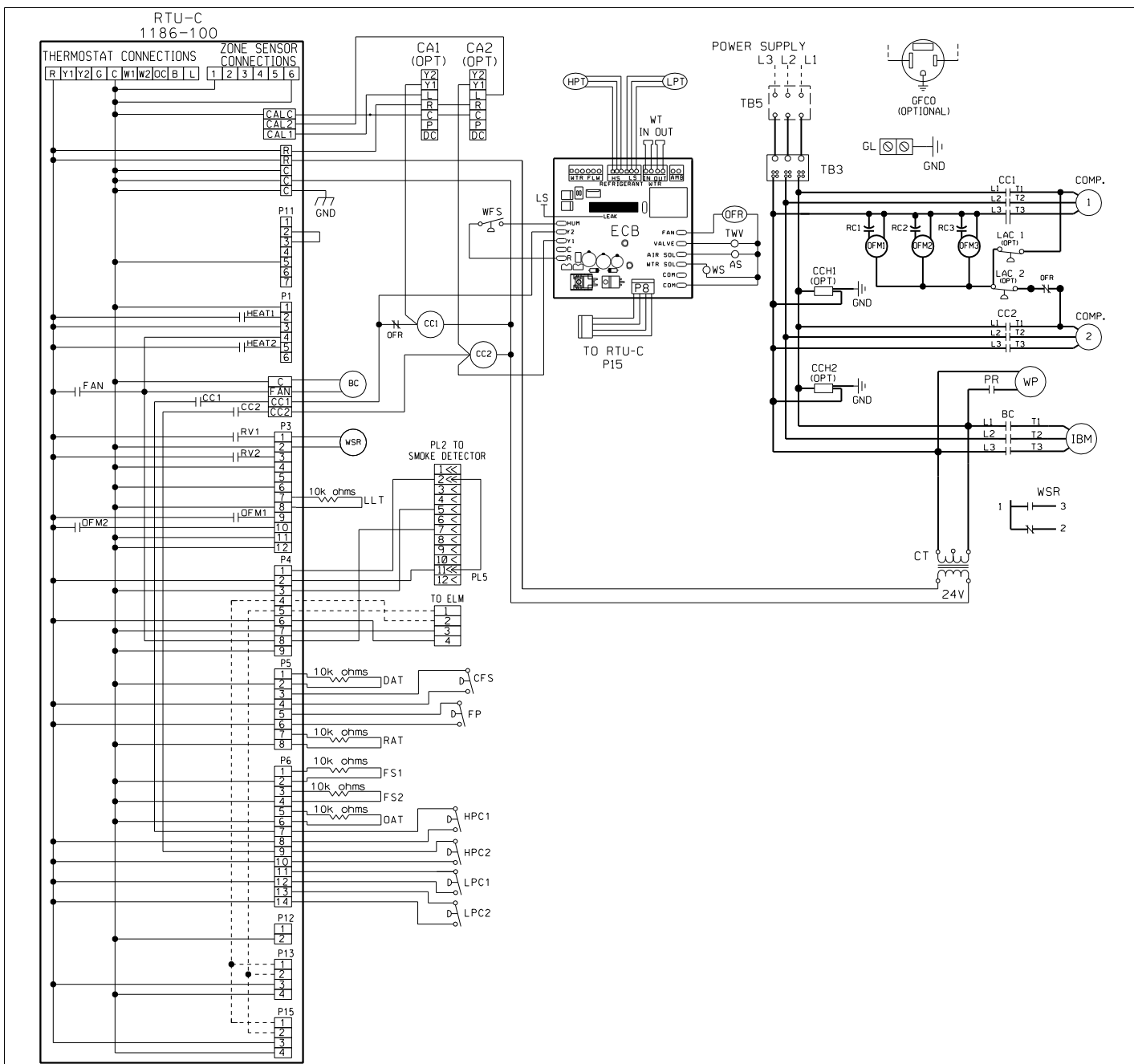

COMPONENT CODE

AS	AIR SOLENOID	HPT	HIGH PRESSURE TRANSDUCER	TW	THREE-WAY VALVE
BC	BLOWER CONTACTOR	IBM	INDOOR BLOWER MOTOR	WFS	WATER FLOW SWITCH
CA	COMFORT ALERT MODULE	IFC	INTEGRATED FURNACE CONTROL	WP	WATER PUMP
CC	COMPRESSOR CONTACTOR	LAC	LOW AMBIENT COOLING CONTROL	WS	WATER SOLENOID RELAY
CCH	CRANKCASE HEATER	LLT	LIQUID LINE TEMPERATURE	WSR	WATER SHUTOFF RELAY
CFM	CLOGGED FILTER SWITCH	LPC	LOW PRESSURE CONTROL	WT	WATER TEMPERATURE SENSOR
COMP	COMPRESSOR	LPT	LOW PRESSURE TRANSDUCER	W	WIRE NUT
CT	CONTROL TRANSFORMER	LS	LEAK SENSOR		
DISC	DISCONNECT SWITCH	OAT	OUTSIDE AIR SENSOR		
ECB	ESYNC CONTROL BOARD	OFM	OUTDOOR FAN MOTOR		
FP	FAN PROVING	OFR	OUTDOOR FAN RELAY		
FS	FREEZE SENSOR	PL	PLUG		
GFCO	GROUND FAULT CONVENIENCE OUTLET	PR	PUMP RELAY		
GL	GROUND LUG	RAT	RETURN AIR SENSOR		
GND	GROUND	RC	RUN CAPACITOR		
HPC	HIGH PRESSURE CONTROL	RTU-C	ROOFTOP UNIT CONTROL		
		TB	TERMINAL BLOCK		

WIRING INFORMATION

LINE VOLTAGE
 -FACTORY STANDARD _____
 -FACTORY OPTION _____
 -FIELD INSTALLED _____

LOW VOLTAGE
 -FACTORY STANDARD _____
 -FACTORY OPTION _____
 -FIELD INSTALLED _____

REPLACEMENT WIRE
 -MUST BE THE SAME SIZE AND TYPE OF INSULATION AS ORIGINAL (105° C MIN.)

WARNING
 -CABINET MUST BE PERMANENTLY GROUNDED AND CONFORM TO I.E.C., N.E.C., C.E.C., AND LOCAL CODES AS APPLICABLE.

WIRE COLOR CODE

BK	_BLACK	O	_ORANGE
BR	_BROWN	PR	_PURPLE
BL	_BLUE	R	_RED
G	_GREEN	W	_WHITE
GY	_GRAY	Y	_YELLOW

WIRING SCHEMATIC

RLHL-D180
 208-230V 3 PH, 60 HZ.
 PACKAGED A/C W/RTU-C

DR. BY MGR	APP. BY	DATE 1-7-13	DWG. NO. 90-104655-03	REV 00
---------------	---------	----------------	--------------------------	-----------

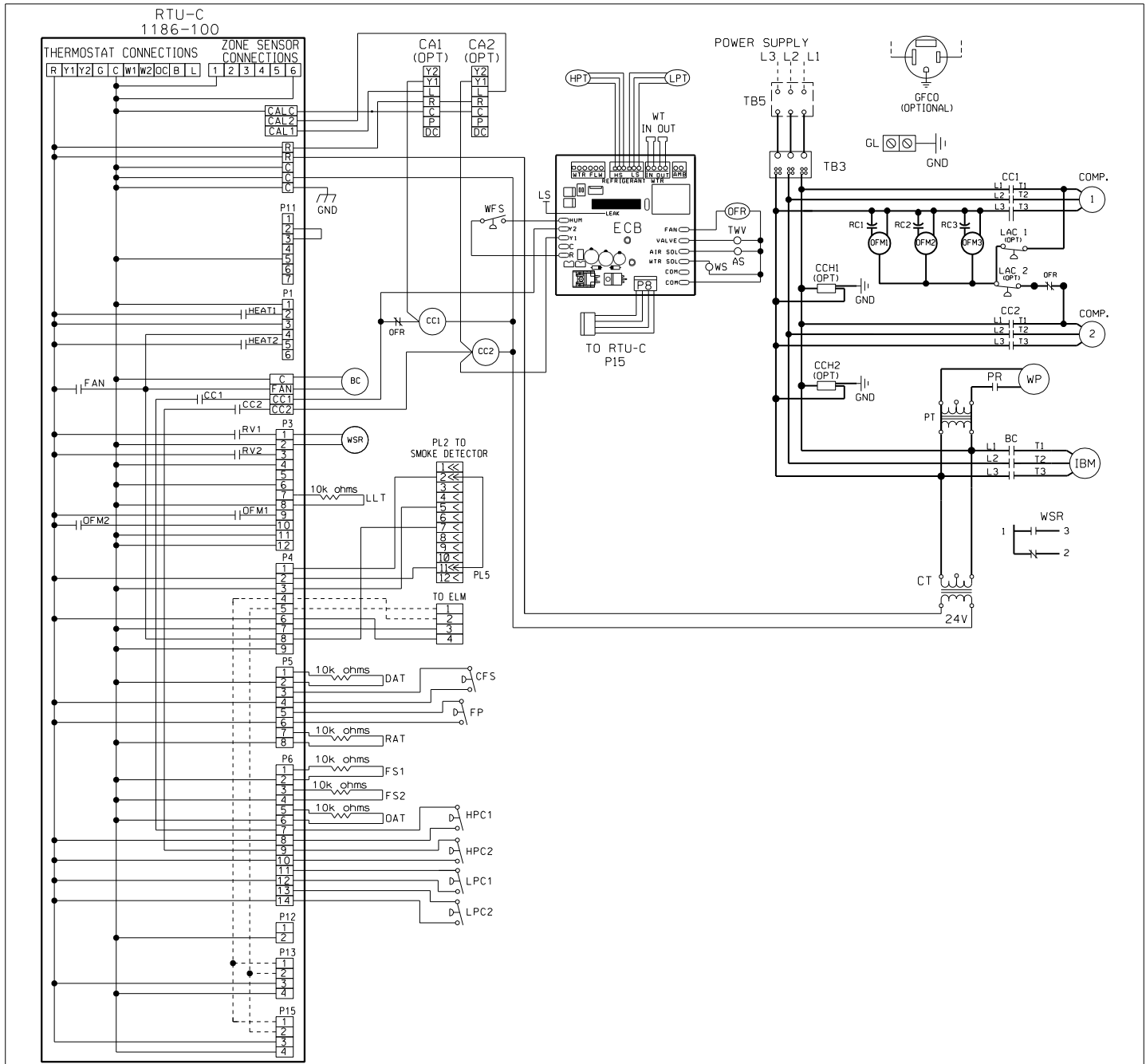

COMPONENT CODE

AS	AIR SOLENOID	HPT	HIGH PRESSURE TRANSDUCER	TB	TERMINAL BLOCK
BC	BLOWER CONTACTOR	IBM	INDOOR BLOWER MOTOR	TWV	THREE-WAY VALVE
CA	COMFORT ALERT MODULE			WFS	WATER FLOW SWITCH
CC	COMPRESSOR CONTACTOR	IFC	INTEGRATED FURNACE CONTROL	WP	WATER PUMP
CCH	CRANKCASE HEATER	LAC	LOW AMBIENT COOLING CONTROL	WS	WATER SOLENOID
COMP	COMPRESSOR	LLT	LIQUID LINE TEMPERATURE	WSR	WATER SHUTOFF RELAY
CT	CONTROL TRANSFORMER	LPC	LOW PRESSURE CONTROL	WT	WATER TEMPERATURE SENSER
DAT	DISCHARGE AIR SENSOR	LPT	LOW PRESSURE TRANSDUCER	▲	WIRE NUT
DISC	DISCONNECT SWITCH	LS	LEAK SENSOR		
ECB	ESYNC CONTROL BOARD	OAT	OUTSIDE AIR SENSOR		
FP	FAN PROVING	OFM	OUTDOOR FAN MOTOR		
FS	FREEZE SENSOR	OFR	OUTDOOR FAN RELAY		
GFCO	GROUND FAULT CONVENIENCE OUTLET	PL	PLUG		
GL	GROUND LUG	PR	PUMP RELAY		
GND	GROUND	PT	POWER TRANSFORMER		
HPC	HIGH PRESSURE CONTROL	RAT	RETURN AIR SENSOR		
		RC	RUN CAPACITOR		
		RTU-C	ROOFTOP UNIT CONTROL		

WIRING INFORMATION

LINE VOLTAGE
 -FACTORY STANDARD _____
 -FACTORY OPTION _____
 -FIELD INSTALLED - - - - -

LOW VOLTAGE
 -FACTORY STANDARD _____
 -FACTORY OPTION _____
 -FIELD INSTALLED - - - - -

REPLACEMENT WIRE
 -MUST BE THE SAME SIZE AND TYPE OF INSULATION AS ORIGINAL (105° C MIN.)

WARNING
 -CABINET MUST BE PERMANENTLY GROUNDED AND CONFORM TO I.E.C., N.E.C., C.E.C., AND LOCAL CODES AS APPLICABLE.

WIRE COLOR CODE

BK	BLACK	O	ORANGE
BR	BROWN	PR	PURPLE
BL	BLUE	R	RED
G	GREEN	W	WHITE
GY	GRAY	Y	YELLOW

WIRING SCHEMATIC

RLHL-D180
 460V 3 PH, 60 HZ.
 PACKAGED A/C W/RTU-C

DR. BY	APP. BY	DATE	DWG. NO.	REV
		1-7-13	90-104655-04	00

BEFORE PURCHASING THIS APPLIANCE, READ IMPORTANT ENERGY COST AND EFFICIENCY INFORMATION AVAILABLE FROM YOUR RETAILER.

GENERAL TERMS OF LIMITED WARRANTY*

Ruud will furnish a replacement for any part of this product which fails in normal use and service within the applicable periods stated, in accordance with the terms of the limited warranty.

Compressor	
3 Phase, Commercial Applications.....	Five (5) Years
Parts	
3 Phase, Commercial Applications	One (1) Year

***For complete details of the Limited and Conditional Warranties, including applicable terms and conditions, contact your local contractor or the Manufacturer for a copy of the product warranty certificate.**



In keeping with its policy of continuous progress and product improvement, Ruud reserves the right to make changes without notice.

Ruud Heating, Cooling & Water Heating • P.O. Box 17010
Fort Smith, Arkansas 72917 • www.ruud.com

Ruud Canada • 125 Edgeware Road, Unit 1
Brampton, Ontario • L6Y 0P5

RELY ON RUUD.™

PRINTED IN U.S.A 10/13 QG FORM NO. S22-968