

Extra Low Profile Unit Cooler

Publication No. 119.6

August, 2012



- **Applications**

The **Ceiling-Temp** unit cooler is designed for use in walk-in coolers and freezers with low headroom clearance. It's extra low height allows more product to be stored on shelves. The dual air flow design provides even temperatures throughout the box.

- **Sizes**

There are twenty models available, ranging in capacity from 4,800 to 25,000 BTUH @ 10° TD.

- **Coil**

The coil is constructed from seamless Copper tubes which are staggered and mechanically expanded into heavy gauge, corrugated, Aluminum fins, assuring maximum heat transfer. Optionally available with Copper or phenolic coated fins (phenolic fins are for air defrost only).

- **Housing**

Rust free heavy gauge textured Aluminum is standard. Optionally available with white enamel coating.

- **Electrical**

Available in 115V, 208-230V and 460V/1. All components are factory wired to terminal strips and are UL and CUL listed.

- **Motors / Fans**

Fan motors and blades can be easily accessed by lowering the hinged drain pan. All motors are permanently lubricated with thermal overload protection. Optional high efficiency PSC motors or ECM motors are available in 115V or 208-230V/1 only.

- **Defrost**

All models are available in air and electric defrost designs. Air defrost units are suitable for use in coolers down to 35°F. Electric defrost units are designed for use in rooms down to -10°F.

Specifications

AIR DEFROST Models

	MODEL NUMBER	BTUH @ +25°F S.T.		CFM	SP* MOTOR AMPS		PSC* MOTOR AMPS		ECM* MOTOR AMPS	
		10°T.D.	15°T.D.		115/1	208-230/1	115/1	208-230/1	115/1	208-230/1
8 FPI	CTA38-75	7,500	11,250	1,455	3.3	1.7	1.5	0.9	1.74	0.87
	CTA38-88	8,800	13,200	1,305	3.3	1.7	1.5	0.9	1.74	0.87
	CTA38-98	9,800	14,700	1,200	3.3	1.7	1.5	0.9	1.74	0.87
	CTA48-112	11,200	16,800	2,120	4.4	2.2	2.0	1.2	2.32	1.16
	CTA48-130	13,000	19,500	1,920	4.4	2.2	2.0	1.2	2.32	1.16
	CTA48-150	15,000	22,500	1,760	4.4	2.2	2.0	1.2	2.32	1.16
	CTA58-162	16,200	24,300	2,320	5.5	2.8	2.5	1.5	2.90	1.45
	CTA48-210	21,000	31,500	1,820	4.4	2.2	2.0	1.2	2.32	1.16
	CTA58-230	23,000	34,500	2,650	5.5	2.8	2.5	1.5	2.90	1.45
	CTA68-250	25,000	37,500	2,970	6.6	3.3	3.0	1.8	3.48	1.74
6 FPI	CTA36-64	6,400	9,600	1,560	3.3	1.7	1.5	0.9	1.74	0.87
	CTA36-82	8,200	12,300	1,425	3.3	1.7	1.5	0.9	1.74	0.87
	CTA36-93	9,300	13,950	1,305	3.3	1.7	1.5	0.9	1.74	0.87
	CTA46-100	10,000	15,000	2,160	4.4	2.2	2.0	1.2	2.32	1.16
	CTA46-123	12,300	18,450	2,040	4.4	2.2	2.0	1.2	2.32	1.16
	CTA46-140	14,000	21,000	1,920	4.4	2.2	2.0	1.2	2.32	1.16
	CTA56-157	15,700	23,500	2,360	5.5	2.8	2.5	1.5	2.90	1.45
	CTA46-190	19,000	28,500	1,940	4.4	2.2	2.0	1.2	2.32	1.16
	CTA56-208	20,800	31,200	2,850	5.5	2.8	2.5	1.5	2.90	1.45
	CTA66-232	23,200	34,800	2,970	6.6	3.3	3.0	1.8	3.48	1.74

SP* = Shaded Pole motor(s) PSC* = Permanent Split Capacitor(s) EC* = Electronically Commutated Motor(s)
Standard voltage for CTA models is 115/1/60

ELECTRIC DEFROST Models

	MODEL NUMBER	BTUH @ 10°T.D.		CFM	SP* MOTOR		PSC* MOTOR		ECM* MOTOR		DEFROST WATTS	DEFROST AMPS	
		-20°S.T.	+15°T.D.		115/1	208-230/1	115/1	208-230/1	115/1	208-230/1		208-230/1	460/1
6 FPI	CTE36-53	5,300	6,360	1440	3.3	1.7	1.5	0.9	1.74	0.87	2070	9.0	4.5
	CTE36-62	6,200	7,440	1290	3.3	1.7	1.5	0.9	1.74	0.87	2070	9.0	4.5
	CTE36-69	6,900	8,200	1245	3.3	1.7	1.5	0.9	1.74	0.87	2070	9.0	4.5
	CTE46-77	7,700	9,240	2075	4.4	2.2	2.0	1.2	2.32	1.16	2990	13.0	6.5
	CTE46-90	9,000	10,800	1860	4.4	2.2	2.0	1.2	2.32	1.16	2990	13.0	6.5
	CTE46-100	10,000	12,000	1740	4.4	2.2	2.0	1.2	2.32	1.16	2990	13.0	6.5
	CTE56-125	12,500	15,000	2160	5.5	2.8	2.5	1.5	2.90	1.45	3910	17.0	8.5
	CTE46-140	14,000	16,800	1820	4.4	2.2	2.0	1.2	2.32	1.16	3910	17.0	8.5
	CTE56-160	16,000	19,200	2550	5.5	2.8	2.5	1.5	2.90	1.45	3910	17.0	8.5
	CTE66-218	21,800	23,200	3000	6.6	3.3	3.0	1.8	3.48	1.74	3910	17.0	8.5
4 FPI	CTE34-48	4,800	5,760	1500	3.3	1.7	1.5	0.9	1.74	0.87	2070	9.0	4.5
	CTE34-58	5,800	6,960	1395	3.3	1.7	1.5	0.9	1.74	0.87	2070	9.0	4.5
	CTE34-65	6,500	7,800	1350	3.3	1.7	1.5	0.9	1.74	0.87	2070	9.0	4.5
	CTE44-72	7,200	8,640	2120	4.4	2.2	2.0	1.2	2.32	1.16	2990	13.0	6.5
	CTE44-84	8,400	10,080	1980	4.4	2.2	2.0	1.2	2.32	1.16	2990	13.0	6.5
	CTE44-95	9,500	11,400	1900	4.4	2.2	2.0	1.2	2.32	1.16	2990	13.0	6.5
	CTE54-115	11,500	13,800	2280	5.5	2.8	2.5	1.5	2.90	1.45	3910	17.0	8.5
	CTE44-128	12,800	15,360	1940	4.4	2.2	2.0	1.2	2.32	1.16	3910	17.0	8.5
	CTE54-145	14,500	17,400	2650	5.5	2.8	2.5	1.5	2.90	1.45	3910	17.0	8.5
	CTE64-173	17,300	20,760	3080	6.6	3.3	3.0	1.8	3.48	1.74	3910	17.0	8.5

SP* = Shaded Pole motor(s) PSC* = Permanent Split Capacitor(s) EC* = Electronically Commutated Motor(s)
230V/1 motors are suitable for 208V operation. Standard voltage for CTE models is 208-230/1/60

Dimensions

AIR DEFROST Models

	MODEL NUMBER	DIMENSIONS(IN)					TXV TYPE	CONNECTIONS(IN)		SHIP WT. (LBS)
		L	W	H	A	B		LIQ. (ODS)	SUCT. (ODS)	
8 FPI	CTA38-75	58-1/2	28-3/4	9	24	24	EXT	1/2	5/8	95
	CTA38-88	58-1/2	28-3/4	9	24	24	EXT	1/2	5/8	100
	CTA38-98	58-1/2	28-3/4	9	24	24	EXT	1/2	5/8	105
	CTA48-112	82-1/2	28-3/4	9-3/4	36	36	EXT	1/2	7/8	125
	CTA48-130	82-1/2	28-3/4	9-3/4	36	36	EXT	1/2	7/8	130
	CTA48-150	82-1/2	28-3/4	9-3/4	36	36	EXT	1/2	7/8	135
	CTA58-162	106-1/2	28-3/4	9-3/4	48	48	EXT	1/2	7/8	150
	CTA48-210	106-1/2	28-3/4	11-1/4	48	48	EXT	1/2	7/8	155
	CTA58-230	106-1/2	28-3/4	11-1/4	48	48	EXT	1/2	7/8	165
CTA68-250	106-1/2	28-3/4	11-1/4	48	48	EXT	1/2	1-1/8	185	
6 FPI	CTA36-64	58-1/2	28-3/4	9	24	24	EXT	1/2	5/8	90
	CTA36-82	58-1/2	28-3/4	9	24	24	EXT	1/2	5/8	95
	CTA36-93	58-1/2	28-3/4	9	24	24	EXT	1/2	5/8	100
	CTA46-100	82-1/2	28-3/4	9-3/4	36	36	EXT	1/2	7/8	120
	CTA46-123	82-1/2	28-3/4	9-3/4	36	36	EXT	1/2	7/8	125
	CTA46-140	82-1/2	28-3/4	9-3/4	36	36	EXT	1/2	7/8	130
	CTA56-157	106-1/2	28-3/4	9-3/4	48	48	EXT	1/2	7/8	145
	CTA46-190	106-1/2	28-3/4	11-1/4	48	48	EXT	1/2	7/8	150
	CTA56-208	106-1/2	28-3/4	11-1/4	48	48	EXT	1/2	7/8	160
CTA66-232	106-1/2	28-3/4	11-1/4	48	48	EXT	1/2	1-1/8	180	

ELECTRIC DEFROST Models

	MODEL NUMBER	DIMENSIONS (IN)					TXV TYPE	CONNECTIONS(IN)		SHIP WT. (LBS)
		L	W	H	A	B		LIQ. (ODS)	SUCT. (ODS)	
6 FPI	CTE36-53	58-1/2	28-3/4	9	24	24	EXT	1/2	5/8	95
	CTE36-62	58-1/2	28-3/4	9	24	24	EXT	1/2	5/8	100
	CTE36-69	58-1/2	28-3/4	9	24	24	EXT	1/2	5/8	105
	CTE46-77	82-1/2	28-3/4	9-3/4	36	36	EXT	1/2	7/8	125
	CTE46-90	82-1/2	28-3/4	9-3/4	36	36	EXT	1/2	7/8	130
	CTE46-100	82-1/2	28-3/4	9-3/4	36	36	EXT	1/2	7/8	135
	CTE56-125	106-1/2	28-3/4	9-3/4	48	48	EXT	1/2	7/8	150
	CTE46-140	106-1/2	28-3/4	11-1/4	48	48	EXT	1/2	7/8	155
	CTE56-160	106-1/2	28-3/4	11-1/4	48	48	EXT	1/2	7/8	165
CTE66-218	106-1/2	28-3/4	11-1/4	48	48	EXT	1/2	1-1/8	185	
4 FPI	CTE34-48	58-1/2	28-3/4	9	24	24	EXT	1/2	5/8	90
	CTE34-58	58-1/2	28-3/4	9	24	24	EXT	1/2	5/8	95
	CTE34-65	58-1/2	28-3/4	9	24	24	EXT	1/2	5/8	100
	CTE44-72	82-1/2	28-3/4	9-3/4	36	36	EXT	1/2	7/8	120
	CTE44-84	82-1/2	28-3/4	9-3/4	36	36	EXT	1/2	7/8	125
	CTE44-95	82-1/2	28-3/4	9-3/4	36	36	EXT	1/2	7/8	130
	CTE54-115	106-1/2	28-3/4	9-3/4	48	48	EXT	1/2	7/8	145
	CTE44-128	106-1/2	28-3/4	11-1/4	48	48	EXT	1/2	7/8	150
	CTE54-145	106-1/2	28-3/4	11-1/4	48	48	EXT	1/2	7/8	160
CTE64-173	106-1/2	28-3/4	11-1/4	48	48	EXT	1/2	1-1/8	180	

Dimensions

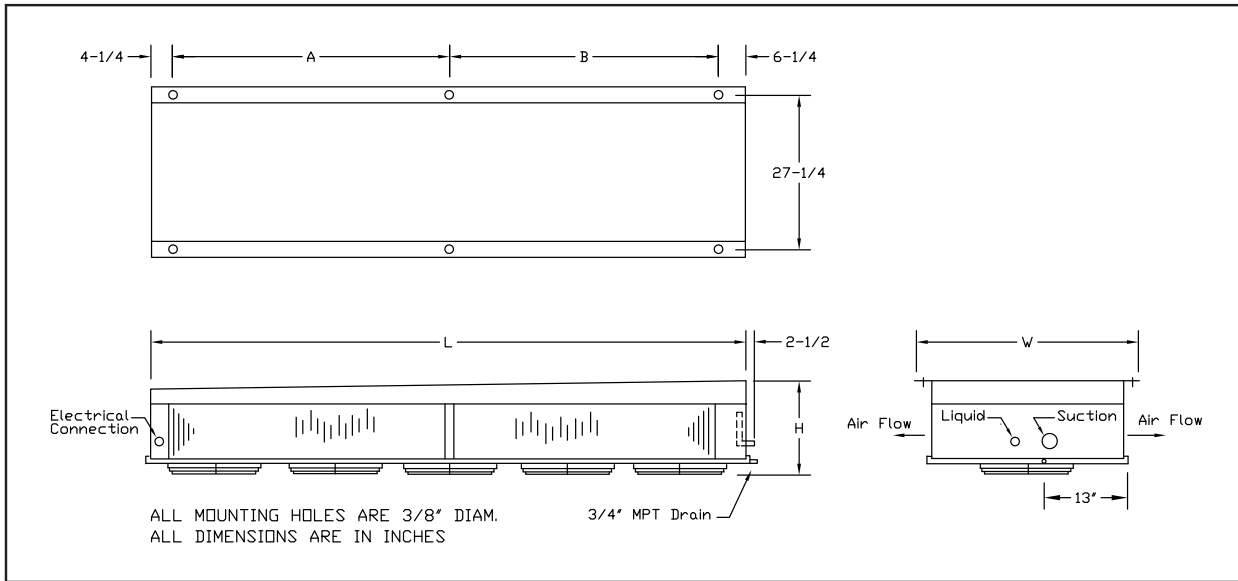

Energy Savings Analysis

Energy Savings per Motor by Changing to More Efficient Unit Cooler Motors (Based on Energy Cost of \$0.10 per kWh)

16 Watt SP, PSC and ECM (SP = Shaded Pole motor, PSC = Permanent split Capacitor Motor, EC = Electronically Commutated Motor)

Motor Change	Standard Motor Power Watts/Mtr	"Change to" Motor Power Watts/Mtr	Power Reduction Watts/Mtr	Run Time Hrs/Day	Motor Energy Savings kWh/Yr	Motor Energy Savings \$/Yr	Reduced Box Load MBTU/Yr	Cond. Unit EER	Cond. Unit Energy Savings kWh/Yr	Cond. Unit Energy Savings \$/Yr	Total Savings \$/Yr	Pay back Yrs
SP to PSC	75	51	24	22	193	19	658	5.2	126	13	32	1.0
SP to EC	75	35	40	22	321	32	1,096	5.2	211	21	53	2.0
PSC to EC	51	35	16	22	128	13	438	5.2	84	8	21	3.4

Subtract 6% from total savings for medium temperature 24 run hours per day.

Nomenclature

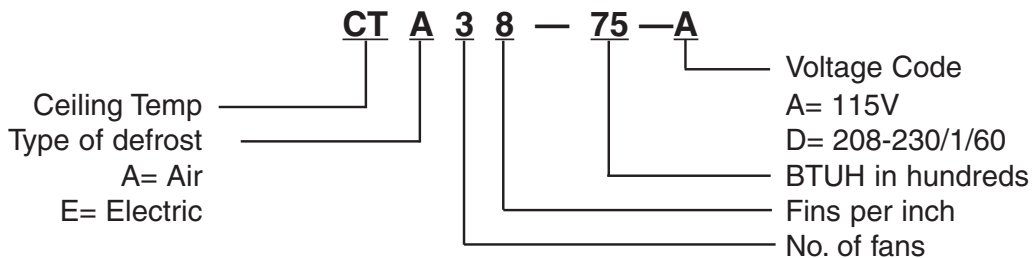

Visit us on the Web: <http://coldzone.htpgusa.com>