

CCM Series

CCM CoolMaster Evaporator

Air Defrost



CCM model unit coolers are designed for commercial and industrial walk-in coolers and industrial walk-in coolers and refrigerated warehouses. Time-tested for many years, these virtually maintenance-free unit coolers are built with Kramer reliability.

These units are suitable for maintaining room temperature of +35° and higher.

Features:



- Corrosion resistant casing, sturdy construction.
- Coils constructed of Copper tubes and Aluminum fins.
- Industrial evaporators with 6 FPI.
- Pitched drain pan for positive condensate drainage.
- Single phase motors have built-in overload protection.
- Dependable ratings based on laboratory tests.

Performance Data

6 FPI	MODEL	Capacity @ 10 T.D.			CFM	Air Throw (3)	Motors		Total Fan Motor Amps (4)	
		Evaporator Temperature - °F					No.	H.P.	230-3-60	460-3-60
		+40° (1)	+30° (2)	+25° (2)						
	CCM-520D	55950	51950	51400	8385	50	2	1/2	3.6	1.8
	CCM-710D	77050	71600	70825	8190	50	2	1/2	3.6	1.8
	CCM-970D	105700	98200	97125	12800	100	2	3/4	7.0	3.5
	CCM-1220D	133000	123600	122250	14600	100	2	3/4	7.0	3.5
	CCM-1390D	151700	140900	139400	14100	100	2	3/4	7.0	3.5
	CCM-1550D	167900	156400	154500	19700	100	3	3/4	10.5	5.3
	CCM-1810D	196400	182400	180450	19000	100	3	3/4	10.5	5.3
	CCM-2060D	223700	207900	205560	24600	100	4	3/4	14.0	7.0
	CCM-2400D	261000	242500	239900	23700	100	4	3/4	14.0	7.0

1. Non-frosting conditions. 2. Frosting conditions. 3. Unrestricted airflow.
4. Single phase motors are available, contact factory.

CCM CoolMaster Evaporator

Dimensional Data

MODEL	Dimensions(in)								Refrig. Charge (lbs)	Approx. Ship Weight (lbs.)
	A	B	C	D	E	F	G	H		
CCM-520D	3-1/4	26	31-3/4	42-1/2	58	75	2-1/2	7-1/2	8	500
CCM-710D	3-1/4	26	31-3/4	42-1/2	58	75	2-1/2	7-1/2	13	600
CCM-970D	3-7/8	26	32-3/8	42-1/2	94	111	2-1/2	7-1/2	16	900
CCM-1220D	3-7/8	26	32-3/8	42-1/2	94	111	2-1/2	7-1/2	19	1000
CCM-1390D	5-3/4	28	36-1/8	42-1/2	94	111	2-3/8	7-1/2	25	1150
CCM-1550D	7-1/2	28-1/4	41-3/4	47-3/4	113-1/4	136	6	11-3/8	25	1500
CCM-1810D	7-1/2	28-1/4	41-3/4	47-3/4	113-1/4	136	6	11-3/8	33	1700
CCM-2060D	7-1/2	28-1/4	41-3/4	47-3/4	151-1/4	174	6	11-3/8	33	2000
CCM-2400D	7-1/2	28-1/4	41-3/4	47-3/4	151-1/4	174	6	11-3/8	43	2200

Connection Data

MODEL	Connections (in) (6)			
	Suction O.D.	Liquid O.D.	Ext. Equal O.D.	Drain MPT
CCM-520D	1-3/8	7/8	1/4	3/4
CCM-710D	1-5/8	1-1/8	1/4	3/4
CCM-970D	1-5/8	1-1/8	1/4	3/4
CCM-1220D	2-1/8	1-1/8	1/4	3/4
CCM-1390D	2-1/8	1-1/8	1/4	3/4
CCM-1550D	2-1/8	1-3/8	1/4	1
CCM-1810D	2-1/8	1-3/8	1/4	1
CCM-2060D	2-1/8	1-3/8	1/4	1
CCM-2400D	(2) 2-1/8	(2) 1-1/8	(2) 1/4	1

MODELS: CCM-520, 710, 970, 1220 & 1390

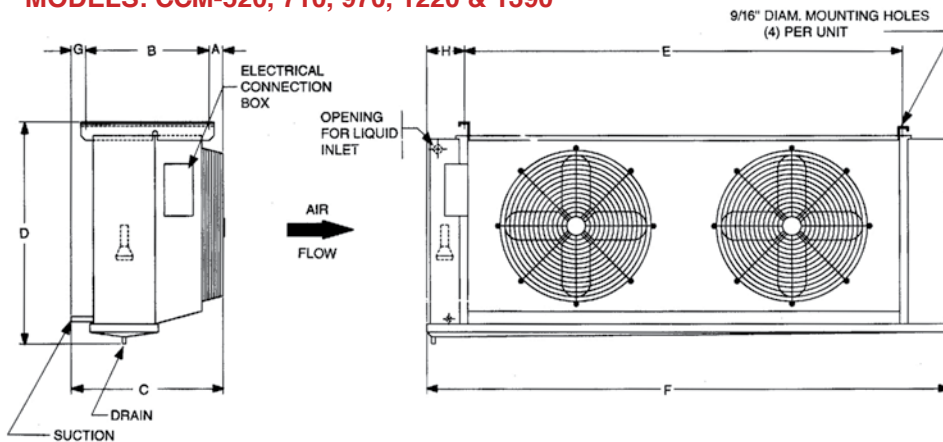

Connection sizes are based on R-22, and may vary from catalog ratings when actual site operating conditions are provided at time of order.

NOTES:- LEFT HAND COIL IS SHOWN, AND IS STANDARD. RIGHT HAND COIL MUST BE SPECIFIED WHEN ORDERING.
- ALL DIMENSIONS ARE IN INCHES.

MODELS: CCM-1550, 1810, 2060 & 2400

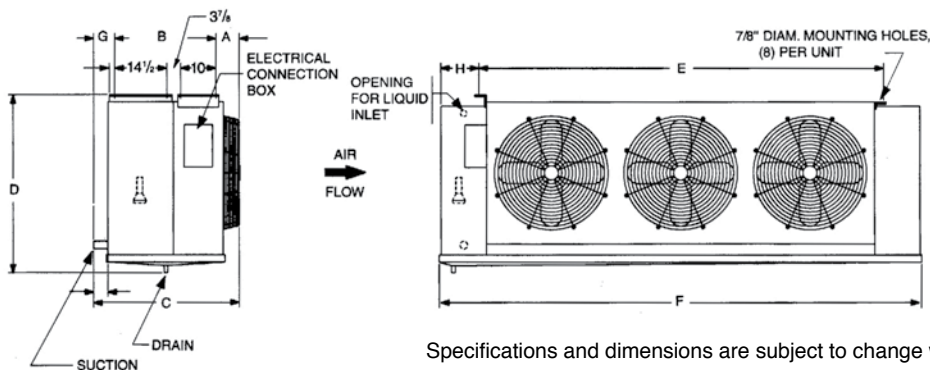

NOTES:- LEFT HAND COIL IS SHOWN, AND IS STANDARD. RIGHT HAND COIL MUST BE SPECIFIED WHEN ORDERING.
- ALL DIMENSIONS ARE IN INCHES.
- MODEL CCM-2400 HAS 2 SUCTION AND 2 LIQUID CONNECTIONS.

Specifications and dimensions are subject to change without notice.

KM-CCM-0412A