

CM Series

CM CoolMaster Evaporator

Air Defrost



CM model unit coolers are designed for commercial and industrial walk-in coolers and industrial walk-in coolers and refrigerated warehouses. Time-tested for many years, these virtually maintenance-free unit coolers are built with Kramer reliability.

These units are suitable for maintaining room temperature of +35° and higher.

Features:



- Corrosion resistant casing, sturdy construction.
- Coils constructed of Copper tubes and Aluminum fins.
- Industrial evaporators with 4 FPI.
- Pitched drain pan for positive condensate drainage.
- Single phase motors have built-in overload protection.
- Dependable ratings based on laboratory tests.

Performance Data

4 FPI	MODEL	Capacity @ 10 T.D.			CFM	Air Throw (3)	Motors		Total Fan Motor Amps (4)	
		Evaporator Temperature - °F					No.	H.P.	230-3-60	460-3-60
		+40° (1)	+30° (2)	+25° (2)						
	CM-450D	49500	46000	45500	8600	50	2	1/2	3.6	1.8
	CM-620D	68200	63300	62700	8400	50	2	1/2	3.6	1.8
	CM-850D	93500	86300	85500	13100	100	2	3/4	7.0	3.5
	CM-1100D	117700	109000	107900	15000	100	2	3/4	7.0	3.5
	CM-1250D	134000	124700	123500	14500	100	2	3/4	7.0	3.5
	CM-1350D	148500	138000	136600	20200	100	3	3/4	10.5	5.3
	CM-1600D	173800	161500	159900	19500	100	3	3/4	10.5	5.3
	CM-1800D	198000	184000	182200	25200	100	4	3/4	14.0	7.0
	CM-2100D	231000	214600	212500	24300	100	4	3/4	14.0	7.0

1. Non-frosting conditions. 2. Frosting conditions. 3. Unrestricted airflow.
4. Single phase motors are available, contact factory.

Dimensional Data

MODEL	Dimensions (in)								Refrig. Charge (lbs)	Approx. Ship Weight (lbs)
	A	B	C	D	E	F	G	H		
CM-450D	3-1/4	26	31-3/4	42-1/2	58	75	2-1/2	7-1/2	8	500
CM-620D	3-1/4	26	31-3/4	42-1/2	58	75	2-1/2	7-1/2	13	600
CM-850D	3-7/8	26	32-3/8	42-1/2	94	111	2-1/2	7-1/2	16	900
CM-1100D	3-7/8	26	32-3/8	42-1/2	94	111	2-1/2	7-1/2	19	1000
CM-1250D	5-3/4	28	36-1/8	42-1/2	94	111	2-3/8	7-1/2	25	1150
CM-1350D	7-1/2	28-1/4	41-3/4	47-3/4	113-3/4	136	6	11-3/8	25	1500
CM-1600D	7-1/2	28-1/4	41-3/4	47-3/4	113-3/4	136	6	11-3/8	33	1700
CM-1800D	7-1/2	28-1/4	41-3/4	47-3/4	151-1/4	174	6	11-3/8	33	2000
CM-2100D	7-1/2	28-1/4	41-3/4	47-3/4	151-1/4	174	6	11-3/8	43	2200

Connection Data

MODEL	Connections (in) (6)			
	Suction O.D.	Liquid O.D.	Ext. Equal O.D.	Drain MPT
CM-450D	1-3/8	7/8	1/4	3/4
CM-620D	1-5/8	1-1/8	1/4	3/4
CM-850D	1-5/8	1-1/8	1/4	3/4
CM-1100D	2-1/8	1-1/8	1/4	3/4
CM-1250D	2-1/8	1-1/8	1/4	3/4
CM-1350D	2-1/8	1-3/8	1/4	1
CM-1600D	2-1/8	1-3/8	1/4	1
CM-1800D	2-1/8	1-3/8	1/4	1
CM-2100D	(2) 2-1/8	(2) 2-1/8	(2) 1/4	1

MODELS: CM-450, 620, 850 & 1250

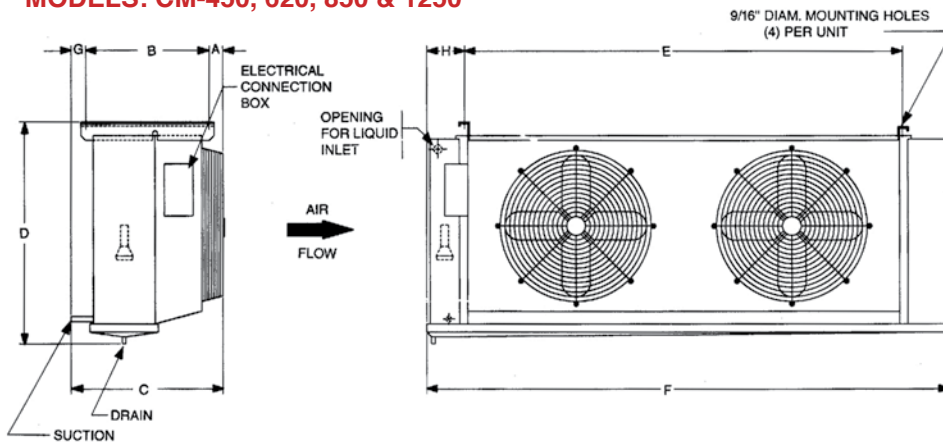

Connection sizes are based on R-22, and may vary from catalog ratings when actual site operating conditions are provided at time of order.

NOTES:- LEFT HAND COIL IS SHOWN, AND IS STANDARD. RIGHT HAND COIL MUST BE SPECIFIED WHEN ORDERING.
- ALL DIMENSIONS ARE IN INCHES.

MODELS: CM-1350, 1600, 1800 & 2100

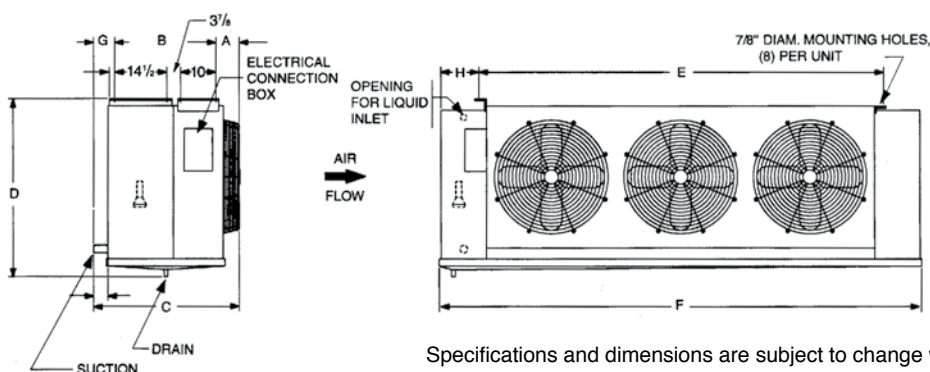

NOTES:- LEFT HAND COIL IS SHOWN, AND IS STANDARD. RIGHT HAND COIL MUST BE SPECIFIED WHEN ORDERING.
- ALL DIMENSIONS ARE IN INCHES.
- MODEL CM-2100 HAS 2 SUCTION AND 2 LIQUID CONNECTIONS.

Specifications and dimensions are subject to change without notice.