



Publication No. WT-WVL-0617A
Replaces WT-WVL-0814A

WV-Series 20 to 80 HP Air-Cooled Condensing Units



WV-Series



The **outdoor housing** of the unit has been designed for the serviceman. Removing only a few screws allows complete removal of the compressor housing top panel, side panel and corner post. This gives the mechanic quick, unrestricted access to the compressor, as well as all controls and components located within the compressor compartment. Or, just a single panel can be removed, depending on the requirements of the service call.

The large control panel has abundant space for the controls you choose. The control layout is done in a logical fashion—easy to understand and work with. Each control and wire is clearly marked with a name or number as shown on the wiring diagram which is permanently affixed to the control panel door.

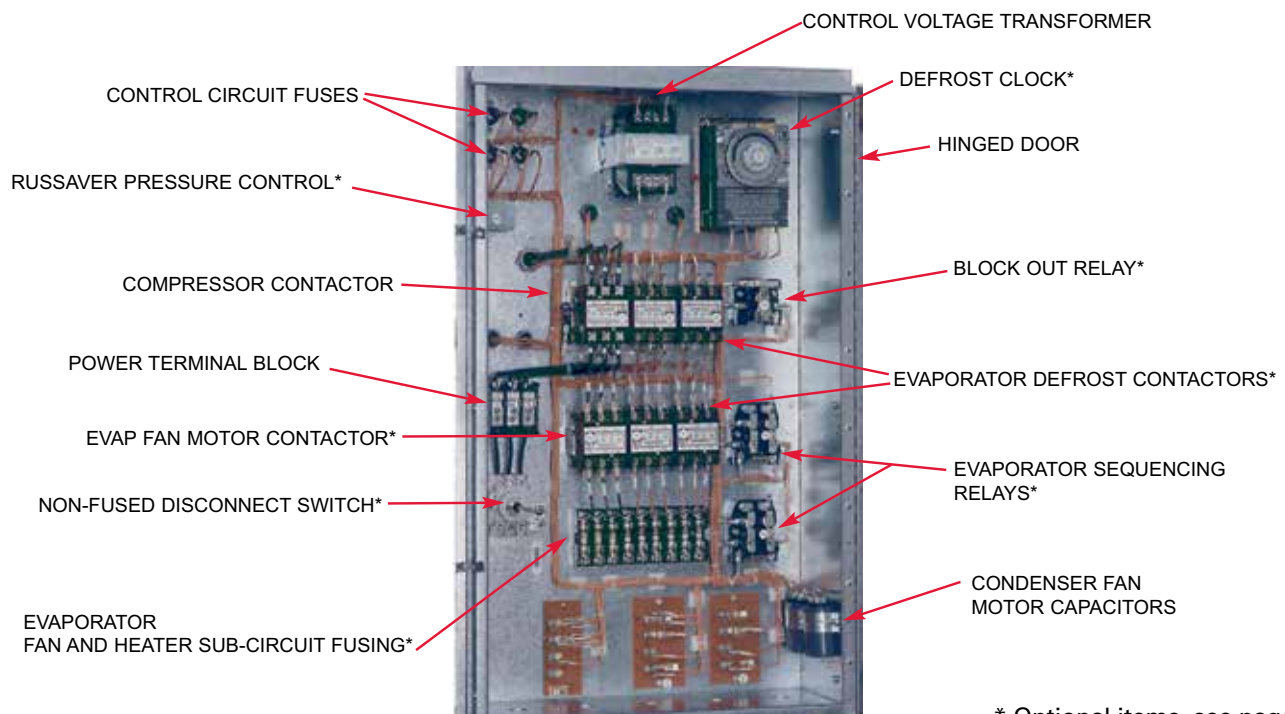

* Optional items, see page 3

Air Cooled Condensing Units 20 to 80 HP

MODEL NUMBER NOMENCLATURE

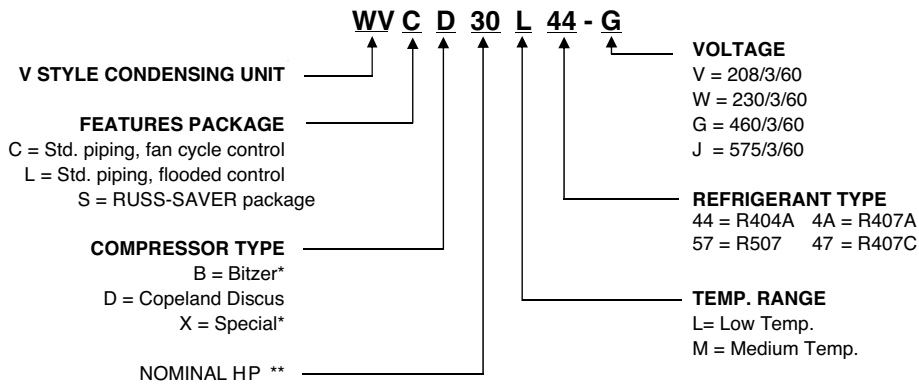

NOMINAL COMPRESSOR HP		
SINGLE COMP.	PARALLEL PIPING	DUAL PIPING
20 HP	24 (2)12 HP	18 (2)7.5 HP
25 HP	31 (2)15 HP	23 (2)10 HP
27 HP	41 (2)20 HP	26 (2)12 HP
30 HP	44 (2)22 HP	32 (2)15 HP
35 HP	51 (2)25 HP	42 (2)20 HP
40 HP	54 (2)27 HP	46 (2)22 HP
50 HP	61 (2)30 HP	52 (2)25 HP
60 HP	71 (2)35 HP	56 (2)27 HP
	81 (2)40 HP	62 (2)30 HP
		72 (2)35 HP
		82 (2)40 HP

	FEATURES AT A GLANCE	MODEL		
		WVC	WVL	WVS
ELECTRICAL COMPONENTS	Crankcase heater Oil failure control High - Low pressure control - manual (high)/automatic (low) reset Compressor contactor Control circuit fuses - standard 230/1 Power terminal block	STD	STD	STD
CONDENSER	Copper tubes with Aluminum fins Subcooling circuit Fan motor - overload protection Fan blade - individually balanced Fan guard - heavy duty resilient wire basket	STD	STD	STD
PIPING COMPONENTS	Suction line vibration eliminator Replaceable core liquid line filter / drier Suction line filter (replaceable core some models) Discharge line vibration eliminator High Pressure control hoses	STD	STD	STD
RECEIVER	Inlet and outlet isolation valves Pressure relief valve	STD	STD	STD
HOUSING	Mill galvanized steel with removable access panels Control panel with hinged door Heavy galvanized steel base rails	STD	STD	STD
LOW AMBIENT CONTROLS	Pressure fan cycling control Flooded condenser RUSS-SAVER — All ambient energy saver	STD N/A N/A	STD STD N/A	N/A N/A STD
TESTING	UL / cUL listed — all models Leak detection, dielectric and run tests Dry nitrogen holding charge	STD STD STD	STD STD STD	STD STD STD

- OPTIONS:**
- 4-year extended compressor protection plan
 - Air defrost time clock
 - Compressor unloading
 - Copper or coated condenser fins
 - Electric defrost components
 - Evaporator sub circuit fusing
 - Fused or non fused disconnect
 - Heated and insulated receiver
 - Hot Gas defrost components
 - Liquid line solenoid valve
 - Oil separator
 - Crankcase pressure regulator
 - Electronic oil safety control
 - Stainless steel superhoses
 - Suction accumulator

* Contact factory for details.

WV-Series

WITT-SAVER

The initial cost of quality refrigeration equipment is a substantial investment, but the costs of installation and operation are also formidable. Rising to the challenge, Witt engineers have designed the **WITT-SAVER** system to meet the highest standards of performance and reliability while effectively addressing the problem of these profit-draining costs. These systems are entirely factory pre-selected, consisting of a **WITT-SAVER** condensing unit from this catalog together with the appropriate unit cooler(s), expansion valve(s) and controls.

REDUCED INSTALLATION COSTS

The installation of a refrigeration system which uses **WITT-SAVER** requires a smaller refrigerant charge than equipment which utilizes other types of low ambient controls. The reduced charge requirements provided by **WITT-SAVER** afford substantial and immediate cost saving benefits.

REDUCED OPERATING COSTS

The most expensive part of an operating refrigeration system is the cost of energy to run the compressor. Day and night, year after year, the cost of electricity your equipment consumes is **unrelenting**. These dollars are pulled right from your bottom line.

The **WITT-SAVER** system is designed to furnish proper cooling in the summer months, yet still be flexible enough to take advantage of reduced ambient conditions. As the outside air temperature cools, head pressures are allowed to decrease. This results in increased efficiency, less energy usage and substantial savings of your money!

WITT-SAVER even saves money during hot weather.

The subcooling loop provided in the condenser of the **WITT-SAVER** condensing unit increases the system efficiency 1/2% for each degree of sub-cooling provided, thereby making the compressor's job easier. Combined with Copeland's energy efficient DISCUS compressors, **WITT-SAVER's** efficiency saves you money during summer operation and even more during the winter months.

Air Cooled Condensing Units 20 to 80 HP

WITT-SAVER

ENERGY SAVINGS CALCULATIONS

To estimate your average monthly savings:

- 1) Select a WITT-SAVER system that meets your refrigeration requirements.
- 2) Determine the Average Annual Outdoor Air Temperature from the table below.
- 3) Using the Projected Monthly Savings graph, locate the system nominal horsepower at the bottom of the graph (the nominal system horsepower can be derived from the model number nomenclature).
- 4) Go straight up to the appropriate Average Annual Outdoor Air Temperature curve, and then go horizontally to the left to determine your Estimated Monthly Average Savings.
- 5) To calculate your Estimated Monthly Saving for an energy cost other than \$0.10 KWH, divide the Estimated Monthly Savings by 0.10 and multiply by your local electric utility rate.
- 6) To determine your Estimated Yearly Savings, multiple the Estimated Monthly Savings number by 12.

AVERAGE ANNUAL OUTDOOR AIR TEMPERATURE

STATE & STATION	ANNUAL AVG. °F	STATE & STATION	ANNUAL AVG. °F	STATE & STATION	ANNUAL AVG. °F	STATE & STATION	ANNUAL AVG. °F
AL Mobile	70	IA Des Moines	50	NM Albuquerque	60	VT Burlington	45
AK Juneau	40	KS Wichita	55	NY Buffalo	45	VA Richmond	60
AZ Phoenix	70	KY Louisville	55	NY New York	55	WA Seattle	50
AR Little Rock	60	LA New Orleans	70	NC Charlotte	60	WV Charleston	55
CA Los Angeles	60	ME Portland	45	ND Bismarck	45	WI Milwaukee	45
CA San Francisco	55	MD Baltimore	55	OH Cleveland	50	WY Cheyenne	45
CO Denver	50	MA Boston	50	OH Columbus	50	CANADA	
CT Hartford	50	MI Detroit	50	OK Oklahoma City	60		
DE Wilmington	55	MN Sault St. Marie	40	OR Portland	55	ALB Calgary	40
D.C. Washington	55	MINneapolis	45	PA Philadelphia	50	B.C. Vancouver	50
FL Jacksonville	70	MS Jackson	65	RI Providence	50	MAN Winnipeg	35
FL Miami	75	MO St. Louis	55	SC Columbia	65	N.B. St. John	45
GA Atlanta	60	MT Great Falls	45	SD Sioux Falls	45	N.F. St. John's	40
HI Honolulu	75	NE Omaha	50	TN Nashville	60	N.S. Halifax	45
ID Boise	50	NV Reno	50	TX Dallas	65	ONT Toronto	45
IL Chicago	50	NH Concord	45	TX El Paso	65	QUE Montreal	45
IN Indianapolis	50	NJ Atlantic City	55	UT Salt Lake City	50	YUK Dawson	25

WITT-SAVER PROJECTED MONTHLY SAVINGS @ \$0.10/KWH

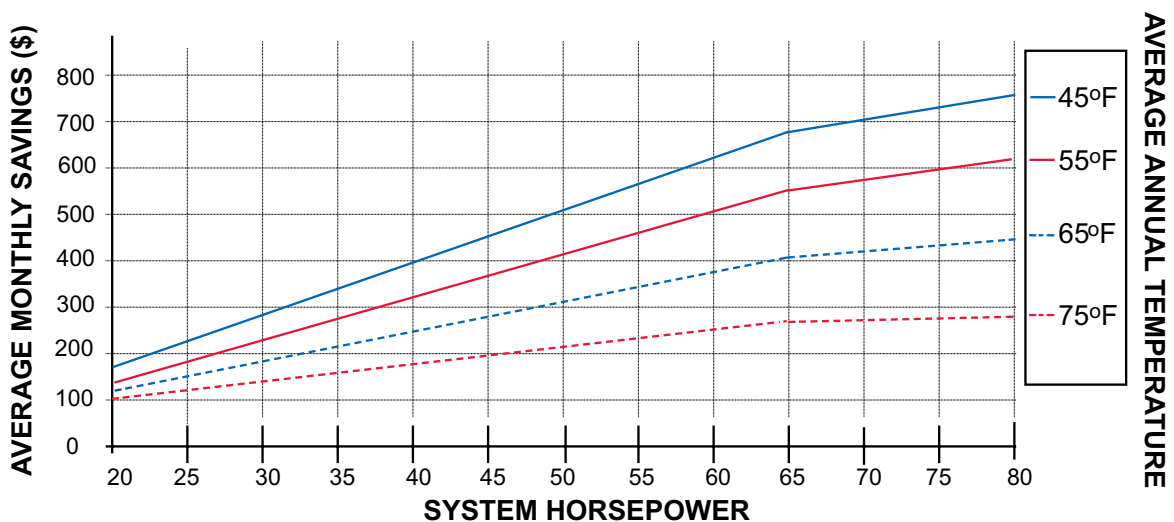

WV-Series

Capacity Data (BTUH) - Medium Temperature R404A Single Compressor

SUCTION TEMPERATURE

	MODEL NUMBER WVC/ WVL/ WVS	+45°F	+35°F	+25°F	+20°F	+10°F	0°F	-10°F
90°F AMBIENT	20M44	265.8	230.2	193.0	176.0	142.8	114.3	92.9
	25M44	292.1	251.8	212.1	192.9	157.0	125.9	101.7
	30M44	347.6	295.0	246.6	224.1	182.6	146.2	114.8
	35M44	443.7	374.2	311.7	283.1	231.2	186.0	147.2
	40M44	551.9	471.7	397.1	362.3	297.7	240.9	192.2

95°F AMBIENT	20M44	253.0	218.9	183.7	167.1	135.7	108.6	88.1
	25M44	277.6	239.3	201.6	183.3	149.2	119.6	96.6
	30M44	330.1	280.1	234.1	212.8	173.4	138.8	109.0
	35M44	422.1	356.0	296.5	269.3	219.9	176.9	140.0
	40M44	524.1	447.9	377.1	344.0	282.7	228.7	182.5

100°F AMBIENT	20M44	241.3	207.8	175.1	159.1	129.2	103.7	83.9
	25M44	264.3	227.9	192.0	174.6	142.1	113.9	92.0
	30M44	313.6	266.1	222.4	202.2	164.8	131.9	103.6
	35M44	402.3	339.3	282.6	256.7	209.6	168.6	133.5
	40M44	499.0	426.5	359.0	327.5	269.2	217.8	173.8

110°F AMBIENT	20M44	205.1	176.1	148.6	135.1	109.8	88.5	71.3
	25M44	224.9	193.9	163.3	148.5	120.9	96.9	78.3
	30M44	269.4	228.6	191.1	173.7	141.5	113.3	89.0
	35M44	346.2	292.0	243.2	220.9	180.4	145.1	114.8
	40M44	427.2	365.1	307.4	280.4	230.5	186.4	148.8

Medium temperature R404A models can be used with R22.

Multiply capacity of models by 1.02 to obtain approximate R22 capacity.

Medium temperature R404A models can be used with R407C.

Multiply capacity of models by .83 to obtain approximate R407C capacity.

See page 3 for complete nomenclature.

Air Cooled Condensing Units 20 to 80 HP

Capacity Data (BTUH) - Medium Temperature R404A Parallel / Dual Systems

SUCTION TEMPERATURE

	MODEL NUMBER WVC/WVL/WVS	+45°F	+35°F	+25°F	+20°F	+10°F	0°F	-10°F
90°F AMBIENT	18M44*	256.5	218.4	183.3	167.0	137.0	115.1	87.5
	23M44*	309.4	262.6	220.3	200.9	165.2	133.7	105.7
	24M44 / 26M44*	363.4	311.2	263.1	240.6	199.1	162.0	129.4
	31M44 / 32M44*	421.0	357.8	300.2	273.7	225.2	182.4	145.2
	41M44 / 42M44*	527.8	459.0	385.5	351.4	285.8	228.8	185.5
	51M44 / 52M44*	584.1	503.5	424.2	385.7	314.0	251.7	203.1
	61M44 / 62M44*	695.2	589.9	493.1	448.2	365.2	292.4	229.6
	71M44 / 72M44*	888.1	749.1	623.9	566.7	462.7	372.2	294.6
	81M44 / 82M44*	1,101.7	941.5	792.7	723.1	594.3	480.8	383.7
95°F AMBIENT	18M44*	243.3	207.2	173.9	158.4	129.9	109.2	83.0
	23M44*	294.1	249.6	209.4	190.9	157.0	127.0	100.4
	24M44 / 26M44*	345.1	295.5	249.8	228.4	189.0	153.8	122.8
	31M44 / 32M44*	400.5	340.4	285.6	260.4	214.2	173.5	138.1
	41M44 / 42M44*	503.0	436.9	366.2	333.7	271.1	217.1	176.1
	51M44 / 52M44*	555.2	478.6	403.2	366.6	298.4	239.2	193.0
	61M44 / 62M44*	660.2	560.2	468.2	425.6	346.8	277.6	218.0
	71M44 / 72M44*	844.2	712.0	593.0	538.6	439.8	353.8	280.0
	81M44 / 82M44*	1,048.2	895.8	754.2	688.0	565.4	457.4	365.0
100°F AMBIENT	18M44*	232.2	197.7	166.0	151.2	124.0	104.2	79.2
	23M44*	280.0	237.7	199.4	181.8	149.5	121.0	95.6
	24M44 / 26M44*	327.9	280.8	237.4	217.0	179.6	146.2	116.7
	31M44 / 32M44*	381.7	324.5	272.2	248.2	204.2	165.4	131.7
	41M44 / 42M44*	480.7	415.7	348.7	317.6	257.9	206.9	167.7
	51M44 / 52M44*	529.2	456.2	384.3	349.4	284.4	228.0	184.0
	61M44 / 62M44*	629.9	534.5	446.7	406.1	330.9	264.9	208.0
	71M44 / 72M44*	804.6	678.6	565.2	513.3	419.2	337.2	266.9
	81M44 / 82M44*	997.9	852.9	718.0	655.0	538.3	435.5	347.5
110°F AMBIENT	18M44*	198.3	168.9	141.8	129.1	105.9	89.0	67.7
	23M44*	238.3	202.2	169.7	154.7	127.2	102.9	81.4
	24M44 / 26M44*	281.7	241.2	203.9	186.4	154.3	125.6	100.3
	31M44 / 32M44*	328.5	279.2	234.2	213.6	175.7	142.3	113.3
	41M44 / 42M44*	414.4	356.8	300.2	272.3	220.4	177.4	143.7
	51M44 / 52M44*	454.8	392.0	330.3	300.3	244.4	196.0	158.1
	61M44 / 62M44*	542.7	460.5	384.9	349.9	285.1	228.2	179.2
	71M44 / 72M44*	688.1	580.3	483.3	439.0	358.5	288.4	228.2
	81M44 / 82M44*	849.1	725.6	611.0	557.3	458.0	370.5	295.7

*Dual compressor unit capacity is shown as combined total capacity of both systems.

Medium temperature R404A models can be used with R22 and R407C. See footnotes on page 6 for calculation.

See page 3 for complete nomenclature.

WV-Series

Capacity Data (BTUH) - Medium Temperature R407A Single Compressor

SUCTION TEMPERATURE

	MODEL NUMBER WVC/ WVL/ WVS	+45°F	+35°F	+25°F	+20°F	+10°F	5°F
90°F AMBIENT	20M4A	247.9	208.9	170.3	153.1	120.7	107.2
	25M4A	272.4	228.5	187.2	167.8	132.7	118.0
	30M4A	324.1	267.7	217.6	195.0	154.3	137.1
	35M4A	413.8	339.6	275.1	246.3	195.4	173.9
	40M4A	514.6	428.1	350.4	315.2	251.6	224.5
95°F AMBIENT	20M4A	235.9	198.7	162.1	145.4	114.7	101.9
	25M4A	258.9	217.2	177.9	159.5	126.1	112.1
	30M4A	307.8	254.2	206.6	185.1	146.5	130.2
	35M4A	393.6	323.1	261.7	234.3	185.8	165.4
	40M4A	488.7	406.5	332.8	299.3	238.9	213.2
100°F AMBIENT	20M4A	225.0	188.6	154.5	138.4	109.2	97.1
	25M4A	246.5	206.8	169.4	151.9	120.1	106.7
	30M4A	292.4	241.5	196.3	175.9	139.3	123.7
	35M4A	375.1	307.9	249.4	223.3	177.1	157.7
	40M4A	465.3	387.0	316.8	284.9	227.5	203.0
110°F AMBIENT	20M4A	191.3	159.8	131.1	117.5	92.8	82.7
	25M4A	209.7	176.0	144.1	129.2	102.2	90.8
	30M4A	251.2	207.5	168.6	151.1	119.6	106.2
	35M4A	322.8	265.0	214.6	192.2	152.4	135.7
	40M4A	398.4	331.3	271.3	243.9	194.8	173.8

Air Cooled Condensing Units 20 to 80 HP

Capacity Data (BTUH) - Medium Temperature R407A Parallel / Dual Systems

SUCTION TEMPERATURE

	MODEL NUMBER WVC/W VL/W VS	+45°F	+35°F	+25°F	+20°F	+10°F	5°F
90°F AMBIENT	18M4A*	239.2	198.2	161.8	145.3	115.8	105.1
	23M4A*	288.5	238.3	194.4	174.8	139.6	124.6
	24M4A / 26M4A*	338.9	282.4	232.2	209.3	168.2	150.5
	31M4A / 32M4A*	392.6	324.7	264.9	238.1	190.3	169.9
	41M4A / 42M4A*	492.2	416.5	340.2	305.7	241.5	214.6
	51M4A / 52M4A*	544.7	456.9	374.4	335.6	265.3	235.9
	61M4A / 62M4A*	648.3	535.3	435.2	389.9	308.6	274.2
	71M4A / 72M4A*	828.2	679.8	550.6	493.0	391.0	348.1
	81M4A / 82M4A*	1027.3	854.4	699.6	629.1	502.2	448.2
95°F AMBIENT	18M4A*	226.9	188.0	153.5	137.8	109.8	99.7
	23M4A*	274.2	226.5	184.8	166.1	132.7	118.4
	24M4A / 26M4A*	321.8	268.2	220.4	198.7	159.7	142.9
	31M4A / 32M4A*	373.5	308.9	252.0	226.5	181.0	161.6
	41M4A / 42M4A*	469.0	396.5	323.2	290.3	229.1	203.6
	51M4A / 52M4A*	517.7	434.3	355.8	318.9	252.1	224.1
	61M4A / 62M4A*	615.6	508.4	413.2	370.3	293.0	260.3
	71M4A / 72M4A*	787.2	646.1	523.3	468.6	371.6	330.9
	81M4A / 82M4A*	977.4	812.9	665.6	598.6	477.8	426.4
100°F AMBIENT	18M4A*	216.5	179.4	146.5	131.5	104.8	95.1
	23M4A*	261.1	215.7	176.0	158.2	126.3	112.8
	24M4A / 26M4A*	305.8	254.8	209.5	188.8	151.8	135.8
	31M4A / 32M4A*	355.9	294.5	240.2	215.9	172.5	154.1
	41M4A / 42M4A*	448.3	377.2	307.7	276.3	217.9	193.8
	51M4A / 52M4A*	493.5	414.0	339.1	304.0	240.3	213.6
	61M4A / 62M4A*	587.4	485.1	394.2	353.3	279.6	248.4
	71M4A / 72M4A*	750.3	615.8	498.8	446.6	354.2	315.4
	81M4A / 82M4A*	930.5	774.0	633.6	569.9	454.9	406.0
110°F AMBIENT	18M4A*	184.9	153.3	125.1	112.3	89.5	81.2
	23M4A*	222.2	183.5	149.8	134.6	107.5	95.9
	24M4A / 26M4A*	262.7	218.9	179.9	162.2	130.4	116.7
	31M4A / 32M4A*	306.3	253.4	206.7	185.8	148.5	132.6
	41M4A / 42M4A*	386.4	323.8	264.9	236.9	186.2	165.9
	51M4A / 52M4A*	424.1	355.7	291.5	261.3	206.5	183.6
	61M4A / 62M4A*	506.1	417.9	339.7	304.4	240.9	214.0
	71M4A / 72M4A*	641.7	526.6	426.5	381.9	302.9	269.7
	81M4A / 82M4A*	791.8	658.5	539.2	484.9	387.0	345.4

*Dual compressor unit capacity is shown as combined total capacity of both systems.

WV-Series

Capacity Data (BTUH) - Low Temperature R404A

SUCTION TEMPERATURE

	MODEL NUMBER VWC / WV / WVS	-5°F	-10°F	-15°F	-20°F	-25°F	-30°F	-40°F
90°F AMBIENT	27L44	173.7	143.0	128.8	114.7	102.1	89.4	66.9
	30L44	200.9	165.0	148.4	131.7	117.0	102.3	77.1
	44L44 / 46L44*	274.1	226.9	205.3	183.7	164.9	146.1	113.7
	54L44 / 56L44*	346.5	285.1	256.9	228.7	203.5	178.3	133.3
	61L44 / 62L44*	402.1	330.3	297.0	263.5	234.2	204.8	154.2

95°F AMBIENT	27L44	164.8	135.6	122.2	108.8	96.8	84.8	63.4
	30L44	190.9	156.8	141.0	125.1	111.2	97.2	73.2
	44L44 / 46L44*	260.3	215.4	194.9	174.4	156.6	138.7	107.9
	54L44 / 56L44*	329.6	271.2	244.4	217.6	193.6	169.6	126.8
	61L44 / 62L44*	381.8	313.6	282.0	250.2	222.4	194.4	146.4

100°F AMBIENT	27L44	157.3	129.4	116.6	103.8	92.4	80.9	60.5
	30L44	181.8	149.3	134.3	119.1	105.9	92.6	69.7
	44L44 / 46L44*	247.3	204.7	185.2	165.7	148.8	131.8	102.6
	54L44 / 56L44*	314.2	258.5	233.0	207.4	184.6	161.7	120.9
	61L44 / 62L44*	363.5	298.6	268.5	238.2	211.8	185.1	139.4

110°F AMBIENT	27L44	134.4	110.6	99.6	88.7	78.9	69.2	51.7
	30L44	154.7	127.1	114.3	101.4	90.1	78.8	59.3
	44L44 / 46L44*	212.5	175.8	159.1	142.4	127.8	113.2	88.1
	54L44 / 56L44*	270.3	222.4	200.5	178.5	158.8	139.1	104.0
	61L44 / 62L44*	311.2	255.6	229.9	204.0	181.3	158.5	119.4

*Dual compressor unit capacity is shown as combined total capacity of both systems.

Air Cooled Condensing Units 20 to 80 HP

Capacity Data (BTUH) - Low Temperature R407A

SUCTION TEMPERATURE

	MODEL NUMBER WVC/ WV L / WVS	-5°F	-10°F	-15°F	-20°F	-25°F	-30°F	-40°F
90°F AMBIENT	27L4A	131.6	103.7	89.2	75.7	64.1	53.2	35.5
	30L4A	152.2	119.6	102.8	86.9	73.4	60.9	40.9
	44L4A / 46L4A*	207.6	164.5	142.2	121.2	103.5	86.9	60.3
	54L4A / 56L4A*	262.5	206.7	177.9	150.9	127.7	106.1	70.6
	61L4A / 62L4A*	304.6	239.5	205.7	173.9	147.0	121.9	81.7
95°F AMBIENT	27L4A	124.8	98.3	84.6	71.8	60.7	50.5	33.6
	30L4A	144.6	113.7	97.6	82.6	69.8	57.8	38.8
	44L4A / 46L4A*	197.2	156.2	135.0	115.1	98.3	82.5	57.2
	54L4A / 56L4A*	249.7	196.6	169.2	143.6	121.5	100.9	67.2
	61L4A / 62L4A*	289.2	227.4	195.3	165.1	139.6	115.7	77.6
100°F AMBIENT	27L4A	119.2	93.8	80.7	68.5	58.0	48.1	23.5
	30L4A	137.7	108.2	93.0	78.6	66.5	55.1	28.5
	44L4A / 46L4A*	187.3	148.4	128.3	109.4	93.4	78.4	39.5
	54L4A / 56L4A*	238.0	187.4	161.4	136.9	115.8	96.2	47.0
	61L4A / 62L4A*	275.4	216.5	185.9	157.2	132.9	110.1	57.0
110°F AMBIENT	27L4A	101.8	80.2	69.0	58.5	49.5	41.2	27.4
	30L4A	117.2	92.1	79.2	66.9	56.5	46.9	31.4
	44L4A / 46L4A*	161.0	127.5	110.2	94.0	80.2	67.4	46.7
	54L4A / 56L4A*	204.8	161.2	138.8	117.8	99.6	82.8	55.1
	61L4A / 62L4A*	235.7	185.3	159.2	134.6	113.8	94.3	63.3

*Dual compressor unit capacity is shown as combined total capacity of both systems.

WV-Series

Electrical Specifications - Single and Parallel Compressor Models

MODEL NUMBER WVC/ WVL/ WVS	COMP. MODEL	230V/3/60 Hz			TOTAL UNIT AMPS †	MCA †	460V/3/60 Hz			TOTAL UNIT AMPS †	MCA †	575V/3/60 Hz			TOTAL UNIT AMPS †	MCA †
		COMP.		COND FLA			COMP.		COND FLA			COMP.		COND FLA		
		RLA	LRA				RLA	LRA				RLA	LRA			

MEDIUM TEMPERATURE

20M4**	4DB-R20ME	64.7	374.0	12.8	78.5	95	32.4	187.0	6.4	39.8	48	28.2	135.0	4.3	33.5	40
25M4**	4DH-R22ME	73.7	428.0	12.8	87.5	106	36.9	214.0	6.4	44.3	54	30.8	172.0	4.3	36.1	43
30M4**	4DJ-R28ME	94.6	470.0	12.8	108.4	133	47.3	235.0	6.4	54.7	67	39.6	200.0	4.3	44.9	54
35M4**	6DH-R35ME	112.3	565.0	19.2	132.5	161	56.2	283.0	9.6	66.8	81	36.5	230.0	6.5	44.0	53
40M4**	6DJ-R40ME	128.2	594.0	19.2	148.4	181	64.1	297.0	9.6	74.7	91	46.2	245.0	6.5	53.7	65
24M4**	(2) 3DF-R15ME	86.4	550.0	12.8	100.2	111	42.4	276.0	6.4	49.8	56	-	-	-	-	-
31M4**	(2) 3DS-R17ME	107.0	550.0	19.2	127.2	141	52.0	276.0	9.6	62.6	70	42.4	220.0	6.5	49.9	55
41M4**	(2) 4DB-R20ME	129.4	748.0	19.2	149.6	166	64.8	374.0	9.6	75.4	84	56.4	270.0	6.5	63.9	70
51M4**	(2) 4DH-R22ME	147.4	856.0	25.6	174.0	193	73.8	428.0	12.8	87.6	97	61.6	344.0	8.6	71.2	78
61M4**	(2) 4DJ-R28ME	189.2	940.0	25.6	215.8	240	94.6	470.0	12.8	108.4	121	79.2	400.0	8.6	88.8	98
71M4**	(2) 6DH-R35ME	224.6	1,130.0	38.4	264.0	293	112.4	566.0	19.2	132.6	147	73.0	460.0	12.9	86.9	96
81M4**	(2) 6DJ-R40ME	256.4	1,188.0	38.4	295.8	328	128.2	594.0	19.2	148.4	165	92.4	490.0	12.9	106.3	114

LOW TEMPERATURE

27L4**	6DH-F93KE	72.4	450.0	12.8	86.2	105	36.2	225.0	6.4	43.6	53	29.2	172.0	4.3	34.5	41
30L4**	6DJ-F11ME	85.9	470.0	12.8	99.7	122	42.9	235.0	6.4	50.3	62	35.5	200.0	4.3	40.8	49
44L4**	(2) 4DJ-F76KE	115.4	748.0	19.2	135.6	151	57.6	374.0	9.6	68.2	76	52.2	270.0	6.5	59.7	66
54L4**	(2) 6DH-F93KE	144.8	900.0	19.2	165.0	184	72.4	450.0	9.6	83.0	93	58.4	344.0	6.5	65.9	73
61L4**	(2) 6DJ-F11ME	171.8	940.0	19.2	192.0	214	85.8	470.0	9.6	96.4	108	71.0	400.0	6.5	78.5	87

COND FLA = Condenser motors full load amps.

* Each asterisk represents a variable character based upon refrigerant and voltage ordered. See page 3 for nomenclature.

† Minimum Circuit Ampacity— Total for the condensing unit and does not include evaporator electrical loads.

Air Cooled Condensing Units 20 to 80 HP

Physical Data - Single and Parallel Compressor Models

MODEL NUMBER WVC/ WVL/ WVS	COMP. MODEL	CFH	QTY. COND. FANS	APPROXIMATE DIMENSIONS (in)			FAN CONFIG.	REC. CAP @ 90%	CONNECTION		APPROX. WEIGHT LBS.
				L	W	A			LIQUID ODS#	SUCTION ODS#	

MEDIUM TEMPERATURE

20M4**	4DB-R20ME	2,380	2	150-3/4	45-3/4	41-1/2	B	94	7/8	2-1/8	1,925
25M4**	4DH-R22ME	3,020	2	150-3/4	45-3/4	41-1/2	B	128	7/8	2-1/8	2,000
30M4**	4DJ-R28ME	3,603	2	150-3/4	45-3/4	41-1/2	B	162	1-1/8	2-1/8	2,140
35M4**	6DH-R35ME	4,530	3	198-3/4	45-3/4	41-1/2	C	195	1-1/8	2-1/8	2,385
40M4**	6DJ-R40ME	5,404	3	198-3/4	45-3/4	41-1/2	C	262	1-1/8	2-1/8	2,525
24M4**	(2) 3DF-R15ME	3826^	2	185	45-3/4	75-3/4	B [‡]	162	1-1/8	2-1/8	2,750
31M4**	(2) 3DS-R17ME	4254^	3	233	45-3/4	75-3/4	C [‡]	195	1-1/8	2-1/8	3,050
41M4**	(2) 4DB-R20ME	4760^	3	233	45-3/4	75-3/4	C [‡]	262	1-1/8	2-1/8	3,200
51M4**	(2) 4DH-R22ME	6040^	4	150-3/4	90-3/4	41-1/2	D	262	1-1/8	2-5/8	3,500
61M4**	(2) 4DJ-R28ME	7206^	4	150-3/4	90-3/4	41-1/2	D	262	1-3/8	2-5/8	3,710
71M4**	(2) 6DH-R35ME	9060^	6	198-3/4	90-3/4	41-1/2	E	370	1-3/8	3-1/8	4,340
81M4**	(2) 6DJ-R40ME	10808^	6	198-3/4	90-3/4	41-1/2	E	445	1-5/8	3-1/8	4,750

LOW TEMPERATURE

27L4**	6DH-F93KE	4,530	2	150-3/4	45-3/4	41-1/2	B	128	7/8	2-1/8	2,000
30L4**	6DJ-F11ME	5,404	2	150-3/4	45-3/4	41-1/2	B	145	7/8	2-1/8	2,065
44L4**	(2) 4DJ-F76KE	7206^	3	233	45-3/4	75-3/4	C [‡]	195	1-1/8	3-1/8	2,800
54L4**	(2) 6DH-F93KE	9060^	3	233	45-3/4	75-3/4	C [‡]	262	1-1/8	3-1/8	3,280
61L4**	(2) 6DJ-F11ME	10808^	3	233	45-3/4	75-3/4	C [‡]	262	1-1/8	3-1/8	3,580

* Each asterisk represents a variable character based upon refrigerant and voltage ordered. See page 3 for nomenclature.

^ Combined CFH when two compressors are piped in parallel.

One item per condensing unit.

‡ Long version.

WV-Series

Electrical Specifications - Dual Compressor Models

MODEL NUMBER WVC/ WVL/ WVS	COMP. MODEL	230V/3/60 Hz			TOTAL UNIT AMPS †	MCA †	460V/3/60 Hz			TOTAL UNIT AMPS †	MCA †	575V/3/60 Hz			TOTAL UNIT AMPS †	MCA †
		COMP.		COND FLA			COMP.		COND FLA			COMP.		COND FLA		
		RLA	LRA				RLA	LRA				RLA	LRA			

MEDIUM TEMPERATURE

18M4**	(2) 3DA-R10ME	73.6	430.0	12.8	87.4	97	35.8	212.0	6.4	43.2	48	29.4	168.0	4.3	34.7	38
23M4**	(2) 3DB-R12ME	78.2	430.0	12.8	92.0	102	35.8	212.0	6.4	43.2	48	29.6	168.0	4.3	34.9	38
26M4**	(2) 3DF-R15ME	86.4	550.0	12.8	100.2	111	42.4	276.0	6.4	49.8	56	-	-	-	-	-
32M4**	(2) 3DS-R17ME	107.0	550.0	19.2	127.2	141	52.0	276.0	9.6	62.6	70	42.4	220.0	6.5	49.9	55
42M4**	(2) 4DB-R20ME	129.4	748.0	19.2	149.6	166	64.8	374.0	9.6	75.4	84	56.4	270.0	6.5	63.9	70
52M4**	(2) 4DH-R22ME	147.4	856.0	25.6	174.0	193	73.8	428.0	12.8	87.6	97	61.6	344.0	8.6	71.2	78
62M4**	(2) 4DJ-R28ME	189.2	940.0	25.6	215.8	240	94.6	470.0	12.8	108.4	121	79.2	400.0	8.6	88.8	98
72M4**	(2) 6DH-R35ME	224.6	1,130.0	38.4	264.0	293	112.4	566.0	19.2	132.6	147	73.0	460.0	12.9	86.9	96
82M4**	(2) 6DJ-R40ME	256.4	1,188.0	38.4	295.8	328	128.2	594.0	19.2	148.4	165	92.4	490.0	12.9	106.3	114

LOW TEMPERATURE

46L4**	(2) 4DJ-F76KE	115.4	748.0	19.2	135.6	151	57.6	374.0	9.6	68.2	76	52.2	270.0	6.5	59.7	66
56L4**	(2) 6DH-F93KE	144.8	900.0	19.2	165.0	184	72.4	450.0	9.6	83.0	93	58.4	344.0	6.5	65.9	73
62L4**	(2) 6DJ-F11ME	171.8	940.0	19.2	192.0	214	85.8	470.0	9.6	96.4	108	71.0	400.0	6.5	78.5	87

Physical Data - Dual Compressor Models (two independent systems[^])

MODEL NUMBER WVC/ WVL/ WVS	COMP. MODEL	CFH	QTY COND. FANS	APPROXIMATE DIMENSIONS (in)			FAN CONFIG	REC. CAP @ 90%	CONNECTION		APPROX. WEIGHT LBS.
				L	W	A			LIQUID ODS#	SUCTION ODS#	

MEDIUM TEMPERATURE

18M4**	(2) 3DA-R10ME	1,375	2	185	45-3/4	75-3/4	B [†]	(2) 55	(2) 7/8	(2) 1-3/8	2,450
23M4**	(2) 3DB-R12ME	1,620	2	185	45-3/4	75-3/4	B [†]	(2) 55	(2) 7/8	(2) 1-5/8	2,575
26M4**	(2) 3DF-R15ME	1,915	2	185	45-3/4	75-3/4	B [†]	(2) 55	(2) 7/8	(2) 1-5/8	2,650
32M4**	(2) 3DS-R17ME	2,120	3	233	45-3/4	75-3/4	C [‡]	(2) 94	(2) 7/8	(2) 1-5/8	3,050
42M4**	(2) 4DB-R20ME	2,380	3	233	45-3/4	75-3/4	C [‡]	(2) 94	(2) 7/8	(2) 2-1/8	3,200
52M4**	(2) 4DH-R22ME	3,020	4	150-3/4	90-3/4	41-1/2	D	(2) 128	(2) 7/8	(2) 2-1/8	3,500
62M4**	(2) 4DJ-R28ME	3,603	4	150-3/4	90-3/4	41-1/2	D	(2) 162	(2) 1-1/8	(2) 2-1/8	3,710
72M4**	(2) 6DH-R35ME	4,530	6	198-3/4	90-3/4	41-1/2	E	(2) 195	(2) 1-1/8	(2) 2-1/8	4,340
82M4**	(2) 6DJ-R40ME	5,404	6	198-3/4	90-3/4	41-1/2	E	(2) 262	(2) 1-1/8	(2) 2-1/8	4,750

LOW TEMPERATURE

46L4**	(2) 4DJ-F76KE	3,603	3	233	45-3/4	75-3/4	C [‡]	(2) 94	(2) 7/8	(2) 2-1/8	2,800
56L4**	(2) 6DH-F93KE	4,530	3	233	45-3/4	75-3/4	C [‡]	(2) 128	(2) 7/8	(2) 2-1/8	3,280
62L4**	(2) 6DJ-F11KE	5,404	3	233	45-3/4	75-3/4	C [‡]	(2) 128	(2) 7/8	(2) 2-1/8	3,580

COND FLA = Condenser motors full load amps.

* Each asterisk represents a variable character based upon refrigerant and voltage ordered. See page 4 for nomenclature.

† Minimum Circuit Ampacity — Total for the condensing unit and does not include evaporator electrical loads.

One item per compressor system.

* Long version.

^ Data shown for each compressor system.

Air Cooled Condensing Units 20 to 80 HP

Specifications - All Models

Department of Energy Annual Walk-In Energy Factor (AWEF) Ratings		
Base Model Number	AWEF	
	Outdoor Rated	Indoor Rated
Medium Temperature Models		
WV**20M4**	9.33	—
WV**25M4**	9.54	—

* Each asterisk represents a variable character based upon model, voltage, and vintage ordered. See page 3 for nomenclature.

Larger HP V-Series models are not intended for use in walk-in coolers less than 3,000 sq. feet thus are outside the scope of this DOE regulation.

Dept. of Energy AWEF ratings for low temperature condensing models will be implemented in 2020.

Dimensional Drawings

FAN CONFIGURATION "A"

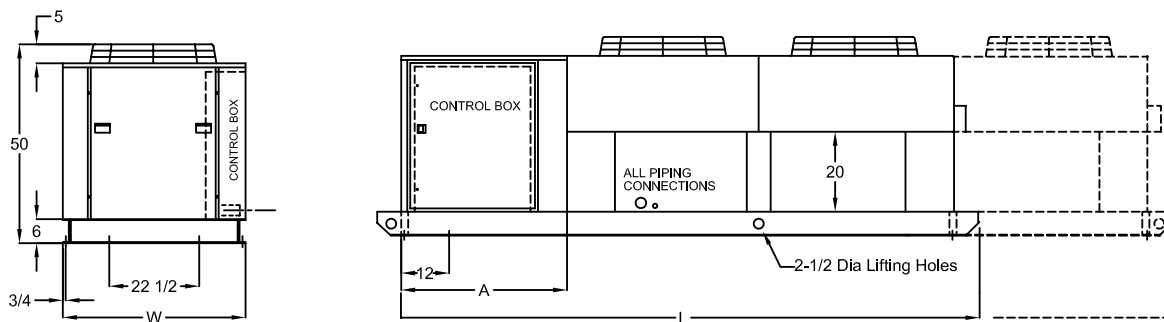

FAN CONFIGURATION "B"

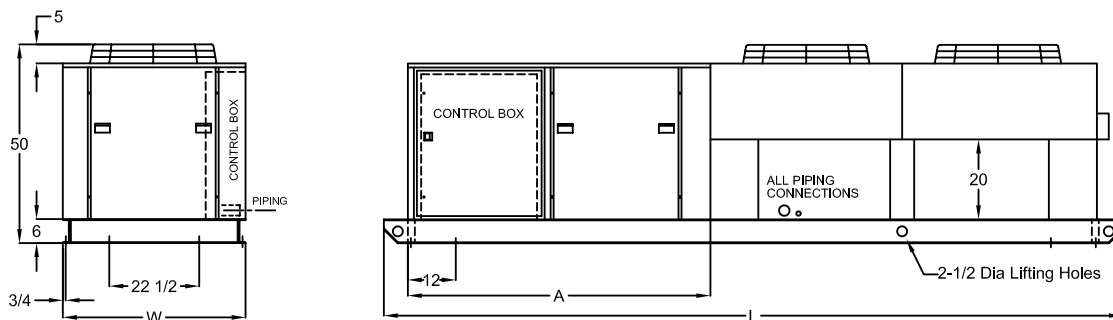

* All dimensions are in inches.

WV-Series

Dimensional Drawings

FAN CONFIGURATION "C"

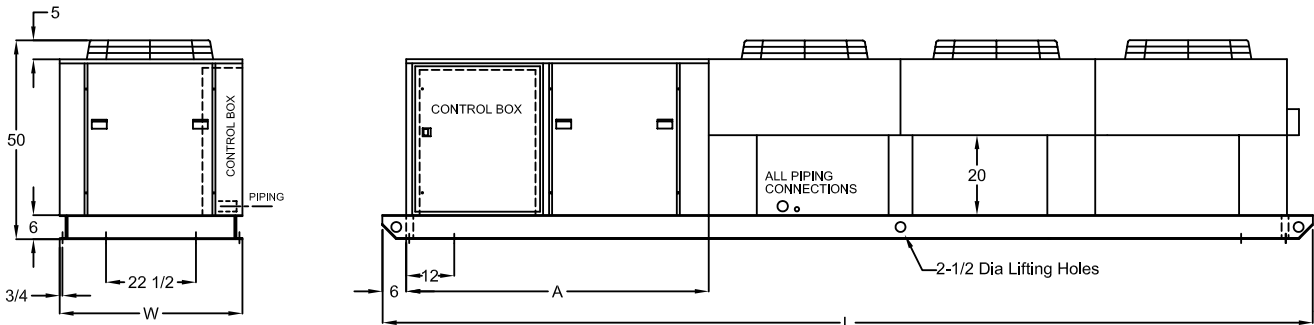

FAN CONFIGURATION "D"

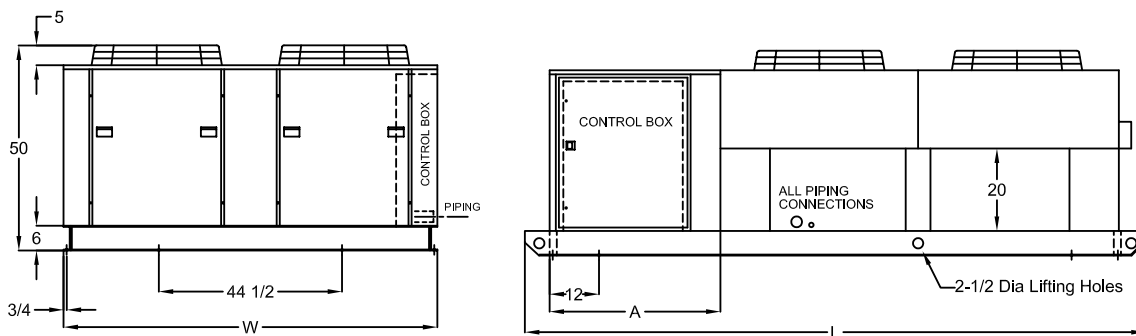

FAN CONFIGURATION "E"

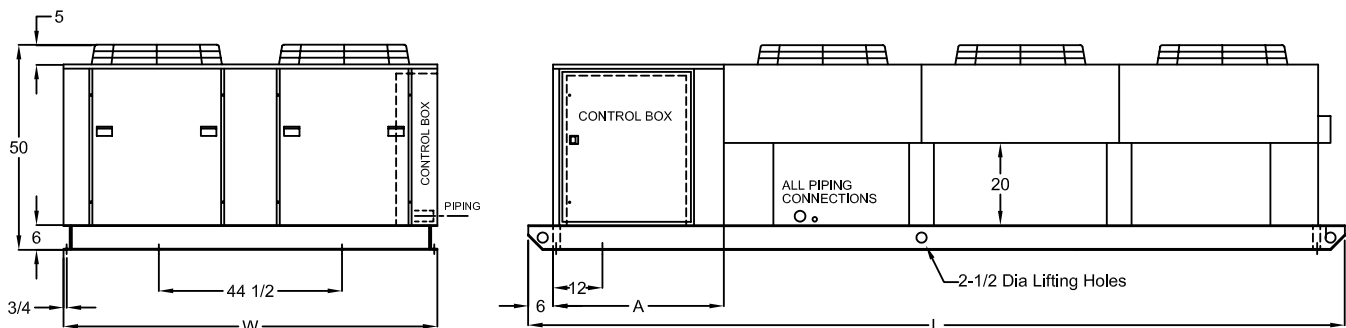

* All dimensions are in inches.

Due to continuing product development, specifications are subject to change without notice.

