



Wedge-Temp  
**REACH-IN  
UNIT COOLER**



Air Defrost for reach-ins, back-bars, beverage cases, salad cases and other applications above 34° F.

Heavy-gauge, all Aluminum housing; front panel and drain-pan assembly hinged to provide easy access. These air defrost units are available with our specially formulated epoxy coil coating.



# REACH-IN UNIT COOLER

## Specifications

MODEL	BTU/HR. RATING		CFM	FAN AND MOTOR			
	10° T.D.	15° T.D.		Fan	Motor	115V Motor Amps <sup>3</sup>	RPM
WE 17-12	1200	1440	220	8"	9W	0.6	1550
WE 17-15	1500	1800	260	8"	9W	0.6	1550
WE 17-18	1800	2160	290	8"	9W	0.6	1550
WE 17-25	2500	3000	450	10"	9W	0.6	1550
WE 17-35	3500	4200	520	10"	16W	1.1	1550
WE 17-45	4500	5400	810	12"	1/20	1.7	1550
WE 18-55	5500	6600	780	12"	1/20	1.7	1550

- NOTES: 1. Standard motors are life lubricated, 115 volts.  
 2. Knock outs are provided on both sides.  
 3. 230V motor amps equals 115V amps x 0.5

## Dimensions

MODEL	A	B	C	D	F	H	W	Liquid Conn.	Suction Conn.	Weight (lbs.)
WE 17-12	12-3/4"	13-5/8"	15-13/16"	11-7/16"	1-1/4"	8-5/16"	15-1/4"	1/2" FN	1/2" OD	16
WE 17-15	12-3/4"	13-5/8"	15-13/16"	11-7/16"	1-1/4"	8-5/16"	15-1/4"	1/2" FN	1/2" OD	19
WE 17-18	15-3/4"	13-5/8"	15-13/16"	14-1/2"	1-1/4"	8-5/16"	17-3/4"	1/2" FN	1/2" OD	22
WE 17-25	18-3/4"	14-5/8"	16-13/16"	17-1/2"	1-1/4"	8-5/16"	19-7/8"	1/2" FN	1/2" OD	29
WE 17-35	21-3/4"	15-5/8"	17-7/8"	20-1/2"	1-1/4"	9-1/2"	22-7/8"	1/2" FN	1/2" OD	36
WE 17-45	24-3/4"	15-5/8"	20-1/2"	23-5/8"	1-7/8"	9-5/8"	26-3/4"	1/2" FN	1/2" OD	57
WE 18-55	24-3/4"	15-5/8"	20-1/2"	23-5/8"	1-7/8"	9-5/8"	26-3/4"	1/2" FN	1/2" OD	65

\* All dimensions are in inches.

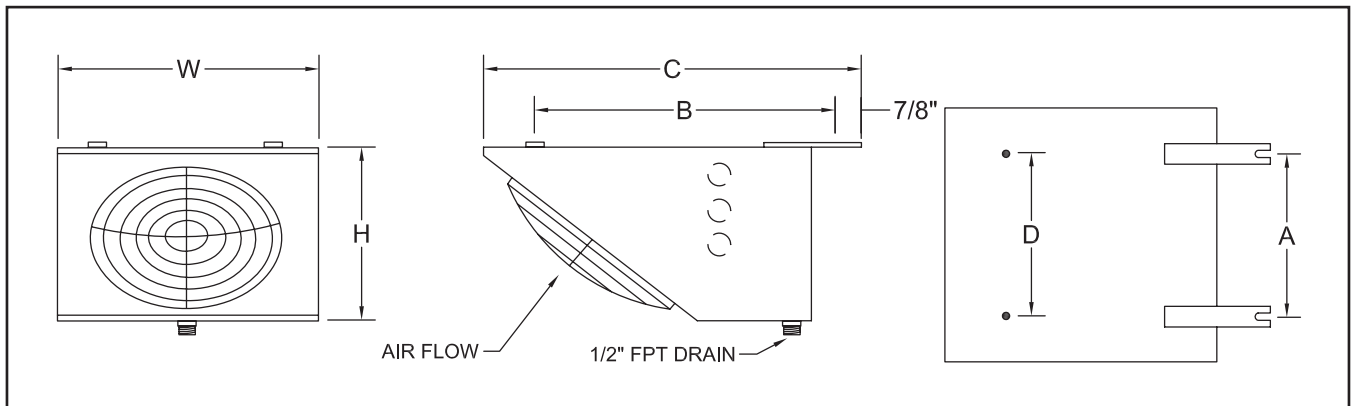

Due to continuing product development, specifications are subject to change without notice.