

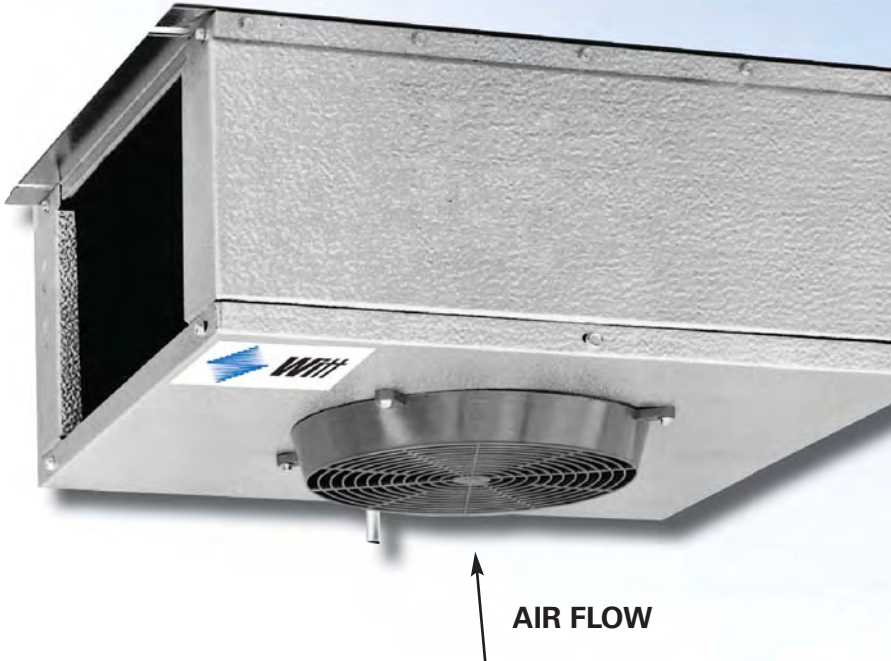

Twin-Temp
**Reach-In
Unit Cooler**



The Twin-Temp 2-way Unit Cooler is ideal for reach-in and walk-in applications above 34°F where efficient two-way air discharge is required.

These units are designed for easy installation, low maintenance and long life, especially when our uniquely formulated epoxy coating is applied to the coil.



Reach-In Unit Cooler

Specifications

MODEL NUMBER	FIG.	CAPACITY (BTU/HR)		FAN DATA		MOTOR DATA		DIMENSIONS (In)						CONNECTION SIZE (In)			SHIP WT. (lbs)
		10°TD	15°TD	CFM	DIAM. (In)	HP	AMPS @ 115V	A	B	C	D	E	F	SUCTION	INLET	DRAIN	
TW 17-9	1	900	1,350	150	8	9 W	.6	18-1/2	16-1/2	7-5/8	5-7/8	12-1/2	19	1/2 MF	1/2 FN	1/2 OD	17
TW 17-12	1	1,200	1,800	190	88	9 W	.6	18-1/2	16-1/2	7-5/8	5-7/8	12-1/2	19	1/2 MF	1/2 FN	1/2 OD	19
TW 17-18	1	1,800	2,700	260	10	9 W	.6	18-1/2	16-1/2	9-1/8	7-3/8	12-1/2	19	1/2 MF	1/2 FN	1/2 OD	23
TW 17-25	1	2,500	3,750	350	10	9 W	.6	20-1/2	18-1/2	9-5/8	7-3/8	15	21	1/2 MF	1/2 FN	1/2 OD	26
TW 17-35	1	3,500	5,250	440	12	9 W	.6	20-1/2	18-1/2	11-1/4	9	15	21	1/2 MF	1/2 FN	1/2 OD	28
TW 17-45	1	4,500	6,750	530	12	1/20	1.7	30-1/2	21-1/4	10	7-3/4	17	32	5/8 OD	1/2 OD	1/2 FPT	44
TW 17-55	1	5,500	8,250	650	12	1/20	1.7	30-1/2	21-1/4	12	9-3/4	17	32	5/8 OD	1/2 OD	1/2 FPT	50
TW 18-65	1	6,500	9,750	820	12	1/20	1.7	30-1/2	21-1/4	12	9-3/4	17	32	5/8 OD	1/2 OD	1/2 FPT	55
TW 17-75	2	7,500	11,250	960	16	1/12	3.5	35-1/4	36-1/4	11	7-3/4	31	36-1/2	5/8 OD	1/2 OD	1/2 FPT	109
TW 18-85	2	8,500	12,750	1100	16	1/12	3.5	35-1/4	36-1/4	11	7-3/4	31	36-1/2	5/8 OD	1/2 OD	1/2 FPT	115
TW 17-105	2	10,500	15,750	1350	16	1/12	3.5	35-1/4	36-1/4	13	9-3/4	31	36-1/2	7/8 OD	5/8 OD	1/2 FPT	121
TW 18-120	2	12,000	18,000	1540	16	1/12	3.5	35-1/4	36-1/4	13	9-3/4	31	36-1/2	7/8 OD	5/8 OD	1/2 FPT	128

* All dimensions are in inches.

- (1) Externally equilized expansion valves must be used on models TW 17-105 and TW 17-120.
 (2) 230V motor amps = 115V amps x 0.5

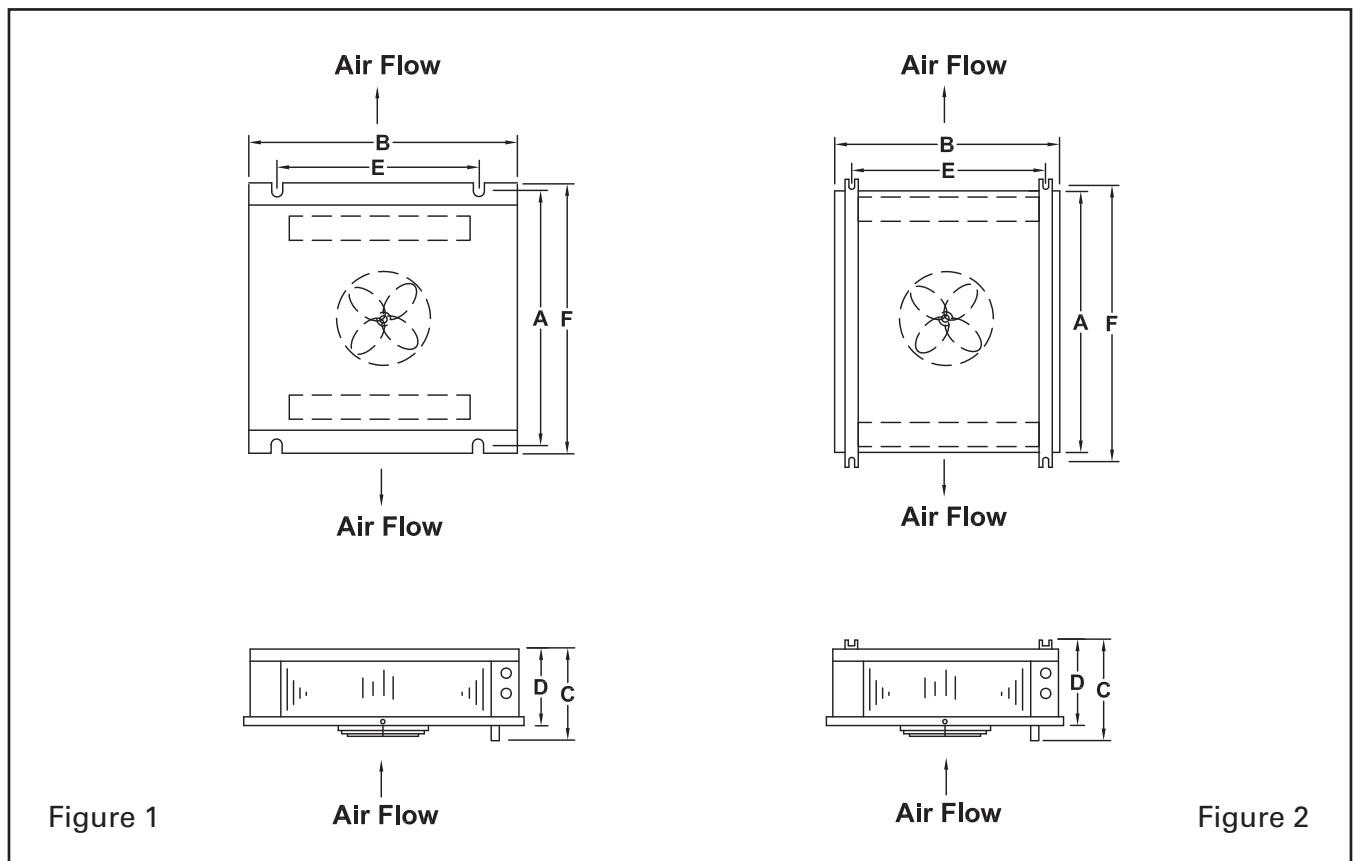

Due to continuing product development, specifications are subject to change without notice.



Witt

201 Thomas French Drive, Scottsboro, AL 35769 PHONE (256) 259-7400 FAX (256) 259-7478 witt.htpgusa.com