

All-Temp

LOW PROFILE UNIT COOLER

Small to Medium Walk-Ins
Coolers and Freezer Applications

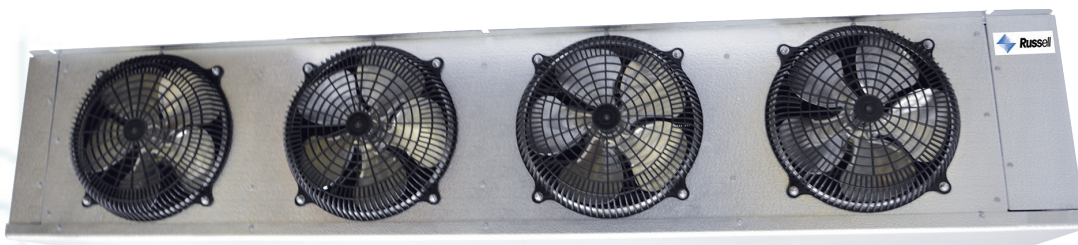

Air Defrost
3,900 to 39,000 BTUH

Electric Defrost
3,600 to 28,000 BTUH

Hot Gas Defrost
3,600 to 28,000 BTUH

ALL-TEMP

Features

The Russell All-Temps are the original low profile unit coolers that established the industry standard as being the all-purpose design for walk-in coolers, freezers and other applications. The units feature an air draw-through design, easy access for serviceability, and are available in air, electric and hot gas defrost models.

SIZES

There are a wide array of sizes available with capacities ranging from 3,600 to 39,000 BTUH at a 10° TD spanning from 740 to 4,980 cfm. One through six fan models are available.

HOUSING

The embossed Aluminum casing is lightweight yet durable. Each fan section is baffled to prevent short cycling of the air. The unit is designed to mount flush to the ceiling and meets all NSF requirements. The top pan is slotted for simple installation. Drain fittings are installed in the bottom of the drain pan for easy field connection and the drain fitting can be quickly replaced without replacing the entire drain pan. The end panels can now be slid out from the front of the unit for easy serviceability from the front or end of the unit.

COIL

Copper hairpins are staggered and mechanically expanded into corrugated Aluminum fins and tube sheets to achieve maximum heat transfer. Die formed fin collars provide even fin spacing and are available in 4, 6 and 8 fins per inch. Sweat connections are standard on all models.

MOTORS

High efficiency single-speed and dual-speed Electronically Commutated (EC) motors are available in 115V and 208/230V. The dual-speed EC motors are compliant with California Title 24 regulations. Single-speed PSC motors are available in 115V, 208/230V and 460V. All motors include thermal overload protection.

CONFIGURATIONS

Units are available as Configurable (no mounted accessories) or Pre-assembled with the most requested options installed for your convenience.

Pre-assembly Code¹:

- Blank = Configurable
- T = Factory mounted TXV
- L = Factory mounted TXV, Liq. Line Solenoid (LLS) and Mechanical T-Stat
- M = Master Configuration with mounted TXV, T-Stat, LLS and copper Tee

FANS

Heavy duty 12" Aluminum fans are balanced to provide vibration-free operation. Our low throw black plastic fan guards provide an optimal air pattern. The optional epoxy resin high throw fan guard moves air up to 25 feet.

ELECTRICAL

Available in 115V, 208/230V and 460V (see pages 4 and 5). All components are factory wired to convenient screw-type terminal strips. A large compartment is supplied internal to the unit for all electrical components and is easily accessible by opening the slide out end panel. All models are UL and cUL listed and are available in 60 or 50 Hz.

AIR DEFROST

Air Defrost models (prefix "AA") are designed for use in coolers of 35°F and warmer. Complete air defrost systems for off-cycle or timed air defrost are available.

ELECTRIC DEFROST

Electric Defrost models (prefix "AE") are designed for use in coolers and freezers between 34°F to -20°F. Internal coil heaters provide rapid and efficient defrost. A lower heater is installed close to the drain pan for fast, reliable drainage. A defrost termination fan delay thermostat (DTFD) terminates the defrost cycle when the temperature is satisfied. The fan delay allows the warm coil to cool after a defrost cycle prior to the fans turning on. A heater safety thermostat is installed to prevent heaters from overheating above 75°F. Complete electric defrost refrigeration systems are available from Russell.

HOT GAS DEFROST

There are two types of Hot Gas Defrost models available: Hot Gas 3 Pipe (prefix "AH") and Hot Gas Reverse Cycle 2 Pipe (prefix "AG"). Hot Gas Defrost models are designed for use in coolers and freezers between 30°F to -20°F. All models include a fixed DTFD factory wired and a hot gas drain pan circuit to defrost the drain pan. On all Hot Gas models, the drain fitting is located on the left-hand rear of the unit when facing the fan guards. Complete Hot gas defrost refrigeration systems are available from Russell.

Optional Features

- Coated Aluminum fins (Russproof, ElectroFin², or Heresite²) or Copper fins
- Coated housing (same options as above)
- Epoxy resin high throw guards for up to 25 ft.
- Adjustable termination/ fan delay control*
- Insulated drain pan*

* These options require the units to be built as Revision B models.

1. Codes T, L and M are intended for units in finished goods inventory only. Call out separate options for units built with normal lead times.
2. ElectroFin and Heresite coatings are not NSF approved. NSF approval label will be removed from unit if ordered with these coatings.

LOW PROFILE UNIT COOLER

Electronically commutated motors bring energy efficiency to the refrigeration Unit Cooler market. Features of the EC motors we offer include:

- Integrated control with sealed construction
- Locked rotor with overload fold-back protection
- Durable ball bearing construction for long commercial life
- Unique hall sensor design prevents synching or resonance
- Threaded shaft uses hubless fan blade
- Available in single or dual speed configurations

Energy Savings by Switching from PSC to Efficient EC Motor

Chart is based on Energy Cost of \$0.10 per kWh.

Motor Change	Std Motor Power Watts/Mtr	Change to Motor Power Watts/Mtr	Reduced Power Watts/Mtr	Run Time Hrs/Day	Motor Energy Savings kWh/Yr	Motor Energy Savings \$/Yr	Reduced Box Load MBTU/Yr	Cond. Unit Energy Savings \$/Yr	Yearly Saving \$ Per MTR	Pay back in Yrs
PSC to EC	85	47	38	22	305	31	1041	20	51	2.0

Subtract 6% from total savings for medium temperature air defrost units that run 24 hours per day.

PSC = 1/20 HP PSC motor

EC = 50 Watt Electronically Commutated motor

Yearly Savings by Switching from PSC to EC Motor

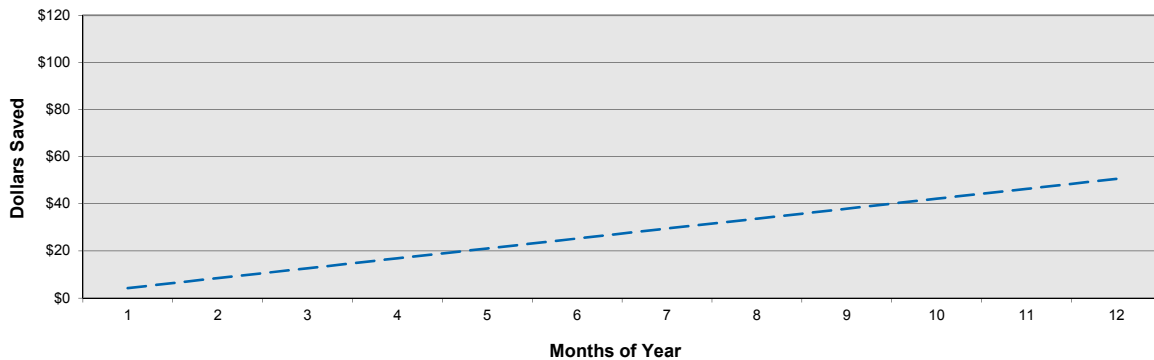

MODEL NUMBER NOMENCLATURE

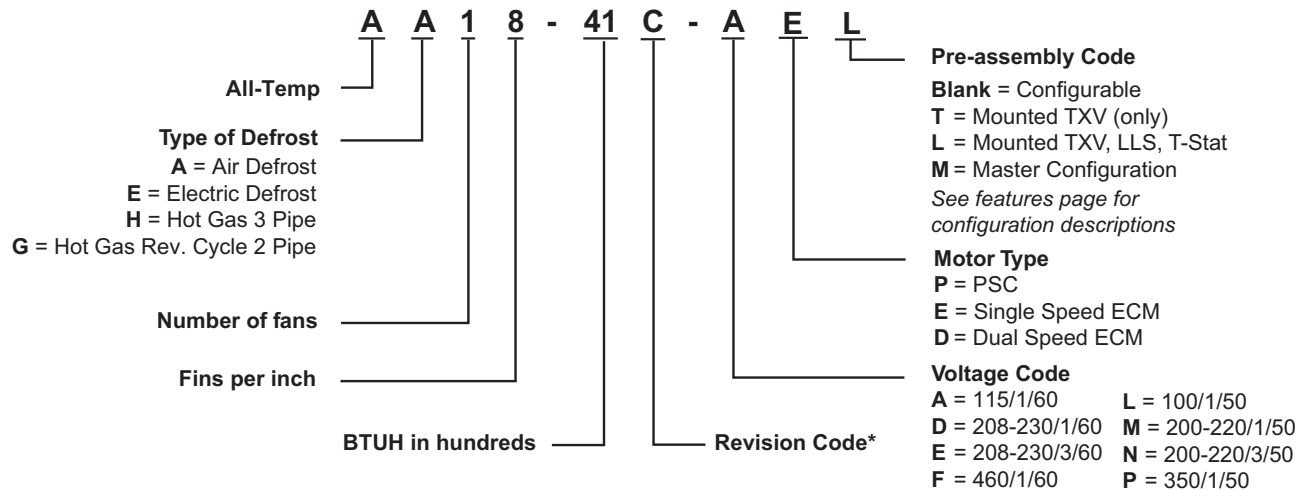

* Hot Gas Defrost models (AG, AH) are not available in Revision Code "C" configuration and must be designated as Revision Code "B".

ALL-TEMP

Performance and Electrical Data - Air Defrost Models

	Model Number	BTUH* Capacity @ 25°F S.T.		CFM	Total Fan Motor AMPS - 1 Phase				
		10°TD	12°TD		Single and Dual [^] Speed EC Motors [†]		Single Speed PSC Motors		
					115V	208-230V	115V	208-230V	460V
8 FPI	AA18-41C	4,100	4,900	800	0.8	0.5	1.0	0.5	0.4
	AA18-53C	5,300	6,400	770	0.8	0.5	1.0	0.5	0.4
	AA18-66C	6,600	7,900	740	0.8	0.5	1.0	0.5	0.4
	AA28-76C	7,600	9,100	1,460	1.6	1.0	2.0	1.0	0.8
	AA28-97C	9,700	11,600	1,420	1.6	1.0	2.0	1.0	0.8
	AA28-106C	10,600	12,700	1,540	1.6	1.0	2.0	1.0	0.8
	AA28-122C	12,200	14,600	1,380	1.6	1.0	2.0	1.0	0.8
	AA28-134C	13,400	16,100	1,480	1.6	1.0	2.0	1.0	0.8
	AA38-160C	16,000	19,200	2,310	2.4	1.5	3.0	1.5	0.8
	AA38-195C	19,500	23,400	2,220	2.4	1.5	3.0	1.5	1.2
	AA48-212C	21,200	25,400	3,080	3.2	2.0	4.0	2.0	1.6
	AA48-264C	26,400	31,700	2,960	3.2	2.0	4.0	2.0	1.6
	AA58-275C	27,500	33,000	3,850	4.0	2.5	5.0	2.5	2.0
	AA68-318C	31,800	38,200	4,620	4.8	3.0	6.0	3.0	2.4
AA68-390C	39,000	46,800	4,440	4.8	3.0	6.0	3.0	2.4	
6 FPI	AA16-39C	3,900	4,700	830	0.8	0.5	1.0	0.5	0.4
	AA16-48C	4,800	5,800	800	0.8	0.5	1.0	0.5	0.4
	AA16-58C	5,800	7,000	780	0.8	0.5	1.0	0.5	0.4
	AA26-70C	7,000	8,400	1,540	1.6	1.0	2.0	1.0	0.8
	AA26-87C	8,700	10,400	1,500	1.6	1.0	2.0	1.0	0.8
	AA26-115C	11,500	13,800	1,560	1.6	1.0	2.0	1.0	0.8
	AA36-145C	14,500	17,400	2,400	2.4	1.5	3.0	1.5	1.2
	AA36-170C	17,000	20,400	2,340	2.4	1.5	3.0	1.5	1.2
	AA46-192C	19,200	23,000	3,200	3.2	2.0	4.0	2.0	1.6
	AA46-230C	23,000	27,600	3,120	3.2	2.0	4.0	2.0	1.6
AA56-245C	24,500	29,400	4,000	4.0	2.5	5.0	2.5	2.0	
AA66-295C	29,500	35,400	4,800	4.8	3.0	6.0	3.0	2.4	
AA66-345C	34,500	41,400	4,680	4.8	3.0	6.0	3.0	2.4	
4 FPI	AA14-42C	4,200	5,000	830	0.8	0.5	1.0	0.5	0.4
	AA24-84C	8,400	10,100	1,660	1.6	1.0	2.0	1.0	0.8
	AA24-105C	10,500	12,600	1,620	1.6	1.0	2.0	1.0	0.8
	AA34-130C	13,000	15,600	2,490	2.4	1.5	3.0	1.5	1.2
	AA44-170C	17,000	20,400	3,320	3.2	2.0	4.0	2.0	1.6
	AA54-215C	21,500	25,800	4,150	4.0	2.5	5.0	2.5	2.0
	AA64-255C	25,500	30,600	4,980	4.8	3.0	6.0	3.0	2.4

Use EC motors for 50 Hz operation.

* Standard rating based on R404A refrigerant with 100°F liquid temperature. Consult factory for other operating conditions.

† These Electronically Commutated (EC) Motors are not available in 460V or 575V.

[^] Dual-speed EC motors are compliant with California Title 24 regulations.

End panels slide out for easy serviceability from the front or ends of the unit

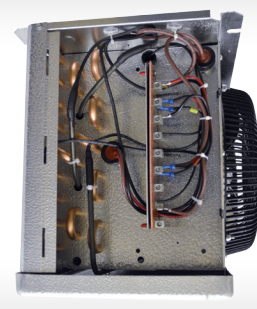

LOW PROFILE UNIT COOLER

Performance and Electrical Data - Electric Defrost Models

	Model Number	BTUH* Capacity @ 10° T.D. Suction Temperature				CFM	Motor Amps ¹			Heater Amps ²			Heater Watts
		-30°F	-20°F	-10°F	+20°		Single and Dual [^] Speed EC Motorst	Single Speed PSC Motors		230V		460V	
								230V	230V	460V	1 PH	3 PH	
6 FPI	AE16-36C	3,400	3,600	3,700	3,900	830	0.5	0.5	0.4	4.4	3.8	2.2	1,000
	AE16-41C	3,900	4,100	4,300	4,800	800	0.5	0.5	0.4	4.4	3.8	2.2	1,000
	AE16-46C	4,400	4,600	4,800	5,800	780	0.5	0.5	0.4	4.4	3.8	2.2	1,000
	AE26-60C	5,700	6,000	6,200	7,000	1,540	1.0	1.0	0.8	7.0	6.0	3.5	1,600
	AE26-75C	7,100	7,500	7,800	8,700	1,500	1.0	1.0	0.8	7.0	6.0	3.5	1,600
	AE26-92C	8,700	9,200	9,600	11,500	1,560	1.0	1.0	1.2	8.7	7.5	4.4	2,000
	AE36-120C	11,400	12,000	12,500	14,500	2,400	1.5	1.5	1.2	13.0	11.3	6.4	3,000
	AE36-140C	13,300	14,000	14,600	17,000	2,340	1.5	1.5	1.2	13.0	11.3	6.4	3,000
	AE46-164C	15,000	16,400	17,100	19,200	3,200	2.0	2.0	1.6	17.4	15.1	8.7	4,000
	AE46-185C	17,600	18,500	19,200	23,000	3,120	2.0	2.0	1.6	17.4	15.1	8.7	4,000
4 FPI	AE56-210C	20,000	21,000	21,800	24,500	4,000	2.5	2.5	2.0	21.7	18.8	10.9	5,000
	AE66-245C	23,300	24,500	25,500	29,500	4,800	3.0	3.0	2.4	25.0	21.7	12.5	5,750
	AE66-280C	26,600	28,000	29,100	34,500	4,680	3.0	3.0	2.4	25.0	21.7	12.5	5,750
	AE14-37C	3,500	3,700	3,800	4,200	830	0.5	0.5	0.4	4.4	3.8	2.2	1,000
	AE24-72C	6,800	7,200	7,500	8,400	1,660	1.0	1.0	0.8	8.7	7.5	4.4	2,000
	AE24-85C	8,100	8,500	8,800	10,500	1,620	1.0	1.0	0.8	8.7	7.5	4.4	2,000
	AE34-105C	10,000	10,500	10,900	13,000	2,490	1.5	1.5	1.2	13.0	11.3	6.4	3,000
	AE44-140C	13,300	14,000	14,600	17,000	3,320	2.0	2.0	1.6	17.4	15.1	8.7	4,000
AE54-180C	17,100	18,000	18,700	21,500	4,150	2.5	2.5	2.0	21.7	18.8	10.9	5,000	
AE64-215C	20,400	21,500	22,400	25,500	4,980	3.0	3.0	2.0	25.0	21.7	12.5	5,750	

* Standard rating based on R404A refrigerant with 100°F liquid temperature. Consult factory for other operating conditions.

† These Electronically Commutated (EC) Motors are not available in 460V or 575V.

^ Dual-speed EC motors are compliant with California Title 24 regulations.

1. All fan motors are wired for single phase.

Use EC motors for 50 Hz operation.



Mounts flush to the ceiling to maximize headroom and space

UL certified for use with multiple refrigerants

Single fan through six fan models are available

ALL-TEMP

Performance and Electrical Data - Hot Gas Defrost Models

	Model Number		BTUH Capacity @ 10° T.D.				CFM	Fan Motor Amps ¹					Heat Exchange Field Installed
			Suction Temperature					Single and Dual [^] Speed EC Motor [†]		Single Speed PSC Motor [†]			
			-30°F	-20°F	-10°F	+20°		115V	230V	115V	230V	460V	
6 FPI	AG16-36B	AH16-36B	3,400	3,600	3,700	3,900	830	0.8	0.5	1.0	0.5	0.4	HX-25
	AG16-41B	AH16-41B	3,900	4,100	4,300	4,800	800	0.8	0.5	1.0	0.5	0.4	HX-25
	AG16-46B	AH16-46B	4,400	4,600	4,800	5,800	780	0.8	0.5	1.0	0.5	0.4	HX-25
	AG26-60B	AH26-60B	5,700	6,000	6,200	7,000	1,540	1.6	1.0	2.0	1.0	0.8	HX-25
	AG26-75B	AH26-75B	7,100	7,500	7,800	8,700	1,500	1.6	1.0	2.0	1.0	0.8	HX-50
	AG26-92B	AH26-92B	8,700	9,200	9,600	11,500	1,560	1.6	1.0	2.0	1.0	0.8	HX-50
	AG36-120B	AH36-120B	11,400	12,000	12,500	14,500	2,400	2.4	1.5	3.0	1.5	1.2	HX-50
	AG36-140B	AH36-140B	13,300	14,000	14,600	17,000	2,340	2.4	1.5	3.0	1.5	1.2	HX-75
	AG46-164B	AH46-164B	15,000	16,400	17,100	19,200	3,200	3.2	2.0	4.0	2.0	1.6	HX-75
	AG46-185B	AH46-185B	17,600	18,500	19,200	23,000	3,120	3.2	2.0	4.0	2.0	1.6	HX-75
4 FPI	AG56-210B	AH56-210B	20,000	21,000	21,800	24,500	4,000	4.0	2.5	5.0	2.5	2.0	HX-75
	AG66-245B	AH66-245B	23,300	24,500	25,500	29,500	4,800	4.8	3.0	6.0	3.0	2.4	HX-100
	AG66-280B	AH66-280B	26,600	28,000	29,100	34,500	4,680	4.8	3.0	6.0	3.0	2.4	HX-100
	AG14-37B	AH14-37B	3,500	3,700	3,800	4,200	830	0.8	0.5	1.0	0.5	0.4	HX-25
	AG24-72B	AH24-72B	6,800	7,200	7,500	8,400	1,660	1.6	1.0	2.0	1.0	0.8	HX-50
	AG24-85B	AH24-85B	8,100	8,500	8,800	10,500	1,620	1.6	1.0	2.0	1.0	0.8	HX-50
	AG34-105B	AH34-105B	10,000	10,500	10,900	13,000	2,490	2.4	1.5	3.0	1.5	1.2	HX-50
	AG44-140B	AH44-140B	13,300	14,000	14,600	17,000	3,320	3.2	2.0	4.0	2.0	1.6	HX-75
	AG54-180B	AH54-180B	17,100	18,000	18,700	21,500	4,150	4.0	2.5	5.0	2.5	2.0	HX-75
	AG64-215B	AH64-215B	20,400	21,500	22,400	25,500	4,980	4.8	3.0	6.0	3.0	2.4	HX-100

† These Electronically Commutated (EC) Motors are not available in 460V or 575V.

^ Dual-speed EC motors are compliant with California Title 24 regulations.

1. All fan motors are wired for single phase.

Hot Gas reverse cycle includes a fixed defrost termination control and a fixed fan delay control (factory wired) and a check valve between the hot gas drain pan circuit and the coil.

Use EC motors for 50 Hz operation.



Russell's All-Temp Low Profile Unit Cooler can be used in combination with R-Series Next-Gen MiniCon Condensing Units, providing complete refrigeration solutions for small to medium walk-ins

LOW PROFILE UNIT COOLER

Physical Data

MODELS		TXV* TYPE	REFRIGERANT CONNECTIONS				NO. OF HANGERS	DIMENSIONS (Inches)				APPROX. SHIP WT. (LBS)
AA	AE/AG^/AH^		All LIQUID†	AA SUCTION	AE/AG/AH SUCTION	HG		A	B	C	W	
18-41C	—	EXT	1/2 ODS	5/8 ODS	—	—	2	19	—	—	27	33
18-53C	—	EXT	1/2	5/8	—	—	2	19	—	—	27	34
18-66C	—	EXT	1/2	5/8	—	—	2	19	—	—	27	36
28-76C	—	EXT	1/2	5/8	—	—	2	33	—	—	41	48
28-97C	—	EXT	1/2	7/8	—	—	2	33	—	—	41	51
28-106C	—	EXT	1/2	7/8	—	—	2	37	—	—	45	58
28-122C	—	EXT	1/2	7/8	—	—	2	33	—	—	41	60
28-134C	—	EXT	1/2	7/8	—	—	2	37	—	—	45	63
38-160C	—	EXT	1/2	1-1/8	—	—	2	55	—	—	63	79
38-195C	—	EXT	1/2	1-1/8	—	—	2	55	—	—	63	84
48-212C	—	EXT	1/2	1-1/8	—	—	3	36-1/2	36-1/2	—	81	127
48-264C	—	EXT	1/2	1-1/8	—	—	3	36-1/2	36-1/2	—	81	151
58-275C	—	EXT	1/2	1-1/8	—	—	3	54-1/2	36-1/2	—	99	197
68-318C	—	EXT	1/2	1-1/8	—	—	4	37	36	36	117	243
68-390C	—	EXT	1/2	1-1/8	—	—	4	37	36	36	117	267
16-39C	16-36C^	EXT	1/2 ODS	5/8 ODS	5/8 ODS	5/8 ODS	2	19	—	—	27	41
16-48C	16-41C^	EXT	1/2	5/8	5/8	5/8	2	19	—	—	27	44
16-58C	16-46C^	EXT	1/2	5/8	5/8	5/8	2	19	—	—	27	47
26-70C	26-60C^	EXT	1/2	5/8	7/8	5/8	2	33	—	—	41	54
26-87C	26-75C^	EXT	1/2	7/8	7/8	5/8	2	33	—	—	41	55
26-115C	26-92C^	EXT	1/2	7/8	7/8	5/8	2	37	—	—	45	62
36-145C	36-120C^	EXT	1/2	7/8	7/8	5/8	2	55	—	—	63	78
36-170C	36-140C^	EXT	1/2	1-1/8	1-1/8	5/8	2	55	—	—	63	85
46-192C	46-164C^	EXT	1/2	1-1/8	1-1/8	5/8	3	36-1/2	36-1/2	—	81	124
46-230C	46-185C^	EXT	1/2	1-1/8	1-1/8	5/8	3	36-1/2	36-1/2	—	81	147
56-245C	56-210C^	EXT	1/2	1-1/8	1-1/8	5/8	3	54-1/2	36-1/2	—	99	195
66-295C	66-245C^	EXT	1/2	1-1/8	1-1/8	5/8	4	37	36	36	117	238
66-345C	66-280C^	EXT	1/2	1-1/8	1-1/8	5/8	4	37	36	36	117	262
14-42C	14-37C^	EXT	1/2 ODS	5/8 ODS	5/8 ODS	5/8 ODS	2	19	—	—	27	42
24-84C	24-72C^	EXT	1/2	7/8	7/8	5/8	2	37	—	—	45	49
24-105C	24-85C^	EXT	1/2	7/8	7/8	5/8	2	37	—	—	45	55
34-130C	34-105C^	EXT	1/2	7/8	7/8	5/8	2	55	—	—	63	79
44-170C	44-140C^	EXT	1/2	7/8	1-1/8	5/8	3	36-1/2	36-1/2	—	81	144
54-215C	54-180C^	EXT	1/2	1-1/8	1-1/8	5/8	3	54-1/2	36-1/2	—	99	191
64-255C	64-215C^	EXT	1/2	1-1/8	1-1/8	5/8	4	37	36	36	117	257

^ Hot Gas Defrost models (AG, AH) are not available in Revision Code "C" configuration and must be designated as Revision Code "B".

† Sweat Gas connection at the distributor. Mounted TXV outlet size may vary. All factory mounted Liquid Line Solenoids have 3/8" outlets.

* External equalized.

Installation Notes:

- (1) Install 12" away from back wall.
- (2) Drain connection on AA and AE units are centered on drain pan; and on the left rear corner (facing air discharge) on AG and AH models.
- (3) For long air throw requirements, specify high throw fan guard.
- (4) Unit height at drain end of hot gas models is as follows: 1,2, and 3 fan models = 15-7/8"; 4,5, and 6 fan models = 16-1/4".

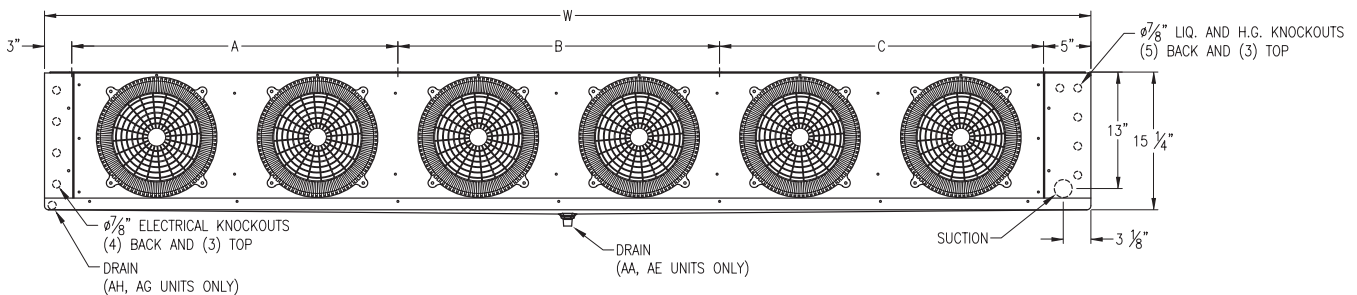
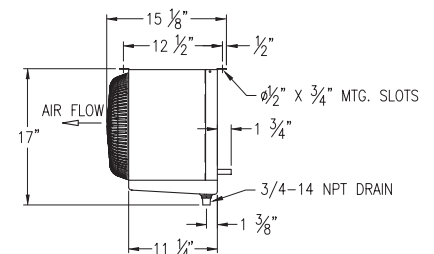

ALL-TEMP

Electric Defrost Kits

MODEL NUMBER	1 UNIT COOLER PER SYSTEM		2 UNIT COOLERS PER SYSTEM		3 UNIT COOLERS PER SYSTEM	
	230V	460V	230V	460V	230V	460V
AE16-36C	ED-5	ED-17	ED-20*	ED-22	ED-30	ED-32
AE16-41C	ED-5	ED-17	ED-20*	ED-22	ED-30	ED-32
AE16-46C	ED-5	ED-17	ED-20*	ED-22	ED-30	ED-32
AE26-60C	ED-5	ED-17	ED-20*	ED-22	ED-30	ED-32
AE26-75C	ED-5	ED-17	ED-20*	ED-22	ED-30	ED-32
AE26-92C	ED-5	ED-17	ED-20*	ED-22	ED-30	ED-32
AE36-120C	ED-5	ED-17	ED-20*	ED-22	ED-33	ED-32
AE36-140C	ED-5	ED-17	ED-20*	ED-22	ED-33	ED-32
AE46-164C	ED-6	ED-17	ED-23*	ED-22	ED-35	ED-32
AE46-185C	ED-6	ED-17	ED-23*	ED-22	ED-35	ED-32
AE56-210C	ED-7	ED-17	ED-23*	ED-22	ED-35	ED-34
AE66-245C	ED-7	ED-17	ED-23*	ED-22	ED-35	ED-34
AE66-280C	ED-7	ED-17	ED-23*	ED-22	ED-35	ED-34
AE14-37C	ED-5	ED-17	ED-20*	ED-22	ED-30	ED-32
AE24-72C	ED-5	ED-17	ED-20*	ED-22	ED-30	ED-32
AE24-85C	ED-5	ED-17	ED-20*	ED-22	ED-30	ED-32
AE34-105C	ED-5	ED-17	ED-20*	ED-22	ED-33	ED-32
AE44-140C	ED-6	ED-17	ED-23*	ED-22	ED-35	ED-32
AE54-180C	ED-7	ED-17	ED-23*	ED-22	ED-35	ED-34
AE64-215C	ED-7	ED-17	ED-23*	ED-22	ED-35	ED-34

KIT NO.	TIMER	AUXILIARY SWITCH	BLOCK-OUT RELAY	DEFROST CONTACTOR	FAN CONTACTOR	SEQUENCING RELAY
ED5-230/1	1	—	1-15A	—	—	—
ED5-230/3	1	—	1-15A	—	—	—
ED6-230/1	1	—	1-20A	—	—	—
ED6-230/3	1	—	1-20A	—	—	—
ED7-230/1	1	—	1-25A	—	—	—
ED7-230/3	1	—	1-25A	—	—	—
ED10-230/1	1	—	1-30A	—	—	—
ED11-230/3	1	1	—	1-30A	—	—
ED17-460/3	1	1	—	1-15A	1-15A	—
ED18-460/3	1	1	—	1-20A	1-20A	—
ED12-460/3	1	1	—	1-30A	1-25A	—
¹ ED210-230/1	1	—	1-30A	—	—	—
¹ ED213-230/1	1	1	—	1-50A	—	—
¹ ED213-230/3	1	1	—	1-50A	—	—
ED20-230/1	1	—	1-30A	—	—	2
ED22-460/3	1	1	—	2-15A	1-25A	2
ED23-230/1	1	1	—	2-25A	—	2
ED23-230/3	1	1	—	2-25A	—	2
ED30-230/1	1	—	1-30A	—	—	3
ED32-460/3	1	1	—	3-10A	1-25A	3
ED33-230/1	1	1	—	3-16A	—	3
ED34-460/3	1	1	—	3-16A	1-25A	3
ED35-230/1	1	1	—	3-33A	—	3
ED35-230/3	1	1	—	3-33A	—	3

¹ For use with 2 evaporators, 1/2 through 3 HP R-series systems ONLY!

Electric defrost kits consist of components that are necessary to control the defrost cycle. The kits are available as a factory installed option when ordered with a condensing unit. Not all Ed-Kits are available for all condensing unit models. The contents of each kit is described below, along with the function of each component.

* - 1/2 through 3 HP condensing units require ED-210 or ED-213 for systems with 2 evaporators.

Timer: Initiates the defrost cycle. Also used as a override protection for defrost termination.

Auxiliary Switch: It's mounted on the compressor contactor and prevents the defrost contactor from operating whenever the compressor is energized.

Block-Out Relay: Serves the same function as auxiliary switch. Used when defrost contactor is not required (lower wattage single phase only).

Defrost Contactor: Carries amperage load for heaters.

Fan Contactor: Used with 460V motors or when 230V motors are wired 3 phase.

Sequencing Relays: Provides interconnection of multiple unit coolers on a single system so that each unit cooler is allowed to individually terminate defrost on temperature.

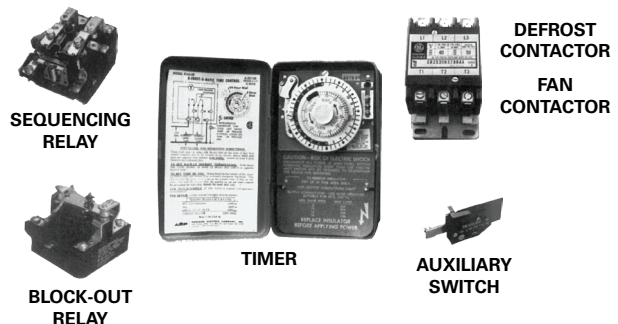

Due to continuing product development, specifications are subject to change without notice.

